

K.C. DuBois,

Wardrobe Bedstead.

No. 102098.

Patented Apr. 19, 1870.

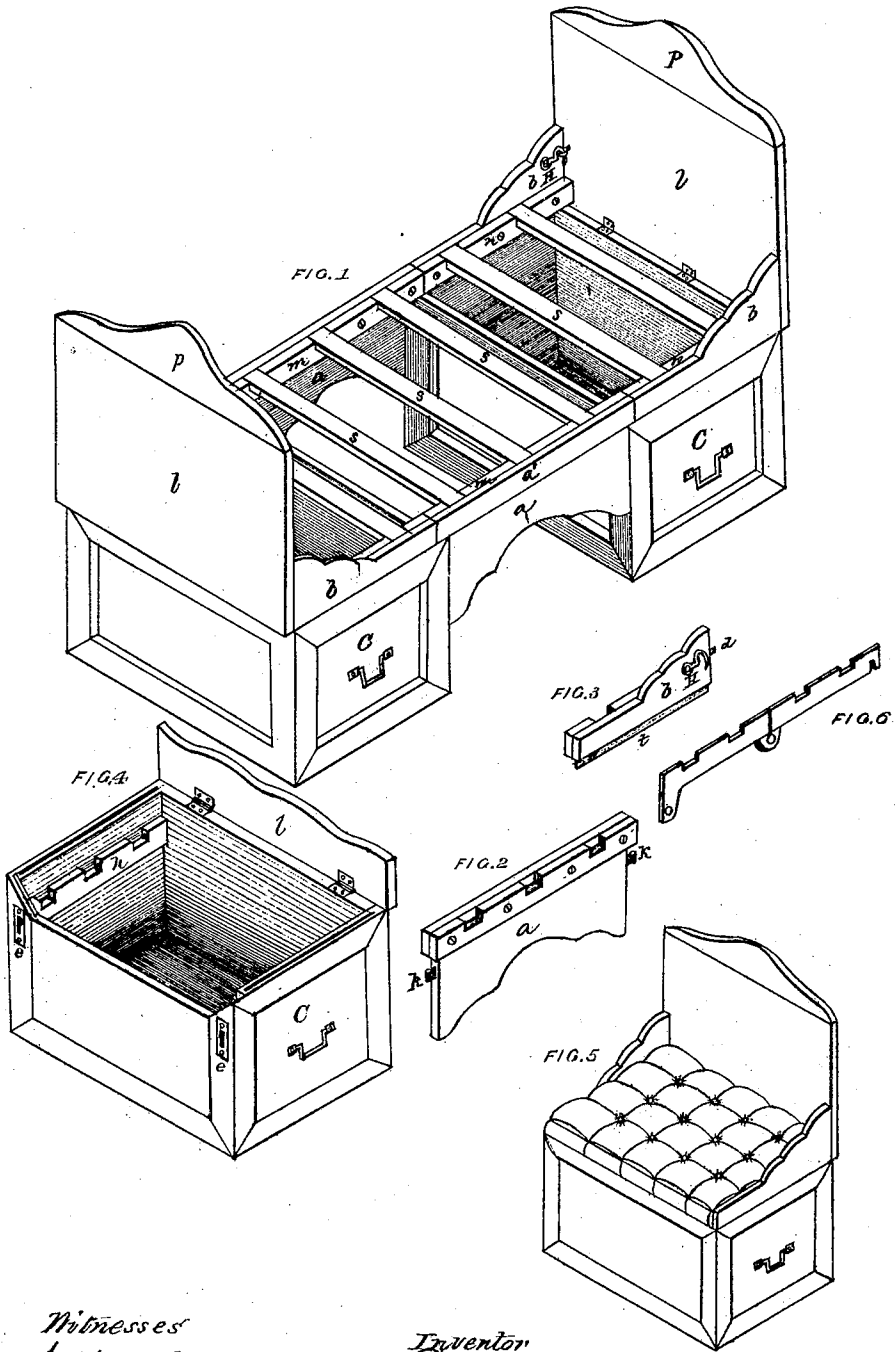

Witnesses
K. DuBois
Chas. L. DuBois

Inventor
Richard C. DuBois

United States Patent Office.

RICHARD C. DU BOIS, OF WASHINGTON, DISTRICT OF COLUMBIA.

Letters Patent No. 102,098, dated April 19, 1870.

IMPROVED FRENCH BEDSTEAD.

The Schedule referred to in these Letters Patent and making part of the same.

I, RICHARD C. DU BOIS, of Washington City, in the District of Columbia, have invented an Improved Portable Bedstead, of which the following is a specification.

Nature and Objects of the Invention.

This invention has for its object to provide a cheap portable bedstead, single or double, by connecting together two trunks, camp-chests, or packing-chests, by simple devices which may readily be taken apart and put together, and which may all be packed away in one of the trunks or chests without occupying much room. The trunks or chests, separately or together, may also be converted readily into sofas or divans, which will constitute useful and tasteful articles of furniture.

Description of the Accompanying Drawings.

Figure 1 is an isometrical perspective view of the bedstead, as arranged for the mattresses;

Figure 2, a view of one of the connecting-arches or rails;

Figure 3, a view of one of the brackets or braces which support the lids when raised to a vertical position, to form the foot-board and head-board;

Figure 4, an isometrical view of one of the chests, with a part of the lid, showing a part of the front side removed, so that the slats may be let down into the chest, if desired;

Figure 5, one of the chests arranged for a divan or sofa; and

Figure 6, a hinged bar, which may be used instead of the connecting-arches.

General Description.

C C are the trunks or chests, with their lids *u* raised to a vertical position and held in place by the braces or brackets-*b b*.

The lids, when so raised, may be capped with ornamental pieces, *p p*, attached by dowels, or otherwise.

a a are the connecting-rails, made, preferably, in an arched form, and provided with the projections *k k*, which fit into corresponding recesses in the plates *e e*, placed in the front side of the chests. These fastenings may be of the kind ordinarily used in bedsteads.

The top-piece *a'* of the arch or rail projects slightly at each end, so as to rest upon the edge of the chest. The length of these connecting-arches *a a* will be

varied according to the width of the chests and the desired length of the bedstead.

The arches *a a* and braces *b b* are provided with the cleats *m m* and *n n*, notched to receive the cross-slats *s s*.

The lower edge of the brace *b* is tongued, *t*, to fit into the groove made in the edge of the chest, and also provided with the hook *H*, to hold up the lids *l l*.

Fig. 4 shows the manner of lowering the slats so that the mattress may come below the outer edges of the chests. The cleat *h*, for holding the slats, is attached to the inside of the chest, at such a height as to bring the slats a little higher than the front edge of the chest, so as to allow for the spring of the slats when pressed down by the weight of the mattress and the person resting upon it.

The mattress is made in sections, each section of a size to fit into the chest when packed away. One of these sections will form the cushion for the divan, as shown in fig. 5.

If the chests are neatly and tastefully constructed, and the cushions properly covered, they will, when used in this manner, form attractive articles of furniture, and at the same time be useful for packing purposes.

All the extra parts may be made of such a size and form as to be packed away in one of the chests with the mattresses, pillows, blankets, and a year's supply of bed-linen, and at the same time leave room for packing other articles of clothing, pictures, looking-glasses, &c. The whole of the other chest will be left for packing purposes.

Instead of the connecting-arches *a a*, adjustable jointed bars, similar to the one shown in fig. 6, are to be attached to the inside of one of the chests, and folded inside when not in use. This form might be better adapted to traveling-trunks or chests than the arched connection.

Claim.

I claim as my invention—

The combination and arrangement of the trunks or chests C C, arches *a a*, braces *b b*, and cross-slats *s s*, substantially as set forth.

RICHARD C. DU BOIS.

Witnesses:

N. DU BOIS,
CHAS. L. DU BOIS.