

(No Model.)

3 Sheets—Sheet 1.

W. WATTIE.
LOOM.

No. 544,703.

Patented Aug. 20, 1895.

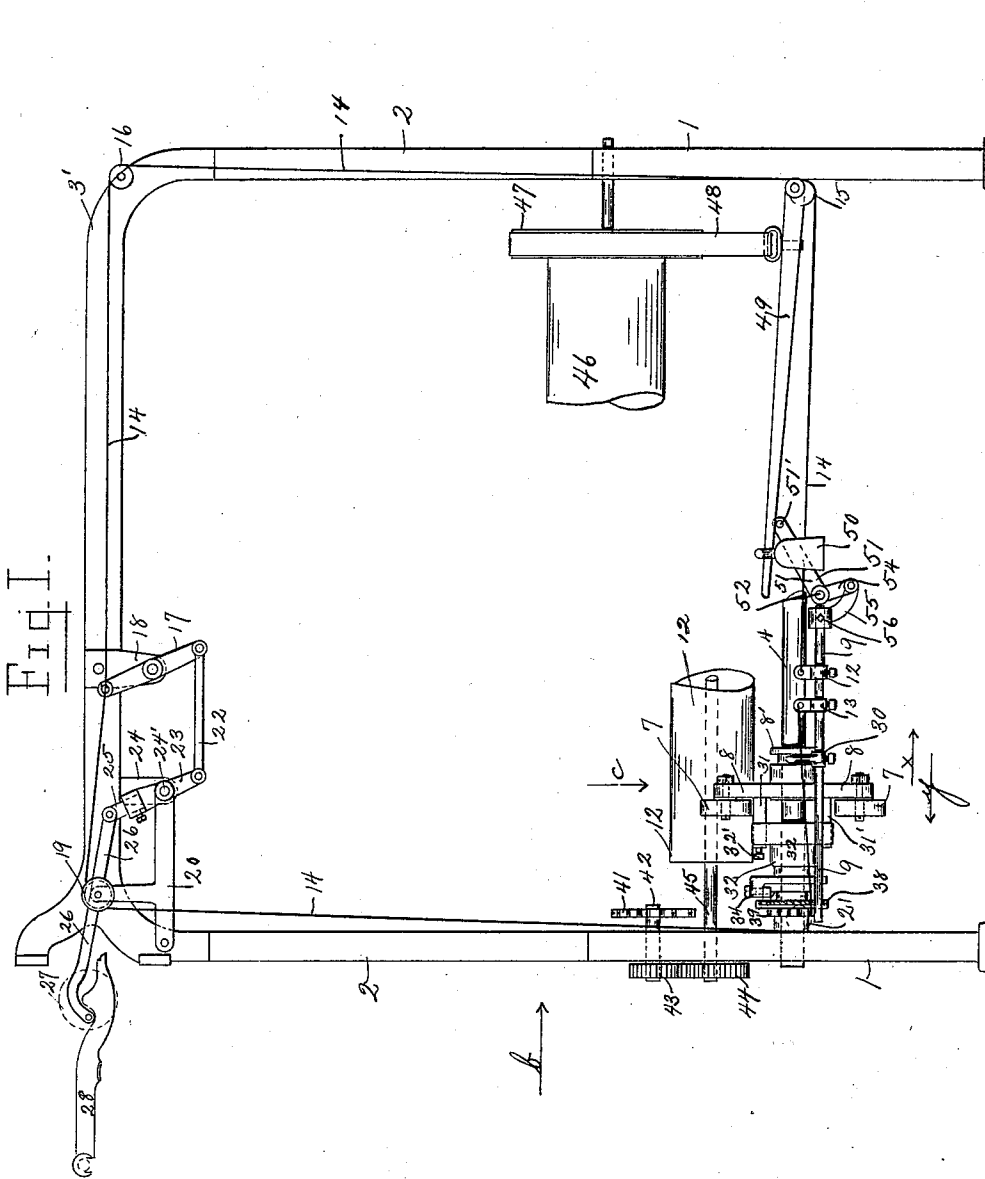

Witnesses
 Irving H. Henry
 Jesse H. Henry

Inventor
 William Wattie.
 By his Attorneys
 John C. Dewey.

(No Model.)

3 Sheets—Sheet 2.

W. WATTIE.
LOOM.

No. 544,703.

Patented Aug. 20, 1895.

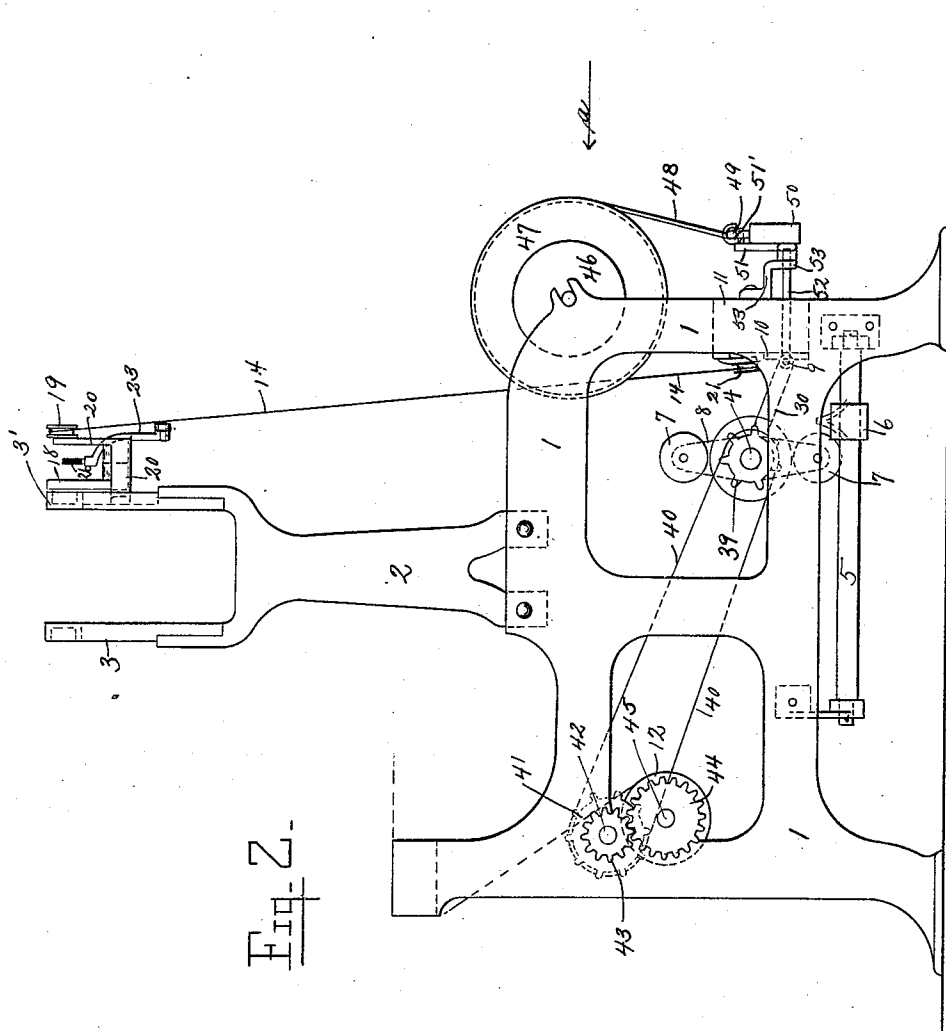

Fig. 2.

Witnesses

Irving H. Kerry
James H. Kerry

Inventor

William Wattie

By his Attorney

John C. Dewey

(No Model.)

3 Sheets—Sheet 3.

W. WATTIE.
LOOM.

No. 544,703.

Patented Aug. 20, 1895.

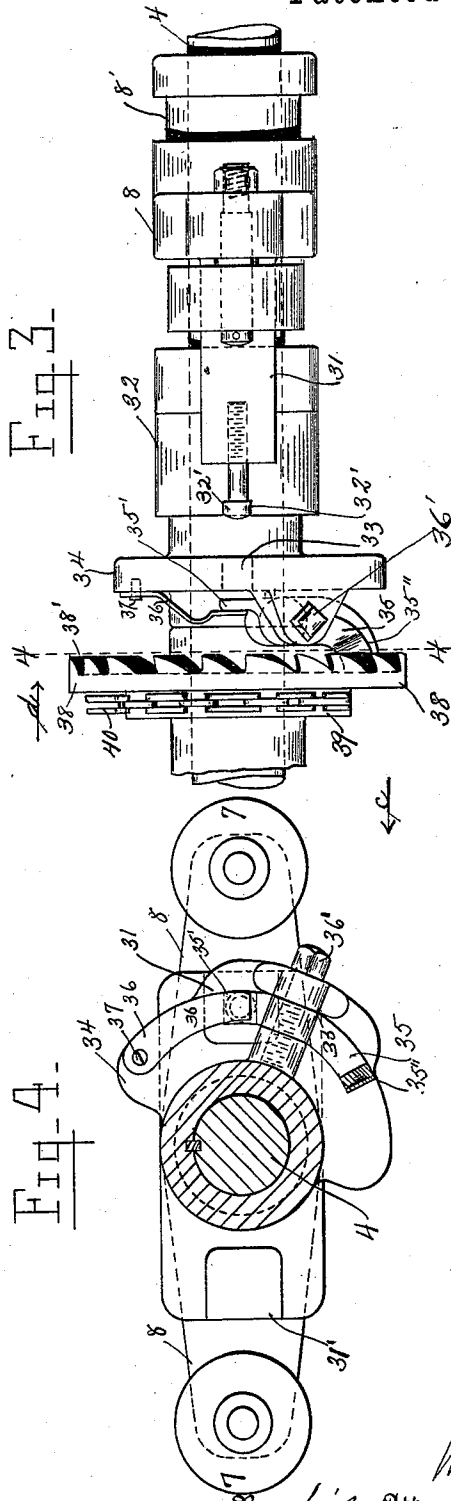

Witnesses

Irving H. Verry.
Frederic W. Verry.

Inventor

William Wattie.

By his Attorney

John C. Derwey.

UNITED STATES PATENT OFFICE.

WILLIAM WATTIE, OF WORCESTER, MASSACHUSETTS, ASSIGNOR TO THE
KNOWLES LOOM WORKS, OF SAME PLACE.

LOOM.

SPECIFICATION forming part of Letters Patent No. 544,703, dated August 20, 1895.

Application filed March 14, 1895. Serial No. 541,700. (No model.)

To all whom it may concern.

Be it known that I, WILLIAM WATTIE, a citizen of the United States, residing at Worcester, in the county of Worcester and State of Massachusetts, have invented certain new and useful Improvements in Looms, of which the following is a specification.

My invention relates to looms. In weaving fabrics with a fringe, such as towels, &c., in order to save time when the fringe is to be added to the fabric it is necessary that the fabric should be wound faster on the take-up roll than it is at the time the body of the fabric is woven. It will be understood that in the ordinary running of a loom the take-up roll is rotated at a regular speed by means of suitable take-up mechanism, as a ratchet-and-pawl mechanism, operated from some driven part of the loom. (See United States Letters Patent No. 437,894, of October 7, 1890.) In order to wind the fabric faster upon the take-up roll at certain intervals, it is necessary to provide supplemental mechanism for operating the take-up roll faster, and the object of my present invention is to provide supplemental mechanism which may be attached to and combined with any loom and with any take-up mechanism, to operate the take-up roll faster at certain intervals, as when the fringe is being added to the fabric.

My invention consists in certain novel features of construction and operation of my supplemental take-up mechanism to automatically communicate a faster motion at certain times to the take-up roll from the bottom shaft or other driven part of the loom independently of the ordinary take-up mechanism.

In carrying out my invention I combine, preferably with the bottom shaft of the loom, any well-known clutch mechanism one member of which is fast on the shaft and the other member loose, and cause the clutch members to be automatically moved into or out of clutch at predetermined intervals through connections to the pattern-indicating mechanism. The clutch mechanism is connected by a sprocket-chain, sprocket-wheels, and a system of gears with the shaft of the take-up roll, so as to operate the take-up roll faster from the bottom shaft independently of the

ordinary take up mechanism. It is desirable that the picking of the shuttles should stop during the operation of my supplemental take-up mechanism and while the fringe is being added to the fabric, and I prefer to use my mechanism on a loom provided with mechanism for controlling the action of the fly-shuttle mechanism, but it may be used on looms without said mechanism.

I have shown in the drawings my supplemental take-up mechanism, combined with mechanism for controlling the action of the fly-shuttle mechanism of the construction and operation fully set out in United States Letters Patent No. 474,170, of May 3, 1892, to which reference is made. I have not shown in the drawings the parts of a loom which are not connected with my mechanism, for the sake of clearness.

Referring to the drawings, Figure 1 is a rear elevation of a loom-frame, showing my mechanism combined with the sliding-pick mechanism above referred to, looking in the direction of arrow *a*, Fig. 2. Fig. 2 is an end view looking in the direction of arrow *b*, Fig. 1. Fig. 3 is a plan detail of a portion of the sliding-pick mechanism and my clutch mechanism, looking in the direction of arrow *c*, Figs. 1 and 4; and Fig. 4 is a cross-section on line 4 4, Fig. 3, looking in the direction of arrow *d*, same figure. Figs. 3 and 4 are shown on an enlarged scale.

In the accompanying drawings, 1 represents the loom sides; 2, the arch-stands; 3, the front arch, and 3' the back arch.

4 is the bottom shaft; 5, the picking-shaft, which extends at right angles to the bottom shaft 4 and carries the picking-shoe 6, (shown in Fig. 2,) operated on by the rolls 7 carried on the arm or casting 8, adapted to slide on and rotate with the bottom shaft 4. The mechanism for sliding the casting 8 on the bottom shaft 4 to move the rolls 7 into or out of engagement with the picking-shoe 6 consists of the sliding rod 9, supported in bearings 10 on the back girt 11. (See Fig. 2.)

Fast upon the sliding rod 9 are collars 12 and 13. To one collar, as 12, is attached one end of a cord 14 which passes over a pulley 15 at the lower part of the loom-frame and over a second pulley 16 on the back arch 3'

and is attached to the upper end of a lever 17, pivoted on a bracket 18 on the back arch 3'. From said lever 17 the cord 14 passes over a pulley 19 on a stand 20, bolted to the back arch 3' and over a pulley 21 at the lower part of the loom-frame to the collar 13 on the sliding rod 9, to which collar the other end of the cord 14 is attached.

The lever 17, through connection 22, is attached to the lever 23 pivoted at 24' on a stand 24 secured on the back arch 3'. The lever 23 is provided with an adjustable arm 25 attached to one end of the connector 26, pivoted on the vibrator-gear 27. (Shown by broken lines, Fig. 1.) The vibrator-gear 27 is mounted on the vibrator-lever 28 of the head motion in the usual way. It will thus be seen that an endwise or longitudinal motion will be communicated to the rod 9 by the movement of the lever 17 through the cord 14 in one direction or the other, according to the indications of the pattern-chain (not shown) on the vibrator 28, which operates through vibrator-gear 27, connector 26, lever 23, and connection 22 the lever 17. The sliding rod 9 carries a forked arm 30, secured at one end on said rod 9, with its forked end adapted to engage with the grooved hub 8' of the arm or casting 8 which carries the picking-rolls 7. The casting 8 is keyed onto the bottom shaft 4 to revolve with said shaft, and also slide thereon, and is provided with projecting pins 31 and 31', which slide freely in corresponding channels in the hub 32 fast on the bottom shaft 4.

I will now describe my supplemental take-up mechanism for operating the take-up roll faster at certain intervals. As above stated I have shown in this instance my mechanism combined with the mechanism for regulating the action of the fly-shuttle mechanism set out in said Patent No. 474,170, and the operation of said mechanism automatically operates my clutch mechanism to throw the same into clutch, to rotate the take-up roll faster, or out of clutch, to allow the take-up roll to rotate at the regular speed, as desired.

I have shown a clutch mechanism on the bottom shaft in the form of a ratchet and pawl, the ratchet being loose on the shaft and connected with the take-up roll through intervening mechanism, and the pawl being supported on a flange fast on the bottom shaft, and being moved into or out of engagement with the ratchet by the sliding motion of the arm or casting 8 of the picking mechanism.

The pawl-flange 34 is fast on the bottom shaft 4 and carries a pawl 35 pivoted on a bolt 36', which is secured on said pawl-flange 34 on the bottom shaft 4. A spring 36, secured at one end by a screw 37 to the pawl-flange 34, acts at its free end on the heel 35' of the pawl 35, and operates to move out the opposite end 35'' of the pawl 35 when a set-screw 32', tapped into the end of the pin 31 projecting from the casting 8 and adapted to

pass through a hole 33 in the pawl-flange 34, is moved away from the heel 35' of said pawl by the sliding of said casting 8 on the bottom shaft 4, as shown in Figs. 1 and 3. A ratchet-plate 38 is mounted loose on the bottom shaft 4, and has ratchet-teeth 38' thereon toward the pawl 35, adapted to be engaged by said pawl. The ratchet-plate 38 is provided with a sprocket-wheel 39, around which passes a sprocket-chain 40. Said sprocket-chain 40 also passes around a sprocket-wheel 41 fast on a shaft 42, mounted in bearings on the loom-frame over the take-up roll 12, at the front of the loom. On the other end of said shaft 42 is fast a pinion 43, which meshes with the take-up-roll gear 44, fast on the take-up-roll shaft 45. (See Figs. 1 and 2.)

The warp-beam 46 is supported at the rear of the loom in the usual way, and is provided with a friction beam-head 47, around which passes the friction-strap 48, which is attached at one end to the lever 49, pivoted at one end and carrying at its free end a weight 50 in the usual way.

In order to operate the friction-lever 49 automatically to reduce the friction of the strap 48 on the beam-head 47 and allow the warp-beam 46 to revolve freely to let off the warp when the fringe is being added to the fabric, I provide means for raising the lever 49 through an arm 51, fast on a rock-shaft 52 and carrying a pin 51', which extends under said lever.

The rock-shaft 52 is supported at its outer end in the lower end of a bracket 53 bolted to the back girt of the loom, (see Fig. 2,) and carries at its inner end an arm 54 fast thereon, which is connected by a curved arm 55 with the sliding rod 9. The inner end of said arm 55 is adjustably attached to the sliding rod 9 by a set-screw 56. (See Fig. 1.) It will thus be seen that as the sliding rod 9 is moved in the direction of arrow *x*, Fig. 1, to move the picking-rolls 7 out of engagement with the picking-shoe 6 to stop the picking motion while the fringe is being added to the fabric the lever 49 will be raised through the arm 55, arm 54, rock-shaft 52, and arm 51, carrying pin 51', to release the friction-strap 48 and allow the warp-beam 46 to revolve freely.

From the above description, in connection with the drawings, the operation of my take-up mechanism for communicating a faster motion to the take-up roll while the fringe is being added to the fabric and the filling mechanism has stopped by the operation of the sliding pick mechanism will be readily understood by those skilled in the art.

Fig. 1 shows my mechanism in the position it occupies when the fringe is being added to the fabric. After the fringe has been added and the body of the fabric is to be woven, the operation is as follows: The movement of the pattern-chain (not shown) will bring a tube under the indicator-lever 28 and cause the vibrator-gear 27 to drop into contact with the bottom cylinder-gear. (Not shown.) The revolu-

tion of said gear will cause said vibrator-gear 27 to revolve in the usual manner, and to operate the connector 26, and through said lever and the lever 23 and connection 22 operate the lever 17, to which is attached the cord 14, and through said cord, attached at its ends to the collars 12 and 13 on the sliding rod 9, move said sliding rod 9 endwise in the direction of arrow *x*, Fig. 1, and through the forked arm 30, fast on said rod 9 and engaging the grooved hub 8' of the casting 8, move said casting 8 and carry the picking-rolls 7 thereon into engagement with the picking-shoe 6. At the same time the head of the set-screw 32' will enter the hole 33 in the pawl-flange 34 and engage the heel of the pawl 35, and move said pawl, against the action of the spring 36, out of engagement with the ratchet-teeth 38' on the ratchet-plate 38, allowing said plate 38 to run loose on the bottom shaft 4, so as not to operate the take-up roll. At the same time the endwise movement of the sliding rod 9, through curved arm 55, arm 54, rock-shaft 52, and arm 51, carrying the pin 51', which engages the lever 49, will allow said lever 49 to move down to tighten the friction-strap 48 on the beam-head 47 and apply the friction to the warp-beam 46.

After the body of the fabric has been woven, the pattern-chain is moved, and through a roll, the indicator-lever, vibrator-gear, and connector 26 are operated to cause, through the intervening mechanism, sliding rod 9 to move in the opposite direction, (indicated by arrow *y*, Fig. 1,) to disengage the picking-rolls and cause the set-screw 32' to move away from the heel 35' of the pawl 35 and allow the spring 36 to act to cause said pawl 35 to engage with the ratchet-teeth 38' on the ratchet-plate 38, and cause said plate to revolve with the pawl-plate 34, fast on the bottom shaft 4, and through sprocket-wheel 39, sprocket-chain 40, sprocket-wheel 41, pinion 43, and gear 44 operate the take-up roll 42.

The advantages of my mechanism for operating the take-up roll faster when the fringe is being added to the fabric will be readily appreciated by those skilled in the art. It is of simple construction and operation and adapted to be applied to looms of ordinary construction, and combined with any sliding-pick mechanism, and operated thereby to automati-

cally communicate a faster motion to the take-up roll when desired, or operated independently of the sliding-pick mechanism, through connections to the pattern-indicating mechanism.

It will be understood that the details of construction of some of the parts of my mechanism may be varied somewhat if desired, and any form of clutch mechanism may be used, and the same be combined with a sliding-pick mechanism, or used without said mechanism.

Having thus described my invention, what I claim as new, and desire to secure by Letters Patent, is—

1. In a loom adapted to weave towels, &c., a supplemental automatic take-up mechanism for operating the take-up roll faster when the fringe is added to the fabric, said mechanism consisting of a clutch mechanism on a driven shaft of the loom, and said shaft, and a sprocket chain and wheel mechanism connecting said clutch mechanism with a system of gears for driving the shaft of the take-up roll, and said take-up roll, and connections, intermediate the pattern indicating mechanism and the clutch mechanism, to automatically operate the clutch mechanism and cause the take-up roll to rotate faster, when desired, substantially as set forth.

2. In a loom adapted to weave towels, &c., a supplemental automatic take-up mechanism for operating the take-up roll faster when the fringe is added to the fabric, said mechanism consisting of a clutch mechanism on a driven shaft of the loom, and said shaft, a sprocket chain and wheel mechanism connecting said clutch mechanism with a system of gears connected with the shaft of the take-up roll, and said take-up roll, and a sliding pick mechanism for controlling the operation of the clutch mechanism, and connections intermediate the pattern indicating mechanism and said sliding pick mechanism to automatically operate said sliding pick mechanism and clutch mechanism, to stop the picking of the shuttles, and cause the take-up roll to rotate faster, when desired, substantially as set forth.

WILLIAM WATTIE.

Witnesses:

JOHN C. DEWEY,
M. J. GALVIN.