

Jan. 6, 1925.

1,522,010

G. G. GOING

TYPEWRITING MACHINE

Filed April 9, 1921

3 Sheets-Sheet 1

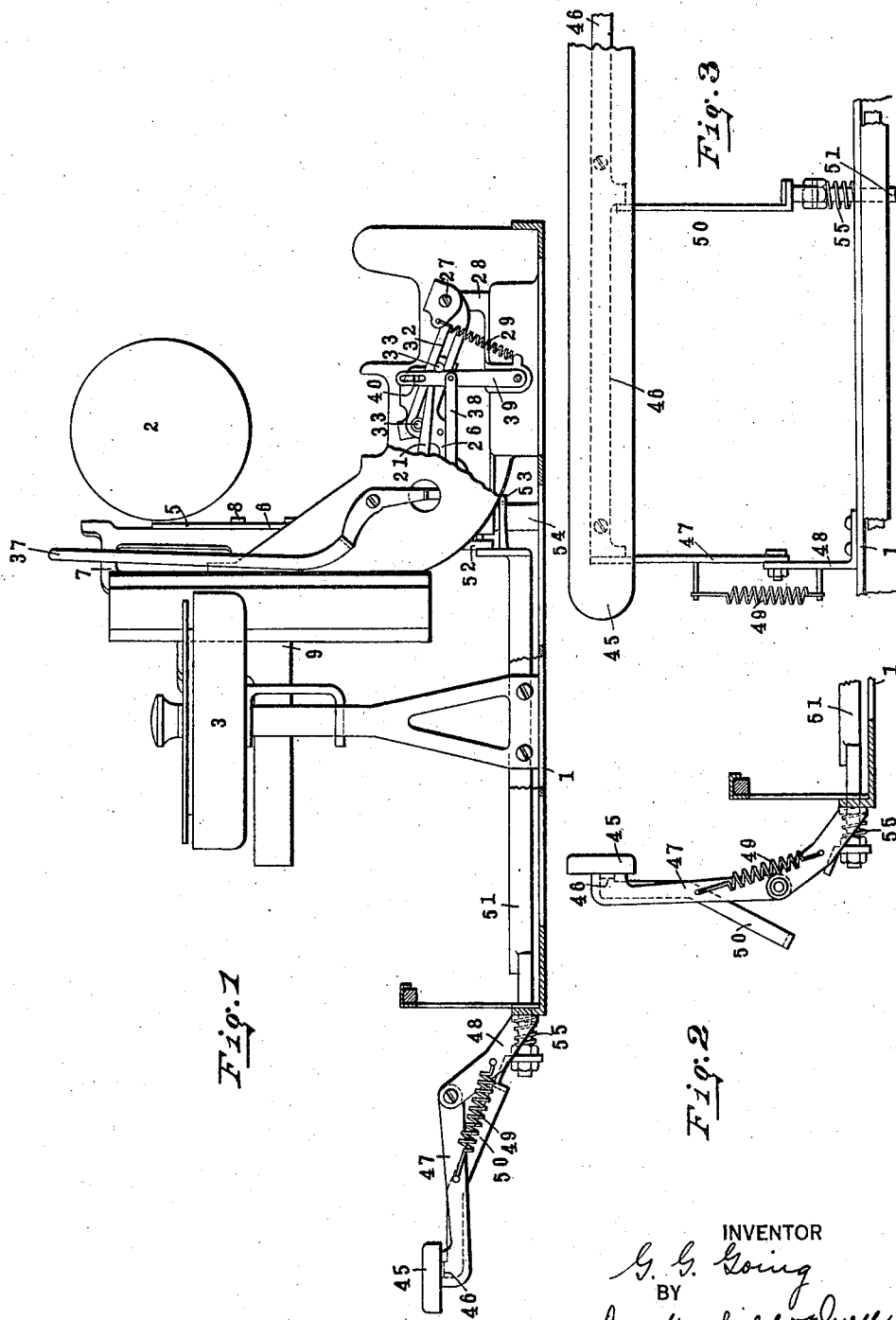

INVENTOR
G. G. Going
BY
Shel. Warfield & Co.
ATTORNEY

Jan. 6, 1925.

1,522,010

G. G. GOING

TYPEWRITING MACHINE

Filed April 9, 1921

3 Sheets-Sheet 2

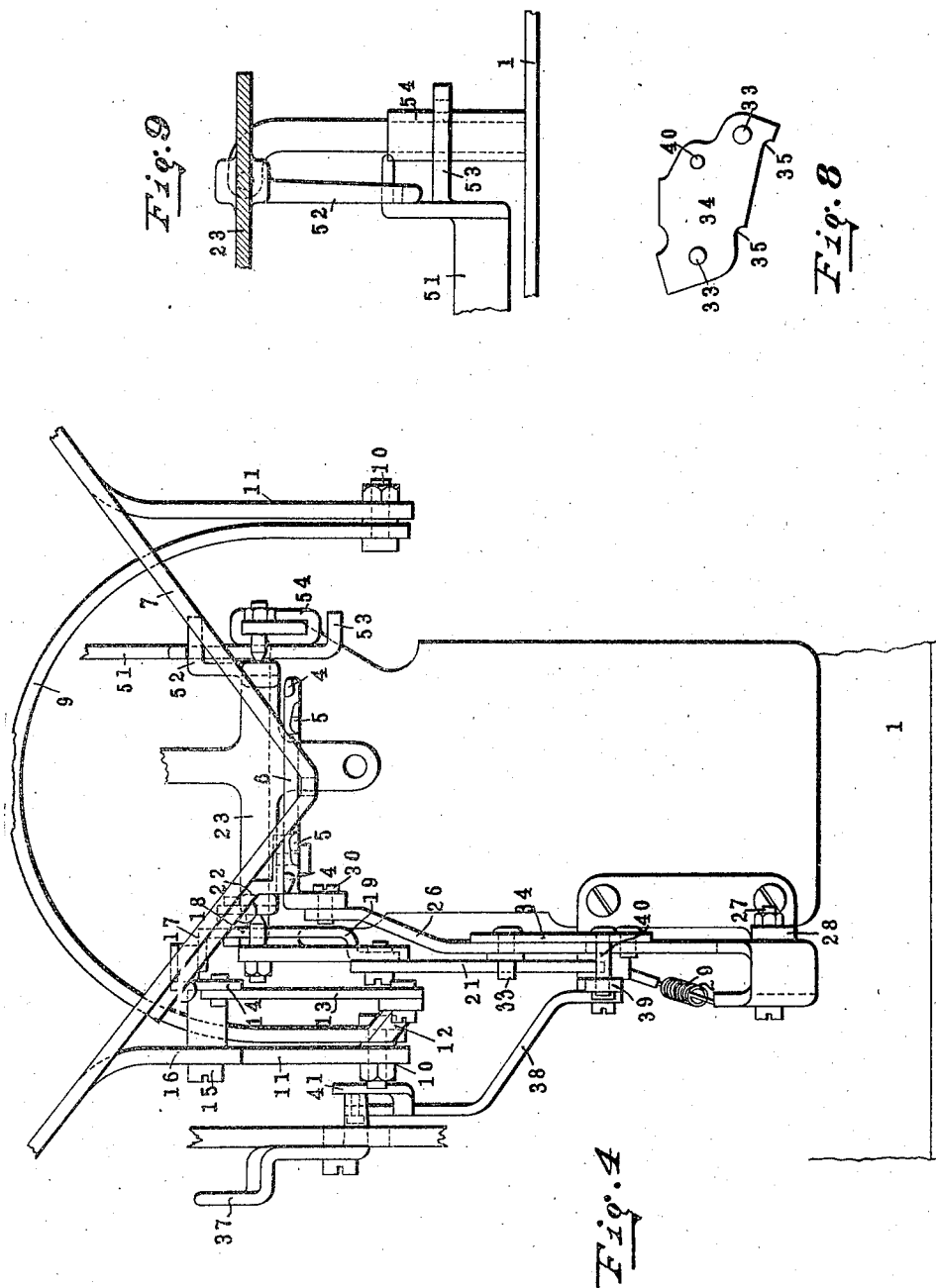

INVENTOR
G. G. Going
BY
Duell, Warfield & Duell
ATTORNEY

Jan. 6, 1925.

1,522,010

G. G. GOING

TYPEWRITING MACHINE

Filed April 9, 1921

3 Sheets-Sheet 3

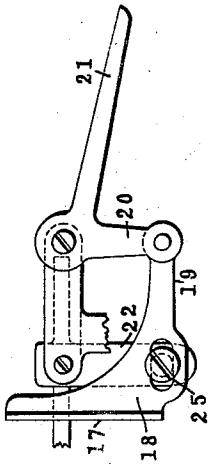

Fig. 7

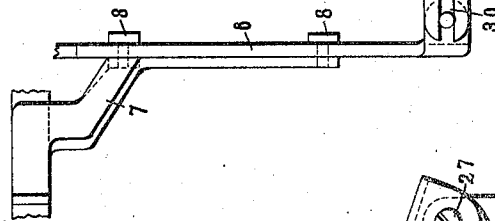

Fig. 6

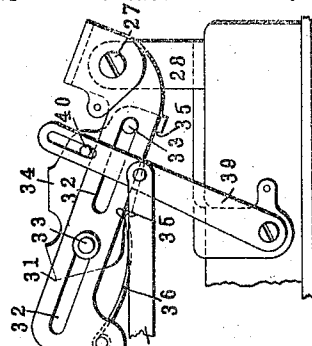
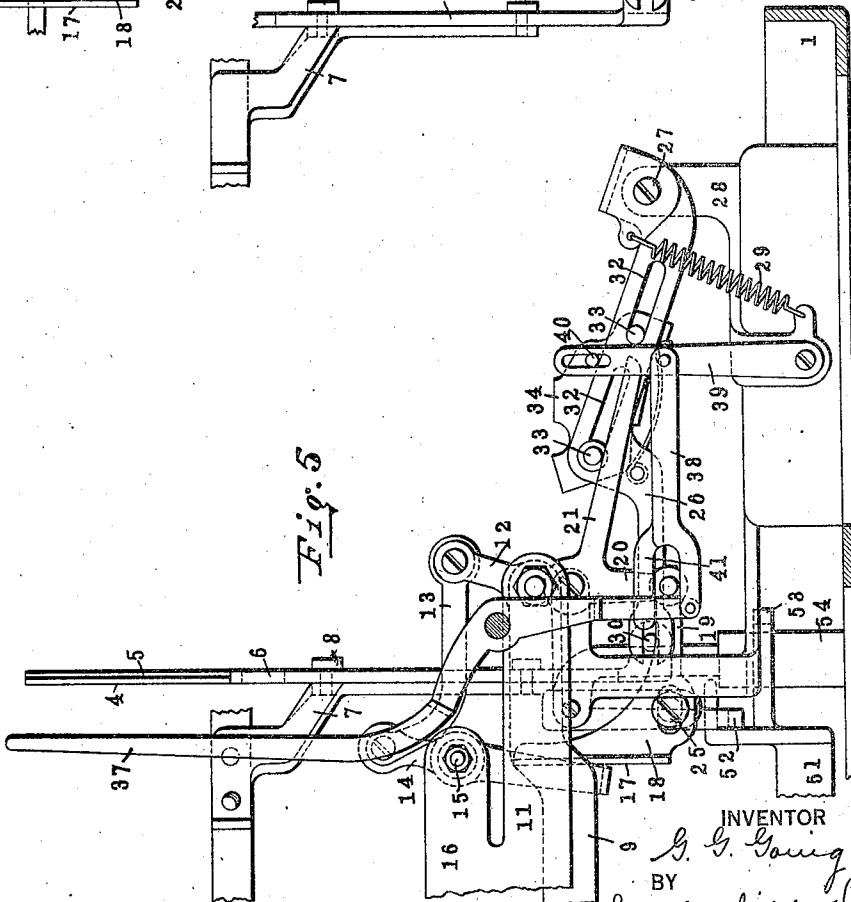

Fig. 5



INVENTOR

G. G. Going

BY

Duell Warfield Duell

ATTORNEY

UNITED STATES PATENT OFFICE.

GEORGE GOULD GOING, OF MIDDLETOWN, CONNECTICUT, ASSIGNOR, BY MESNE ASSIGNMENTS, TO REMINGTON-NOISELESS TYPEWRITER CORPORATION, A CORPORATION OF NEW YORK.

TYPEWRITING MACHINE.

Application filed April 9, 1921. Serial No. 459,920.

To all whom it may concern:

Be it known that I, GEORGE GOULD GOING, a citizen of the United States, residing at Middletown, in the county of Middlesex and State of Connecticut, have invented certain new and useful Improvements in Typewriting Machines, of which the following is a full, clear, and exact description, such as will enable others skilled in the art to which it appertains to make and use the same.

This invention relates to writing machines and in some of its details more particularly to vibrating mechanism for ribbons employed for supplying ink in connection with typewriting machines.

It is an object of the invention to provide an improved mechanism of the class mentioned of simple and sturdy construction, arranged to vibrate the inking ribbon as the type key is depressed bringing the ribbon into position to be struck by the type characters when advanced to impart an impression on the paper.

It is a further object to provide a ribbon vibrating mechanism of the class mentioned with improved means to vary the amplitude of vibration so as to bring differently colored portions thereof into alignment with the type bar characters.

Other objects will be in part obvious from the following detailed description of the invention and in part pointed out in connection therewith.

In the accompanying drawings wherein an illustrative but preferred embodiment of the invention is shown,

Figure 1 is a fragmentary sectional elevation of a typewriting machine equipped with the invention, certain of the parts being removed for clearness of disclosure;

Fig. 2 is a fragmentary sectional elevation showing the spacer bar mechanism;

Fig. 3 is a plan view thereof;

Fig. 4 is an enlarged fragmentary plan of the ribbon vibrating mechanism;

Fig. 5 is a side elevation thereof looking toward the left of Fig. 4;

Figs. 6, 7 and 8 are detail views of the ribbon vibrating mechanism, and

Fig. 9 is a detail view of the spacing mechanism.

Referring to the drawings, a typewriting machine is shown having a base plate 1 forming a part of the frame of the machine

to which the various operating elements are attached. The platen 2 is carried by the frame in any desired manner in a position to be engaged by the type bars (not shown) as the latter are moved rearwardly upon depression of the key levers. Ribbon spools are provided at opposite sides of the machine, one being shown at 3, the inking ribbon being wound thereon and extending therebetween in position to be engaged by the type characters as the latter are pressed against the paper to impart an impression of the character in a manner well known in the art.

The reach of ribbon between spools 3 passes between furcations 4 and 5 of a bifurcated ribbon support or vibrator 6 mounted for vertical reciprocation on the type bar guide plate 7 as by means of lug 8 passing through slots in the support. This support is actuated by operation of the writing machine, as for example, when a type key is depressed, to raise the ribbon into the path of movement of the advancing type bar, and the support is lowered as the type bar recedes. This lowering of the ribbon permits a full view of the writing being done. It is sometimes desirable to raise the ribbon to a greater or less degree, as for example, when it is desired to print in different colors, the ribbon being prepared with adjacent longitudinal bands or stripes of different colored ink for this purpose. The mechanism for accomplishing this variable throw of the ribbon will now be described.

A curved universal or actuating bar 9 is pivotally connected as at 10 to integral rearwardly extending arms 11 of the type bar guide plate 7, and is arranged to be depressed or swung downwardly about its pivotal points upon depression of a type key. Any improved means for depressing the bar 9 upon operation of the type keys may be employed, the specific form thereof forming no part of the present invention. An integral arm 12 extends at an angle from one end of the bar 9 near the pivotal point thereof and is connected by a link 13 to a lever 14 pivoted intermediate its ends as at 15 to an integral extension 16 of the type bar guide plate 7. The lower end of lever 14 is arranged to contact with the forward vertical face 17 of a bodily movable link 18 having a horizontal arm 19, the latter being pivotally con-

5 nected to one arm 20 of a bell-crank lever having also an angularly extending arm 21. The bodily movable link 18 is connected to a downwardly extending arm 22 of the escapement plate 23 of the carriage spacing mechanism. This connection preferably comprises a screw or similar lug secured to the lower end of arm 22 passing through an elongated slot 25 in the link 18, thus providing a sliding lost motion connection between the latter and the escapement plate 23.

10 Lying adjacent the arm 21 of the bell-crank lever is an oppositely disposed lever arm 26 pivoted at 27 to a bracket 28 secured to the frame, a spring 29 being connected to lever 26 and to a lug on bracket 28 and tensioned to tend to move the lever in a counter-clockwise direction about its pivotal point. This lever is connected at its forward end by a pin and slot connection 30 to the lower end of the ribbon support as clearly shown in Fig. 6. Lever 26 is provided intermediate its end with a portion 31 inclined to the general direction of length of the lever and having spaced longitudinally disposed slots 32 therein. Slidably mounted in these slots by means of pins 33 is a contact member or plate 34, the forward pin 33 extending laterally of the lever and forming a lug lying above the bell-crank arm 21 in position to contact therewith as shown in Figs. 4 and 5. The plate 34 is provided in the lower edge thereof with recesses 35 which are adapted to engage with a detent or spring 36 secured to lever 26, holding the plate in its adjusted positions. It will be understood that additional depressions in plate 34 may be provided, if desired, so as to hold the same in intermediate positions.

35 For shifting plate 34 from one position to another manual means are provided including a lever 37 pivoted intermediate its ends and having an upwardly extending operating arm lying in position for easy access by the operator. The lower end of this lever is pivotally connected to a link 38 the latter being pivotally connected to a lever 39 pivoted at its lower end to an extension of bracket 28, and connected at its upper end by a pin and slot connection including a pin 40 mounted on plate 34 and engaging in a slot in the lever 39. The forward end of link 38 is provided with an arm 41 spaced laterally from the point of connection of the lever with operating lever 37 and lying on the opposite side thereof for the purpose of supporting and guiding the members in their movement.

40 A foldable spacer bar for operating the escapement mechanism for releasing the carriage to spacing movement is provided as shown in Figs. 1, 2 and 3 this spacer bar comprises a finger piece 45 having secured to the underside thereof a metallic strip

46 having integral angularly disposed arms 47 pivoted at their ends to brackets 48 for supporting the spacer bar. A spring 49 is connected at one end to bracket 48 and at its opposite end to arm 47, being tensioned to support the parts in extended position as shown in Fig. 1. Spring 49 is disposed to swing across the pivotal connection between arm 47 and bracket 48 when the spacer bar is folded so as to support the same in folded position as shown in Fig. 2. An angularly disposed arm 50 integral with the plate 46 lies between supporting arms 47 in position to engage with a longitudinally slidable release rod 51 when the bar is in extended position as shown in Fig. 1. Release rod 51 is adapted to engage at its forward end (Fig. 9) with an extending arm 52 of the escapement plate 23, the rear end of the rod being guided by a lug 53 engaging with the cushion 54, forward movement of the rod being limited by engagement of the lug 53 with the rear side of the cushion. The rod 51 may be resiliently urged toward its forward position by means of a spring 55.

The operation of the mechanism which will be clear from the foregoing description briefly is as follows:—

95 When a type key is depressed the curved actuating bar 9 is rocked downwardly on its pivotal supports as will be understood, causing the ribbon support or vibrator 6 and ribbon to be raised through the connections provided by arm 12, link 13, pivoted lever 14, sliding link 18, bell-crank lever 20, 21, and lever 26. In the position of the parts shown in Fig. 5 it will be noted that the arm 21 contacts with the forward connecting pin or lug 33 carried by arm 26 at a relatively short distance from the pivotal point of the bell-crank lever and at a relatively long distance from the pivotal point of lever 26. It will be seen, therefore, that for a given moment of the bell-crank lever a relatively small movement will be imparted to the lever 26 and the ribbon support and ribbon will be raised a correspondingly short distance to bring the desired color stripe of the ribbon into printing position. It will be obvious that when the type key is released the mechanism returns automatically to its initial position, lowering the ribbon so as to afford a clear view of the writing. When it is desired to bring a differently colored stripe of the ribbon into printing position the ribbon support may be given a relatively large upward movement by moving the sliding plate 34 with its forward connecting pin 33 to the position shown in Fig. 6. This movement is accomplished by operation of the lever 37 the plate 34 being held in its adjusted position by engagement of the spring 36 and one of the recesses 35 on the lower edge

of the plate. In this position the connecting point between arm 21 and lever 26 is a relatively long distance from the pivotal point of the former and a relatively short distance from the pivotal point of the latter, and it will be obvious that a given angular movement of the arm 21 will impart a relatively large angular movement to the lever 26 and that the ribbon support 6 will be raised a corresponding distance to accomplish the desired result. If it is desired to print more than two colors it is obvious that a ribbon providing the additional colors may be provided, and the adjusting mechanism accordingly modified by providing additional depressions 35 in the sliding plate 34 so as to support the adjusting mechanism in any desired intermediate position.

As many changes could be made in the above construction and many apparently widely different embodiments of this invention could be made without departing from the scope thereof, it is intended that all matter contained in the above description or shown in the accompanying drawings shall be interpreted as illustrative and not in a limiting sense.

It is also to be understood that the language used in the following claims is intended to cover all of the generic and specific features of the invention herein described, and all statements of the scope of the invention which, as a matter of language, might be said to fall therebetween.

Having described my invention what I claim as new and desire to secure by Letters Patent is:

1. In a typewriting or like machine, the combination of a lever arm actuated at each printing operation, a ribbon vibrator, a second oppositely disposed lever arm connected to said ribbon vibrator, a contact member carried by one of said lever arms and having a sliding adjustment along the same to different set positions and co-operative directly with the other lever arm, a detent for said contact member, and manually actuated means for adjusting said contact member and thereby varying the extent of throw transmitted to the ribbon vibrator from said first mentioned lever arm through said contact member.

2. In a typewriting or like machine, the combination of a ribbon vibrator, a lever arm actuated at each printing operation, a second oppositely disposed lever arm pivoted at one end and connected at the other end to said vibrator and extending substantially parallel to said first mentioned lever arm, a contact through which motion is transmitted directly from said first mentioned lever arm to the second and which is carried directly by and has a sliding adjustment along one of said

lever arms to carry it nearer to the fulcrum of one lever arm and further from the fulcrum of the other, manually adjusted means for thus adjusting said contact member at will, and a detent co-operative with said contact member to hold it against accidental displacement from its adjusted position.

3. In a ribbon vibrating mechanism for writing machines, in combination, a ribbon support, a pivoted vibrating lever for actuating said support, a second pivoted lever arranged to be actuated by the operation of the writing machine and to actuate the first lever directly, said levers being disposed in parallel planes, a manually shiftable member provided with notches and disposed between said levers in a plane parallel thereto and arranged to provide a varying point of mechanical connection between said levers through which power is applied to the first lever from the second, and a resilient locking means on the first named lever adapted to engage with said notches to hold said member in one of a plurality of positions.

4. In a ribbon vibrating mechanism for writing machines, in combination, a ribbon support, a pivoted vibrating lever for actuating said support, a second pivoted lever arranged to be actuated by the operation of the writing machine and to actuate the first lever directly, a manually shiftable plate provided with notches disposed between said levers and provided with a pin arranged to serve as a varying point of common mechanical connection through which power is applied to the first lever through the second, and a resilient locking means on the first named lever arranged to engage with one of the notches on said plate whereby said plate is held in one of a plurality of positions.

5. In a ribbon vibrating mechanism for writing machines, in combination, a ribbon support, means actuated by operation of the writing machine for vibrating said support, means including a lever having a member movably mounted thereon to vary the point at which the lever receives motion from said actuating means, whereby to vary the amplitude of the vibration communicated to said support, said member being provided with a plurality of indentations, resilient means adapted to engage with said indentations for holding said member in different positions, and a manually operated means for shifting said member from one to another of its positions.

6. In a writing machine, in combination, a ribbon support, a lever operatively connected to said support, an adjustable plate shaped member having a lug associated with said lever, said member being provided with indentations, retaining means co-acting with said indentations to lock said member in adjusted position, and means co-operating with said lug for oscillating said support.

7. In a writing machine, in combination, a ribbon support, a lever operatively connected to said support, an adjustable plate shaped member having a lug slidably mounted on said lever, said member being provided with indentations, a spring pressed detent co-acting with said indentations to lock said member in adjusted position, means co-operating with said lug for oscillating said support, and manually operable means for adjusting said lug.

8. In a typewriting or like machine, the combination of a lever actuated at each printing operation, a ribbon vibrator, a second lever connected to said ribbon vibrator, a contact member carried by and adjustable along said second lever and co-acting directly with the first mentioned lever to transmit movement therefrom to the second lever, a detent carried by the lever which carries said contact member and co-acting with the latter for holding it against accidental displacement from its adjusted position, and means for adjusting said contact to vary the throw of the vibrator, said adjusting means comprising a manually operated lever, a link connected thereto, a second adjusting lever connected to said link, and a pin and slot connection between said second adjusting lever and said contact member.

9. In a typewriting or like machine, the combination of a ribbon vibrator, a universal bar, a lever actuated at each operation of said universal bar, a second lever pivoted at one end and connected at the other end to said ribbon vibrator, a contact member carried by and mounted for sliding adjustment along one of said levers and co-acting directly with the other lever and through which motion is transmitted from the first mentioned lever to the ribbon vibrator, a detent carried by the lever which carries said contact and co-operative with the latter to hold it against accidental displacement from its adjusted position, and a hand controlled adjusting lever operatively connected with said contact member by a pin and slot connection.

10. In a writing machine, in combination, a ribbon support, a pivoted lever operatively connected to vibrate said support, a second pivoted lever actuated by the operation of the machine, a plate shaped member having a pin and slot connection with said first

named lever and a lug engaging with an arm of said second named lever, whereby said plate may be adjusted to different positions to vary the amplitude of the vibration transmitted to said ribbon support from said second named lever, said plate shaped member having a plurality of indentations, and a resilient element on the said first named lever adapted to engage with said indentations in order to lock said plate shaped member in a plurality of different positions, and manual means for shifting said plate shaped member from one position to another.

11. In a writing machine, in combination, a ribbon support, a pivoted lever operatively connected to vibrate said support, a second pivoted lever actuated by the operation of the machine and having an arm cooperating with the first said lever to effect vibration of said support, said first named lever being provided with slots, and a sliding member secured in said slots on the first named lever for varying the point of applying power by the second lever to the first, said first named lever and said member being provided with a cooperating locking mechanism adapted to lock said member in one of a plurality of different positions.

12. In a writing machine, in combination, a rigid support, a pivoted lever operatively connected to vibrate said support, a second pivoted lever actuated at each printing operation and having an arm cooperating with the first named said lever to effect vibration of said support, said first named lever being provided with slots, a slidable plate provided with notches secured in said slots to said first named lever and arranged to provide an operative mechanical connection between said levers whereby the point at which power is communicated from the second lever to the first is varied, a resilient engaging member on said first named lever adapted to engage with said notches whereby the plate may be locked in one of a plurality of different positions, and manually operable means for shifting said plate to the different positions.

In testimony whereof I affix my signature, in the presence of two witnesses.

GEORGE GOULD GOING.

Witnesses:

A. W. AUSTIN,
N. M. SEIFERMAN.