

Aug. 25, 1936.

W. N. WILCOX

2,052,267

INDICATOR FUSE

Filed Oct. 18, 1935

Fig. 1.

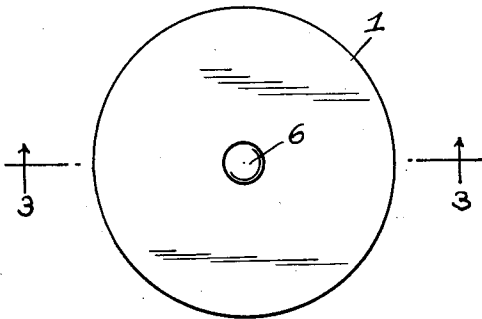

Fig. 2.

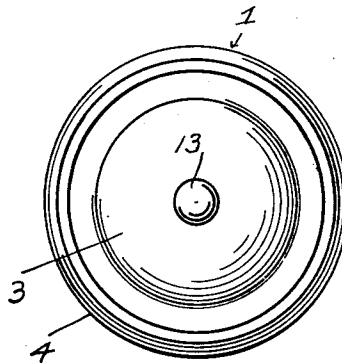

Fig. 3.

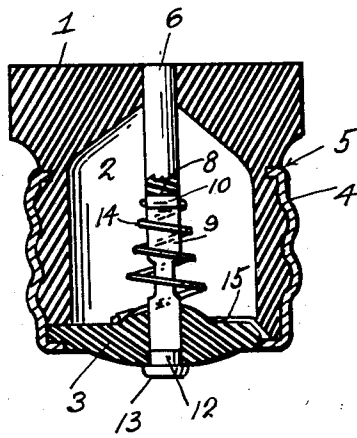

Fig. 7.

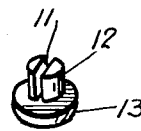

Fig. 4.

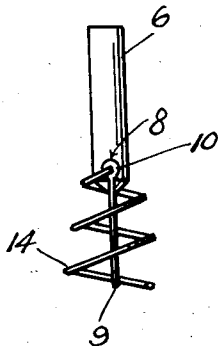

Fig. 5.

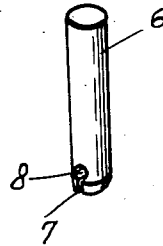
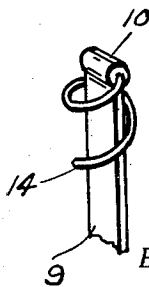

Fig. 6.



Inventor

W. N. Wilcox

By Clarence A. O'Brien
Attorney

UNITED STATES PATENT OFFICE

2,052,267

INDICATOR FUSE

Warren N. Wilcox, Ventura, Calif.

Application October 18, 1935, Serial No. 45,653

1 Claim. (Cl. 200—121)

This invention relates to an indicator fuse, the general object of the invention being to provide a plunger in the fuse plug which is normally in retracted position and which is projected from the front end of the plug when the fuse is destroyed so that one can readily tell the fuse has been blown by means of the projected plunger or running the hand over the front end of the plug to feel the projected plunger, if he is inspecting the fuses in the dark.

This invention also consists in certain other features of construction and in the combination and arrangement of several parts, to be hereinafter fully described, illustrated in the accompanying drawing and specifically pointed out in the appended claim.

In describing the invention in detail, reference will be had to the accompanying drawing wherein like characters denote like or corresponding parts throughout the several views, and in which:

Figure 1 is a top plan view of the device.

Figure 2 is a bottom plan view thereof.

Figure 3 is a section on the line 3—3 of Figure 1.

Figure 4 is a view of the plunger with the spring and fuse attached thereto.

Figure 5 is a view of the plunger alone.

Figure 6 is a fragmentary view of the fuse and showing how the spring is connected therewith.

Figure 7 is a view of the lower contact button.

In these views the numeral 1 indicates the fuse plug which is made of non-conductive material and which has a chamber 2 therein, the top of which is conical shape and the top of the plug has a circular opening therein which communicates with the apex of the conical portion of the chamber. The lower end of the chamber is closed by a member 3 of non-conductive material which is held in place by the metal threaded shell 4 which has a flange at its lower end overlapping the member 3 and a flange at its upper end which engages a groove in the exterior of the shell as shown at 5. The exterior of the plug is threaded to conform to the threads of the shell. A circular plunger 6 passes through the hole in the top of the plug and extends into the chamber and has a slot 7 in its inner end which opens out into a transverse circular hole 8 near the end of the plunger. The fuse is shown at 9 and has an elongated tubular part 10 at one end thereof which fits in the hole 8 with that part of the straight portion of the fuse adjacent the part 10 fitting the slot 7. The lower end of the fuse extends into a slot formed in the member 3 and enters a slot 11 formed in the shank 12 of a button 13, the fuse being soldered or otherwise connected to the shank. The shank and the button fitting in a

hole in the lower part of the member 3 and said button forms a central contact for the device. A spring 14 surrounds the fuse and has one end entering the tubular member 10 and soldered or otherwise connected therewith with the other end of the spring being extended as shown at 15 and passing between the member 3 and a part of the plug to the lower flange of the shell to which shell it is connected by solder or otherwise.

The parts are so formed and arranged that when the fuse is in good condition it will hold the plunger with its upper or outer end flush with the top or outer end of the plug as shown in Figure 3 and when the fuse blows the spring will project the plunger so that it will extend above the upper end of the plug and thus one noticing the projected plunger will know that the fuse has been destroyed or if he is in the dark he can run his hand over the top of the plug and feel the projected part of the plunger and thus know that the fuse has been destroyed.

It is thought from the foregoing description that the advantages and novel features of the invention will be readily apparent.

It is to be understood that changes may be made in the construction and in the combination and arrangement of the several parts, provided that such changes fall within the scope of the appended claim.

What is claimed is:—

A device of the class described comprising a plug formed of non-conductive material and having a chamber therein and a hole passing from the chamber through the top of the plug, a closure of non-conductive material closing the bottom of the chamber, a threaded metal shell surrounding the lower portion of the plug and holding the closure member in position, a plunger slidably passing through the hole, said plunger having a slot in the inner end thereof merging with a transversely extending bore therethrough, a flat fuse, one end of said fuse having a transversely disposed cylindrical enlargement receivable in the transversely disposed bore of the plunger, the adjacent flat portion of the fuse extending through said slot, a contact button carried by the closure and to which the other end of the fuse is connected, a spring surrounding the fuse, one end of the spring extending through an aperture in the enlarged cylindrical portion of the fuse, the other end of the spring being provided with an extension connected with the shell, said spring acting to project the plunger when the fuse is destroyed.

WARREN N. WILCOX.