

E. B. MATEJKA.
RAIL JOINT.
APPLICATION FILED MAR. 1, 1911.

1,000,832.

Patented Aug. 15, 1911.

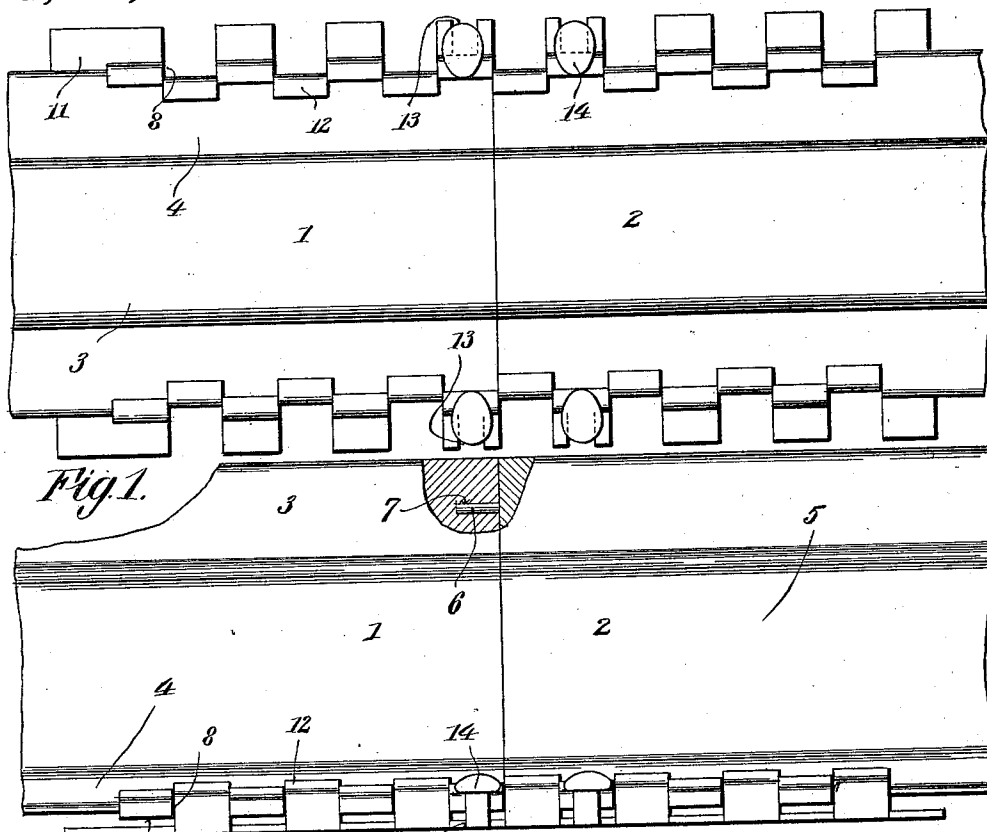

Fig. 1.

Fig. 3.

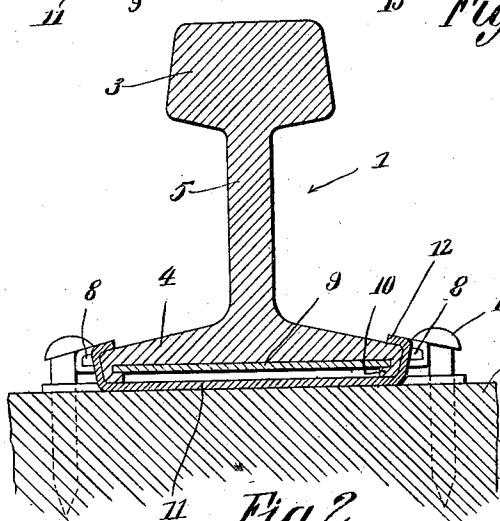

Fig. 2.

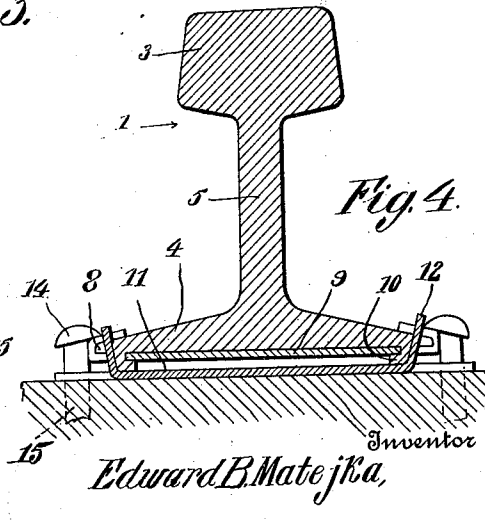

Fig. 4.

Witnesses

J. H. Crawford
Wm. J. North

Inventor

Edward B. Matejka,

By Victor J. Evans

Attorney

UNITED STATES PATENT OFFICE.

EDWARD B. MATEJKA, OF DENVER, COLORADO.

RAIL-JOINT.

1,000,832.

Specification of Letters Patent. Patented Aug. 15, 1911.

Application filed March 1, 1911. Serial No. 611,543.

To all whom it may concern:

Be it known that I, EDWARD B. MATEJKA, a citizen of the United States, residing at Denver, in the county of Denver and State of Colorado, have invented new and useful Improvements in Rail-Joints, of which the following is a specification.

This invention relates to improvements in rail joints, and the primary object of the invention is to provide a joint of this character which is of an extremely simple formation, which is cheap, which dispenses with the employment of fish plates or the like as well as obviating the necessity of weakening the rail ends by dispensing with the bolt holes usually formed therein and which provides a practically continuous rail.

With the above objects in view and others which will appear as the description progresses, the invention resides in the novel construction and arrangement of parts hereinafter fully described and claimed.

In the accompanying drawings Figure 1 is a top plan view of the meeting ends of a pair of rails constructed in accordance with the present invention. Fig. 2 is a transverse sectional view taken through one of the rails and chair. Fig. 3 is a side elevation of the device, one of the rails being shown partly in section. Fig. 4 is a transverse sectional view taken through the rails and chair and illustrating a slight modification.

In the accompanying drawings the numerals 1 and 2 designate the rails. These rails are constructed in the ordinary manner, each comprising a head 3, base flange 4 and connecting web 5. The head 3 of the rail 2 is provided with a projecting stud 6 and the head 3 of the rail 1 has its end provided with a recess or pocket 7 within which the stud 6 is adapted to be positioned when the rails are connected.

The base flanges 4 of each of the rails are provided, adjacent their ends, with equally spaced recesses; the under faces of the flanges are preferably provided with a reinforcing plate 9. Each of these plates is provided with recesses registering with the recesses 8 of the flanges and the metal between the said recesses is adapted to be bent over the edges of the flanges between the recesses 8 thereof. The recesses of the flanges

4 are formed by slitting the said flanges and the metal provided by the said slits may be bent inwardly to provide the ears 10 which underlie the reinforcing plate 9.

The numeral 11 designates the chair for the rails. This chair comprises a flat rectangular plate constructed of some suitable metal and the longitudinal edges of the chairs are provided with a plurality of transversely arranged slits. The metal between the slits is adapted to be bent upwardly to provide the fingers 12, and the said fingers are arranged so as to snugly engage the inner walls provided by the recesses 8 of the rail flanges 4. It is of course to be understood that the chair 11 is of a sufficient length to underlie both of the rails 1 and 2 and that the number of fingers corresponds with the number of the recesses 8 upon the flanges of both of the rails. The metal between the fingers 12 is notched as at 13, and these notches are adapted to receive the spikes 14 which are driven within the ties 15. The heads of the spikes are adapted to engage the portions of the flanges between their recesses 8, and it will be noted from the above description that when the rails are positioned upon the chair, lateral or longitudinal movement of the said rails is effectively prevented. The fingers 12 are adapted to be bent over the rail flanges as clearly illustrated in Figs. 1, 2 and 3 of the drawings, while in Fig. 4 I have illustrated the flanges upstanding or positioned at a right angle to the chair.

Having thus fully described the invention, what I claim as new, is:—

In a device for the purpose set forth, a pair of rail ends, one of said rails having its head provided with a stud, the second rail having its head provided with a pocket adapted to receive the stud, the flanges of each of the rails being slit, a plate under each of the rails, said plate provided with recesses, the slit portions of the flanges adapted to be inserted in the recesses of the plate and to be bent thereunder, the edges of the plate adjacent its recesses adapted to be bent over the flanges of the rails, a chair, said chair having its longitudinal edges slit, the metal between the said slits adapted to be bent upward to provide fingers, said fin-

gers adapted to be inserted within the recesses of the rails and plate and to be bent over the flanges of the rails, the longitudinal edges of the chair between the fingers being
5 notched, and each of said notches adapted for the reception of headed spikes, substantially as and for the purpose set forth.

In testimony whereof I affix my signature in presence of two witnesses.

EDWARD B. MATEJKA.

Witnesses:

GEO. M. FREDERICK,
PERCY W. BLANCHARD.

Copies of this patent may be obtained for five cents each, by addressing the "Commissioner of Patents, Washington, D. C."
