

[54] MULTI-COMPARTMENT STORAGE STRUCTURE

[75] Inventors: James Brompton Kruger, Oxford; Joseph Cooper, Westport, both of Conn.

[73] Assignee: Scovill Manufacturing Company, Waterbury, Conn.

[22] Filed: Nov. 14, 1972

[21] Appl. No.: 306,426

Related U.S. Application Data

[63] Continuation-in-part of Ser. No. 212,035, Dec. 27, 1971, abandoned.

[52] U.S. Cl. 312/351, 312/140, 312/257 R, 312/257 SK

[51] Int. Cl. A47b 43/00

[58] Field of Search.. 312/107, 111, 257 R, 257 SK, 312/257 SM, 259, 140, 294, 330

2,174,180	9/1939	Rand.....	312/140
2,274,765	3/1942	Zalkind.....	312/330 R
3,228,736	1/1966	Beckerman.....	312/140
3,316,041	4/1967	Nelson.....	312/140
3,399,941	9/1968	Hansen et al.....	312/257 R
3,429,632	2/1969	Simon et al.....	312/259
3,752,547	8/1973	Rrobst.....	312/107

Primary Examiner—James T. McCall
Attorney, Agent, or Firm—Dallett Hoopes

References Cited

UNITED STATES PATENTS

887,168 5/1908 Will..... 312/257 SK

[57] ABSTRACT

A multi-compartment storage structure has identical front and rear plastic molded frames. Top and side panels fit into channels in the frames and shelf panels are supported by cross pieces in the frames. A rear facing sheet is secured to the outer face of the rear frame.

4 Claims, 12 Drawing Figures

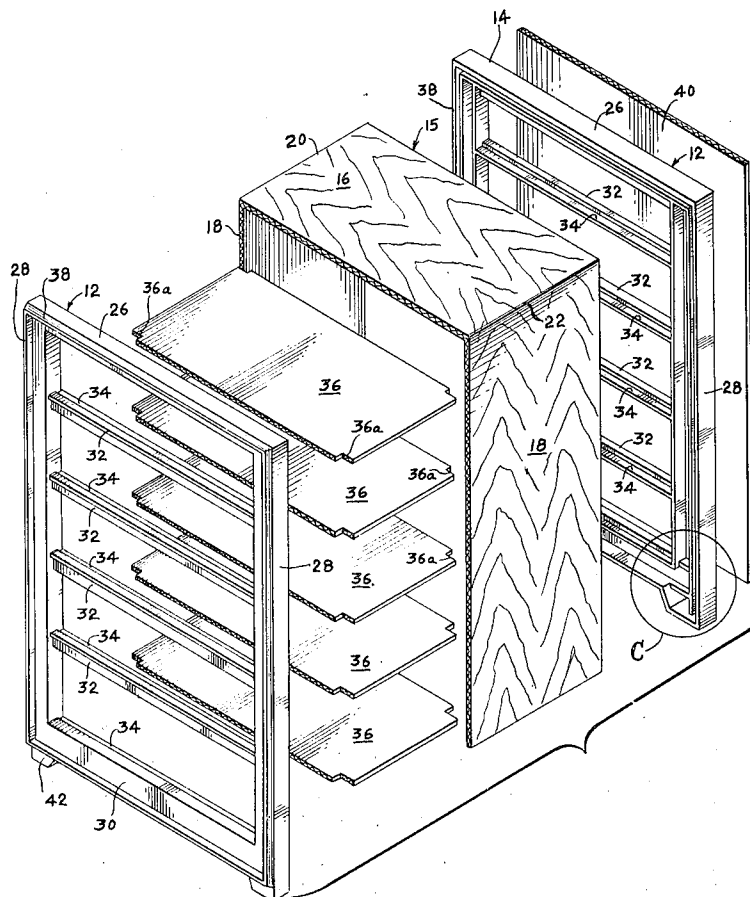

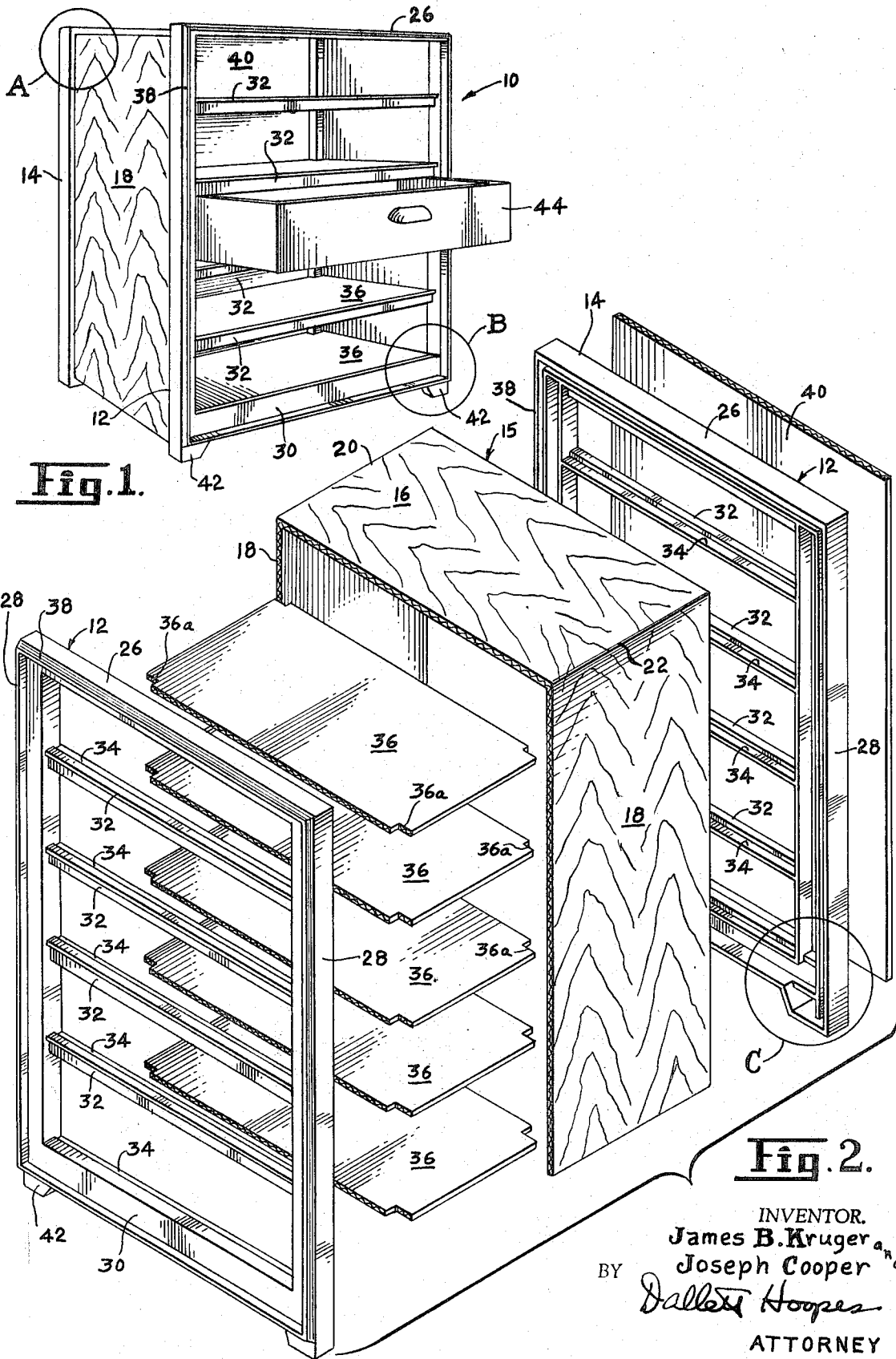

Fig. 1.

Fig. 2.

INVENTOR.
James B. Kruger and
Joseph Cooper
BY *Dallett Hoopes*
ATTORNEY

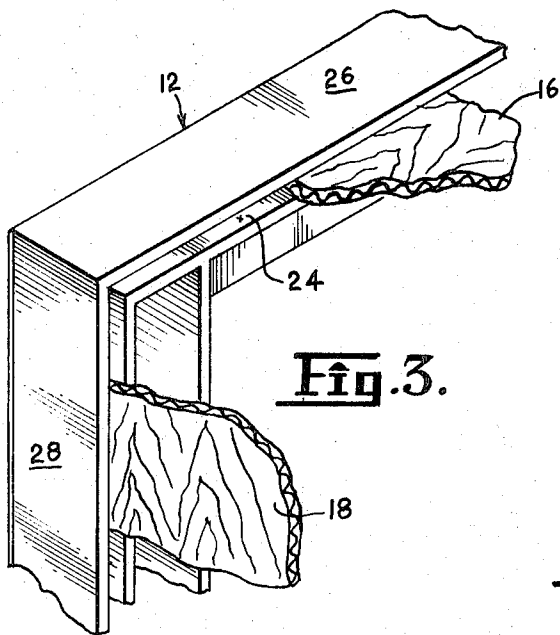

Fig. 3.

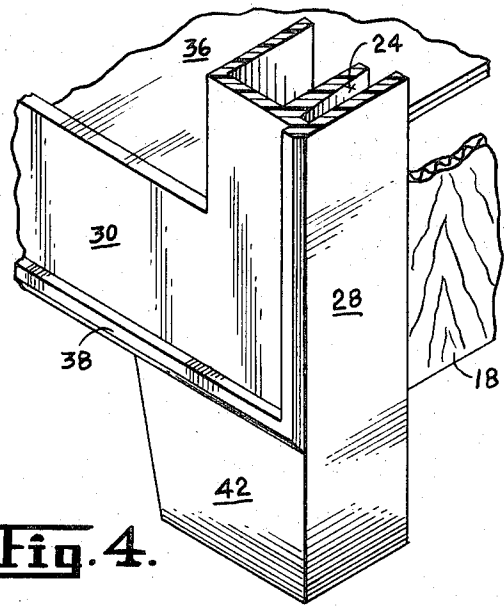

Fig. 4.

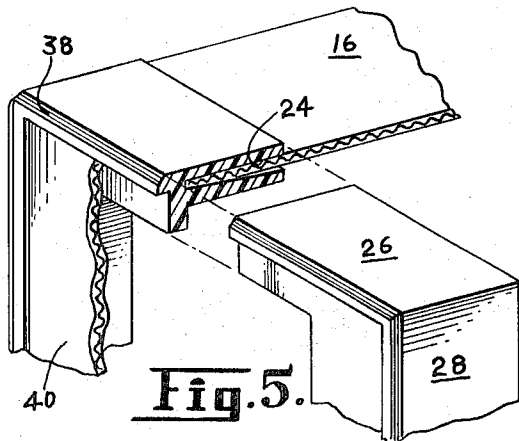

Fig. 5.

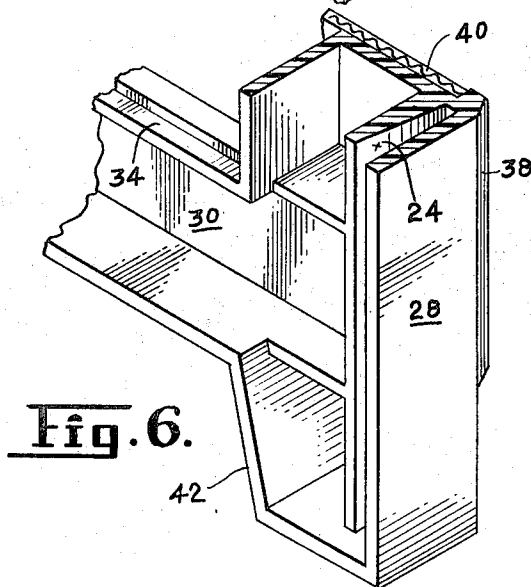

Fig. 6.

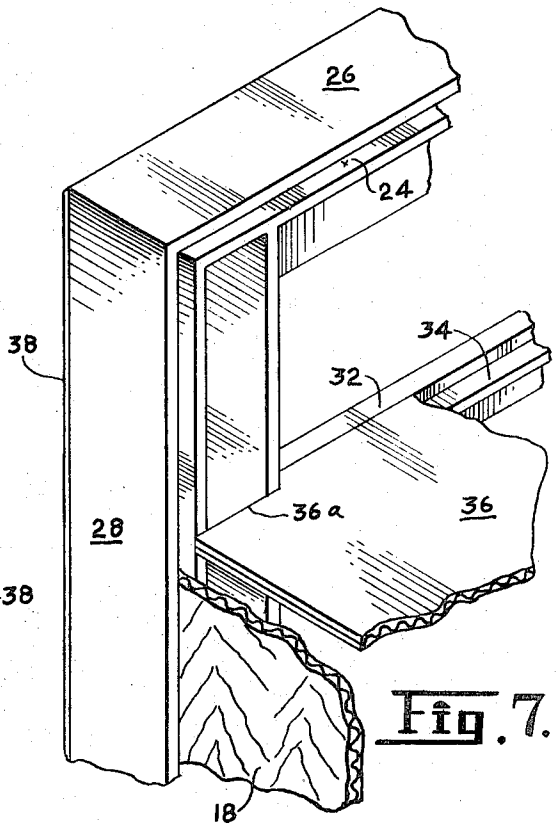

Fig. 7.

INVENTOR.
James B. Kruger and
Joseph Cooper
BY *Dallas Hoopes*
ATTORNEY

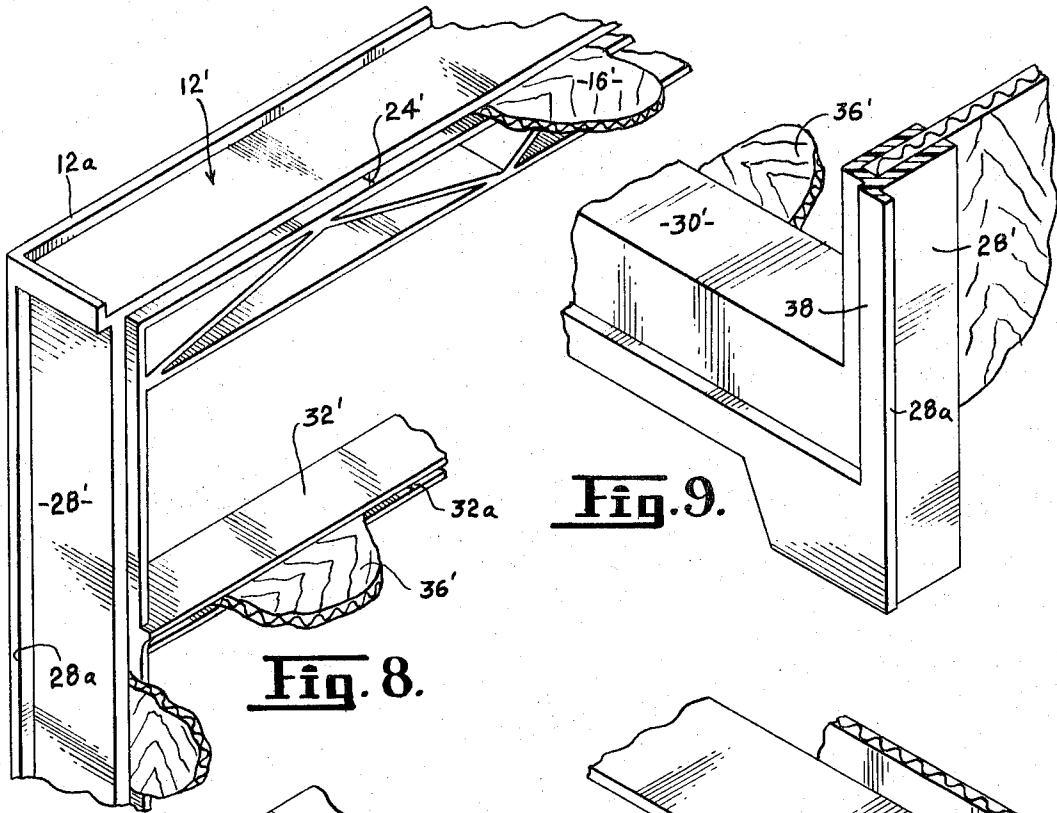

Fig. 8.

Fig. 9.

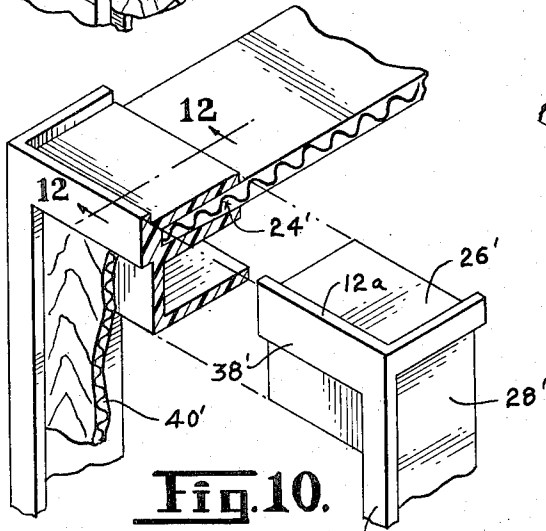

Fig. 10.

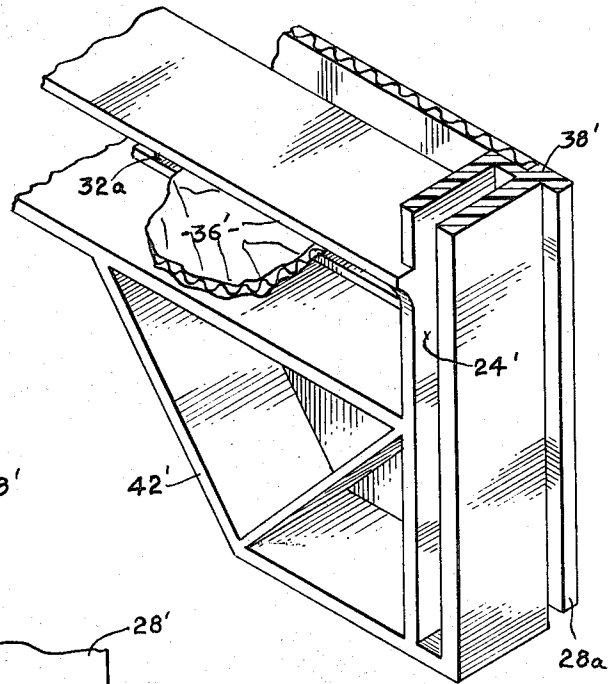

Fig. 11.

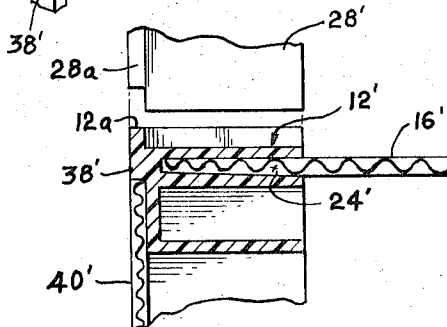

Fig. 12.

MULTI-COMPARTMENT STORAGE STRUCTURE

This application constitutes a continuation-in-part application of our co-pending patent application, Ser. No. 212,035, deposited in the United States Patent Office on Dec. 27, 1971, entitled "Multi-Compartment Storage Structure" now abandoned.

This invention relates to a multi-compartment storage structure. More specifically, this invention relates to an inexpensive storage structure in which the front and rear frames may be identical and molded of plastic.

In the past, chests and cabinets have been made of inexpensive construction such as corrugated board and wood, but have invariably required a frame made of many pieces of wood secured together as by gluing. The frames at front and back or opposite sides of the structure have rarely been identical and their incorporation into the structure and securing of shelves and panelling thereto has invariably involved use of fasteners such as staples, and much hand labor.

Under the present invention, there is provided a sturdy, multi-compartment, storage structure having identical front and rear frames of molded plastic construction. It provides a less expensive construction requiring a minimum of fasteners and hand labor, and a reduction in the number of pieces from which the structure is made.

Other objects of the invention will be apparent from the following specification including the drawings, all of which describe and show non-limiting embodiments of the invention. In the drawings:

FIG. 1 is a perspective view showing a chest of drawers embodying the invention with only one drawer part-way installed;

FIG. 2 is an enlarged exploded side perspective view taken from the opposite side from FIG. 1 and showing the various parts of the structure embodying the invention;

FIG. 3 is a fragmentary enlarged perspective view of the portion circled and indicated A in FIG. 1 and having part of the panelling broken away;

FIG. 4 is a fragmentary enlarged perspective of the area encircled in FIG. 1 and labelled B;

FIG. 5 is a fragmentary perspective view, broken and shortened, of the top portion of the front of the structure shown in FIG. 1 having a portion of panelling broken away;

FIG. 6 is an enlarged fragmentary perspective view of the portion shown in the circle labelled C in FIG. 2;

FIG. 7 is an enlarged perspective fragmentary view similar to FIG. 3 but showing a shelf installed against the top cross piece;

FIG. 8 is a view comparable to FIG. 3 of a modified version of the structure;

FIG. 9 is a view comparable to FIG. 4 but of a modified version of the structure;

FIG. 10 is a view comparable to FIG. 5 but of a modified version of the structure;

FIG. 11 is a view comparable to FIG. 6 but of a modified version of the structure; and

FIG. 12 is a sectional view taken on the line 12-12 of FIG. 10, and showing how plural structures may be stacked.

Referring more specifically to the drawings, a chest embodying the invention is generally designated 10 in FIG. 1. As shown well in FIG. 2, the structure includes

identical plastic molded front and rear frame portions 12 and 14. An inverted U-shaped panel 15 having top 16 and side walls 18 is provided. Preferably, this is formed of sheet material, such as corrugated board, in one piece, scored and bent along the corners 20 and 22.

As shown, the frames 12 and 14 each present on their inner face channels 24 which receive the front and rear edges respectively of the U-shaped panel (FIG. 3). The edges may be secured in the channels 24 by means of a cement. Preferably as shown in FIG. 6, for instance, the openings of channels 24 may be tapered to urge the outside glue-bearing surface into close contact with the frame. The panel 15 may be imprinted to look like wood.

Each of the frames 12, 14 comprise an open rectangle having a top element 26, side elements 28, and bottom element 30. Extending between the side elements 28 are a plurality of vertically spaced, horizontally disposed, cross pieces 32 which are part of the integral molded frame. As shown, each of the cross pieces and the bottom element 30 have adjacent their inward edge a downward step 34.

A plurality of shelves 36 are provided, preferably of sheet material similar to panel 15. These shelves 36 are substantially rectangular and each has opposite sides in the assembled structure resting respectively in the downward step 34 of horizontally-aligned cross pieces of the two frames 12, 14 (FIG. 7). The result is that the top of the edge of the shelf panels 36 is flush with the upper surface of the associated cross pieces 32 and bottom element 30 respectively. As shown, each of the generally rectangular shelf panels 36 has its corners notched as at 36a to accommodate portions of the frame side elements 28. The shelf panels 36 may be secured in place by cement, bonding them to the downward steps 34.

Each of the rectangular frame carries on its outer surface a perimetrical rib 38 which is provided on each of the elements 26, 28, 30, and is spaced outward from the edges of the elements which are adjacent the inside of the rectangle. A rear facing panel 40, which may also be of corrugated paperboard, is provided and is secured against the outward face of the rear frame and has its margins extending respectively to just short of the ribs on the frame (FIG. 5). This provides a smooth backing for the structure. The rib 38 on the outer side of the front panel 12 (FIG. 4) presents a pleasing decoration and strengthens the frame.

The side elements 28 extend below the bottom element 30 to provide feet 42 for the structure (FIGS. 4, 6).

As is shown especially well in the details of FIGS. 3 through 7, the plastic frames 12 and 14 may carry suitable reinforcing ribs, as is well understood in the art, to provide strength for the structure and to meet plastic molding convention and necessities.

In the structure, a drawer, such as is shown at 44 in FIG. 1, is provided in each of the openings above the bottom element 30 and cross pieces 32. Element 30 offers a kick panel.

Modified structure is shown in FIGS. 8 through 12. In these figures, the primed form of the same reference numeral is used to designate the part corresponding to the same part of the structure described above.

In the modified version shown in FIGS. 8 through 12, the openings for the drawers are enlarged to reduce the

proportionate width taken by the side elements. The side elements 28', as well as the top elements 12', are reinforced by outwardly extending flanges as at 28a and 12a, the flanges extending outward from the margins of the rib 38'. At the lower end of the structure, the flange 28a stops short to permit a nesting of parts when plural structures are stacked. Further, the cross pieces 32', instead of being stepped, have inwardly facing channels 32a adapted to receive the adjacent end of one of the substantially rectangular shelves 36'.

There is thus provided a storage structure of unusually simple construction and few number of inexpensive parts. It is unusually sturdy. Its manufacture involves a minimum of hand labor and it readily submits itself to decoration and practical use.

While the invention has been shown in but a single embodiment, variations are possible within the following claim language.

We claim:

1. A low-cost multi-compartment storage structure comprising identical molded plastic front and rear frames exposed on the outside of the structure and an inverted U-shaped said and top wall panel of corrugated paper board, the front and rear edges of which are secured respectively to the top and sides of the frames, each of the frames comprising: an integral plastic open rectangle having in the inner face of its top and side elements a panel-receiving channel into which the edges of the U-shaped panel are received, a plurality of vertically spaced horizontal cross pieces extending across the opening and integral with the side elements, the cross pieces each having a downward step along its top adjacent its inward edge, the outward face of the frame formed with an outward rib extending on all elements of the rectangle and spaced outward from edges of the elements adjacent the inside of the rectangle; a plurality of identical substantially rectangular shelves of sheet material, each having opposite sides respec-

tively resting in the downward step of horizontally-aligned cross pieces of the two frames; and a rear facing panel of sheet material secured against the outward face of one of the frames and having its margins extending respectively to just short of the ribs on the said frame.

2. A low-cost multi-compartment storage structure comprising identical molded plastic front and rear frames exposed on the outside of the structure and an inverted U-shaped side and top wall panel of corrugated paper board, the front and rear edges of which are secured respectively to the top and sides of the frames, each of the frames comprising: a plastic open rectangle having in the inner face of its top and side elements a panel-receiving channel into which the edges of the U-shaped panel are received, a plurality of vertically spaced horizontal cross pieces extending across the opening and integral with the side elements; a plurality of substantially rectangular shelves of sheet material, each having opposite sides respectively supported by the horizontally-aligned cross pieces of the two frames, each of the cross pieces having an inwardly facing channel receiving an adjacent edge of one of the shelves of sheet material; and a rear facing panel of sheet material secured against the outward face of one of the frames.

3. A multi-compartment storage structure as claimed in claim 2 wherein the outward face of the rectangle is formed with an outward rib thereabout spaced outward from the inner margin thereof and the rear facing panel is secured to the rectangle of the rear frame so that the edges of the panel are adjacent the inner edges of the ribs to provide a smooth backing.

4. A multi-compartment storage structure as claimed in claim 1 wherein the material of each of the shelf panels is notched at its corners to accommodate the side elements of the rectangular frame.

* * * * *

40

45

50

55

60

65