

No. 686,436.

Patented Nov. 12, 1901.

L. A. BAXTER.
CHURN.

(Application filed May 18, 1901.)

(No Model.)

2 Sheets—Sheet 1.

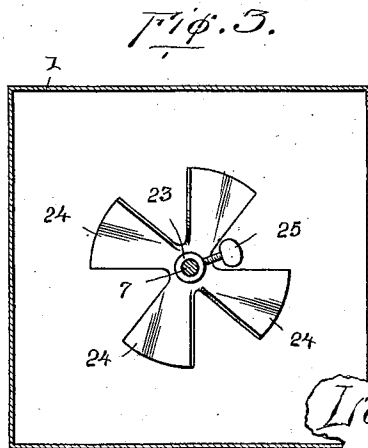
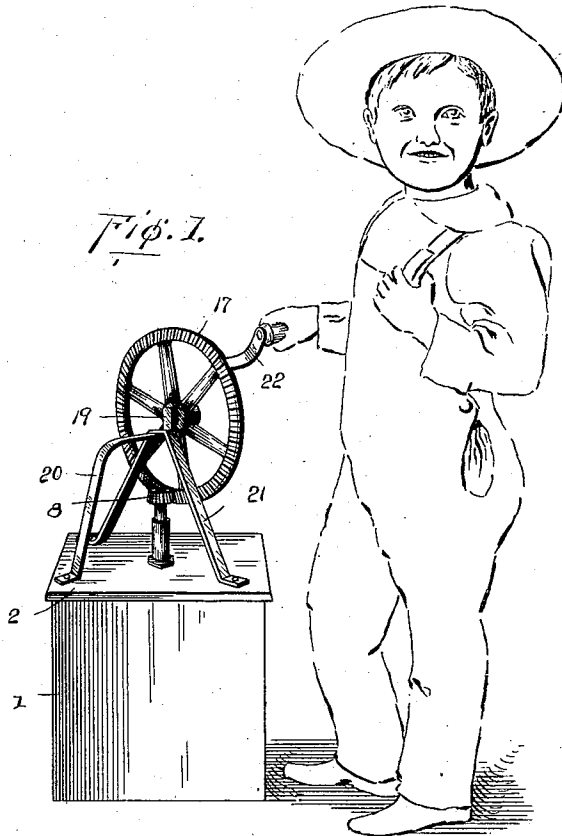

Witnesses

F. W. Bailey
Saisy Taylor

Inventor
Lionel A. Baxter,
by *Victor J. Evans*
Attorney

No. 686,436.

Patented Nov. 12, 1901.

L. A. BAXTER.
CHURN.

(Application filed May 18, 1901.)

(No Model.)

2 Sheets—Sheet 2.

Fig. 2.

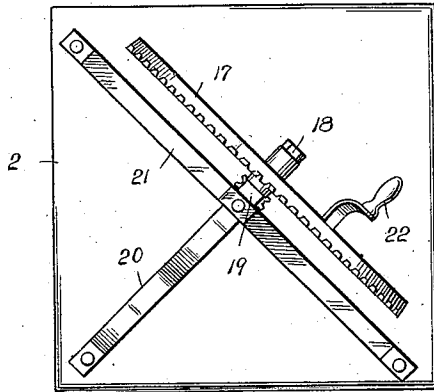

Fig. 4.

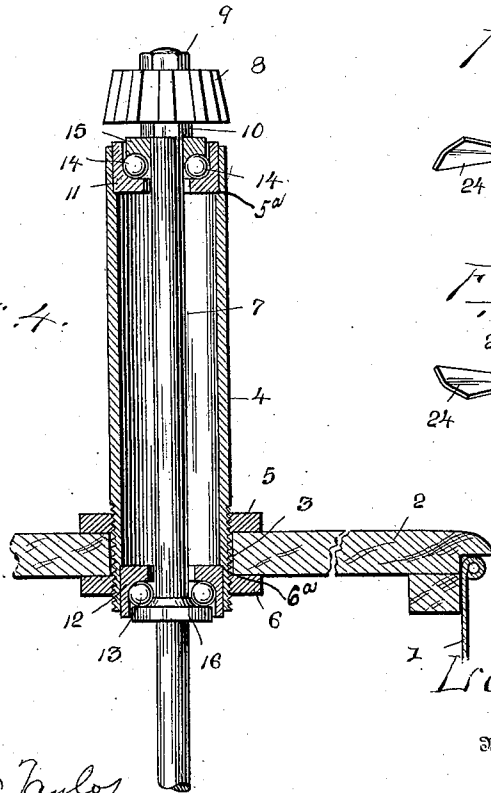

Fig. 5.

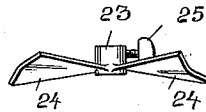
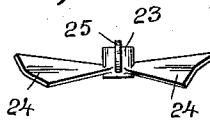

Fig. 6.



Witnesses

F. W. Bay
Daisy Taylor

Inventor
Lonnie F. Baxter

Victor J. Evans
Attorney

UNITED STATES PATENT OFFICE.

LONNIE A. BAXTER, OF GREENFIELD, OHIO.

CHURN.

SPECIFICATION forming part of Letters Patent No. 686,436, dated November 12, 1901.

Application filed May 18, 1901. Serial No. 60,877. (No model.)

To all whom it may concern:

Be it known that I, LONNIE A. BAXTER, a citizen of the United States, residing at Greenfield, in the county of Highland and State of Ohio, have invented new and useful Improvements in Churns, of which the following is a specification.

My invention relates to churns of the class which employ a rotary dasher; and the primary object of the invention is to provide improved means for supporting the dasher-shaft to insure an easy and rapid revolution thereof with the minimum of friction.

Further objects of the invention are to provide an improved form of dasher and novel means for supporting and bracing the crank by means of which the dasher is revolved.

The construction of the improvement will be fully described hereinafter in connection with the accompanying drawings, which form part of this specification, and its novel features will be defined in the appended claim.

In the drawings, Figure 1 is a view in perspective of a churn embodying the invention. Fig. 2 is a plan view of the same. Fig. 3 is a horizontal section showing a plan view of the improved dasher. Fig. 4 is a vertical section illustrating the means for supporting the dasher-shaft; and Figs. 5 and 6 are detail perspective views showing, respectively, the under and upper sides of the dasher.

The reference-numeral 1 designates the churn-body, which is shown as of rectangular form and provided with a cover 2, having a central opening to receive the lower end of a sleeve 4. This sleeve is externally threaded at its lower end and is supported in position within the opening of the cover 2 by means of jam-nuts 5 and 6, located, respectively, above and below the cover engaging the threads of the sleeve, as clearly shown in Fig. 4.

5^a and 6^a designate recesses providing seats in the ends of the sleeve 4 for the reception of the bearing-blocks 11 and 12.

7 designates the dasher-shaft, upon the upper end of which is mounted a bevel gear-pinion 8, which is secured in position by nuts 9 and 10.

11 and 12 designate ball-races, each formed with an opening through which the shaft 7

extends and being hollowed out to receive antifriction-balls 13 and 14. The balls 14 are supported in the raceway 11 by means of a cone-bearing 15, arranged upon the shaft 7, and the lower balls 13 are confined within the raceway 12 by a cone-bearing 16, mounted on the shaft 7 below the raceway 12.

The shaft 7 is adapted to be revolved by means of a bevel gear-wheel 17, which meshes with the gear-pinion 8 on the shaft 7. The gear-wheel 17 is mounted upon a stud-journal 18, supported in a bracket 19, projecting from an angle-arm 20, secured to the churn-cover and braced by a yoke 21, as is best shown in Fig. 1. The bevel gear-wheel 17 is provided with a crank-handle 22.

In connection with the shaft 7 and its supporting means I employ a dasher of the construction shown in Figs. 3, 5, and 6, comprising a central sleeve 23, through which the shaft extends, and a plurality of triangular radially-extending wings 24. Each of these wings 24 is bent longitudinally to incline the sides of the wings in opposite directions, and each wing is so bent that each of its edges projects in a direction opposed to the proximate edge of the adjacent wing. This construction insures a thorough agitation of the cream.

The dasher is adjustably secured to the shaft 7 by means of a set-screw 25.

It will be obvious that the shaft and dasher may be rapidly revolved with little effort and that by means of my improvement the churning process may be completed in a minimum of time.

I claim—

The combination with a churn-cover formed with an opening; of a sleeve having internal recesses forming seats within its ends, and having its lower end externally screw-threaded and extending through the opening in the cover, nuts located respectively above and below the cover and engaging the screw-threaded portion of said sleeve, bearing-blocks provided with ball-races and central openings and seated in said recesses, balls in said recesses, cones for holding said balls in their respective races and provided with central openings, a dasher-shaft extending

