



INTERNATIONAL APPLICATION PUBLISHED UNDER THE PATENT COOPERATION TREATY (PCT)

<p>(51) International Patent Classification ⁶ : B01J 19/00</p>	<p>A1</p>	<p>(11) International Publication Number: WO 97/10896 (43) International Publication Date: 27 March 1997 (27.03.97)</p>
<p>(21) International Application Number: PCT/US96/15124 (22) International Filing Date: 23 September 1996 (23.09.96) (30) Priority Data: 08/532,279 22 September 1995 (22.09.95) US 07/717,797 23 September 1996 (23.09.96) US (60) Parent Applications or Grants (63) Related by Continuation US 08/532,279 (CIP) Filed on 22 September 1995 (22.09.95) US 08/717,797 (CIP) Filed on 23 September 1996 (23.09.96) (71) Applicant (for all designated States except US): BERLEX LABORATORIES, INC. [US/US]; 15049 San Pablo Avenue, Richmond, CA 94804-0099 (US). (72) Inventors; and (75) Inventors/Applicants (for US only): MOHAN, Raju [IN/US]; 161 Selborne Way, Moraga, CA 94556 (US). BUCKMAN, Brad, O. [US/US]; 2042 Leimert Boulevard, Oakland, CA 94602 (US). MORRISSEY, Michael, M. [US/US]; 129 Alta Vista Way, Danville, CA 94506 (US). CHITTY, Andrew,</p>	<p>I. [US/US]; 3275 Fairview Way, West Linn, OR 97068 (US). MARTIN, John, T. [US/US]; 3705 S.W. Marquam Hill, Portland, OR 97201 (US). (74) Agents: MOSES, John, R. et al.; Millen, White, Zelano & Branigan, P.C., Arlington Courthouse Plaza I, Suite 1400, 2200 Clarendon Boulevard, Arlington, VA 22201 (US). (81) Designated States: AL, AM, AT, AU, AZ, BA, BB, BG, BR, BY, CA, CH, CN, CU, CZ, DE, DK, EE, ES, FI, GB, GE, HU, IL, IS, JP, KE, KG, KP, KR, KZ, LC, LK, LR, LS, LT, LU, LV, MD, MG, MK, MN, MW, MX, NO, NZ, PL, PT, RO, RU, SD, SE, SG, SI, SK, TJ, TM, TR, TT, UA, UG, US, UZ, VN, ARIPO patent (KE, LS, MW, SD, SZ, UG), Eurasian patent (AM, AZ, BY, KG, KZ, MD, RU, TJ, TM), European patent (AT, BE, CH, DE, DK, ES, FI, FR, GB, GR, IE, IT, LU, MC, NL, PT, SE), OAPI patent (BF, BJ, CF, CG, CI, CM, GA, GN, ML, MR, NE, SN, TD, TG). Published <i>With international search report.</i> <i>Before the expiration of the time limit for amending the claims and to be republished in the event of the receipt of amendments.</i></p>	

(54) Title: APPARATUS AND PROCESS FOR MULTIPLE CHEMICAL REACTIONS

(57) Abstract

Multiple chemical reactions are performed in a plurality of reaction vessels (12) mounted in inlets in a manifold valve block (30). The manifold valve block (30) is connected to a channel block (34) which is utilized in conjunction with a solvent delivery system (21) as part of the reaction cycle. The solvent fluid is drained from the reaction vessels (12) when valves in the manifold valve block (30) are opened while applying a vacuum thereto. Optionally, a thermal block (40) may be utilized in conjunction with the manifold valve block (30) and the channel block (34) to facilitate the reaction. Upon completion of the reactant cycle, the manifold valve block (30) is disconnected from the channel block (34) and connected to a cleavage block assembly (120, 121) which contains vials (128) for collecting reaction products. The cleavage product is drained from the reaction vessels (12) through the manifold valve block (30) into the vials (128) upon opening the valves in the manifold valve block (30) and applying a vacuum to the channel block (34).

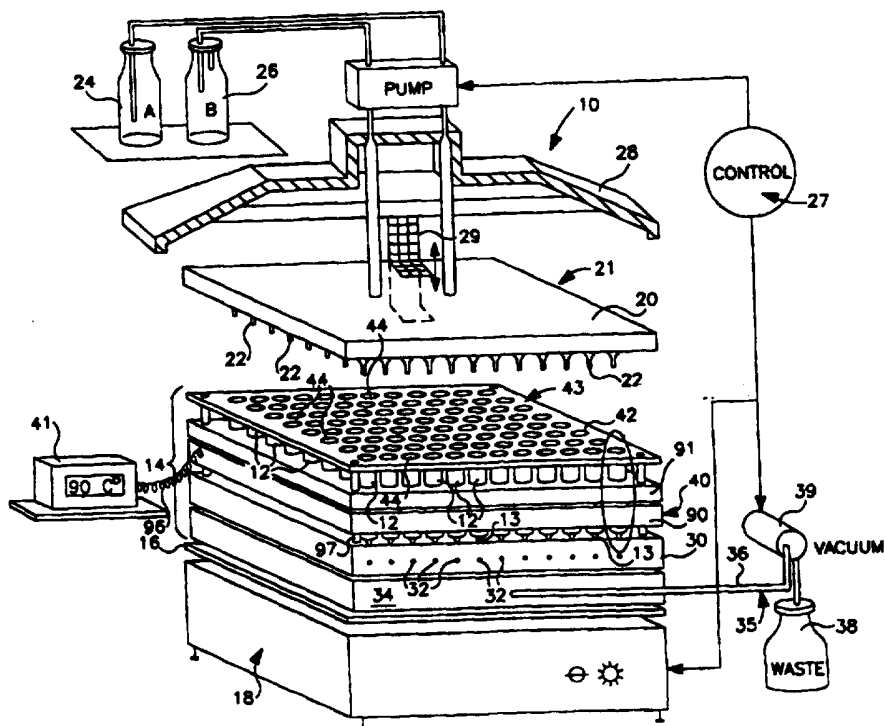

FOR THE PURPOSES OF INFORMATION ONLY

Codes used to identify States party to the PCT on the front pages of pamphlets publishing international applications under the PCT.

AM	Armenia	GB	United Kingdom	MW	Malawi
AT	Austria	GE	Georgia	MX	Mexico
AU	Australia	GN	Guinea	NE	Niger
BB	Barbados	GR	Greece	NL	Netherlands
BE	Belgium	HU	Hungary	NO	Norway
BF	Burkina Faso	IE	Ireland	NZ	New Zealand
BG	Bulgaria	IT	Italy	PL	Poland
BJ	Benin	JP	Japan	PT	Portugal
BR	Brazil	KE	Kenya	RO	Romania
BY	Belarus	KG	Kyrgystan	RU	Russian Federation
CA	Canada	KP	Democratic People's Republic of Korea	SD	Sudan
CF	Central African Republic	KR	Republic of Korea	SE	Sweden
CG	Congo	KZ	Kazakhstan	SG	Singapore
CH	Switzerland	LI	Liechtenstein	SI	Slovenia
CI	Côte d'Ivoire	LK	Sri Lanka	SK	Slovakia
CM	Cameroon	LR	Liberia	SN	Senegal
CN	China	LT	Lithuania	SZ	Swaziland
CS	Czechoslovakia	LU	Luxembourg	TD	Chad
CZ	Czech Republic	LV	Latvia	TG	Togo
DE	Germany	MC	Monaco	TJ	Tajikistan
DK	Denmark	MD	Republic of Moldova	TT	Trinidad and Tobago
EE	Estonia	MG	Madagascar	UA	Ukraine
ES	Spain	ML	Mali	UG	Uganda
FI	Finland	MN	Mongolia	US	United States of America
FR	France	MR	Mauritania	UZ	Uzbekistan
GA	Gabon			VN	Viet Nam

APPARATUS AND PROCESS FOR MULTIPLE CHEMICAL REACTIONS

Cross-Reference to Related Applications

This application is a continuation-in-part of U.S. Patent Application Ser. No. 08/532,279, filed September 22, 1995, and incorporated in its entirety by reference.

Field of the Invention

The invention relates to an apparatus and process for performing multiple chemical reactions, in particular for performing multiple solid phase chemical synthesis reactions and for isolating and collecting the final products of chemical reactions.

Background of the Invention

One of the key processes in solid phase chemical synthesis is the washing of the solid support resin which has a chemical template attached thereto. Multiple washing cycles with different solvents ensures that all excess reagents used during reaction cycles are washed from the resin. A typical protocol involves addition of a wash solvent, shaking the resin with the solvent for five minutes and then removing the wash solvent from the reaction vessel. In many instances, the wash solvent is drained from the bottom of the reaction vessel by applying a vacuum, i.e., filtering the resin free of the waste solvent. The task is further complicated when multiple solid phase syntheses are simultaneously carried out.

For example, if each reaction vessel is to be subjected to a filtration step, performing separate filtration on each individual reaction vessel can be very time consuming. Alternatively, if filtering is to be performed on all of the reaction vessels simultaneously, this can lead to a very complicated and awkward arrangement of apparatus with, for example, each individual reaction vessel being connected to a vacuum source by a separate vacuum hose.

As described above, the waste liquid is flushed out during the washing cycles typically by vacuum filtration. During reaction cycles, however, the solvent and the reagents are to be retained in the reaction vessel which by design has a filter at the bottom. Previously, when batch filtering from several sources, each source was connected to the filter by a line with each line having a stop-cock or valve to regulate drainage.

Summary of the Invention

Thus, an object of this invention is to provide a reaction apparatus for performing multiple chemical reactions on solid support in a parallel fashion which provides stable support for multiple reaction vessels and permits such tasks as washing and filtering to be performed simultaneously on all the reaction vessels in a simple and easy manner through a manifold design. A further object is to provide an apparatus to be used in association with the reaction apparatus, for cleaving reaction products from the solid support and separately collecting the reaction products from each of the individual reaction vessels.

Upon further study of the specification and appended claims, further objects and advantages of this invention will become apparent to those skilled in the art.

These objects are achieved at least in part in accordance with the invention by a reaction grid apparatus that can be used to perform multiple separate chemical reactions, the reaction grid comprising:

a first retaining member with a plurality of openings therethrough, each opening having an inlet and an outlet connected through a valve;

- 3 -

a separate reaction vessel for mounting in the inlet of each opening;
a drainage member having drainage channels therein aligned with the
outlets of the bores; and

5 a valve operator for operating at least several of the valves simultaneously to drain fluids from the reaction vessels into the drainage member.

Also, in accordance with the invention, a cleavage block assembly is provided for separately collecting reaction products from multiple separate reactions, the cleavage block assembly comprising:

10 a vial rack capable of supporting an array of separate vials;
a cleavage block section having a chamber therein for receiving the vial rack and a vacuum port for applying a vacuum to the chamber;

15 a reaction grid section having an array of openings there-through, each opening corresponding in position to a position in the vial rack, the reaction grid section including a valve associated with each opening;

an array of reaction vessels mounted in the openings in the reaction grid and having reaction products therein; and

members for securing the reaction grid section to the cleavage block section in sealed relation therewith.

20 In accordance with the invention, the reaction reagents and solvents are contained within each of the reaction vessels.

Further, in accordance with a process aspect, the invention provides a process for performing multiple reactions and separately collecting reaction products, the process comprising:

25 connecting reaction vessels to valved openings through a manifold block of a reaction grid;

loading each of the reaction vessels with solid support beads and attaching chemical templates to the solid support beads via linkers;

30 performing chemical synthesis reactions for the preparation of organic molecules within each of the reaction vessels;

removing fluid from the reaction vessels by opening the valved openings to drain the fluid to a channeled block by applying a vacuum to the channeled block;

5 washing the support solid support beads with wash solvent and removing the wash solvent from the reaction vessels by draining the wash solvent to a channel block;

removing the manifold block from connection with the channeled block and connecting the manifold block to a cleavage section, the cleavage section comprising a chamber containing a plurality of vial ports each holding a separate vial, each of the vial ports communicating with an inlet port of the manifold block, the cleavage section further comprising an outlet for connecting the chamber to a vacuum supply;

10 cleaving desired organic product from each of the reaction vessels and collecting the organic product within the individual vial.

15 The reaction grid in accordance with the invention enables the user to simultaneously carry out multiple chemical synthesis of desired molecules using solid phase chemical synthesis. Each of the multiple connection elements attached to the inlet ports of the reaction grid provide means for rigid and stable attachment of a reaction vessel such as a syringe barrel.

20 The reaction grid also allows the user to carry out several different steps in a chemical synthesis process in an integrated manner. Using standard protocols for solid phase synthesis, the reaction grid permits a user to simultaneously rinse or vacuum filter all of the reaction vessels. In addition, the user can perform different reactions simultaneously by utilizing different reagents in each of the reaction vessels during the synthesis mode. Furthermore, the reaction grid provides easy manipulation with respect to agitation. The reaction grid can be conveniently attached to a agitation device such as a wrist action shaker, vortexer or orbital shaker.

25
30 The plurality of inlet ports in the top surface of the reaction grid can be arranged in any suitable design. Preferably, the inlet ports are arranged in the form of a square or rectangular array having a certain number of rows

- 5 -

and columns. A square or rectangular array is preferred for ease of formatting and tabulating individual chemical products obtained from a matrix synthesis.

5 The reaction grid can be designed to provide any desired number of inlet ports for attachment of reaction vessels. In a preferable arrangement, the reaction grid has 96 inlet ports in a 12x8 array, this being the standard microtiter plate format used in industry for high throughput screening of compounds and biological assays. It is emphasized that other arrays, such as the smaller 5x8 array of parent application SN 08/532,279, filed
10 September 22, 1995, incorporated herein by reference, may be used in the practice of this invention.

Of course, even larger arrays, for example, a 100x100 matrix, can be provided in accordance with the invention. However, such large arrays require a large reaction grid which may require specialized agitation equipment and accessories for addition of solvents and reagents.
15

Each of the inlet ports is preferably equipped with a connection element that provides rigid and stable attachment of a reaction vessel to the inlet port.

In accordance with the preferred embodiment, the reaction vessels are
20 syringe barrels with a male Luer connection tip and a filter positioned at the end of the barrel. The connection element is preferably a female Luer-type connection element unitary with a valve insert in an opening through a first block of the reaction grid. Thus, when a reaction vessel is inserted into an inlet port, the male Luer connection tip of the syringe engages the female
25 Luer-type connector of the valve insert to provide a stable, rigid connection. Preferably, the Luer connections are unitary with the valve inserts in the manifold plate with the syringes of the reaction vessels being separate therefrom.

Preferably, valves are disposed between each of the male and female
30 connectors, with at least several of the valves being interconnected to operate simultaneously.

In accordance with a preferred embodiment, the reaction grid has an overall square or rectangular shape, and comprises two rectangular sections; a top section and a bottom section. The inlet ports pass through the entire thickness of the top section from its top surface, which is also the top surface of the grid, to its bottom surface. The bottom section, on the other hand, is provided with the substantially horizontal channels. By substantially horizontal, it is meant that the channels are oriented to provide drainage evenly from all of the reaction vessels without causing cross-contamination. Between the two square or rectangular sections a gasket is positioned to provide a vacuum seal between the top and bottom sections. Preferably, a groove for the gasket is machined into either the bottom surface of the top section, or the top surface of the bottom section. The gasket is then positioned within this groove. The top and bottom sections can be connected to each other by any suitable fastening means, for example, bolts or clamps.

After completion of the multiple reactions, a further development of the invention, the cleavage block assembly, can be used to separately collect the products from the individual reaction vessels. The cleavage block assembly comprises the top section or manifold section of the reaction grid, a vial rack capable of supporting multiple vials, and a cleavage block section having a chamber for holding the vial rack.

The vial rack supports an array of collection vials, which array corresponds to the array of inlet ports and reaction vessels of the top section of the reaction grid. The vials are held in a vertical orientation whereby fluid from each reaction vessel can flow through an inlet port into the mouth opening at the top of a vial.

In the cleavage block section, an internal chamber is provided which is adapted to hold the vial rack. Once the vial rack containing an array of vials is positioned within the internal chamber, the top section of the reaction grid is then positioned on top of the cleavage section and attached thereto by suitable fastening means, e.g., bolts or clamps. To facilitate drainage of the reaction vessels and collection of reaction products within

the individual vials, the cleavage section is provided with a vacuum port that communicates with the internal chamber. The vacuum port can be connected to a vacuum source to thereby apply a vacuum to the internal chamber. As a result, fluid is withdrawn from each of the reaction vessels and collected in the vials.

5

In accordance with a further aspect of the invention, the aforementioned objects, advantages, methods, systems and apparatus are further enhanced by performing fluid dispensing operations for washing and cleaving by employing a fluid dispensing system for simultaneously dispensing process fluids.

10

In accordance with still a further aspect of the invention, the aforementioned objects, advantages, methods, system and apparatus are further enhanced by heating or cooling the reactions.

Brief Description of the Drawings

15

Various other objects, features and attendant advantages of the present invention will be more fully appreciated as the same becomes better understood when considered in conjunction with the accompanying drawings, in which like reference characters designate the same or similar parts throughout the several views, and wherein:

20

Figure 1 is a side perspective view of an apparatus configured according to the present invention for supporting ninety-six reaction vessels, one of which is shown in enlarged isolation, in order to practice the process of the present invention;

25

Figure 2 is a perspective view of a valved manifold plate or block used with the apparatus of **Figure 1**;

Figure 3A is a side elevation of one of ninety-six valve inserts mounted in the manifold plate or block of **Figure 2**;

Figure 3B and 3C are side views of a valve stem used with an aligned array of valve inserts in the valved manifold plate of **Figure 2**;

Figure 4 is a top view of a valve manifold assembly with a multi-valve operator;

Figure 5 is a side view of the valve manifold assembly of Figure 4;

5 Figure 6 is an end view of the valve manifold assembly of Figures 4 and 5;

Figure 7 is a top view of a channel block used in conjunction with the valve manifold assembly of Figures 2-6 in the manner shown in Figure 1 and in Figures 32-34;

Figure 8 is a side view of the channel block of Figure 7;

10 Figure 9 is an end view of the channel block of Figures 7 and 8;

Figure 10 is a top view of a cap system plate assembly used with the manifold assembly of Figures 2-6 and the channel block assembly of Figures 7-9;

Figure 11 is a side view of the cap plate assembly of Figure 10;

15 Figure 12 is an end view of the cap plate assembly of Figures 10 and 11;

Figure 13 is a top view of a vortexer mounting plate upon which the manifold assembly of Figures 2-6, channel block assembly of Figures 7-9 and cap system of Figures 10-11, when assembled with one another, are mounted for agitation or stirring;

20 Figure 14 is a side view of the vortexer mounting plate of Figure 13;

Figure 15 is an end view of the vortexer mounting plate of Figures 13 and 14;

25 Figure 16 is a bottom view of a thermal block used with a reaction grid assembly shown in Figure 1;

Figure 17 is a bottom view of the thermal block assembly of Figure 16;

Figure 18 is an end view of the thermal block assembly of Figures 16 and 17;

30 Figure 19 is a side view of the reaction grid assembly ready for loading by a robotic loader;

Figure 20 is a side view of the reaction grid assembly with a wash system mounted thereon;

Figure 21 is a side view showing the reaction grid assembly mounted on a vortexer;

5 Figure 22 is a side view showing the reaction grid assembly and wash system mounted on the vortexer;

Figure 23 is a side view showing the cleavage system mounted on the vortexer;

10 Figure 24 is a top view of a vial rack assembly utilized with a cleavage system employed to collect reaction products after the reaction in the reaction vessels is complete;

Figure 25 is a side view of the vial rack assembly;

Figure 26 is an end view of the vial rack assembly of Figures 16 and 17;

15 Figure 27 is an exploded view, in perspective, of a preferred embodiment in which a composite vial rack having four sections mounted in the cleavage block;

Figure 28 is an exploded view showing the four vial rack section and a rack mounting tray of Figure 27;

20 Figure 29 is a top view of a cleavage system assembly which is comprised of the valve manifold assembly of Figures 4-6, and a cleavage block of Figures 35-37 which receives the vial rack assembly therein and the channel system assembly thereon;

25 Figure 30 is a side view of the cleavage system assembly of Figure 29;

Figure 31 is an end view of the cleavage system assembly of Figures 29 and 30;

30 Figure 32 is a top view of a reaction grid assembly which comprises the valve manifold assembly of Figures 4-6 and the channel block assembly of Figures 7-9 retained together with fasteners;

Figure 33 is a side view of the reaction grid assembly of Figure 32;

- 10 -

Figure 34 is an end view of the reaction grid assembly of Figures 32 and 33;

Figure 35 is a top view of a cleavage block used with the assembly of Figures 29-31;

5 Figure 36 is a side view of the cleavage block of Figure 35;

Figure 37 is an end view of the cleavage block of Figures 35 and 36;

Figure 38 is a top view of a robot deck mounting plate used to mount the reaction grid assembly while loading the vials of the reaction grid;

10 Figure 39 is a front view of the robot deck mounting plate of Figure 38;

Figure 40 is an end view of the robot deck mounting plate of Figures 38 and 39;

Figure 41 is a top view of a wash system manifold assembly used with the system of Figure 1;

15 Figure 42 is a side view of the wash system manifold assembly of Figure 41;

Figure 43 is an end view of the wash system manifold assembly of Figures 41 and 42;

Figure 44 is a diagrammatical view of a wash dispensing system;

20 Figure 45 is a diagrammatical view of a suction system for removing liquid from the assembly of Figure 1; and

Figure 46 is a diagrammatical view of a valve actuating system.

Detailed Description of the Drawings

Reaction Grid Structure

25 Referring now to Figure 1, there is shown a reaction station system 10, in accordance with the present invention, having an 8x12 array of reaction stations arranged in twelve columns and eight rows with each reaction station associated with a single reaction vessel 12 having a syringe tip 13. Each of the reaction vessels 12 is of a generally known configuration and
30 includes a filter 12 at a syringe tip 13 above which is a frit 12b is con-

- 11 -

figured as solid support beads upon which chemical templates are attached via appropriate linkers. The filter 12a normally holds liquids such as solvents and reaction products in the reaction vessels 12. As will be explained hereinafter, application of a partial vacuum to the syringe tip 13 evacuates these liquids from the plurality of reaction vessels 12 simultaneously.

5 Generally, the reaction station system 10 is comprised of a reaction grid assembly 14 which is fixed to a universal mounting plate 16 that is in turn attached to a vortexer 18. The vortexer 18 stirs the contents of the reactor vessels 12 by imparting a circular motion to the reaction grid 14.

10 Above the reaction grid 14 is a fluid delivery manifold 20 forming part of a liquid delivery system 21 which has an array of ninety-six injection probes in the form of needles 22 each of which is aligned with a separate reaction station for dispensing washing solvent from reservoirs 24 and 26 to the reaction vessels 12. Operation of the liquid delivery system 21 is controlled by a PLC controller 27. The reaction grid 14 and fluid delivery manifold 20 are covered by an exhaust hood 28.

15 The fluid delivery manifold 20 is preferably mounted on a wall or other support by an elevator system 29 which lowers and raises the fluid delivery manifold to deliver fluid to the reaction vessels via the needles 22. While the vortexer 18 is agitating the contents within the reaction vessels 12, the needles 22 are withdrawn from the reaction vessels 12 and spaced from the reaction grid 14.

20 The reaction grid 14 includes a manifold valve block 30 with the rows of valve operators 32 therein aligned with separate rows of valves for each reaction vessel so that the reaction vessels can be closed to retain solvents therein during the reaction stage of the process. The manifold valve block 30 also receives the syringe tip 13 of each reaction vessel 12. Beneath manifold block 30 is a channel block 34 which has channels therein for draining fluid out of the system via a drainage system 35. The drainage system 35 includes an exhaust line 36 connected to a waste vessel 38 and a vacuum pump which draws fluid from the reaction vessels 12 after the

- 12 -

valves in the manifold valve block 30, operated by the valve operators 32, have been opened. The controller 27 which operates the washing system 27, may also be used to operate the drainage system 35.

5 A thermal control block 40 with ninety-six apertures therethrough surrounds each one of the reaction vessels 12 to control the temperature of the reaction by either heating the contents of the reaction vessels or cooling the contents of the reaction vessels during the reaction.

10 A capping plate 42 overlies the open tops of the reaction vessels 12 and seals each reaction vessel. The capping plate 42 is part of a capping assembly 43 and includes ninety-six holes 44 therethrough, each of which holes is sealed by a silicon rubber septum sheet which is disposed between the capping plate 24 and the open tops of the reaction vessels 12. The needles 22 each simultaneously puncture the sealing material aligned with the holes 44 to deliver solvent to the reaction vessels. After the solvent has
15 been delivered to the reaction vessels 12, the fluid delivery manifold 20 is raised and the vortexer 18 agitates the ninety-six solutions in the ninety-six reaction vessels 12 for a selected period of time. Upon conclusion of the agitation, the valves operated by the valve operators 32 are opened and the washing fluid is drawn off through line 36. Fluid treatment may be repeated
20 a number of times with the same or different fluids, depending no the reaction sought in the reaction vessels 12 whether the reaction is anticipated or unanticipated. The reaction block 14 is disposed between the fluid dispensing system 27 and the drainage system 35 which are configured to facilitate rapid and convenient fluid treatment and processing of the contents in the
25 reaction vessels 12. The reaction station concept having been thus far described broadly, the following description sets forth in greater detail the structure and function of the various components shown in Figure 1.

30 Referring now to Figures 2 and 3A-C, where the manifold valve block 30 and associated insert valves are shown, it is seen that the manifold plate is in the form of a first polypropylene block having an upper surface 45, a lower surface 46 and side surfaces 47 with inlets 48 through the upper

- 13 -

surface 45 and outlets 49 through the lower surface 46. The inlets and outlets 48 and 49 are each connected by first passages 50, each of which first passages 50 receives a valve insert 51 (Figure 3A). Each valve insert 51 has a female Luer connector 52 at the top and a male Luer connector 53 at the bottom. Each female Luer connector 52 serves as an inlet into the manifold valve block 30 and receives the syringe tip 13 of one reaction vessel 12. Each male Luer connector 52 serves as an outlet for fluid passage from the manifold valve block 30. Each valve insert 51 further includes a lateral bore 54 therethrough which receives a valve stem 55 (see Figures 3B and 3C). The valve stem 55 is a rod having transverse holes 56 therethrough which are aligned with the axes of the female and male Luer connectors to allow for liquid to drain through the valve inserts 51 and are misaligned with the Luer connectors by rotation of the valve stems 55 to block the flow of liquid through the valve inserts. By rotating the valve stems 55, eight of the valve inserts 51 can be opened and closed simultaneously. The valve stems are received in second passages 57 through the block which intersect the first passages 50 and allow access to a plurality of first passages by a valve stem 55.

Referring now to Figures 4-6, there is shown an arrangement for operating all twelve of the valve stems 55 simultaneously so as to simultaneously block drainage from or allow drainage from the ninety-six reaction vessels 12 simultaneously. This is accomplished by fixing a link 60 non-rotatably to each valve rod 55 and connecting the links 60 to an actuator link 61. When one of the links 60 is opened or closed by rotating a handle 62, then the actuator link 61 causes every link 60 to rotate, closing or opening each of the ninety-six valve inserts 51 simultaneously.

Referring now to Figures 7-9, a second polypropylene block in the form of the channel block 34 is shown. The channel block 34 is a drainage block which is assembled together with the manifold valve block 30 for collecting waste fluid drained from the reaction vessels 12. The channel block 34 has a cavity therein defined by a series of interconnected channels 65

- 14 -

aligned with the female Luer connectors 53 of the valve inserts 51 in the manifold valve block 30 so that when the valve inserts are opened, the liquid therein simultaneously drains into the array of interconnected channels. There is a drain hole 66 in the array of interconnected channels which is connected by fluid passages in the channel block 34 to a quick connect drain fitting 68 that is in turn connected by the line 36 (see Figure 1) to a waste collector 68. Liquids, such as solvents in the reaction vessels 12 are pulled through the filters 12a in the reaction vessels 12 (see Figure 1) by a vacuum pump 39 (see Figure 1).

The channel block 34 has a face 69 with a surface groove therein which surrounds the area containing the open interconnected channels 65. The groove retains a gasket 72 therein. The gasket 72 seals with the bottom surface of the manifold valve block 30 so that when liquid is drained from the reaction vessels 12 through the valve inserts 51, it does not leak outside of the system 10. The channel block includes eight posts 70 which extend therefrom and pass through holes in the manifold valve block 30 to properly position the manifold valve plate with respect to the channel block. The assembly of the manifold valve block 30, or first block, and the channel block 34, or second block, is held tightly engaged by quick tighteners 71 which are received over and tightened about the posts 70. The face 69 is a coupling face allowing rapid assembly with the bottom surface 46 of the manifold valve block 30 which, in essence, provides a coupling face for the vessel retaining member (the manifold block 30) that mounts the reaction vessels 12.

Referring now to Figures 10-12 where the capping assembly 43 is shown, it is seen that the capping assembly 43 includes a rigid metal plate 74 and a polymeric system sheet 30 of non-chemically reactive, elastic, polymeric material. The polymeric material 76 underlies an array of ninety-six holes 78 in the plate 74, which holes align with the open tops of the vials 12 in the assembly of Figure 1. The polymeric septum sheet provides a closure for the open top of each reaction vessel 12. When the needles 22

- 15 -

(Figure 1) are lowered with the washing manifold 20, the needles pass through the holes 78 and penetrate the polymeric septum sheet 76 so that fluid from the reservoirs 24 or 26 can be injected into the reaction vessels 12. When the needles 22 are withdrawn, the material of the polymeric septum sheet seals the open tops of the reaction vessels 12 so that vapors are contained within the reaction vessels when the reaction vessels are agitated by the vortexer 18.

Referring now to Figures 13-15 where the vortexer 18 mounting plate 16 is shown, the vortexer mounting plate 16 is used to rigidly restrain the reaction grid assembly 14 (Figure 1) to the moving portion of the vortexer as the reaction grid assembly is agitated. The vortexer mounting plate 16 includes a base 80 with a back flange 81 and a pair of side flanges 82 and 83 which cooperate to hold the reaction grid assembly 14 (see Figures 1, 7-10) which is slid onto the base 80 from an open front 84 of the mounting plate 16.

Referring now to Figures 16, 17 and 18, there is shown the thermal control system 40 (see Figure 1) which is used to either heat the contents of the reaction vessels 12 or to cool the contents. The thermal control system comprises a bottom plate 90 and a top plate 91, the bottom plate 90 having ninety-six apertures 92 therein which align with ninety-six apertures 93 in the top plate 91. A silicon heating pad 95 is sandwiched between the top heater block 91 and the bottom heater block 90 and is connected by leads 96 to a heater control 41 (see Figure 1) which maintains the desired heat level. Four spacers 97 project from the bottom block 91 to keep the heater assembly slightly spaced from the manifold plate 30 in order to raise the thermal block assembly 40 to the level of the frit 12b in the reaction vessels 12. While the heating pad 95 is preferred, other heat approaches may be employed such as wrapping a heating plate, such as the plate 91, with wire to provide electric resistance heating 82 or circulating heated fluid through channels in the plate.

- 16 -

If it is desired to cool, rather than heat the reaction, the top block 91 has an indentation 98 therein for containing a cooling material such as, for example, dry ice. In another approach, cooled ethylene glycol may be circulated through channels in the top block 91. It is emphasized that the reaction system 10 of Figure 1 need neither be heated or cooled if the reactions in the reaction vessels 12 are to occur at room temperature, or if temperature control is not critical, in which case, the thermal block system 40 need not be used.

The reaction procedure is perhaps best understood in the context of Figures 19-22. In Figure 19, the reaction vessels 12 are assembled with the manifold valve block 30, the channel block 34 and capping plate assembly 20. This arrangement of parts is mounted on a robot deck mounting plate 100 for the loading phase of the procedure in which the reaction vessels 12 are loaded with fritts 12b and chemical linkers at a robotic loading site different from the site shown in Figure 1.

As is seen in Figure 20, the arrangement of Figure 19 is brought into contact with the fluid delivery system 21, which includes the needles 22 (Figure 1). In the fluid delivery system 21, a plurality of valves 110 in a manifold 112 are simultaneously opened by hydraulic cylinders 114 and 116 positioned on opposite sides of the manifold 112 to cause washing fluid or solvent from the container 24 (Figure 1) to flow into the ninety-six reaction vessels 12. While fluid is flowing into the reaction vessels 12, the ninety-six valve inserts 51 connected to each reaction vessel are held closed by the links 60 and operating handle 62 (also see Figures 4-6).

Referring now to Figure 21, after the reaction vessels 12 have been filled, the assembly of Figure 19 is disconnected from the washing manifold assembly 20 of Figure 20 and agitated by the vortexer 18.

Referring now to Figure 22, after agitation by the vortexer 18 has stopped, the valves 51 in the manifold valve block 30 are opened and the liquid in the reaction vessels 12 is drawn through the filters 12a in the reaction vessels and into the channel block 34 by suction applied to line 36

(see Figures 7-9) by the vacuum pump 39 (see Figure 1). Depending on the chemical processing being performed, the washing and evacuating step may be performed once or repeated a number of times with various fluids.

5 The reaction phase of the method employing the system of the present invention is now complete with the sought after reaction products bonded to the fritts 12b in the ninety-six reaction vessels 12. It is now necessary to cleave the reaction products from the fritts 12b and to collect the reaction products in vials. This is accomplished by the components of the cleavage system set forth in the following description.

10 The Cleavage System

As is seen in Figure 23, after the washing step of Figure 22, the manifold valve block 30 is separated from the channel block 34 and mounted on a cleavage block 120 to form a cleavage assembly 121 in which a vial tray rack 122 (shown in dotted lines) is mounted in a cavity
15 123 of the cleavage block 120. The cleavage block 120 is in turn retained on the universal mounting plate 16 mounted on the vortexer 18. The vial rack 122 is loaded with ninety-six one dram vials 128 for receiving the reaction products from the reaction vessels 12 upon simultaneously opening the valves 51 in the manifold valve block 30 (see Figures 3-6).

20 Referring now to Figures 24-26 where the vial rack 122 is shown removed from the cleavage block 120, it is seen that the vial tray has a top plate 130 with ninety-six holes 131 therethrough and a bottom plate 132 has ninety-six indentations 133 therein. The ninety-six vials 128 are mounted in the holes 131 with the bottoms of the vials resting in the inden-
25 tations 133. Since it is necessary to have the vial rack 122 recessed within the cavity 123 so as to provide clearance for the male Luer connectors 53 of the valve inserts 51 (see Figure 3), lifting pins 136 are provided which facilitate removal of the valve rack 122 from the cavity.

30 Referring now to Figures 27 and 28, where a second embodiment for supporting the vials 128 in the cleavage block 120 is shown, it is seen that

the second embodiment is a composite vial tray 140 having four segments 141, 142, 143 and 144. The four segments 141-144 are mounted on a vial rack mounting tray 145. As is seen in Figure 28, the four valve mounting racks 141-144 are separable into racks that hold twenty-four one dram vials 128 each. The vial racks 141-144 each fit in a speed vac which spins four racks per cycle.

The rack mounting tray 145 includes an array of pin holes 148 which array is unique for each of the racks 141-144 so that the racks have a unique location to facilitate identifying the reaction products in the vials 128. Pin holes 148 receive pins through holes 150 in the separate vial racks 141-144 to accomplish the alignment. Larger holes 152 in the vial rack mounting tray 145 can receive projecting knobs 156 to facilitate pulling the entire vial rack assembly from the cavity 123 in the cleavage block 120.

In order to facilitate handling and identifying the reaction products in the vials 148, separate bar codes 158 are located on each of the vial racks 141-144 and a bar code 159 is on the rack mounting tray 145 to identify the batch of ninety-six vials 128 containing reaction products cleaved in one operation.

Referring now to Figures 29-31 and Figures 32-34, it is seen that the cleavage block 120 receives the vial rack 122 of Figures 24-26 or the composite vial rack 140 of Figures 27 and 28 (only the vial rack 122 is shown). As is seen in Figures 29-31, in the cleavage operation, it is the cleavage block 120 which is attached to the manifold valve block 130, rather than the channel block 34 being attached to the manifold valve block 30, as is the case in Figures 32-34. The substitution of the cleavage block 120 for the channel block 34, is rapidly and conveniently accomplished by removing the quick connect fasteners 71 (also see Figure 8). From comparing Figures 29-31 to Figures 32-34, it is readily apparent that changing from the reaction phase to the cleavage phase is rapidly accomplished by simply substituting the cleavage block 120 for the channel block 34 by loosening and fastening the quick connect fasteners 71.

- 19 -

Further in this regard and referring to Figures 35-37, it is seen that the cleavage block 120 has a top structure which provides a coupling face 160 which is substantially identical to the top structure which provides the coupling face 69 of the channel block 34 shown in Figures 7-9 in that it has identically spaced attached attachment pins 70', as well as an identically placed gasket 72'. The coupling block 120 is, therefore, as stated, rapidly interchangeable with the channel block 34. Accordingly, it is readily apparent that the interface between the manifold valve block 30 and the channel block 34 is substantially identical to the interface between the manifold valve plate and the cleavage block 120. The channel block 120 also includes a quick connect fitting 160 for attachment to vacuum line 36 (see Figure 1).

Referring again to the assembly of Figure 23, after the reagent vessels 112 have been agitated by the vortexer 18, the ninety-six valves 51 in the valve manifold 30 are opened simultaneously by operating the handle 62 which rotates the linkages 60 to rotate the valve stems 55. With the opening of the insert valves 51, a vacuum is applied to the quick connect fitting 60 by the vacuum pump 39 which causes the solvent in the reaction vessels 12 which has cleaved the reaction products from the fritts 12b in the reaction vessels to flow with those reaction products into the array of ninety-six vials 128. The vials 128 are then removed from the cavity 123 in the cleavage block 120 and processed to separate the reaction products from the solvent.

Subcomponents and Systems

Figures 38-45 are directed to subcomponents and system which facilitate the operation of the aforescribed reaction grid system and cleavage system.

Figures 38-40 are views of the robot deck mounting plate 100 shown in Figures 19 and 20 which is used to mount the reaction grid assembly 14 on a robotic machine which loads chemical agents in the reaction vessels 12

- 20 -

prior to mounting the reaction grid assembly on the vortexer 18 shown in the reaction station system 10 of Figure 1.

5 Referring now to Figures 41-43 where the fluid dispensing manifold 20 is shown in greater detail, it is seen that the washing manifold 20 includes a plurality of the valves 110 operated by valve stems 172 positioned on opposite sides of the manifold 20 to release simultaneously fluids for the fluid treatment steps of Figures 20 and 22, upon activating the hydraulic cylinders 114 and 116 shown in Figures 20, 22 and 46 to release the wash- and reaction fluids in containers 24 and 26 of Figures 1 and 44.

10 Referring now to Figure 44, there is shown a washing fluid bottle 26 and a solvent bottle 24 (also see Figure 1) which are connected by valves 180 and 182 for selective dispensing of these liquids through a line 184 to the washing manifold 20 of Figures 1, 20, 22 and 41-43.

15 Referring now to Figure 45, there is shown the vacuum system for applying a vacuum to either the channel block 34 or cleavage block 120 via vacuum line 36 with waste washing fluid from the channel block 34 being accumulated in a waste container 38.

20 The resulting fluid dispensing apparatus, systems and methods resulting from combining the features of Figures 1, 20, 22, 44 and 46 enables rapid, simultaneous washing and treating of the contents in the 96 reaction vessels 12 while the evacuating system of Figure 45 cooperates with both the channel block 34 and the cleavage block 120 to remove the fluids from the reaction vessels 12 to the waste container 38 or the vials 128, respectively.

25 By utilizing the manifold valve block 30 to retain and release various washing fluids and the reaction products and an from the reaction vessels 12, as well as the selected fluid collection arrangement provided by channel block 34 and cleavage block 120, the convenience, speed and efficiency of simultaneously generating new compounds is further facilitated by employ-
30 ing the fluid handling system of Figures 1, 20, 22 and 41-46 therewith.

- 21 -

Referring now to Figure 46, there is shown a valve actuating system for gang actuating the valves of the washing manifold 112 shown in Figures 20, 22 and 41-43, wherein pneumatic cylinders 114 and 116 open valves 110.

EXAMPLE**Example 1 - Solid Phase Chemical Synthesis (General)**

The reaction grid is used to perform multiple solid phase chemical synthesis of organic molecules in a matrix format. The reaction vessels 12 are
5 filled with solid support resins and chemical templates are attached thereto via appropriate linkers. Subsequently, chemicals are added to the reaction vessels through the top of the syringe barrel, thereby permitting chemical transformations and reactions to occur on the templates attached to the solid support beads. The sealed reaction grid and filters used in the reaction
10 vessels 12 prevents chemical reagents from leaking out of the reaction vessels during the reaction cycles.

After a desired chemical transformation has been performed, the beads are rinsed free of excess chemicals in a wash cycle by the application of vacuum to the block. The vacuum source is connected to the block
15 through the outlet port. This allows liquid waste to drain from each of the reaction vessels through the inlet holes into the drainage channel and then to the main channel and finally into a waste trap. Subsequently, the beads are then washed repeatedly with wash solvent and again the waste removed by suction via the outlet connection port connected to the vacuum source.

20 Following completion of the transformations in each of the reaction vessels 12 and the washing and rinsing of the solid support resin, the manifold valve plate or block 30 is removed from the channel block 34. Thereafter, the manifold valve plate or block 30 is connected to a second block which is the cleavage block 120. In this assembly, the cleavage block
25 120 has individual receptacles or vials 128 corresponding to the number of reaction vessels/inlet ports in the array in the top section. Thus, in an 8x12 matrix design, there are ninety-six individual vials 128 or test tubes positioned within the cleavage block 120.

30 In comparing the cleavage block 120 to the channel block 34 of the reaction grid, the cleavage block is a hollow block containing individual

receptacles or vials 128 for the chemical products either in a tray or as a molded microtiter plate. The top section of the cleavage block 120 is the same as the top section of the channel block 34. In the cleavage block, the top sections and bottom sections are sealed to one another using an O-ring positioned therebetween just as in the reaction grid assembly 14. The male Luer connectors 53 of the valve inserts 51 (see Figure 3A) function as spouts to the cleavage block 120, draining into individual chambers (vials 128) rather than into connected channels 65 as in the case of the channel block 34.

10 **Example 2 - Solid Phase Chemical Synthesis (Specific Example)**

The following is a solid phase synthesis procedure for the synthesis of a library of 96 quinazoline analogs. These analogs are synthesized in an 8x12 matrix starting from a common anthranilic acid precursor. Treatment with 12 unique isocyanates and 8 unique alkylating agents provides 96 unique compounds.

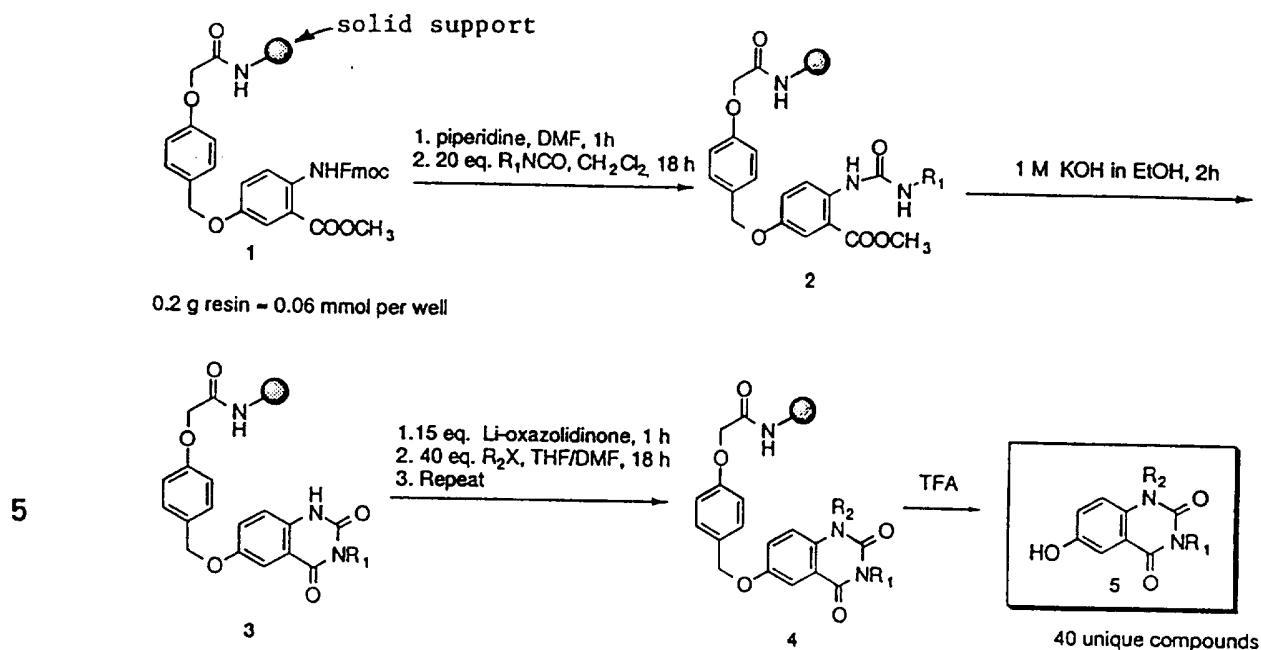
Solid Phase Organic Synthesis of 1,3-Dialkyl-2,4-Quinazoline Diones**Example of Solid Phase Synthesis of Quinazoline****Analogs Using the Reaction Grid Assembly**

5
10
15

Polymer (Tentagel-S NH_2) supported anthranilic acid derivative 1 is slurried in dimethyl formamide (DMF) and transferred to 96 individual reaction vessels 12 in an 8x12 matrix format (0.20 g, 0.06 mmol per vessel in 2 mL DMF). Piperidine (0.5 mL) is added to each vessel and the vessels are shaken for 1 h. The reaction grid assembly 14 is connected to a vacuum source via line 36 and the reaction solution is filtered away. DMF (2 mL) is added to each vessel 12 by using the washing system 21 of Figures 1, 20, 22, 41-44 and 46, and the vessels are shaken for 5 min., then drained via vacuum as described above using the drainage system of Figure 45. This rinsing step 35 is repeated three times. Methylene chloride (2 mL) is added to each vessel 12 and the vessels are shaken for 5 min., then drained via vacuum as described above. This rinsing step is repeated three times again

using the washing system 21 and the drainage system 35 provided by the manifold.

Methylene chloride (2 mL) is added to each vessel 12 and individual isocyanates (R_1) are then added to each vessel (8 different reagents, 1.16 mmol, 20 equivalents). The reaction grid assembly 14 is shaken for 18 hours to carry out the chemical transformation. Then the agitation is stopped, the vacuum port 68 of the reaction grid assembly 14 is connected to a vacuum source and the reaction solution filtered. Methylene chloride (2 mL) is added to each vessel 12 using the fluid handling manifold 20. The reaction grid assembly 14 is shaken for 5 min. and then drained via vacuum as described above using the drainage system 35. This rinsing step is repeated three times. Ethanol (2 mL) is added to each vessel 12 and the assembly 14 is shaken for 5 min., then drained via vacuum as described above. This rinsing step is repeated three times using the washing and drainage system 27 and 35. This operation now provides 8 unique urea derivatives 2.

1M Potassium hydroxide in ethanol (2 mL) is added to each vessel 12 and the assembly 10 shaken for 1 hour. The assembly 14 is connected to vacuum and the reaction solution is filtered away. Ethanol (2 mL) is added to each vessel 12 and the reaction grid assembly 14 is shaken for 5 min., then drained via vacuum as described above. This rinsing step is repeated three times using the washing and drainage systems 27 and 35, respectively. Tetrahydrofuran (2 mL) is added to each vessel 12 and the reaction grid assembly 10 is shaken for 5 min., then drained via vacuum as described above. This rinsing step is repeated three times. This operation now provides 8 unique monoalkylquinazolines 3.

Tetrahydrofuran (1 mL) is added to each vessel 12 followed by lithium benzyloxazolidinone (3 mL), 0.3 M in tetrahydrofuran, 0.90 mmol, 15.5 equivalents). The vessels are shaken for 1.5 hours. A different alkylating reagent (R_2) is now added down each of the 12 columns of the 8x12 grid. (12 different alkylating reagents, 2.32 mmol, 96 equivalents).

- 26 -

DMF (1 mL) is added to each vessel 12 and the vessels are shaken for 18 hours then the reaction grid assembly 14 is connected to vacuum via port 68 and the reaction solution is filtered away. The addition of lithium benzyloxazolidinone and alkylation agents is then repeated as described above. Tetrahydrofuran (2 mL) is added to each vessel 12 and the vessels are shaken for 5 min., then drained via vacuum as described above. This rinsing step is repeated three times. 50% Tetrahydrofuran in water (2 mL) is added to each vessel and the vessels are shaken for 5 min., then drained via vacuum as described above. This rinsing step is repeated three times. Tetrahydrofuran (2 mL) is added to each vessel 12 and the vessels are shaken for 5 min., then drained via vacuum as described above. This rinsing step is repeated three times. This operation now provides 96 unique dialkyl quinazolines 4, one in each reaction vessel 12, attached to the solid support.

The manifold valve block 30 with the attached reaction vessels 12 is separated from the channel block 34 and attached to cleavage block 120 to form the cleavage block assembly. A vial rack 122 or 140 is positioned within chamber 123 of cleavage block 120. 95% Trifluoroacetic acid in water (2 mL) is added to each vessel 12 using the fluid handling system 21 and the reaction vessels 12 are shaken for 3 hours. A vacuum source 38 is attached to vacuum port 160 of the cleavage block and the vessels 12 are filtered into 96 separate vessels, diluted with water and lyophilized to provide 96 unique dialkyl quinazolines 5.

Throughout this example, the washing and drainage systems 27 and 35, respectively, the reaction grid assembly 14 and the vortexer 18 are utilized to form the reaction products in the reaction vessels 12.

The preceding examples can be repeated with similar success by substituting the generically or specifically described reactants and/or operating conditions of this invention for those used in the preceding examples.

From the foregoing description, one skilled in the art can easily ascertain the essential characteristics of this invention, and without departing

from the spirit and scope thereof, can make various changes and modifications of the invention to adapt it to various usages and conditions.

WHAT IS CLAIMED IS:

1. A reaction grid system for use in performing multiple separate reactions, said grid comprising:
 - a vessel retaining member with a plurality of openings therethrough, each opening having an inlet and an outlet connected through a valve;
 - a plurality of reaction vessels for mounting individually in the inlets of the openings;
 - a drainage member associated with the vessel retaining member, the drainage member having a drainage field therein aligned with the outlets of the bores; and
 - a valve operator for operating at last several of the valves simultaneously to drain fluids from the reaction vessels into the drainage member.
2. The reaction grid system of claim 1, wherein the vessel retaining means is a block of material and the openings are passages through the material.
3. The reaction grid system according to claim 1, wherein said plurality of inlets are arranged in an array of at least two columns and at least two rows and the number of channels within said drainage member is equal to the number of rows in said array, wherein each inlet in a given row of said array communicates with a single channel.

- 29 -

4. The reaction grid system of claim 3, wherein the valves are interconnected to open and close simultaneously.

5. The reaction grid system of claim 2, wherein the valve operator includes valve portions in a single rod, wherein when the rod is moved, the valves of a simple column or row is opened or closed.

6. The reaction grid system of claim 5, wherein the valve portions are spaced openings in the rods which when aligned with the inlets and outlets allow fluid to pass therethrough and, when misaligned, block passage of fluid therethrough.

7. The reaction grid system of claim 6, wherein the rod is rotated to align and misalign the openings with the passages.

8. The reaction grid system of claim 5, wherein the valves are formed by inserts in each of the passages, the inserts each having radially extending precision bores formed therein for receiving precisely formed valve portions of the rods and having axially extending bores for providing fluid flow through the inserts, the fluid flow being controlled by the valve portions of the rods.

9. The reaction grid system according to claim 3, wherein each of said channels in the drainage member is in fluid communication with a main channel, wherein said main channel provides fluid communication between each of said channels and said at least one outlet port.

10. The reaction grid system according to claim 1 further including a coupling face on the vessel retaining member and a complimentary coupling face on the drainage member for detachably securing the drainage member to the vessel retaining member.

11. The reaction grid system according to claim 1, wherein the reaction grid further includes a capping assembly associated therewith for simultaneously closing each vessel with a closure portion, which closure portion is configured to admit fluid when penetrated.

12. A reaction grid system according to claim 11, wherein the closure portion is an elastomeric material providing an opening therethrough when penetrated by a probe.

13. The reaction grid system according to claim 12 further including a coupling face on the vessel retaining member and a complimentary coupling face on the drainage member for detachably securing the drainage member to the vessel retaining member.

14. The reaction grid system of claim 13 further including a cleavage assembly having a coupling face attachable to the coupling face of the vessel retaining member, the cleavage assembly including a plurality of reaction product collection vials aligned with the outlets of the vessel retaining member when the drainage member is detached from the vessel retaining member and the cleavage assembly is attached to the vessel retaining member.

15. The reaction grid system of claim 14 further including a solvent delivery system comprising an array of probes corresponding to the array of closures in the capping system, wherein a probe is aligned with each closure for selectively penetrating that closure to deliver liquid simultaneously to each reaction vessel.

16. The reaction grid system of claim 15 further including a vacuum system connectable to the drainage member for applying a vacuum thereto for evacuating fluids therefrom and for applying a vacuum to the cleavage

assembly to cause reaction products in the reaction vessels to drain to the collection vials.

17. The reaction grid system of claim 16 further including a thermal control arrangement juxtaposed with the reaction vessels for heating or cooling the contents of the vessels.

18. The reaction grid assembly of claim 17 further including an agitator for agitating the contents of the reaction vessels.

19. The reaction grid system of claim 16 further including an agitator for agitating the contents of the reaction vessels.

20. A manifold block useful for supporting an array of reaction vessels, the manifold block comprising:

a block of resinous material having an upper surface, a lower surface and side surfaces;

an array of first passages through block from inlets at the upper surface to outlets at the lower surface;

an array of second transverse passages extending through the block, each second transverse passage intersecting a plurality of first passages, whereby the inlets of the first passages each receive one of the reaction vessels and the second passages provide access to pluralities of first passages for controlling flow of fluid from the reaction vessels out through the outlets in lower surface of the block.

21. An assembly comprising the manifold block of claim 20 and further comprising:

a capping assembly attached to the manifold block in spaced relation thereto, the capping assembly sealing inlets of the reaction vessels when the reaction vessels are mounted in the inlets of the manifold block.

- 22.** An assembly comprising the manifold block of claim 20 and further comprising:
- a drainage block attached to the manifold block, the drainage block having at least one cavity therein for receiving fluid from the reaction vessels when fluid in the reaction vessels flows from the outlets in the manifold block.
- 23.** The assembly of claim 22, wherein drainage block has interconnected channels therein aligned with the outlets of the manifold block.
- 24.** The assembly of claim 23 further including:
- a capping assembly attached to the manifold block in spaced relation thereto, the capping assembly sealing inlets of the reaction vessels when the reaction vessels are mounted in the inlets of the manifold block.
- 25.** An assembly comprising the manifold block of claim 20 and further comprising:
- a valve insert in each of the first passages.
- 26.** The assembly of claim 25 further including valve operators extending in each of the second passages to simultaneously operate valve inserts in the first passages.
- 27.** The assembly of claim 26 further including a drainage block attached to the manifold block, the drainage block having at least one cavity therein for receiving fluid from the reaction vessels when fluid in the reaction vessels flows from the outlets in the manifold block.
- 28.** The assembly of claim 27, wherein drainage block has interconnected channels therein aligned with the outlets of the manifold block.

- 33 -

29. An assembly comprises the manifold block of claim 27 and further comprising:

a capping assembly attached to the manifold block in spaced relation thereto, the capping assembly sealing inlets of the reaction vessels when the reaction vessels are mounted in the inlets of the manifold block.

30. An assembly comprising the manifold block of claim 20 and further comprising:

a thermal block held spaced from the manifold block for surrounding the reaction vessels when the reaction vessels are mounted in the inlets of the manifold for controlling the temperature of contents within the reaction vessels.

31. The assembly of claim 30 further including:

a drainage block attached to the manifold block, the drainage block having at least one cavity therein for receiving fluid from the reaction vessels when fluid in the reaction vessels flows from the outlets in the manifold block.

32. The assembly of claim 26 further including:

a capping assembly attached to the manifold block in spaced relation thereto, the capping assembly sealing inlets of the reaction vessels when the reaction vessels are mounted in the inlets of the manifold block.

33. The assembly of claim 31 further including:

a valve insert in each of the first passages.

34. The assembly of claim 33 further including valve operators extending in each of the second passages to simultaneously operate valve inserts in the first passages.

- 34 -

- 35.** The assembly of claim 30 further including:
a capping assembly attached to the manifold block in spaced relation thereto, the capping assembly sealing inlets of the reaction vessels when the reaction vessels are mounted in the inlets of the manifold block.
- 36.** The assembly of claim 35 further comprising:
a valve insert in each of the first passages of the manifold block.
- 37.** The assembly of claim 36 further including valve operators extending in each of the second passages to simultaneously operate valve inserts in the first passages.
- 38.** The assembly of claim 35 further comprising:
a drainage block attached to the manifold block, the drainage block having at least one cavity therein for receiving fluid from the reaction vessels when fluid in the reaction vessels flows from the outlets in the manifold block.
- 39.** The assembly of claim 38, wherein drainage block has interconnected channels therein aligned with the outlets of the manifold block.
- 40.** The assembly of claim 38 further including:
a valve insert in each of the first passages of the manifold block.
- 41.** The assembly of claim 40 further comprising:
an agitation device for agitating the contents of the reaction vessels.
- 42.** The assembly of claim 41, wherein the agitation device is a vortexer.

43. An assembly comprising the manifold block of claim 20 and further comprising:

a vial retaining member for coupling to the lower surface of the manifold block and for holding a plurality of vials in alignment with the outlets of the manifold block.

44. The assembly of claim 43, wherein the vial retaining member is a cleavage block having a cavity therein in which the vials are received.

45. The assembly of claim 44 further comprising:

a capping assembly attached to the manifold block in spaced relation thereto, the capping assembly sealing inlets of the reaction vessels when the reaction vessels are mounted in the inlets of the manifold block.

46. The assembly of claim 44, further comprising:

a valve insert in each of the first passages.

47. The assembly of claim 46 further including valve operators extending in each of the second passages to simultaneously operate valve inserts in the first passages.

48. The assembly of claim 46 further comprising:

a capping assembly attached to the manifold block in spaced relation thereto, the capping assembly sealing inlets of the reaction vessels when the reaction vessels are mounted in the inlets of the manifold block.

49. The assembly of claim 44 further comprising:

a thermal block held spaced from the manifold block for surrounding the reaction vessels when the reaction vessels are mounted in the inlets of the manifold for controlling the temperature of contents within the reaction vessels.

50. The assembly of claim 49 further comprising:
a valve insert in each of the first passages.

51. The assembly of claim 50 further including valve operators extending in each of the second passages to simultaneously operate valve inserts in the first passages.

52. The assembly of claim 49 further comprising:
a capping assembly attached to the manifold block in spaced relation thereto, the capping assembly sealing inlets of the reaction vessels when the reaction vessels are mounted in the inlets of the manifold block.

53. The assembly of claim 52 further comprising:
a valve insert in each of the first passages.

54. The assembly of claim 53 further including valve operators extending in each of the second passages to simultaneously operate valve inserts in the first passages.

55. The assembly of claim 54 further comprising:
an agitation device for agitating the contents of the reaction vessels prior to transferring the contents to the collection vials.

56. The assembly of claim 55 further including a mounting plate for supporting either the drainage block or the cleavage block on the agitator.

57. A vial retaining block assembly for containing a plurality of vials arranged in an array for receiving reaction products from an array of reaction vessels, the vial retaining block assembly comprising:

a block having a cavity therein and a coupling face, the coupling face including a seal and fastening means;

a vial rack disposed in the cavity, the vial rack including an array of holes for supporting the vials; and

a port in the body of the block in communication with the cavity, whereby when a vacuum is applied to the port, a partial vacuum occurs in the cavity to facilitate flow of the reaction products from the reaction vessels to the vials.

58. The assembly of claim 57, wherein the vial rack includes at least one gripping member extending therefrom for facilitating withdrawing the rack from the cavity in the block.

59. The assembly of claim 57, wherein the vial rack is comprised of an upper plate with the arrangement of holes therein and a lower plate spaced from the upper plate, the lower plate having an array of depressions therein aligned with the holes for seating the bottoms of the vials.

60. The assembly of claim 57, wherein the vial rack is a composite rack having more than one vial retaining section, the vial retaining sections being separable from one another when out of the cavity.

61. The assembly of claim 60, wherein each vial retaining section has a separate code marked thereon.

62. The assembly of claim 61 further including a support for the vial retaining sections, the support having a code specific thereto marked thereon.

63. The assembly of claim 62, wherein the codes are bar codes.

64. The assembly of claim 62, wherein the vial retaining sections have location specific couplings thereon which cooperate with location specific couplings on the support wherein each vial retaining section has a unique position on the support.

65. The assembly of claim 64, wherein the location specific couplings are arrays of pins on and holes in the support and vial retaining sections which align only when the sections are properly positioned with respect to the support.

66. A liquid delivery system useful for dispensing solvents to a reaction grid system having an array of reaction vessels mounted therein, the solvent delivery system comprising:

a manifold with a plurality of valves arranged therein in an array corresponding to the array of reaction tubes;

an arrangement for delivering solvents to the manifold for release by the valves;

an arrangement for opening a plurality of the valves simultaneously;
and

an array of probes corresponding to the array of valves wherein each individual probe is connected to a specific valve for delivering solvent to one reaction vessel.

67. The liquid delivery system of claim 66, wherein the valves are operated by a pneumatic system in which each valve is connected to a separate link which is in turn connected to a common link with the common link being moved by a piston driven by a pneumatic cylinder.

68. The liquid delivery system of claim 67, wherein one-half of the valves are operated by a pneumatic cylinder located on one side of the manifold and the other half of the valves are operated by a pneumatic cylinder on the other side of the manifold.

69. The liquid delivery system of claim 66 further including an evacuation system for applying a partial vacuum to fluid collection members disposed proximate the reaction grid for withdrawing solvents dispensed by the solvent delivery system from the reaction vessels, the evacuation system including the vacuum pump.

70. The liquid delivery system of claim 69 further including a programmable logic controller for activating the system to deliver solvents and for activating the vacuum pump to remove waste solvents from the system.

71. The liquid delivery system of claim 67 further including an elevator connected to the manifold for raising and lowering the manifold with respect to the reaction grid.

72. The liquid delivery system of claim 67 further including pumps for delivering solvent from reservoirs to the manifold.

73. The liquid delivery system of claim 72 further including a programmable logic controller connected to the elevator and solvent pumps for lowering the manifold to insert the probes into the reaction vessels; the controller being connected to the solvent pumps for activating the solvent pumps to pump solvent into the reaction vessels when the probes are in the reaction vessels and for shutting off the solvent pumps and raising the manifold after the solvent has been dispensed.

- 40 -

74. The liquid delivery system of claim 72 further including an elevator for raising and lowering the manifold.

75. An assembly comprising the solvent delivery system of claim 66 and further comprising:

a manifold valve block associated with the reaction grid system, the manifold valve block including a channel block detachably connected thereto for removing waste solvent from the system after the solvent has flowed through each of the reaction vessels.

76. An assembly comprising the solvent delivery system of claim 66 and further comprising:

a manifold valve block associated with the reaction grid system for supporting the reaction vessels and a cleavage block detachably secured to the valve manifold block, the cleavage block having an array of vials therein corresponding in location to the array of reaction vessels wherein reaction products in solutions within the reaction vessels are dispensed to the vials upon opening valves in the valve manifold block.

77. A heating and cooling unit for heating the contents of an array of reaction vessels mounted on a reaction grid, wherein the unit comprises:

a first heating block with an array of holes therein corresponding to the array of reaction vessels wherein the reaction vessels are received through the holes;

a second block with an array of holes therein corresponding to the array of holes in the first block also for receiving the reaction vessels therethrough; and

an electric heating pad sandwiched between the first and second blocks, the electric heating pad having an array of holes therein corresponding to the arrays of the first and second heating blocks, the pad

heating the first and second heating blocks to heat the contents of the reaction vessels.

78. The heating and cooling unit further including at least one cooling cavity in the heating blocks.

79. The arrangement of claim 78, wherein the cooling cavity is an indentation in an upper surface of the first block for receiving a cooling medium.

80. The arrangement of claim 79, wherein the cooling medium is dry ice.

81. The arrangement of claim 79, wherein the cooling cavity is a channel which is within the cooling block and receives cooling fluid which circulates through the channel.

82. A process for obtaining reaction products from an array of reaction vessels, the process comprising:

(a) inserting reaction vessels having solid supports therein in a grid having a manifold with an array of valves individually connected to each reaction vessel;

(b) loading the reaction vessels with reagents and solvents at a first site;

(c) simultaneously sealing the reaction vessels;

(d) agitating the reaction vessels to facilitate formation of reaction products within the reaction vessels;

(e) simultaneously delivering a solvent liquid to each of the reaction vessels at a second site to form a suspension;

(f) agitating the reaction vessels while at the second site to facilitate homogenization of the suspension;

- 42 -

(g) simultaneously opening the valves in the manifold and applying a partial vacuum to a drainage collection member to remove waste solvents from the reaction vessels;

(h) repeating steps (b)-(g), as necessary, depending on the number of cycles necessary for the reactions;

(i) substituting a vial retaining member for the drainage member to align an array of vials with the array of reaction vessels to form a cleavage grid;

(j) delivering a cleavage fluid to each of the reaction vessels;

(k) agitating the reaction vessels to facilitate cleavage of reaction products from the solid supports in the reaction vessels;

(l) opening the valves in the cleavage grid to allow the reaction products to drain to the vials while apply a partial vacuum to the cleavage grid to facilitate drawing reaction products from the reaction vessels into the vials.

83. A process for carrying out multiple solid phase chemical synthesis reactions in a matrix format comprising:

providing reaction vessels each having filters proximate male end connections;

connecting the reaction vessels to inlets of a reaction grid;

loading each of said reaction vessels with solid support beads and attaching chemical templates to said solid support beads via linkers;

performing chemical synthesis reactions for the preparation of organic molecules within each of said reaction vessels;

removing fluid from said reaction vessels by connecting said outlet port to a vacuum supply;

washing said support solid support beads with wash solvent and removing said wash solvent through said outlet port;

removing a first rectangular section of the reaction grid from connection with a second rectangular section thereof and connecting said

- 43 -

first rectangular section to a cleavage section, said cleavage section comprising a chamber containing a plurality of vials, each of said vials communicating with an outlet port of said first rectangular section, said cleavage section further comprising an outlet for connecting said chamber to a vacuum supply means; and

cleaving desired organic product from each of said reaction vessels and collecting the organic product within said individual vials.

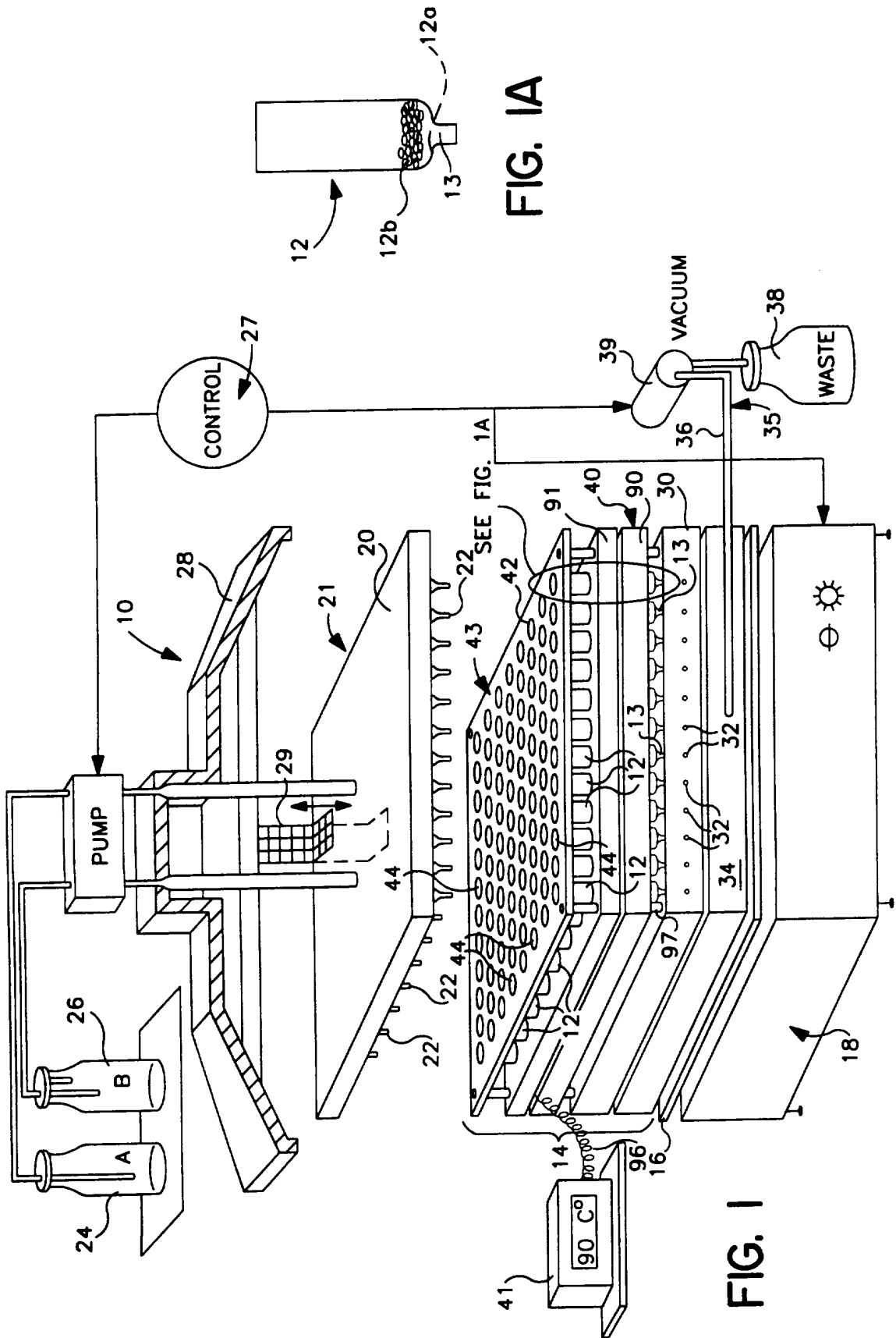

FIG. 1A

FIG. I

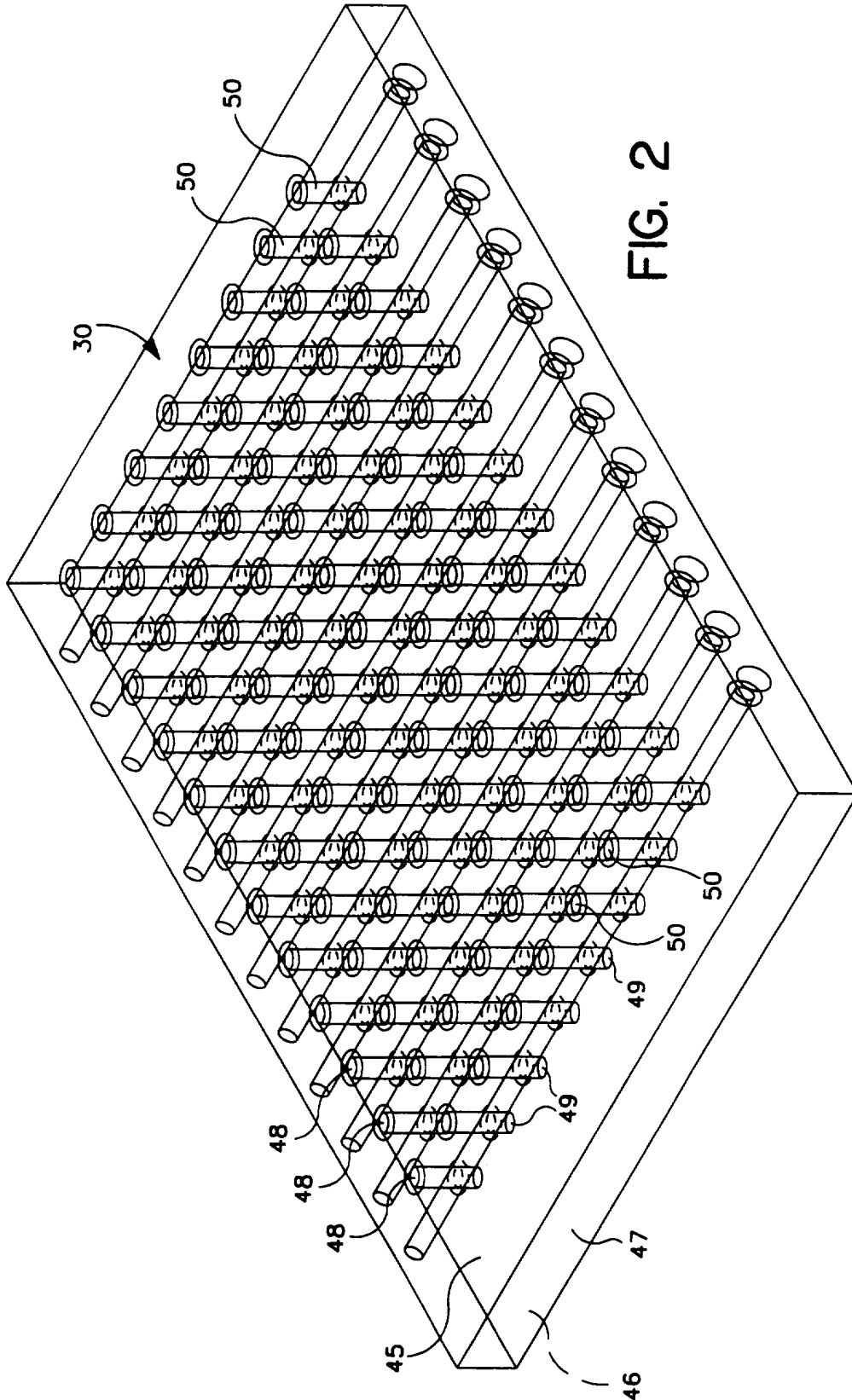

FIG. 2

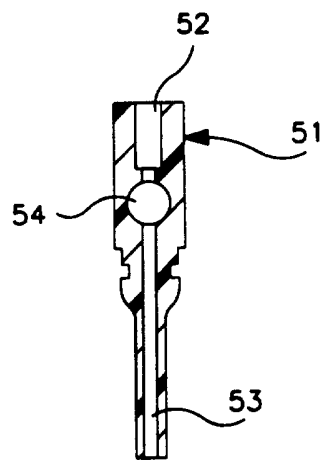

FIG. 3A

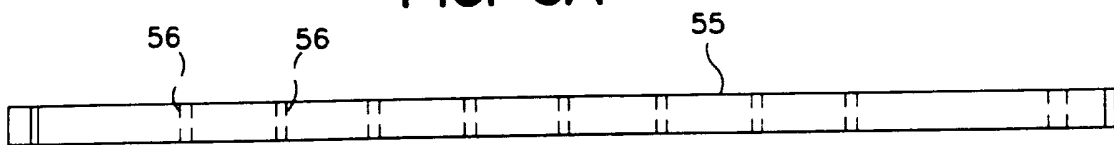

FIG. 3B

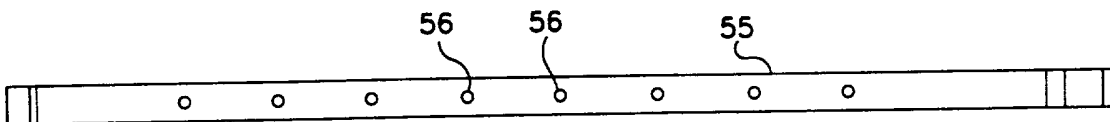

FIG. 3C

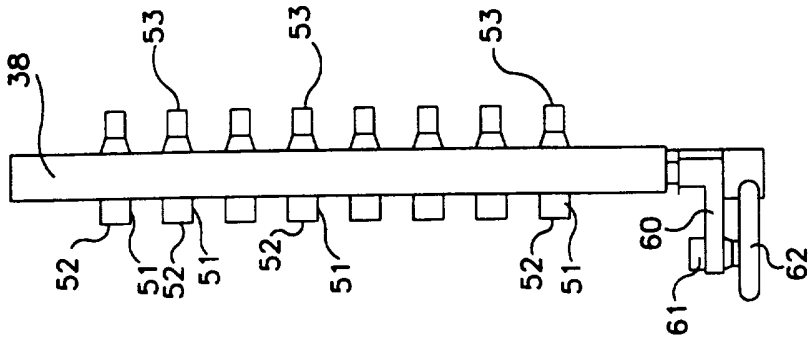

FIG. 6

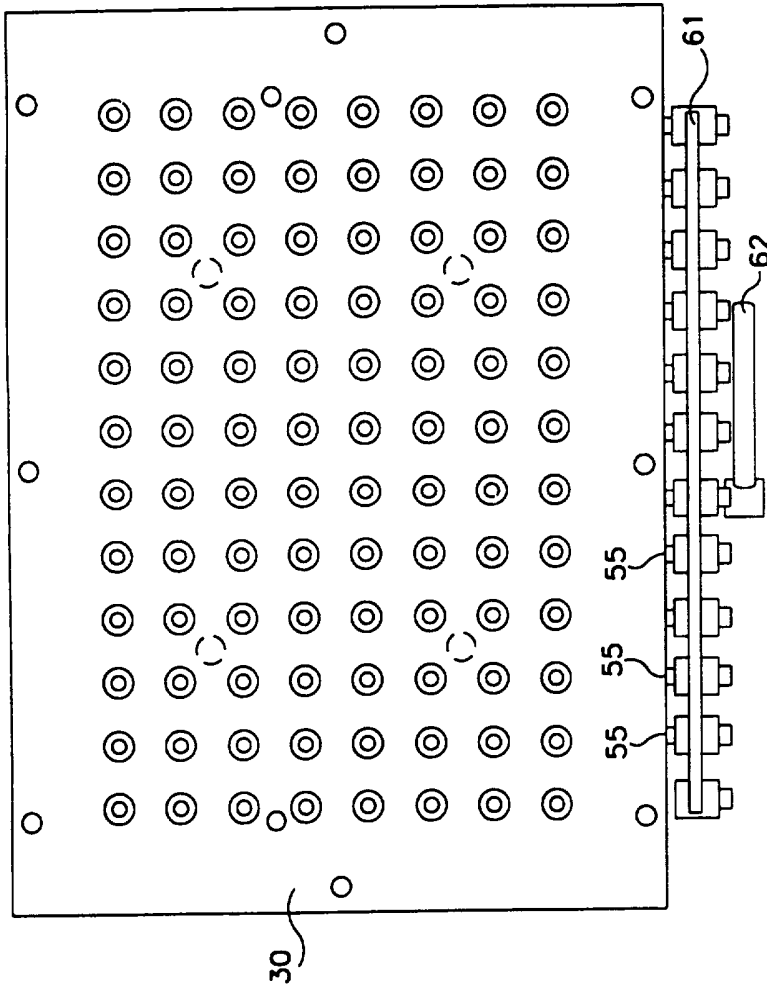

FIG. 4

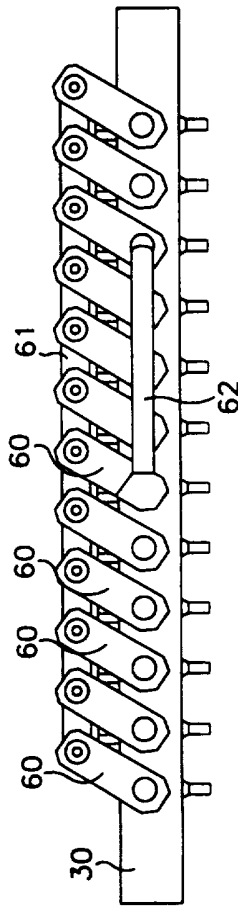

FIG. 5

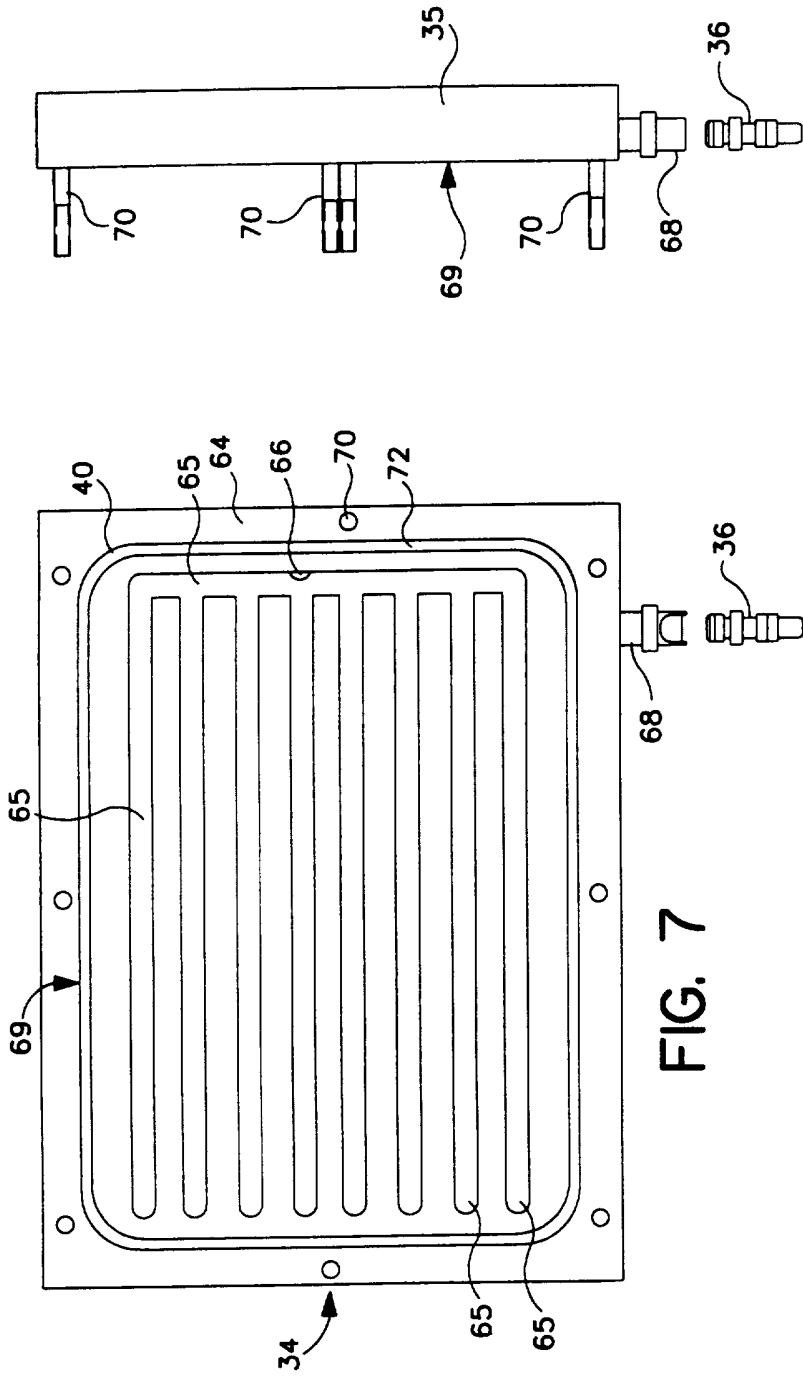

FIG. 9

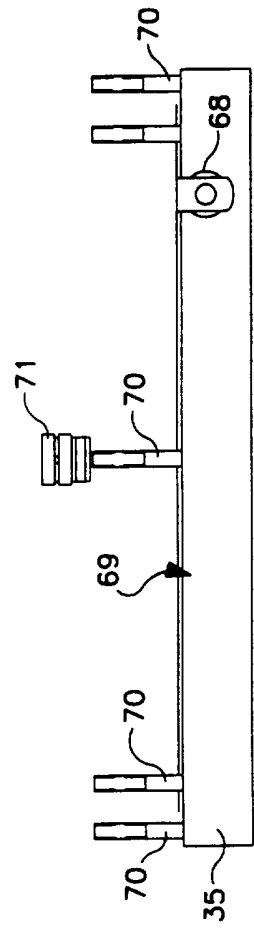

FIG. 8

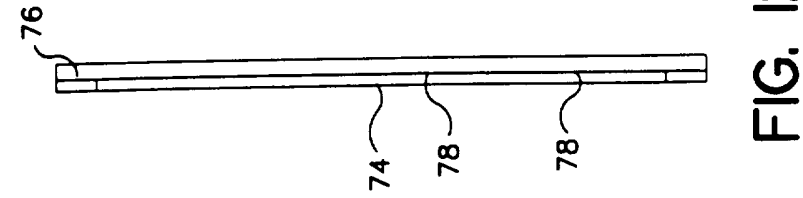

FIG. 10

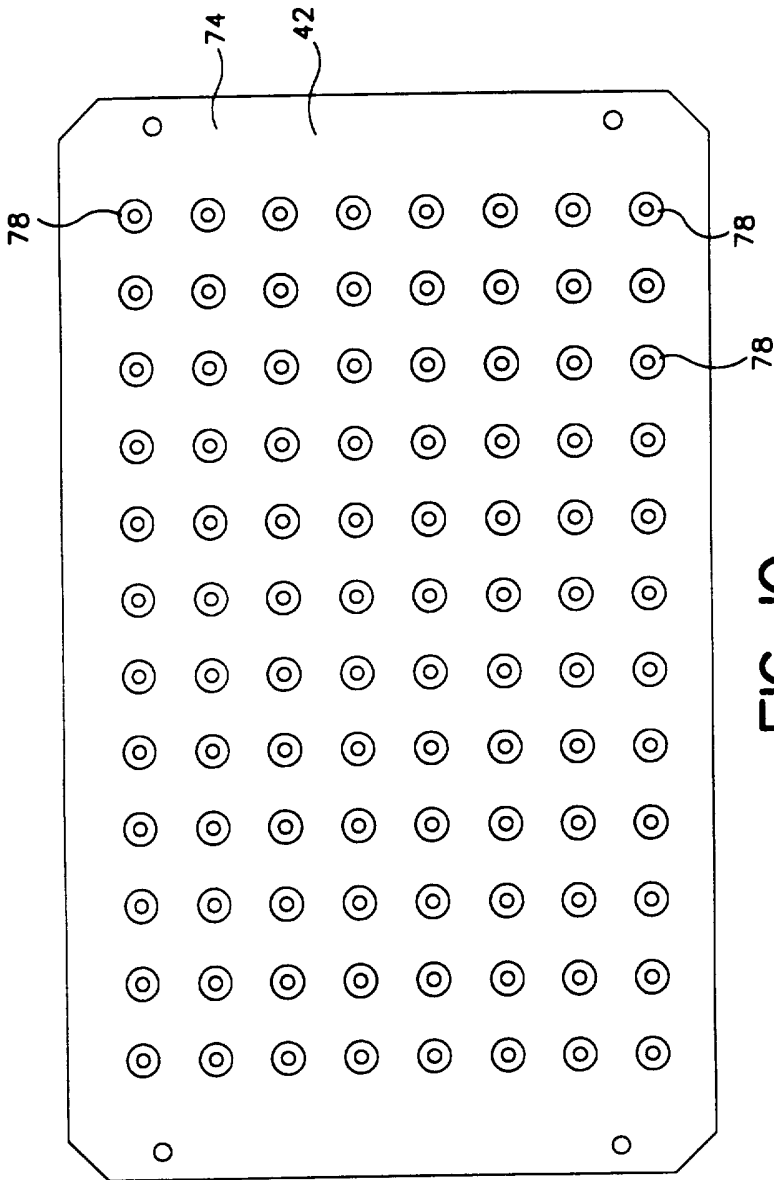

FIG. 11

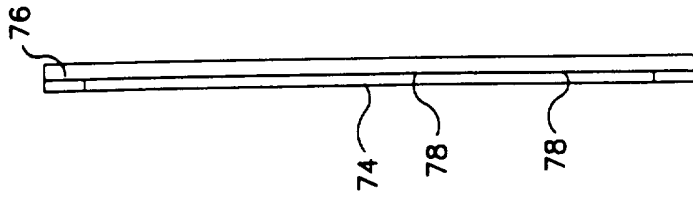

FIG. 12

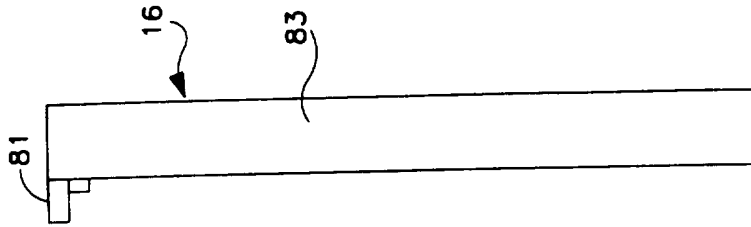

FIG. 15

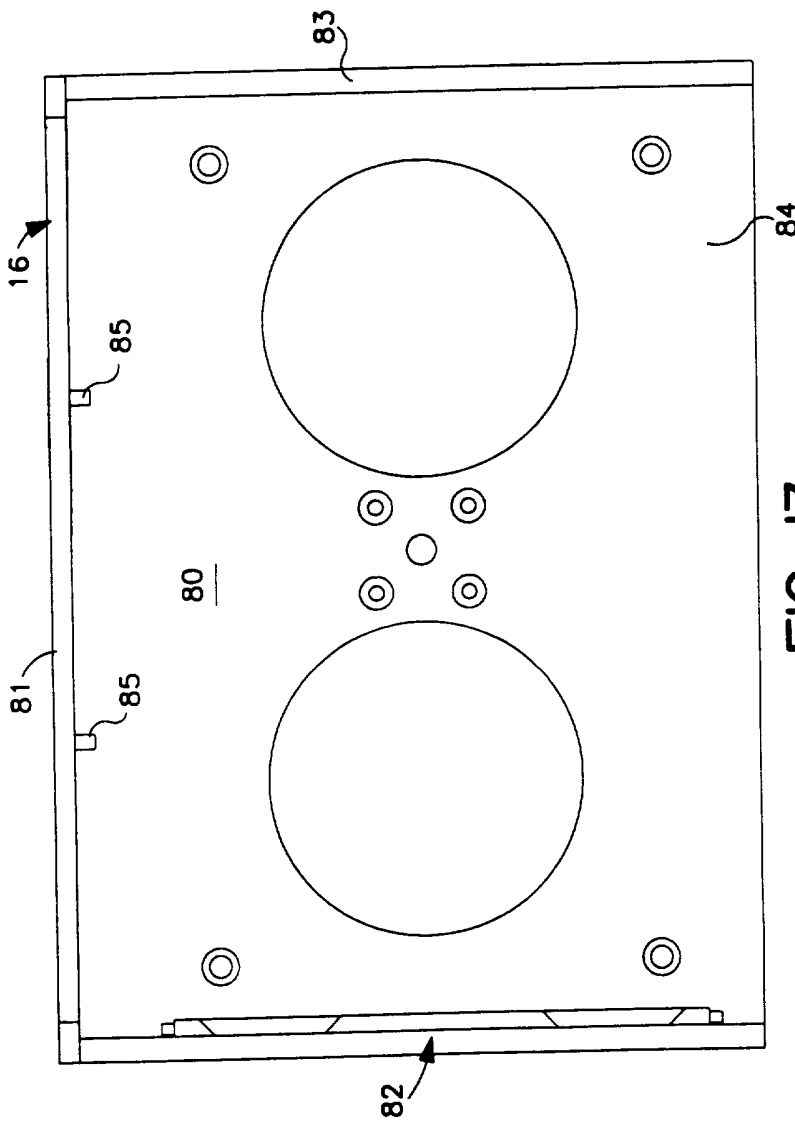

FIG. 13

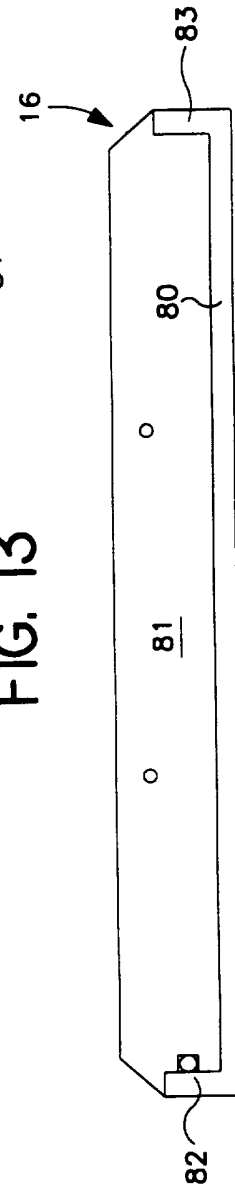

FIG. 14

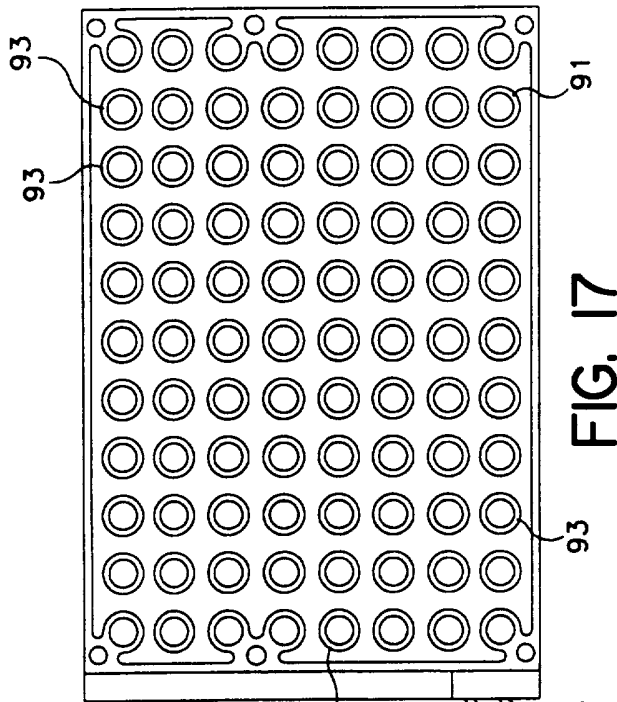

FIG. 17

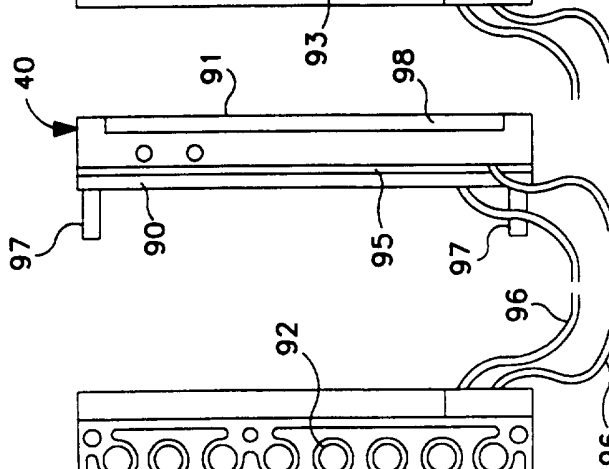

FIG. 18

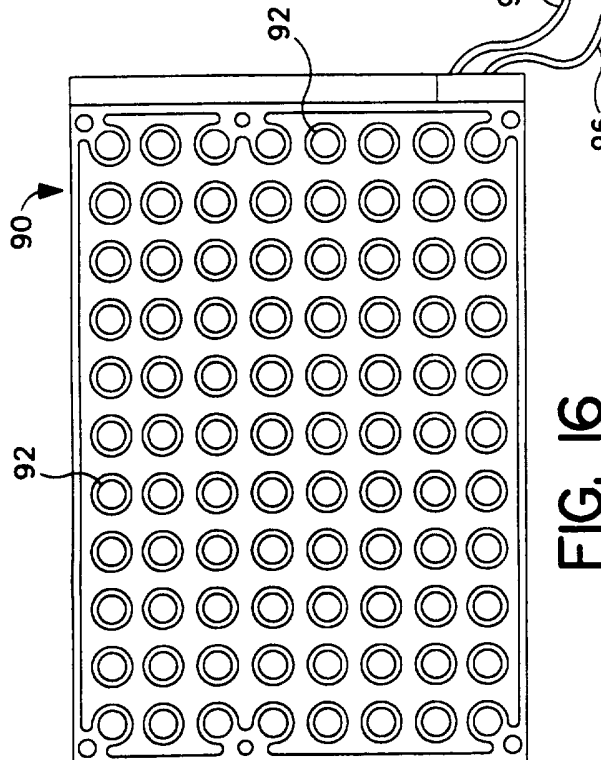

FIG. 16

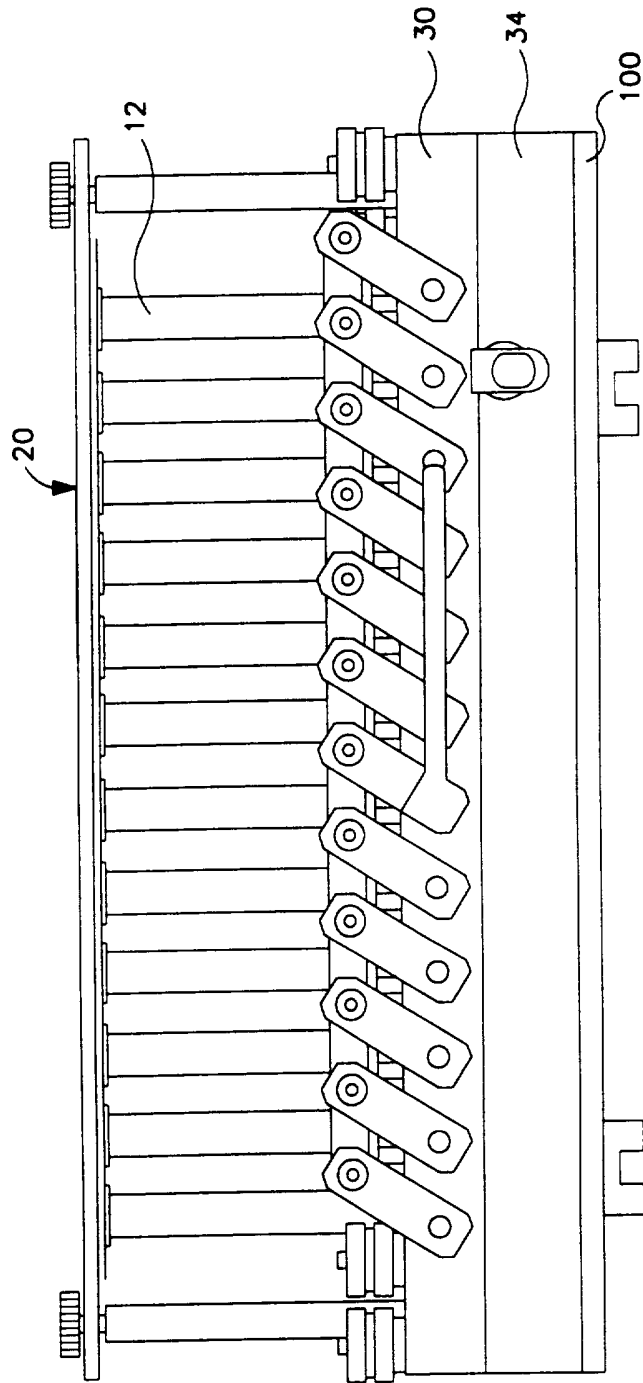

FIG. 19

10/26

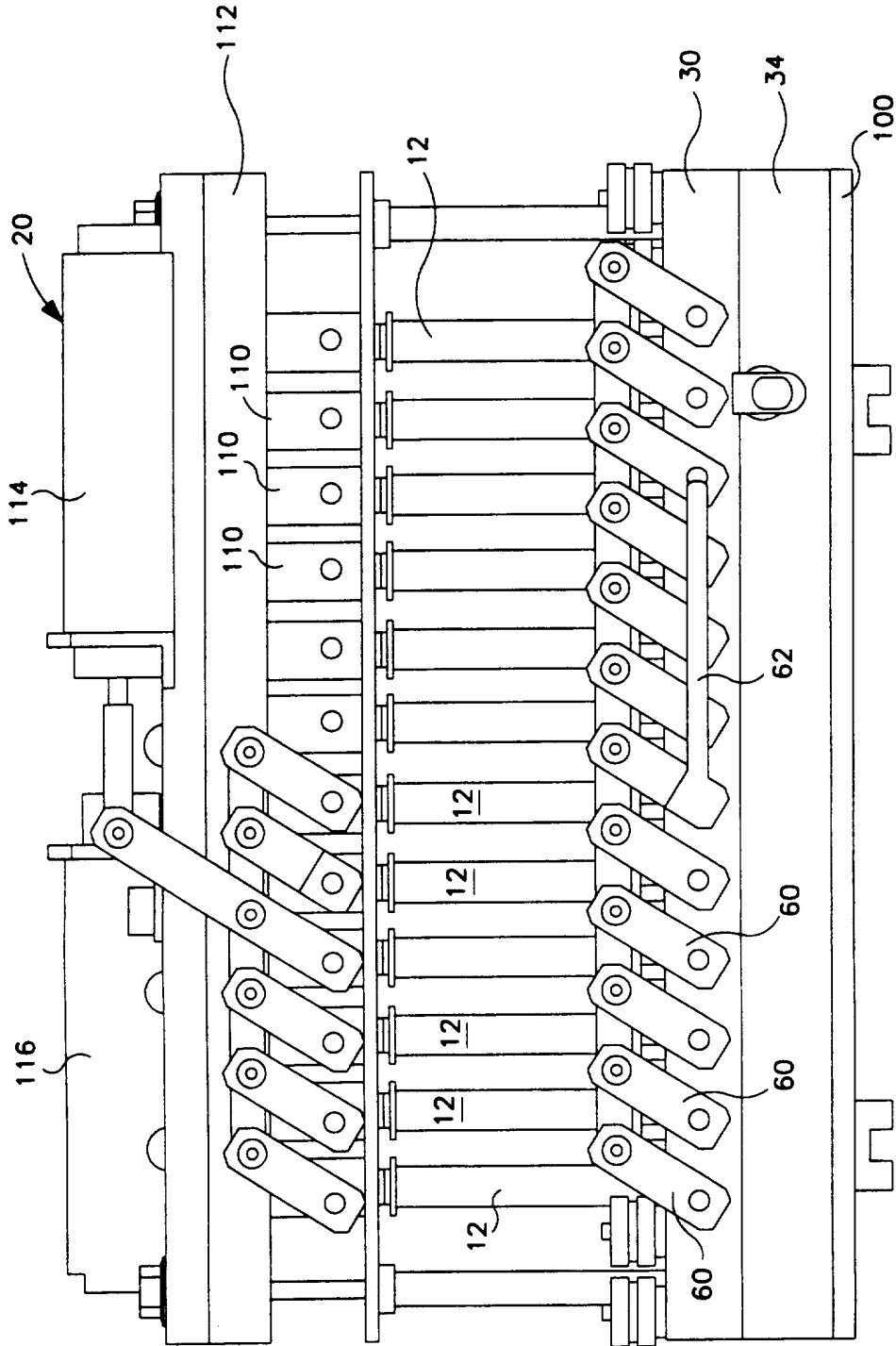

FIG. 20

11/26

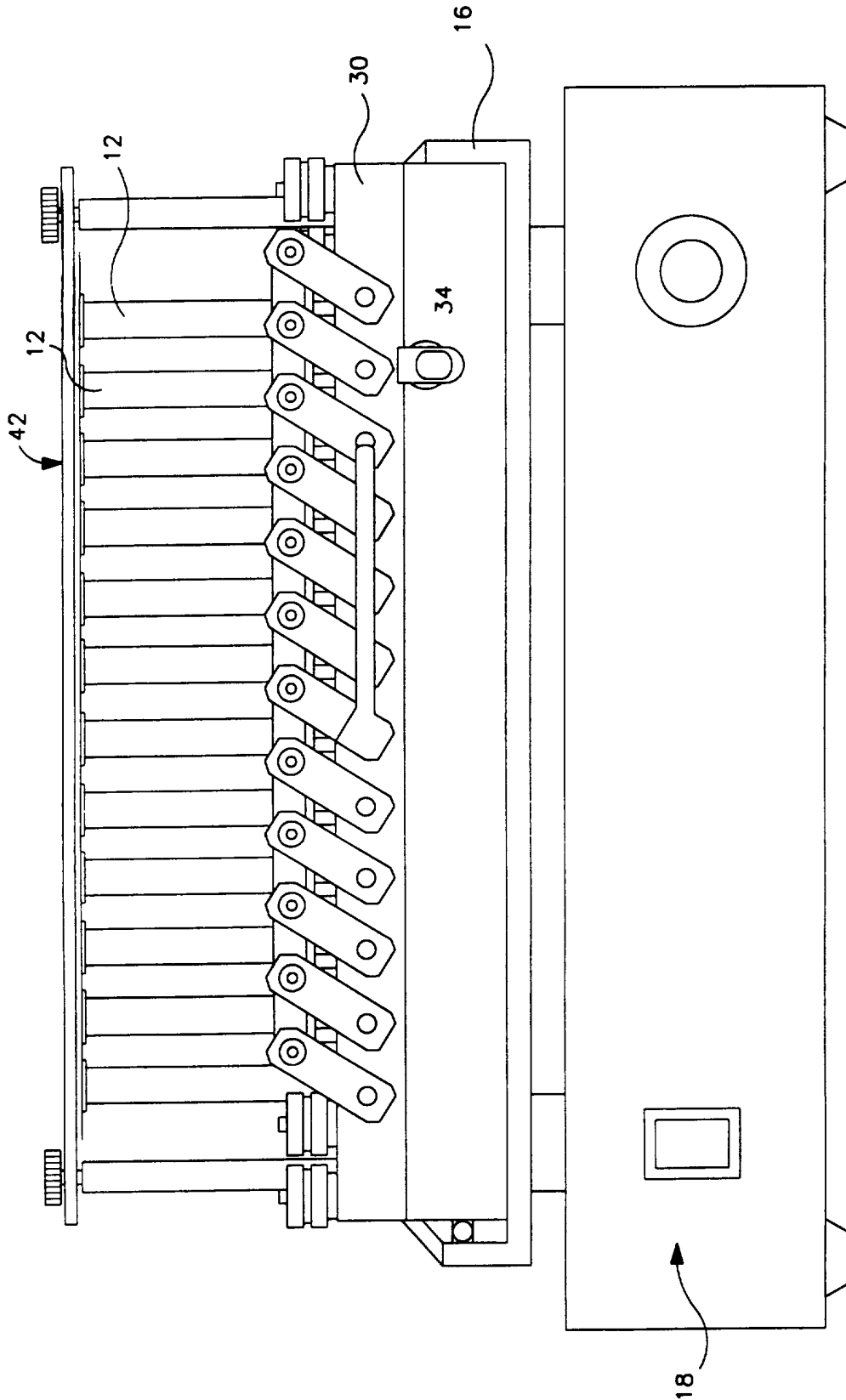

FIG. 21

12/26

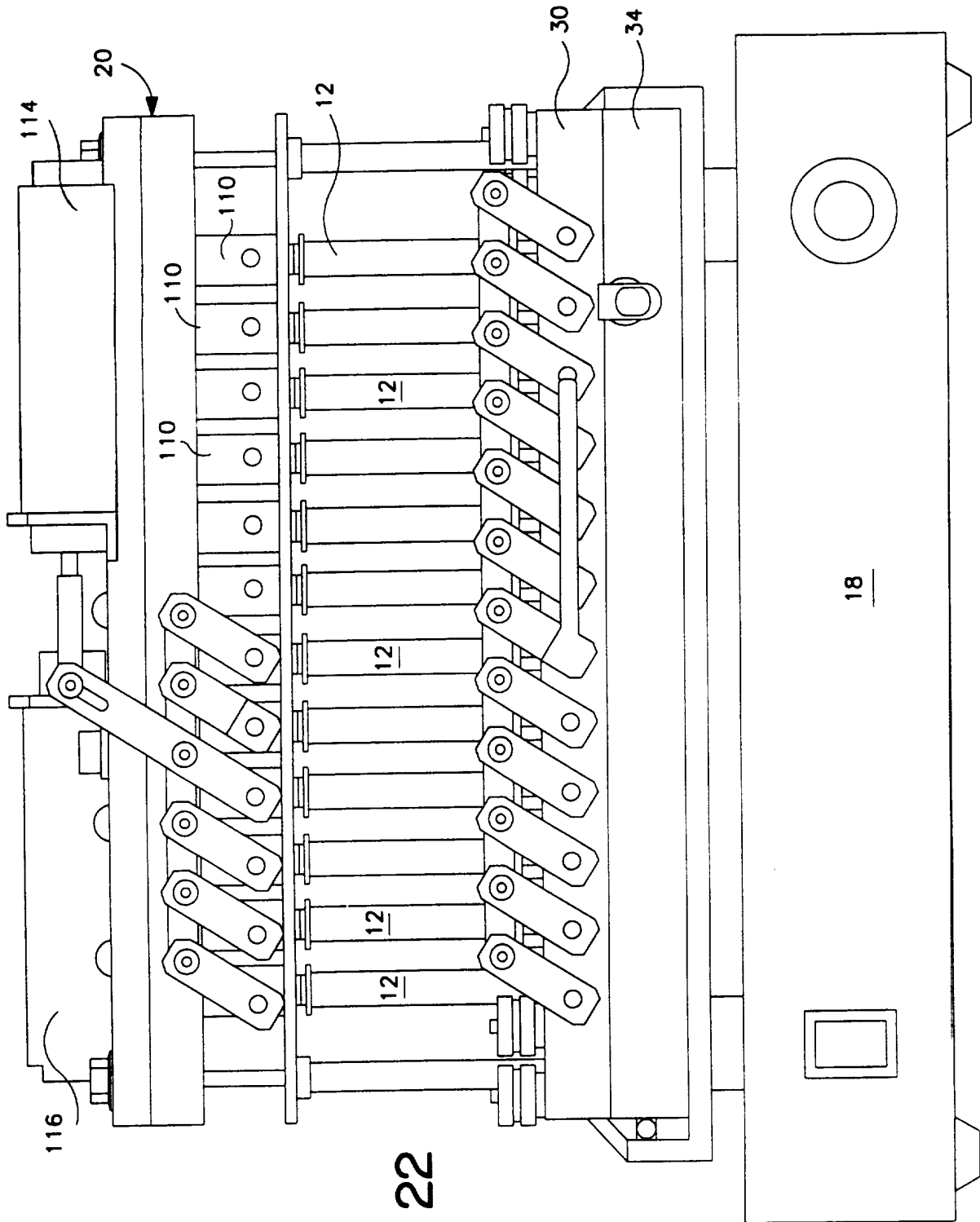

FIG. 22

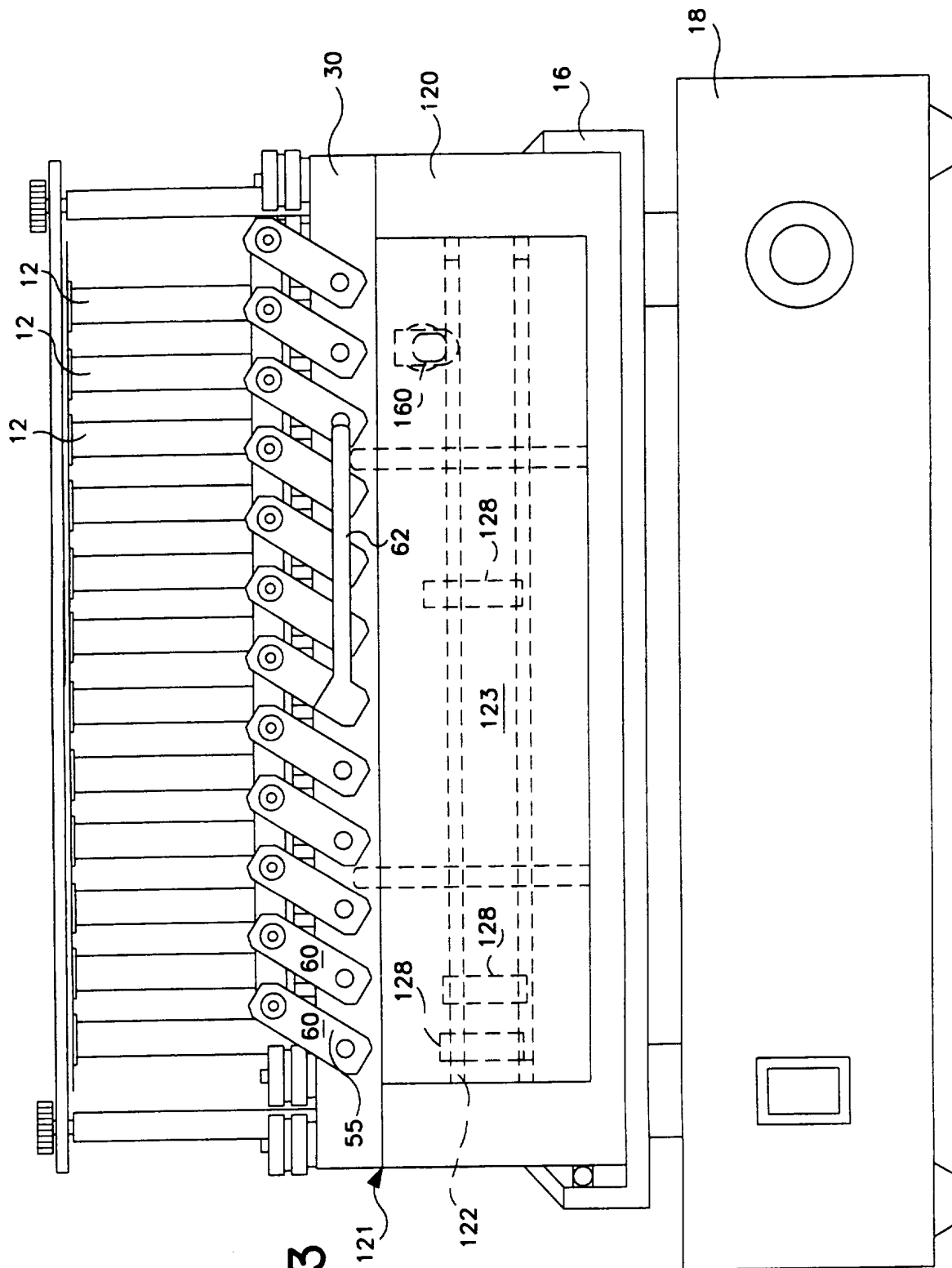

FIG. 23

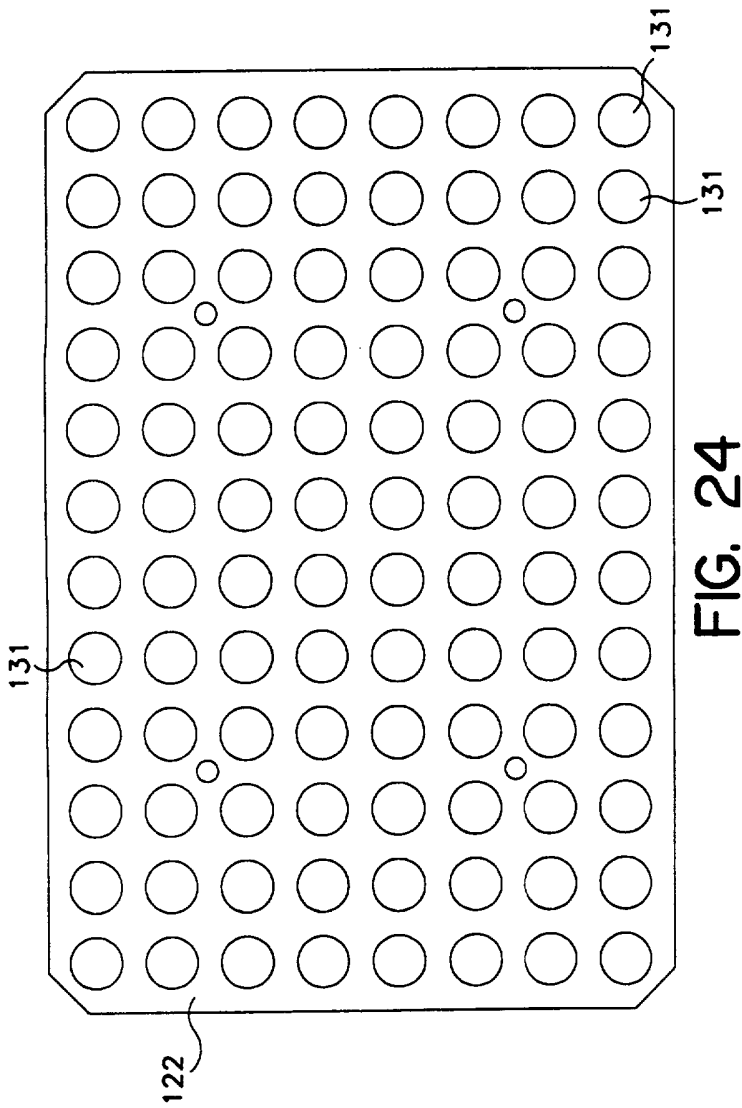

FIG. 24

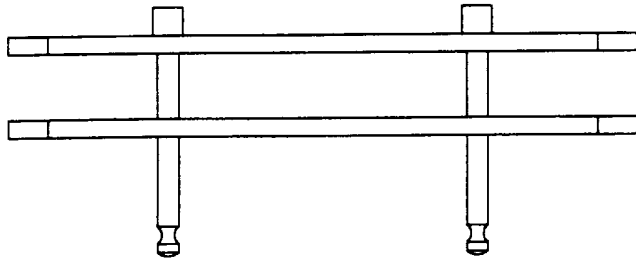

FIG. 26

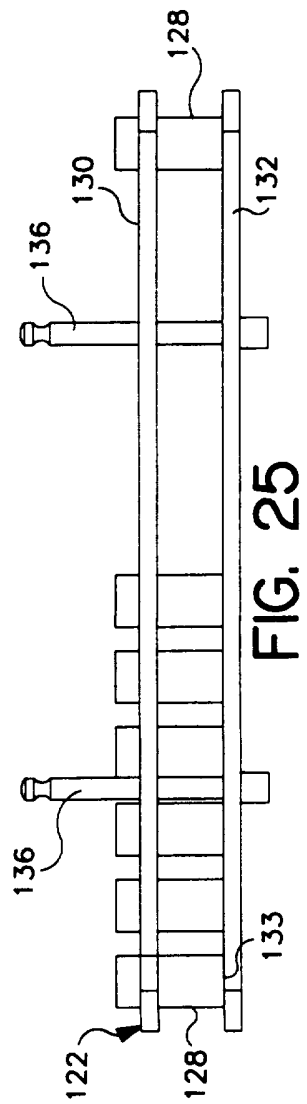

FIG. 25

15/26

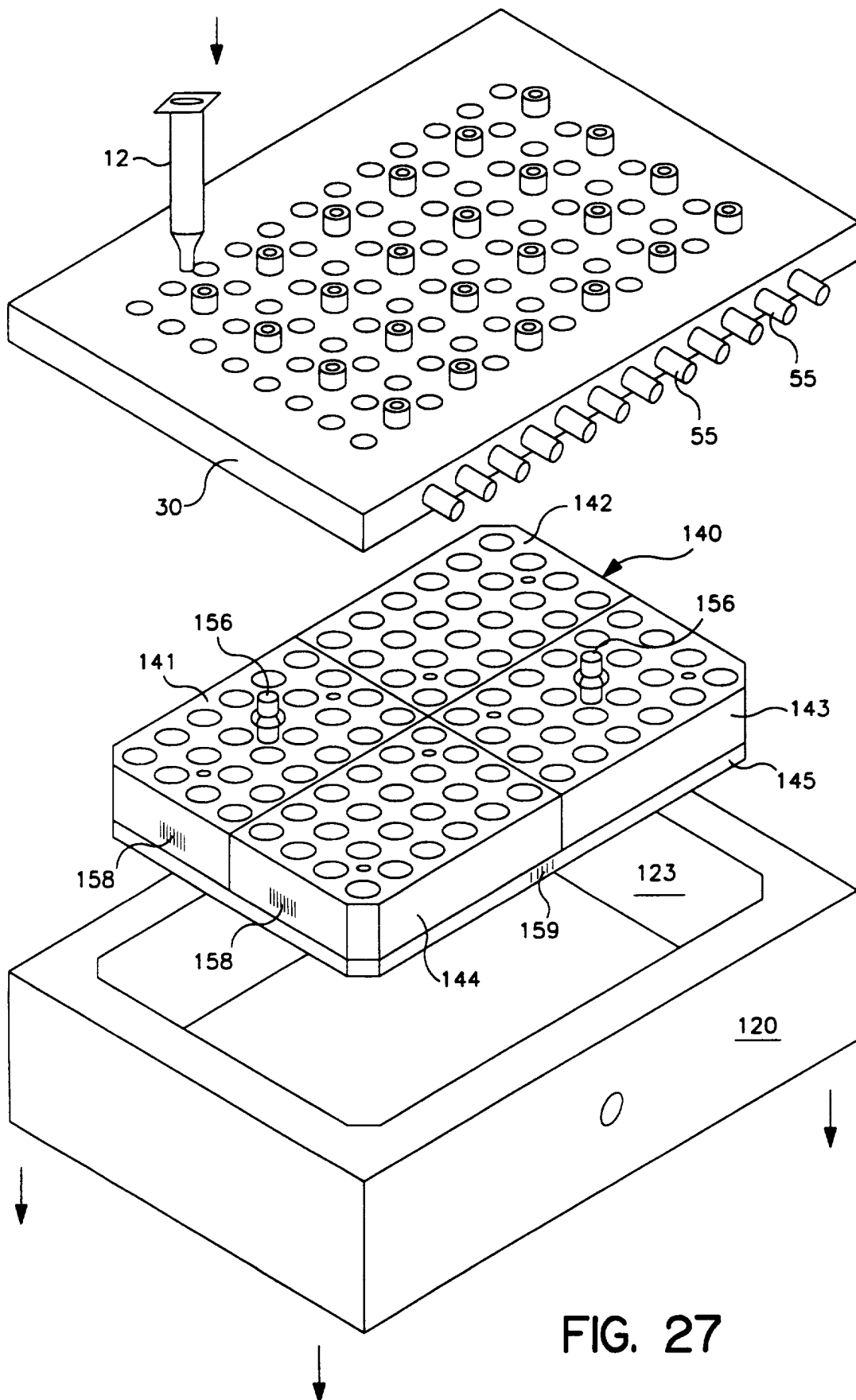
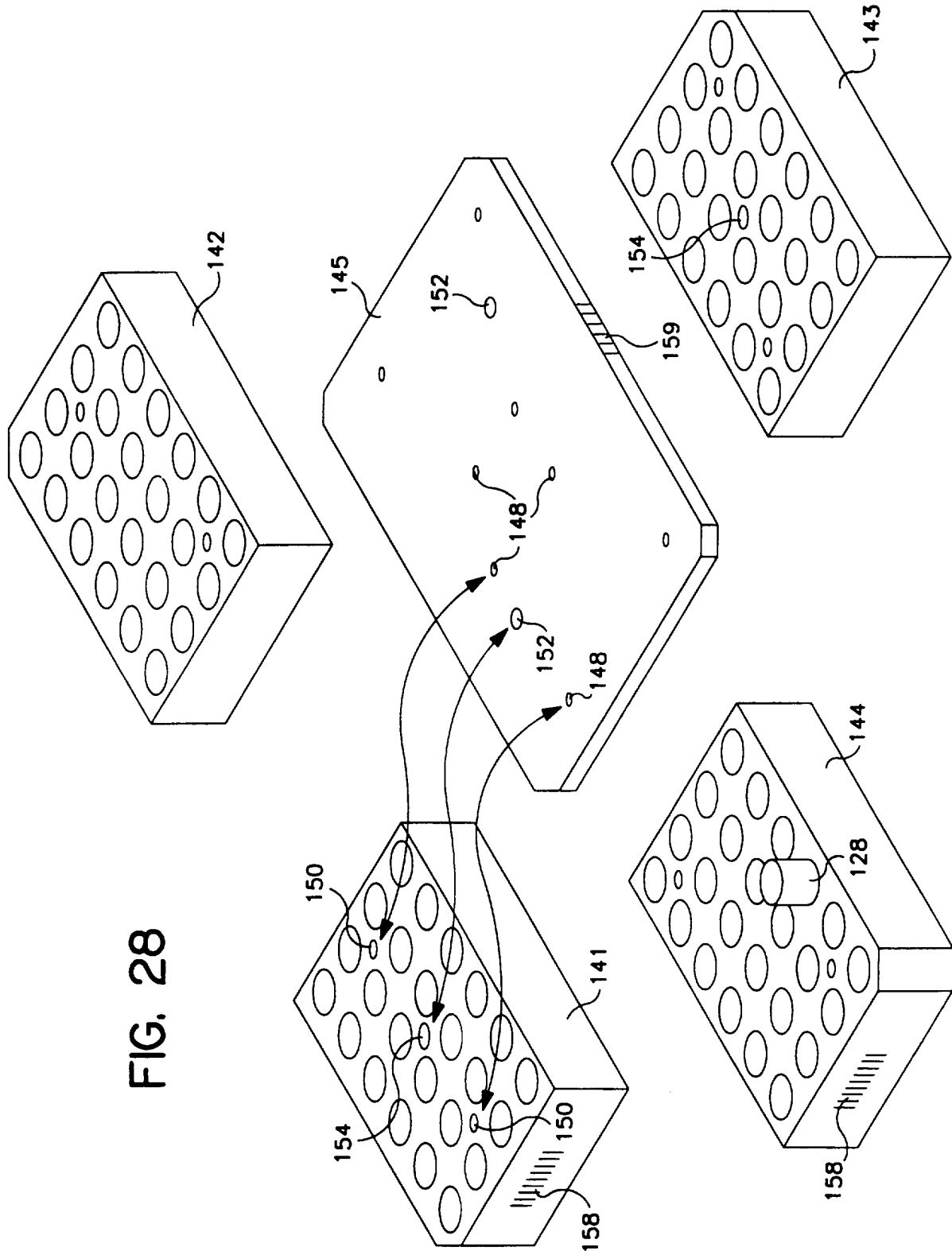

FIG. 27



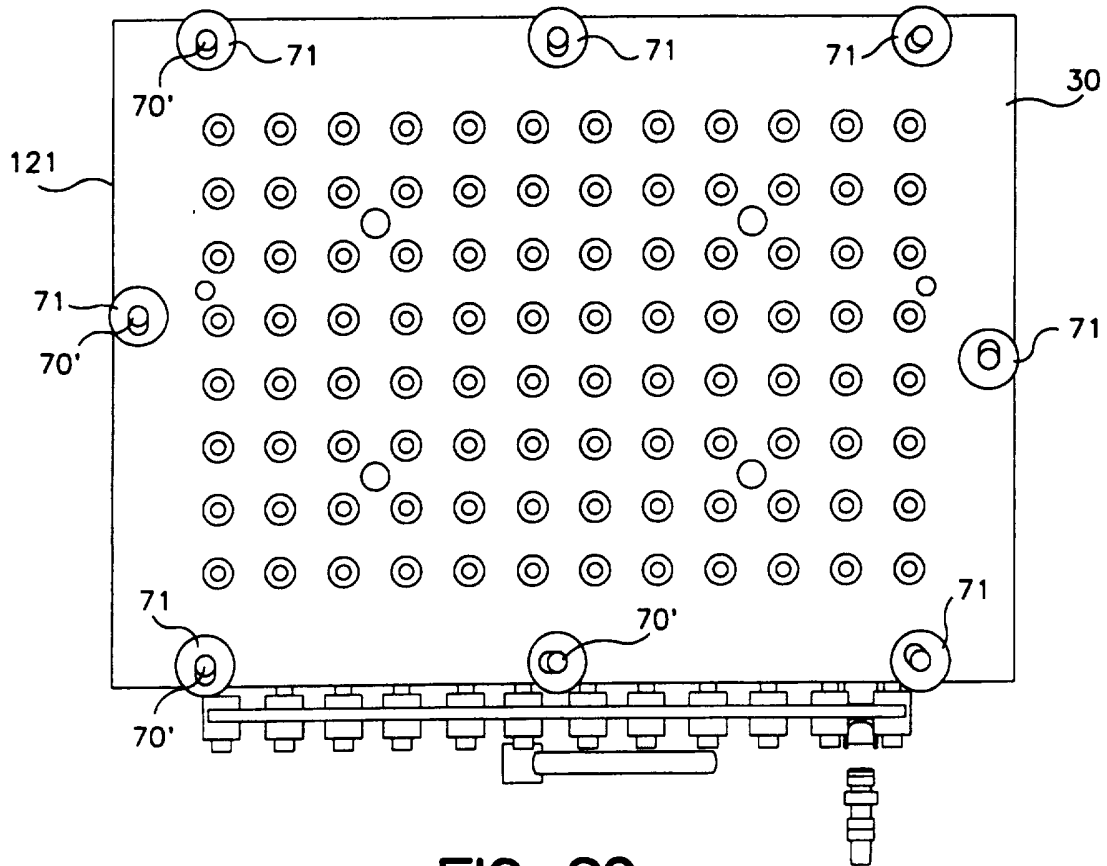

FIG. 29

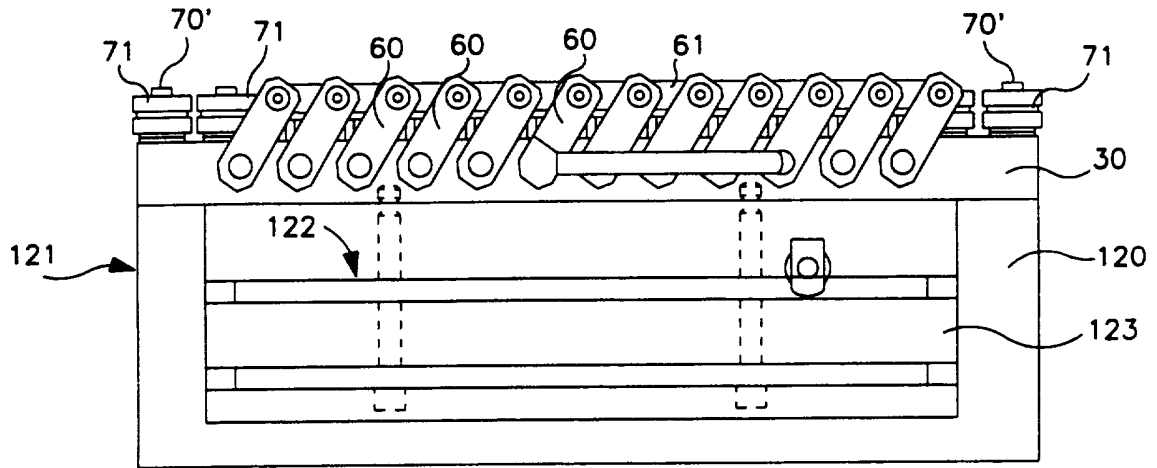

FIG. 30

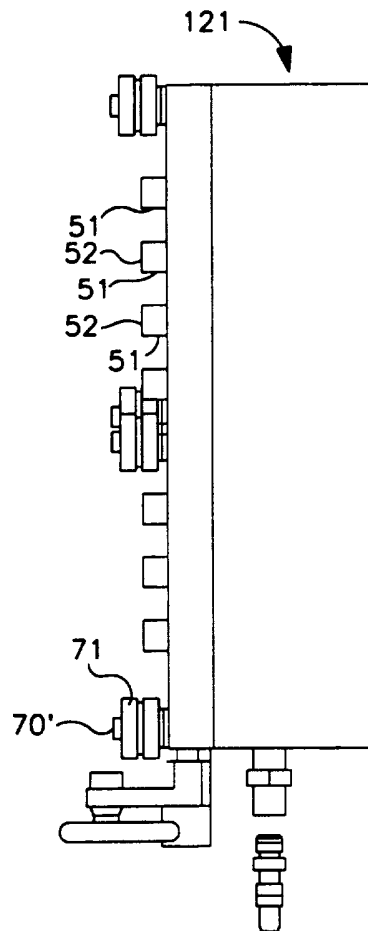

FIG. 31

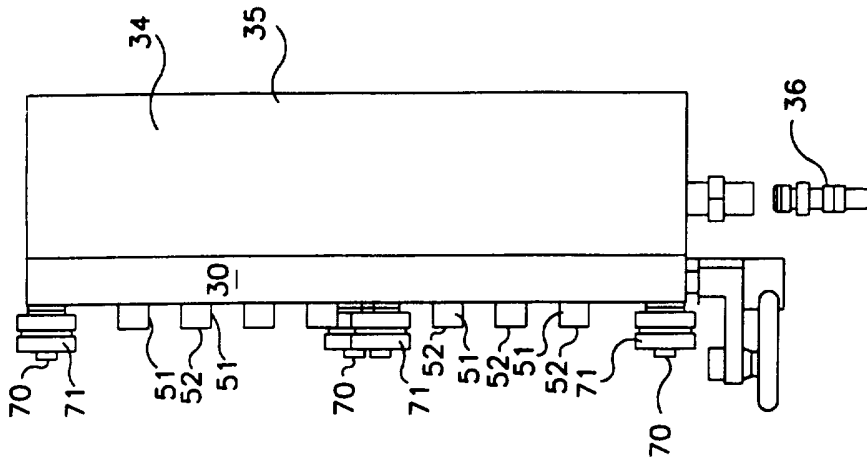

FIG. 34

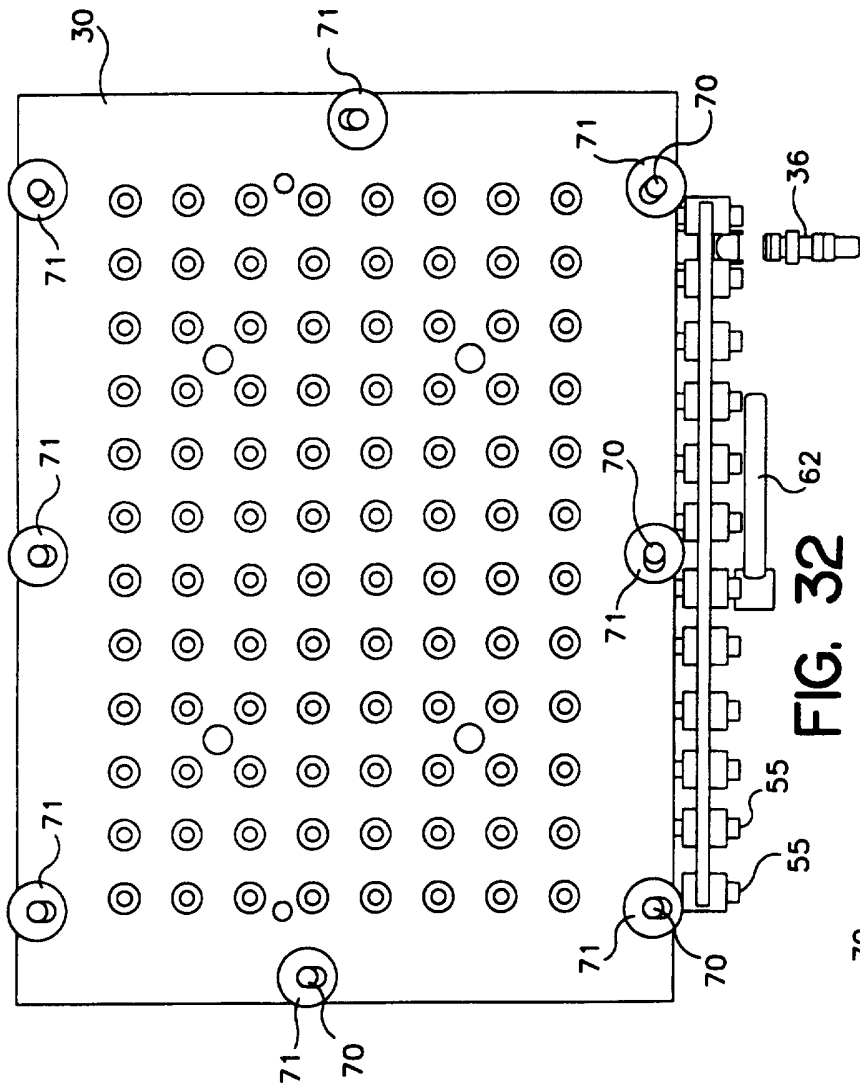

FIG. 32

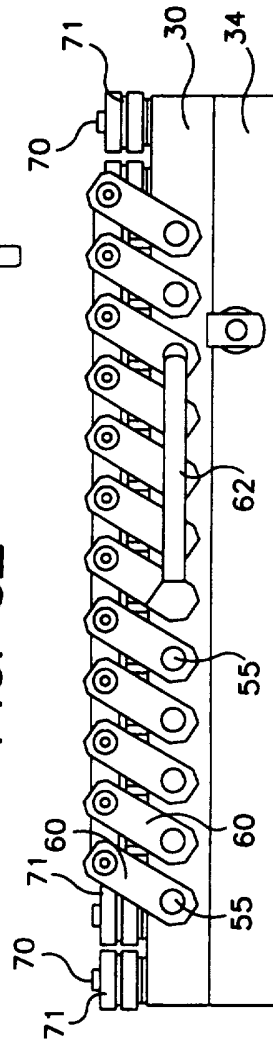

FIG. 33

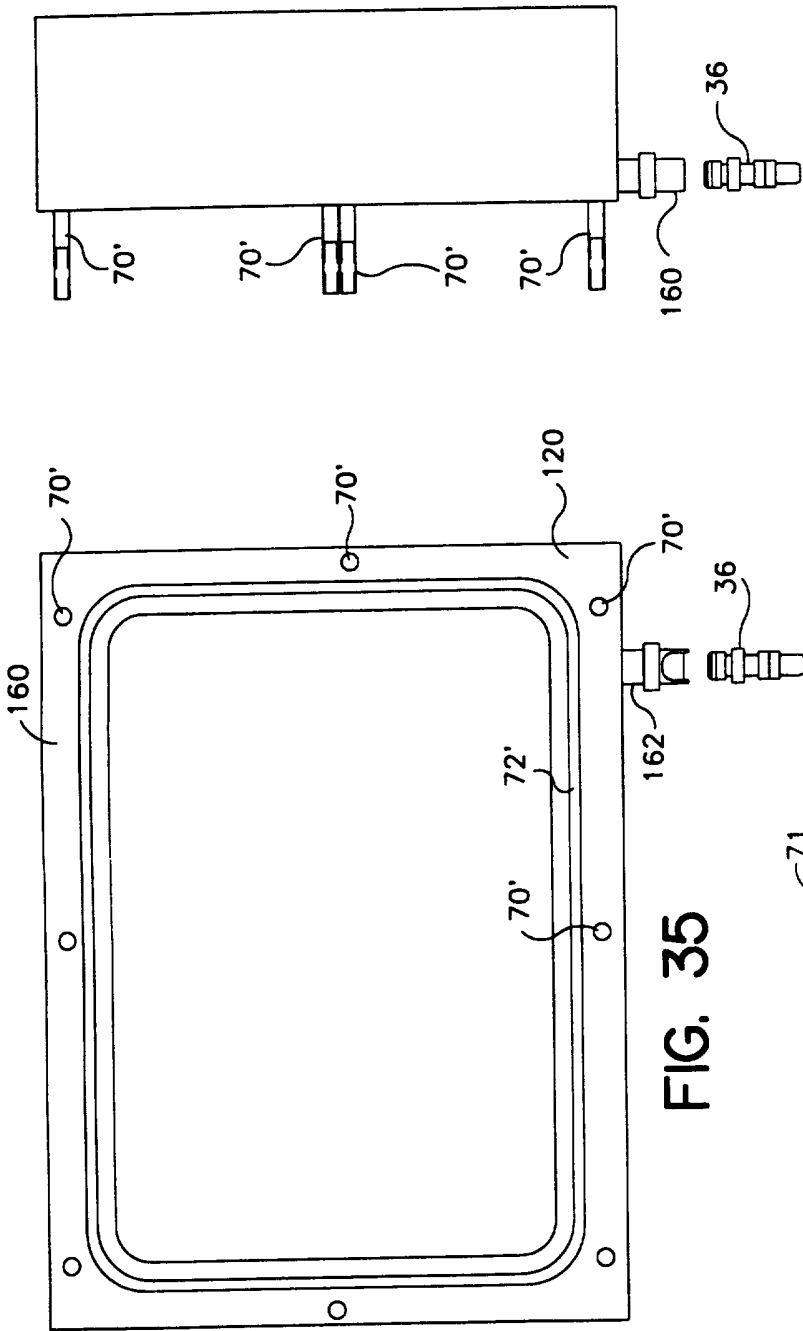

FIG. 35

FIG. 37

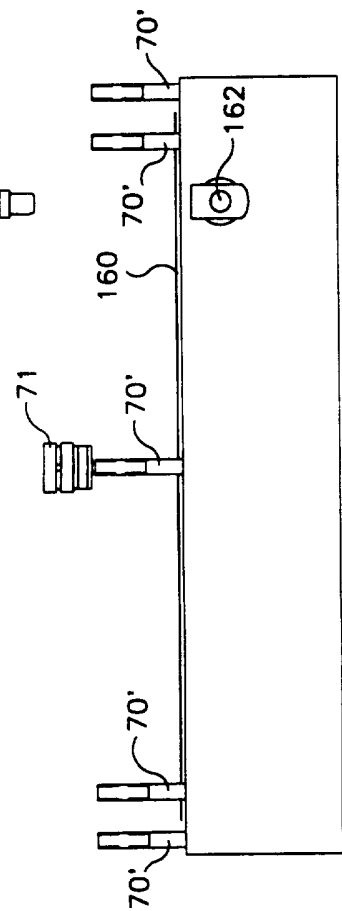

FIG. 36

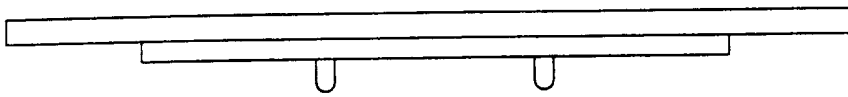

FIG. 40

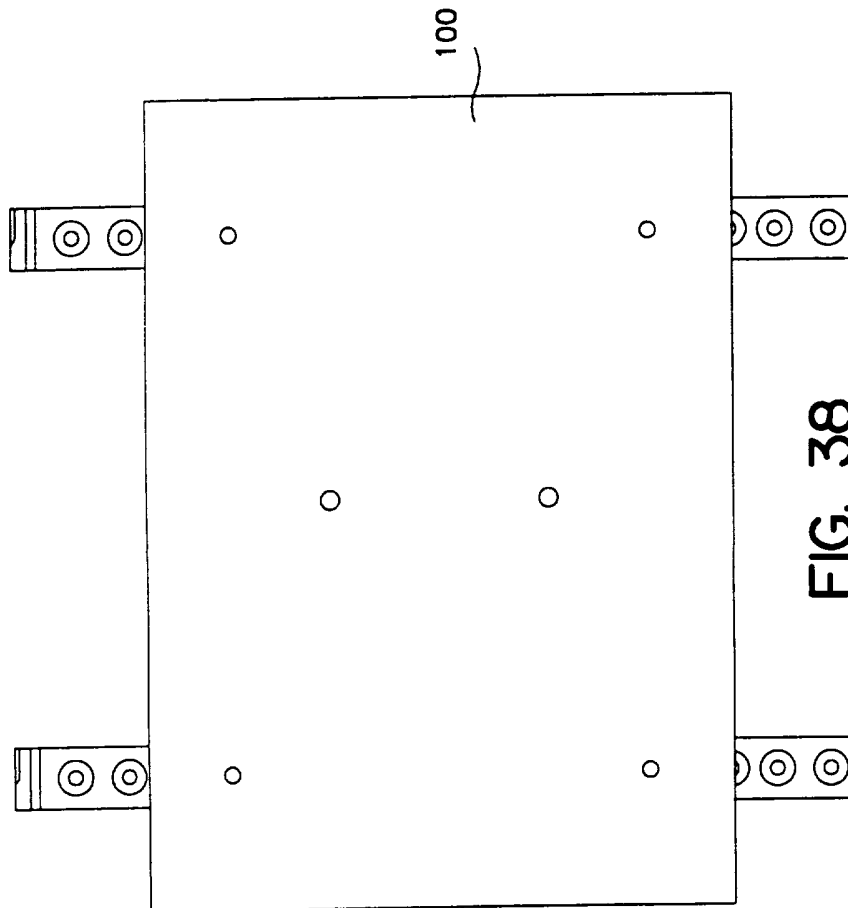

FIG. 38

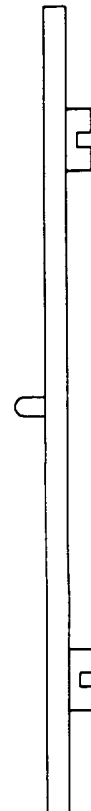

FIG. 39

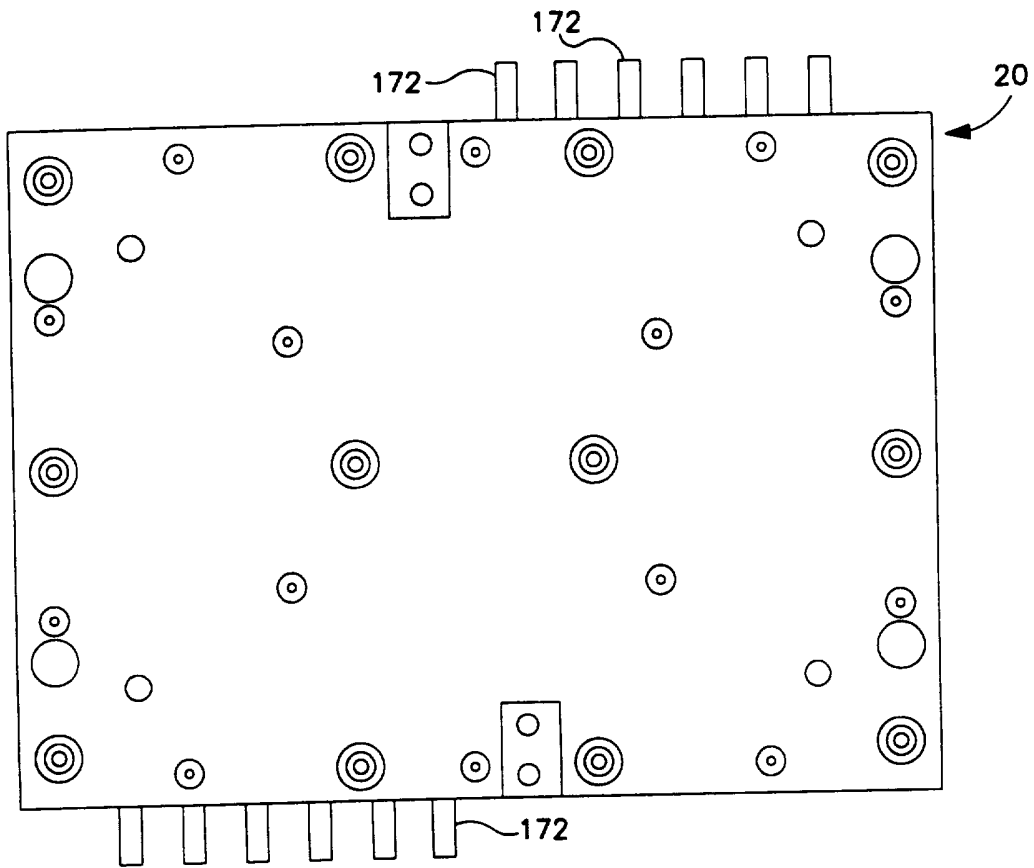

FIG. 41

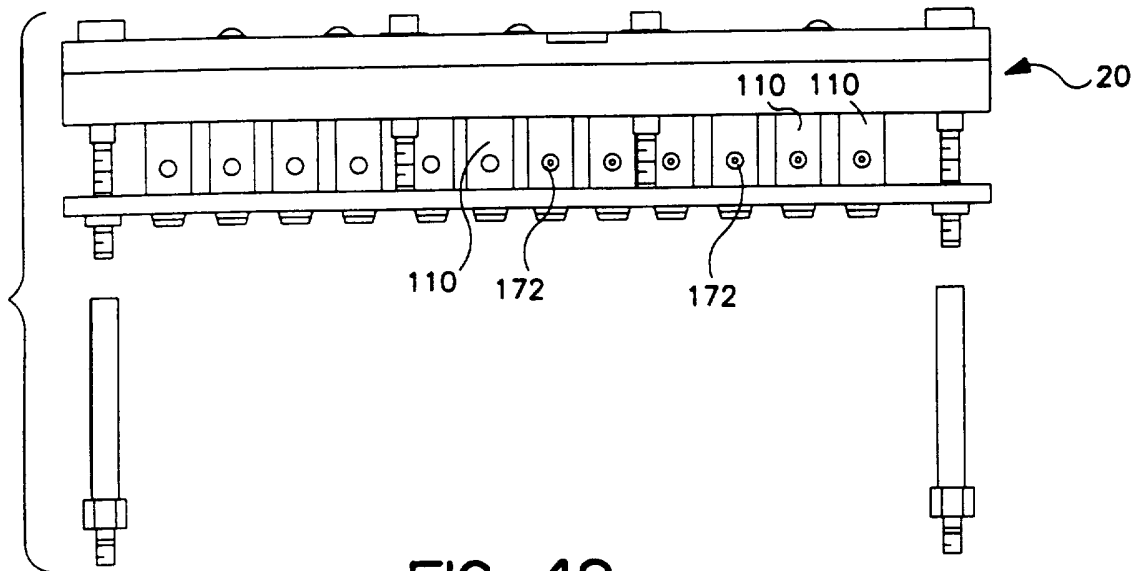

FIG. 42

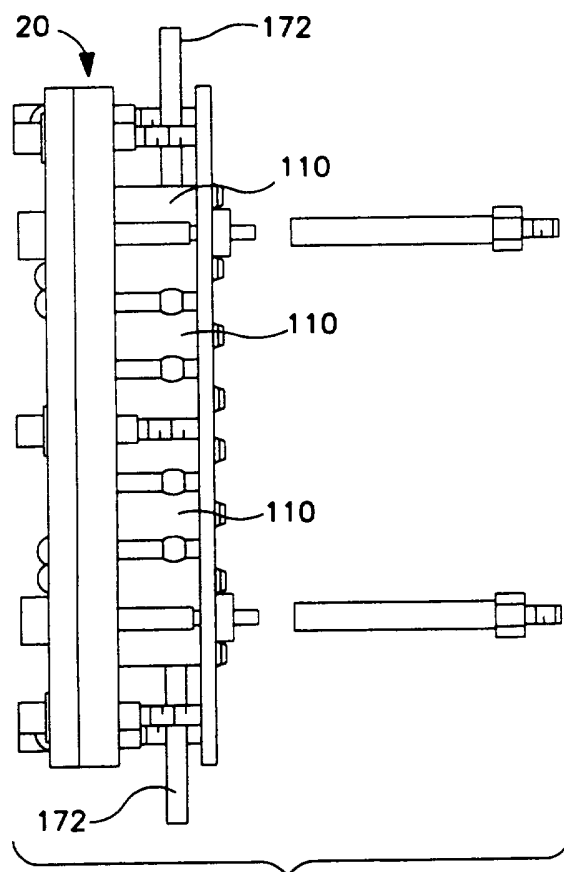

FIG. 43

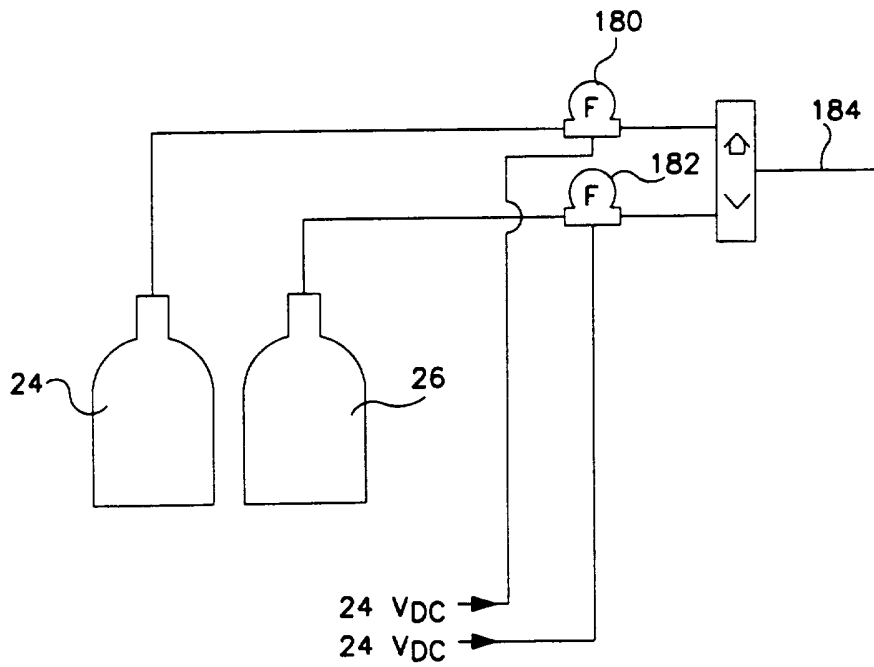

FIG. 44

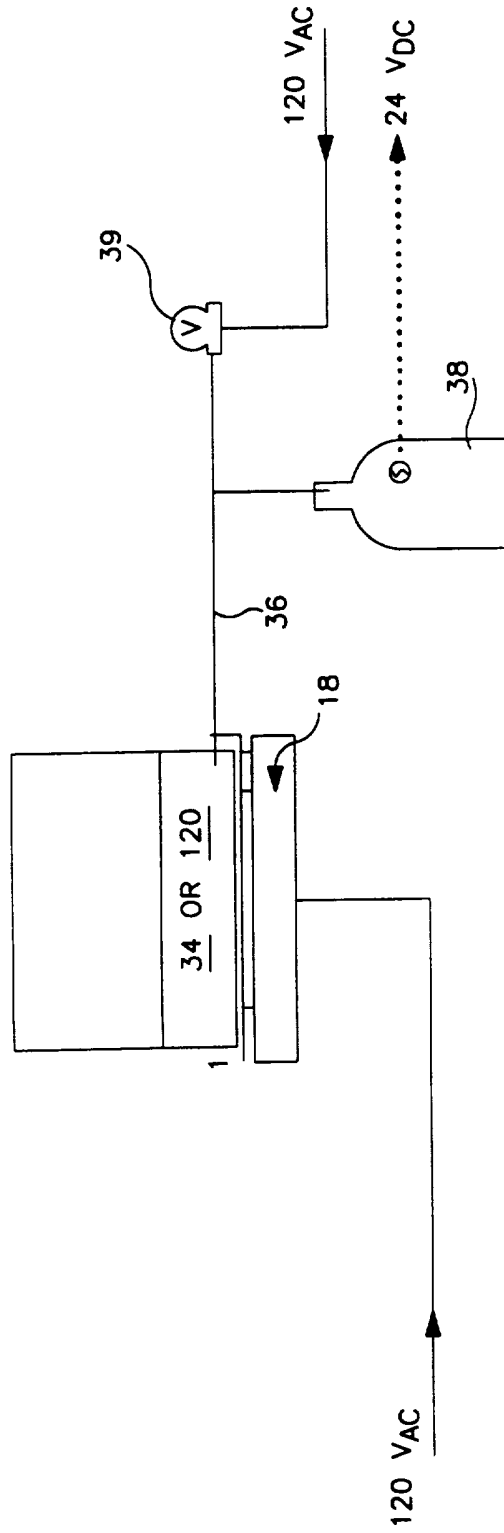

FIG. 45

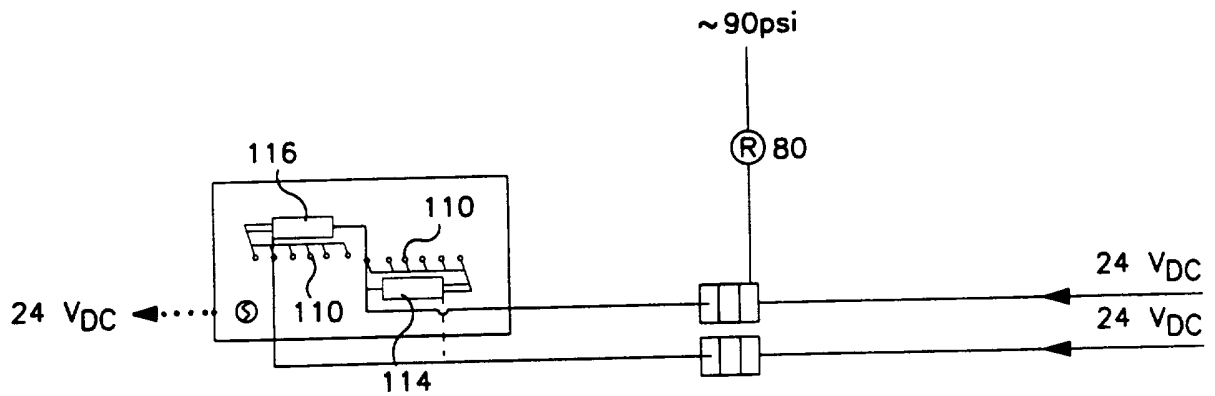

FIG. 46

INTERNATIONAL SEARCH REPORT

national Application No PCT/US 96/15124

A. CLASSIFICATION OF SUBJECT MATTER IPC 6 B01J19/00
According to International Patent Classification (IPC) or to both national classification and IPC
B. FIELDS SEARCHED Minimum documentation searched (classification system followed by classification symbols) IPC 6 B01J B01L
Documentation searched other than minimum documentation to the extent that such documents are included in the fields searched
Electronic data base consulted during the international search (name of data base and, where practical, search terms used)

C. DOCUMENTS CONSIDERED TO BE RELEVANT		
Category *	Citation of document, with indication, where appropriate, of the relevant passages	Relevant to claim No.
	-/--	

Further documents are listed in the continuation of box C.
 Patent family members are listed in annex.

- | | |
|--|---|
| * Special categories of cited documents :
A document defining the general state of the art which is not considered to be of particular relevance
E earlier document but published on or after the international filing date
L document which may throw doubts on priority claim(s) or which is cited to establish the publication date of another citation or other special reason (as specified)
O document referring to an oral disclosure, use, exhibition or other means
P document published prior to the international filing date but later than the priority date claimed | *T* later document published after the international filing date or priority date and not in conflict with the application but cited to understand the principle or theory underlying the invention
X document of particular relevance; the claimed invention cannot be considered novel or cannot be considered to involve an inventive step when the document is taken alone
Y document of particular relevance; the claimed invention cannot be considered to involve an inventive step when the document is combined with one or more other such documents, such combination being obvious to a person skilled in the art.
& document member of the same patent family |
|--|---|

Date of the actual completion of the international search <div style="text-align: center; font-size: 1.2em;">9 January 1997</div>	Date of mailing of the international search report <div style="text-align: center; font-size: 1.2em;">22.01.97</div>
Name and mailing address of the ISA European Patent Office, P.B. 5818 Patentlaan 2 NL - 2280 HV Rijswijk Tel. (+31-70) 340-2040, Tx. 31 651 epo nl, Fax (+31-70) 340-3016	Authorized officer <div style="text-align: center; font-size: 1.2em;">Stevnsborg, N</div>

INTERNATIONAL SEARCH REPORT

national Application No
PCT/US 96/15124

C.(Continuation) DOCUMENTS CONSIDERED TO BE RELEVANT		
Category	Citation of document, with indication, where appropriate, of the relevant passages	Relevant to claim No.
X	E.GIRALT & D. ANDREU (EDS.): "Proceedings of the Twenty-First European Peptide Symposium September 2-8 1990 Platja d'Aro Spain" 1991, ESCOM, LEIDEN, NL XP002022349 190790 H. Gausepohl et al.: "A multiple reaction system for automated simultaneous peptide synthesis" see page 206 - page 207	1,2,4
A	---	3,9,10, 13,15, 16,20, 22,23, 25,27, 28,31, 33,36, 38-40, 43,46, 50,53, 57,60
A	DE,A,40 08 085 (ABIMED ANALYSEN-TECHNIK GMBH) 19 September 1991 see the whole document	1,2,4,8, 16,20, 25,33, 34,36, 40,43, 46,47, 50,51, 53,54, 57,66,67
A	WO,A,90 02605 (M.MELDAL ET AL.) 22 March 1990	1-3,9, 10,15, 16,20, 22,23, 27,28, 31,38, 39,43, 44,56, 57,66, 69-71, 73-76,82 82,83
A	see the whole document ---	

	-/--	

INTERNATIONAL SEARCH REPORT

national Application No
PCT/US 96/15124

C.(Continuation) DOCUMENTS CONSIDERED TO BE RELEVANT

Category *	Citation of document, with indication, where appropriate, of the relevant passages	Relevant to claim No.
A	WO,A,94 18226 (UNIVERSITY OF GEORGIA RESEARCH FOUNDATION) 18 August 1994 see the whole document ---	1,2,9, 10,15, 16,20, 22,23, 27,28, 31,38, 39,43, 57,66, 69,70, 72,82,83
A	WO,A,95 11262 (THE BOARD OF TRUSTEES OF THE LELAND STANFORD JUNIOR UNIVERSITY) 27 April 1995 see the whole document ---	1-3,9, 10,13, 14,16, 20,22, 23,27, 28,31, 38,39, 57,66
A	WO,A,95 12608 (AFFYMAX TECHNOLOGIES N.V.) 11 May 1995 see abstract see page 79, line 14 - page 98, line 15 see claims; figures ---	1,4,15, 16,18, 19,41, 42,66, 69,70,73
A	WO,A,91 07504 (KINDCONI PTY. LTD.) 30 May 1991 see the whole document ---	1,3,20, 30,49, 77,78
A	PATENT ABSTRACTS OF JAPAN vol. 8, no. 86 (P-269), 19 April 1984 & JP,A,59 000638 (TOKYO SHIBAURA DENKI K.K.), 5 January 1984, see abstract; figures & DATABASE WPI Section Ch, Week 8913 Derwent Publications Ltd., London, GB; Class B04, AN 89-098131 & JP,A,59 000 638 (TOSHIBA K.K. & DENKA SEIKEN K.K.) , 5 January 1984 see abstract ---	11,12, 21,24, 29,32, 35,45, 48,52
1 A	GB,A,2 177 200 (VEB CARL ZEISS JENA) 14 January 1987 see the whole document --- -/--	1,3,20, 30,49, 77,78

INTERNATIONAL SEARCH REPORT

national Application No
PCT/US 96/15124

C.(Continuation) DOCUMENTS CONSIDERED TO BE RELEVANT		
Category *	Citation of document, with indication, where appropriate, of the relevant passages	Relevant to claim No.
A	EP,A,0 542 422 (GENERAL ATOMICS) 19 May 1993 see abstract see column 5, line 20 - line 32 see figure 1 -----	61-63

INTERNATIONAL SEARCH REPORT

Information on patent family members

International Application No PCT/US 96/15124
--

Patent document cited in search report	Publication date	Patent family member(s)	Publication date
DE-A-4008085	19-09-91	NONE	

WO-A-9002605	22-03-90	AU-A- 4215389	02-04-90

WO-A-9418226	18-08-94	US-A- 5368823	29-11-94
		EP-A- 0683790	29-11-95
		JP-T- 8506813	23-07-96
		US-A- 5541314	30-07-96

WO-A-9511262	27-04-95	US-A- 5472672	05-12-95
		CA-A- 2174648	27-04-95
		EP-A- 0734397	02-10-96
		US-A- 5529756	25-06-96

WO-A-9512608	11-05-95	US-A- 5503805	02-04-96
		AU-A- 1128095	23-05-95
		BR-A- 9407947	26-11-96
		EP-A- 0726906	21-08-96
		GB-A- 2298863	18-09-96

WO-A-9107504	30-05-91	NONE	

GB-A-2177200	14-01-87	DE-A- 3619107	08-01-87

EP-A-0542422	19-05-93	NONE	
