

(19)



(11)

EP 4 345 365 A1

(12)

EUROPEAN PATENT APPLICATION

(43) Date of publication:
03.04.2024 Bulletin 2024/14

(51) International Patent Classification (IPC):
F21S 4/10^(2016.01)

(21) Application number: **23200784.9**

(52) Cooperative Patent Classification (CPC):
**F21S 4/10; F21S 4/22; F21V 5/10; F21V 23/001;
F21V 23/005; F21V 23/06; F21V 31/04;
F21W 2131/406; F21Y 2113/10**

(22) Date of filing: **29.09.2023**

(84) Designated Contracting States:
**AL AT BE BG CH CY CZ DE DK EE ES FI FR GB
GR HR HU IE IS IT LI LT LU LV MC ME MK MT NL
NO PL PT RO RS SE SI SK SM TR**
Designated Extension States:
BA
Designated Validation States:
KH MA MD TN

(71) Applicant: **Spacecannon Sne S.r.l.
23845 Costa Masnaga (LC) (IT)**

(72) Inventor: **INVERNIZZI, Gianmario
23900 LECCO (IT)**

(74) Representative: **Modiano, Micaela Nadia et al
Modiano & Partners
Via Meravigli, 16
20123 Milano (IT)**

(30) Priority: **30.09.2022 IT 202200020085**

(54) **LED LAMP AND ASSOCIATED NETWORK**

(57) An LED lamp (1), comprising a lamp body with a power supply and command cable (5) which has an input connector (6) and an output connector (7), the pow-

er supply and command cable being provided by means of four wires for power supply and color control of the lamp via DMX512 protocol.

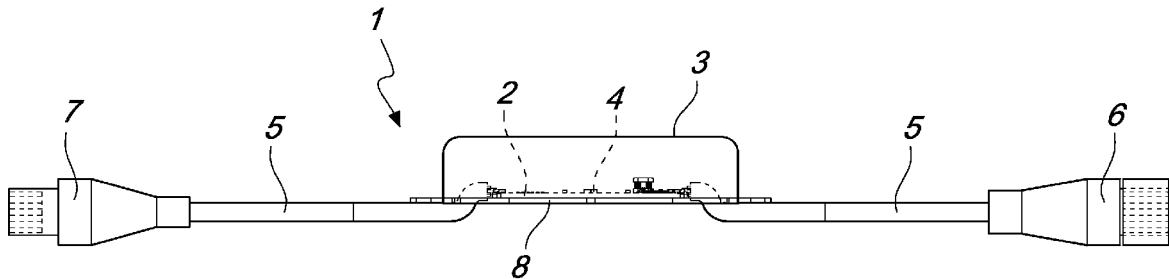

Fig. 1

EP 4 345 365 A1

Description

[0001] The present invention relates to an LED lamp and to an associated network of lamps connected in series to each other.

[0002] As is known, lamps or spotlights of the RGBW type, i.e., with red, green, blue and white LEDs, controlled via DMX512 protocol, are commercially available. This protocol allows to send a numerical value from 0 to 255 to 512 channels with a single three-conductor cable. The light control unit that controls a plurality of spotlights starts sending to the DMX chain the value of the first channel, then the value of the second channel, and so on up to the last channel that can be controlled by the unit, and then resumes from the first one.

[0003] Lamps or spotlights of the known type, controlled by means of the DMX512 protocol, require the use of five conductors, two for power supply (positive power conductor and negative power conductor) and three signal conductors, and four channels to manage the four colors of each lamp or spotlight.

[0004] This entails high costs and complexity of the hardware required to manage the lights.

[0005] The aim of the present invention is to provide an LED lamp and an associated lamp network in which it is possible to manage the lamps or spotlights with fewer wires than the traditional five used with the DMX512 protocol.

[0006] Within this aim, an object of the present invention is to provide an LED lamp and an associated network of lamps in which the management of the four colors, red, green, blue and white of the lamp, is possible with a reduced number of DMX512 channels with respect to the standard.

[0007] A further object of the present invention is to provide an LED lamp and a lamp network which is suitable for driving over.

[0008] Another object of the present invention is to provide an LED lamp and an associated lamp network which can be of different types for different kinds of use.

[0009] Not least object of the present invention is to provide an LED lamp and an associated network of lamps that is highly reliable, relatively easy to provide and at competitive costs.

[0010] This aim, as well as these and other objects which will become better apparent hereinafter, are achieved by an LED lamp, characterized in that it comprises a lamp body with a power supply and command cable which has an input connector and an output connector, the power supply and command cable being provided by means of four wires for power supply and color control of the lamp via DMX512 protocol.

[0011] Further characteristics and advantages of the invention will become better apparent from the description of preferred but not exclusive embodiments of the LED lamp according to the present invention, illustrated by way of non-limiting example in the accompanying drawings, wherein:

Figure 1 is a lateral elevation view of an LED lamp according to the present invention;

Figure 2 is a top plan view of the LED lamp of Figure 1;

Figure 3 is a front elevation view of an LED lamp according to the present invention, according to its second embodiment;

Figure 4 is a top plan view of the LED lamp of Figure 3;

Figure 5 is a view of a chain of LED lamps according to the present invention connected together in series.

[0012] With reference to the figures, in which identical reference numerals are matched by identical elements, the LED lamp according to the present invention is generally designated by the reference numeral 1 in a first embodiment.

[0013] The LED lamp 1 comprises a lamp body with a printed circuit board 2 with LEDs and control electronics. The printed circuit board 2 is conveniently embedded in a transparent resin casting 3.

[0014] The printed circuit board is provided with four RGBW LEDs 4, i.e., a red LED, a green LED, a blue LED, and a white LED, or a single white LED.

[0015] The lamp 1 is powered by a power supply and command cable 5 with an input connector 6 and has, at the opposite end, an output connector 7 that allows series connection to an additional connector 6 of a subsequent lamp 1.

[0016] Conveniently, a heat sink 8 is provided under the circuit board 2.

[0017] The power supply and command cable 5 provides for the use of four conductors instead of the traditional five required to handle the DMX512 protocol and the power supply, while maintaining the standard DMX512 protocol.

[0018] The four conductors are obtained by using a solution with common ground between the power supply and the signal, removing the shielding braid conductor.

[0019] The lamp according to the invention has an IP68 weather resistant rating and IK8/9 vandal resistant rating and is therefore suitable for driving over and can also be placed in the ground.

[0020] The use of only four conductors for the power supply and command cable 5 allow to save one conductor (as opposed to the canonical five), resulting in an associated cost saving.

[0021] Moreover, the four lamp colors, i.e., the four LEDs, can be managed using only three DMX512 channels. This allows to save one channel of the system, reducing the cost of the hardware required to manage the lights.

[0022] This is achieved by commanding the lighting of the white LED as a function of a mixing of the other three colors, obtained by means of a software program.

[0023] Figure 3 is a view of a second embodiment of the lamp, designated by the reference numeral 10, in which the transparent resin casting is provided in the form

of a porphyry cube 11 and has an internal cavity 12 that can be filled with resin.

[0024] A collimating lens 13 can be provided at the printed circuit board 2 and is accommodated within the cube 11.

[0025] The collimating lens or collimator 13 allows to obtain a directed beam of light that exits from the cube 11.

[0026] Moreover, it is possible to use a luminescent resin which, if activated by UV radiation, can glow even in the dark after the lamp is turned off.

[0027] This allows to save up to 45% energy by using the lamp with an on-off timer.

[0028] Moreover, it is possible to replace the cube 11 with a full resin casting of the printed circuit board resin having outgoing connected cables of appropriate dimensions.

[0029] Moreover, by means of a hole provided in the heat sink that is arranged behind the printed circuit board, it is possible to hang the lamps according to the invention, for example, on the face of a building, so as to form a matrix of pixels with a minimum spacing of, for example, 100 mm, thus creating a giant screen.

[0030] The lamps according to the invention, both according to the first and to the second embodiment, can be connected to each other in series so as to provide a network of lamps in which the first lamp of the network or line receives the address and provides the subsequent addresses to the other lamps connected in a sequential configuration.

[0031] Each lamp of the network can be controlled in terms of color shade independently of all the other lamps connected to the same control unit.

[0032] In practice it has been found that the lamp according to the present invention fully achieves the intended aim and objects, since it can be controlled in color management by using only three DMX512 channels and moreover allows to manage and power it with only four conductors.

[0033] The lamp thus conceived is susceptible of numerous modifications and variations, all of which are within the scope of the appended claims.

[0034] All the details may furthermore be replaced with other technically equivalent ones.

[0035] In practice, the materials used, as well as the contingent shapes and dimensions, may be any according to the requirements and the state of the art.

[0036] The disclosures in Italian Patent Application no. 102022000020085, from which this application claims priority, are incorporated herein by reference.

[0037] Where technical features mentioned in any claim are followed by reference signs, those reference signs have been included for the sole purpose of increasing the intelligibility of the claims and accordingly such reference signs do not have any limiting effect on the interpretation of each element identified by way of example by such reference signs.

Claims

1. An LED lamp (1; 10), **characterized in that** it comprises a lamp body with a power supply and command cable (5) which has an input connector (6) and an output connector (7), the power supply and command cable (5) being provided by means of four conductors for power supply and color control of the lamp via DMX512 protocol.
2. The lamp according to claim 1, **characterized in that** it comprises a printed circuit board (2) on which red, green, blue, white LEDs (4) and control electronics are arranged.
3. The lamp according to claim 1 or 2, **characterized in that** said LEDs (4) are controlled by using three DMX512 channels.
4. The lamp according to one or more of the preceding claims, **characterized in that** said printed circuit board (2) has a heat sink (8) in an underlying position.
5. The lamp according to one or more of the preceding claims, **characterized in that** it comprises a transparent resin casting (3) adapted to embed said printed circuit (2) with LEDs (4) and control electronics.
6. The lamp according to one or more of the preceding claims, **characterized in that** said transparent resin casting is provided by means of a cube (11) shaped like a porphyry cube.
7. The lamp according to claim 1, **characterized in that** said cube (11) comprises an internal cavity filled with resin.
8. The lamp according to one or more of the preceding claims, **characterized in that** said LEDs (4) comprise a single white LED.
9. The lamp according to one or more of the preceding claims, **characterized in that** it comprises, accommodated within said porphyry-like cube (11), a collimator (13) installed at the LEDs (4) of said printed circuit board (2).
10. The lamp according to one or more of the preceding claims, **characterized in that** said resin is a luminescent resin.
11. The lamp according to one or more of the preceding claims, **characterized in that** said heat sink (8) comprises a hole adapted to allow to hang said lamp.
12. A lighting network, **characterized in that** it comprises a plurality of lamps (1) according to one or more of the preceding claims, connected to each other in

series by means of said power supply and command cable (5).

5

10

15

20

25

30

35

40

45

50

55

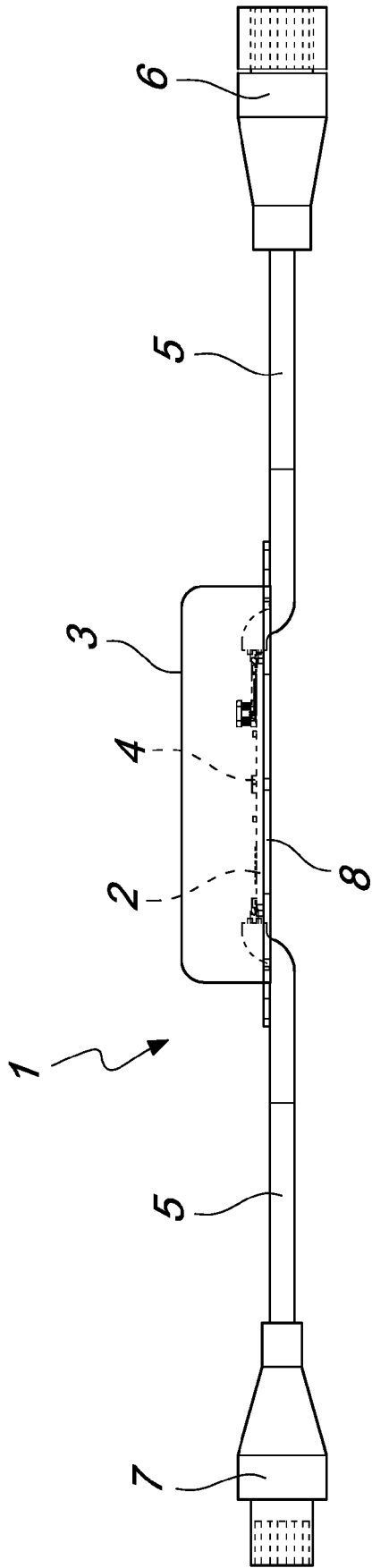

Fig. 1

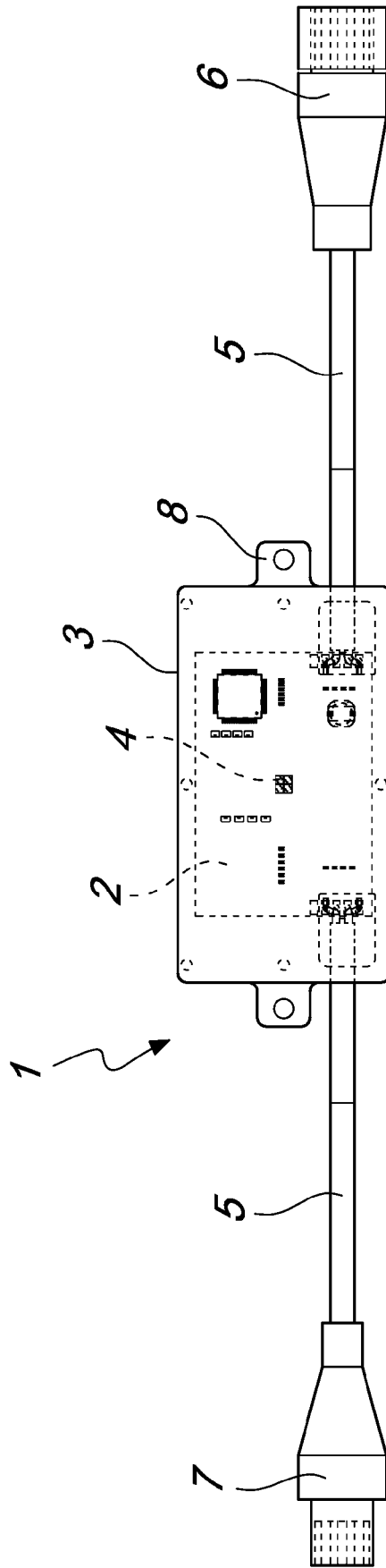

Fig. 2

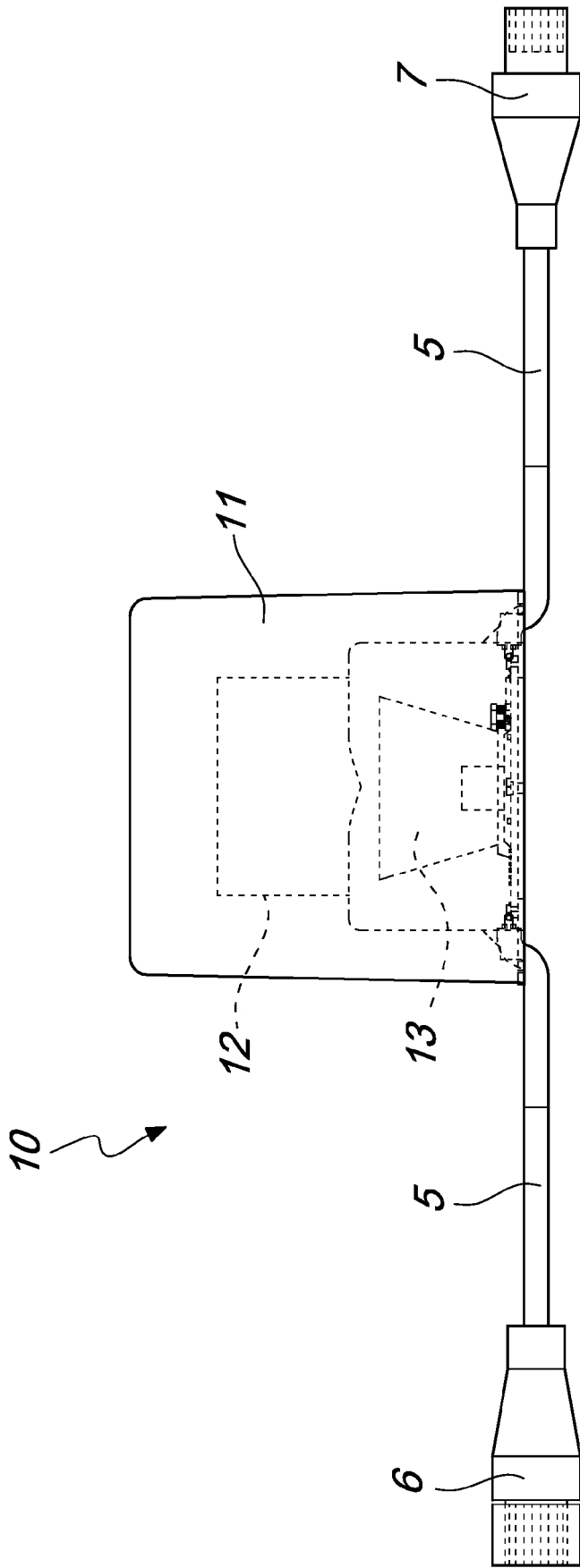

Fig. 3

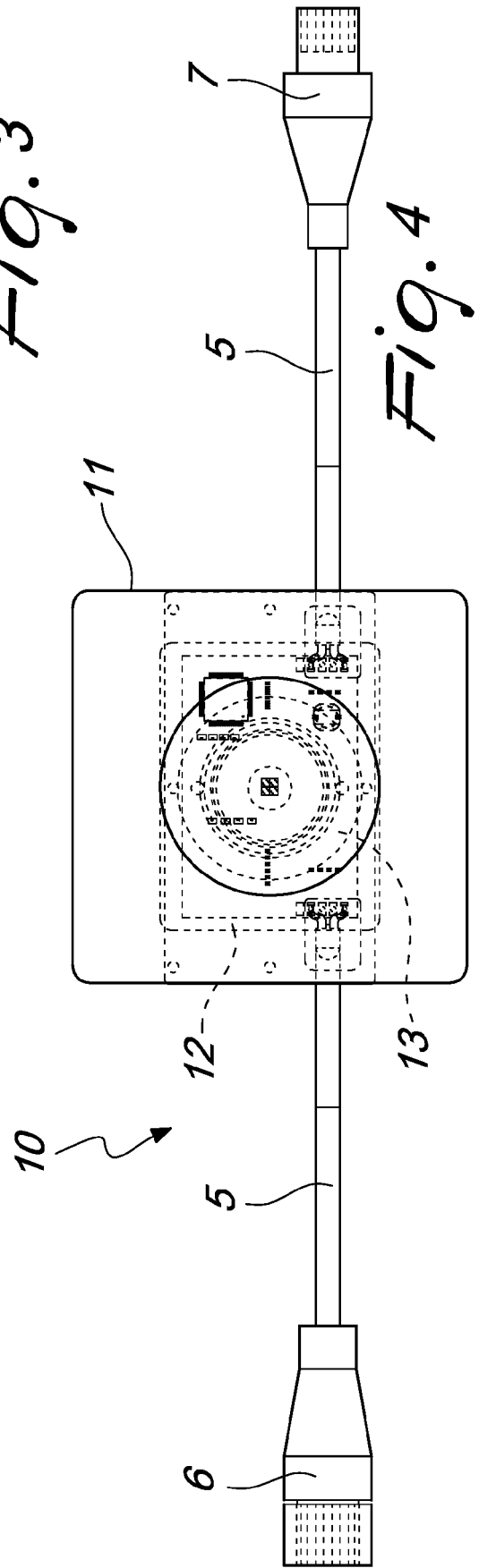

Fig. 4

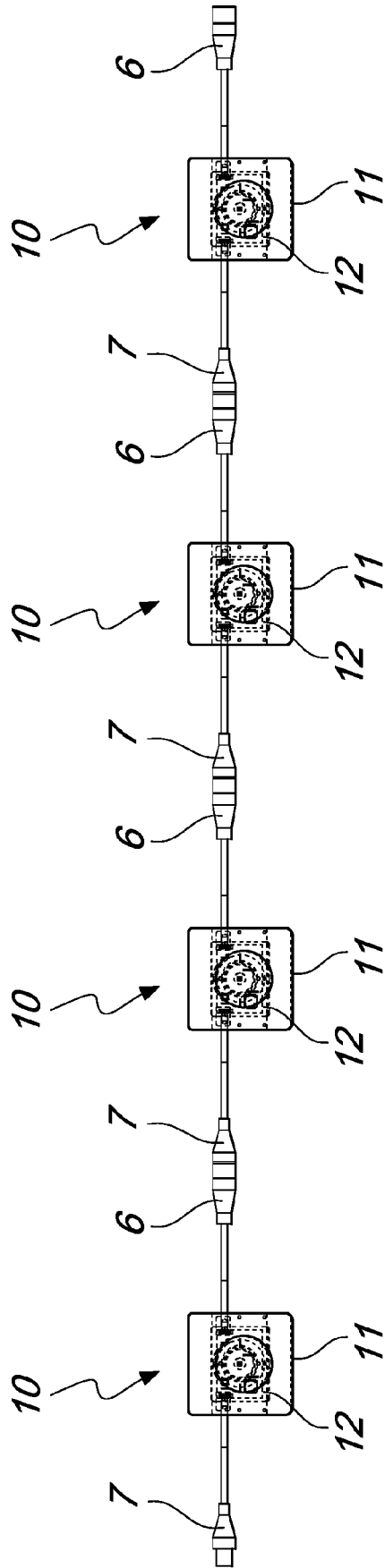

Fig. 5



EUROPEAN SEARCH REPORT

Application Number

EP 23 20 0784

5

DOCUMENTS CONSIDERED TO BE RELEVANT

10

15

20

25

30

35

40

45

Category	Citation of document with indication, where appropriate, of relevant passages	Relevant to claim	CLASSIFICATION OF THE APPLICATION (IPC)
X	CN 110 260 203 A (GUANGZHOU DASEN LIGHTING ELECTRONICS LTD) 20 September 2019 (2019-09-20) * figures 1-6 *	1-4, 8, 10-12	INV. F21S4/10 TECHNICAL FIELDS SEARCHED (IPC) F21S F21V F21W F21Y
Y	----- * figures 1-6 *	5-7, 9	
X	CN 110 798 950 A (GUANGZHOU DASEN LIGHTING ELECTRONICS LTD) 14 February 2020 (2020-02-14) * figures 1-3 *	1-4, 8, 12	
X	WO 2012/111334 A1 (LAPIN CREATE INC [JP]; WATANABE MASARU [JP]) 23 August 2012 (2012-08-23) * figures 1-9, 15, 16 *	1, 5, 12	
Y	----- * figures 1-9, 15, 16 *	2, 3, 6-11	
Y	CN 205 859 709 U (NEW WORLD DEV COMPANY LTD; NEW WORLD POWER RESOURCES CO LTD) 4 January 2017 (2017-01-04) * figures 1, 2 *	2-4, 8	
A	----- * figures 1, 2 *	1	
Y	WO 2015/154015 A2 (DFX SOUND VISION [US]) 8 October 2015 (2015-10-08) * figures 1-4 *	3	
A	----- * figures 1-4 *	1	
Y	WO 2012/039507 A1 (SUZUDEN COMPANY LTD [JP]; SUZUDEN HANBAI COMPANY LTD [JP] ET AL.) 29 March 2012 (2012-03-29) * figures 1-6 *	2-8, 10, 11	
A	----- * figures 1-6 *	1, 12	
Y	WO 2010/075679 A1 (TONG YUXIAN [CN]; PAN DIANBO [CN]) 8 July 2010 (2010-07-08) * figures 1-9 *	5-7, 9-11	
A	----- * figures 1-9 *	1	

1

The present search report has been drawn up for all claims

50

Place of search The Hague	Date of completion of the search 18 December 2023	Examiner Kebemou, Augustin
-------------------------------------	---	--------------------------------------

55

EPO FORM 1503 03:82 (P04C01)

CATEGORY OF CITED DOCUMENTS
 X : particularly relevant if taken alone
 Y : particularly relevant if combined with another document of the same category
 A : technological background
 O : non-written disclosure
 P : intermediate document

T : theory or principle underlying the invention
 E : earlier patent document, but published on, or after the filing date
 D : document cited in the application
 L : document cited for other reasons

 & : member of the same patent family, corresponding document

ANNEX TO THE EUROPEAN SEARCH REPORT
ON EUROPEAN PATENT APPLICATION NO.

EP 23 20 0784

5 This annex lists the patent family members relating to the patent documents cited in the above-mentioned European search report.
The members are as contained in the European Patent Office EDP file on
The European Patent Office is in no way liable for these particulars which are merely given for the purpose of information.

18-12-2023

Patent document cited in search report	Publication date	Patent family member(s)	Publication date
CN 110260203 A	20-09-2019	NONE	
CN 110798950 A	14-02-2020	CN 110798950 A CN 211047302 U	14-02-2020 17-07-2020
WO 2012111334 A1	23-08-2012	JP WO2012111334 A1 WO 2012111334 A1	03-07-2014 23-08-2012
CN 205859709 U	04-01-2017	NONE	
WO 2015154015 A2	08-10-2015	CA 2944752 A1 US 2018199413 A1 WO 2015154015 A2	08-10-2015 12-07-2018 08-10-2015
WO 2012039507 A1	29-03-2012	JP 5268166 B2 JP 2012089466 A US 2013176735 A1 WO 2012039507 A1	21-08-2013 10-05-2012 11-07-2013 29-03-2012
WO 2010075679 A1	08-07-2010	NONE	

REFERENCES CITED IN THE DESCRIPTION

This list of references cited by the applicant is for the reader's convenience only. It does not form part of the European patent document. Even though great care has been taken in compiling the references, errors or omissions cannot be excluded and the EPO disclaims all liability in this regard.

Patent documents cited in the description

- IT 102022000020085 [0036]