

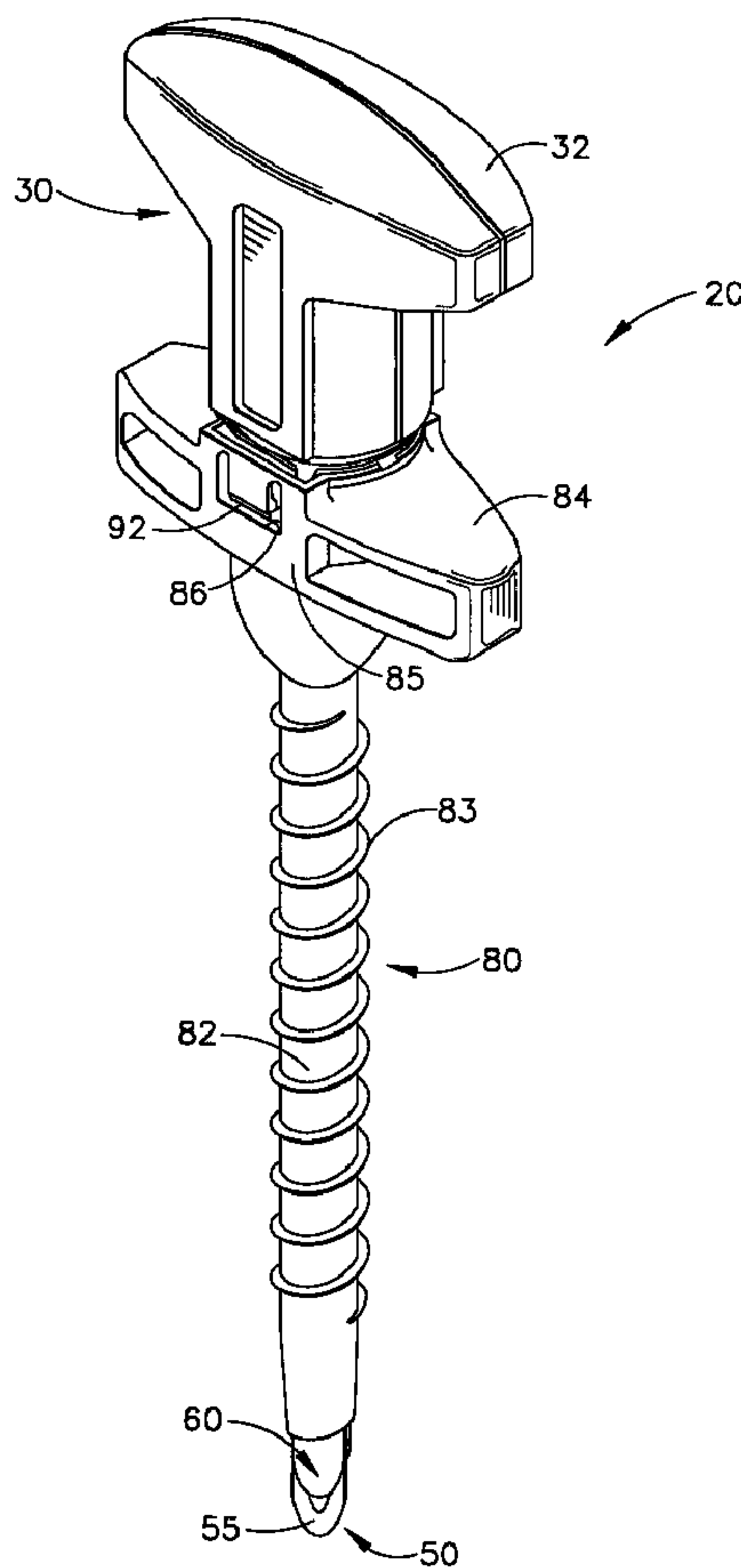

(22) Date de dépôt/Filing Date: 1998/03/24
 (41) Mise à la disp. pub./Open to Public Insp.: 1998/09/26
 (45) Date de délivrance/Issue Date: 2007/06/19
 (30) Priorité/Priority: 1997/03/26 (US08/827,317)

(51) Cl.Int./Int.Cl. *A61B 17/34* (2006.01)
 (72) Inventeurs/Inventors:
 SCHWEMBERGER, RICHARD F., US;
 POWELL, DARREL M., US;
 PRIVITERA, SALVATORE, US;
 KELLY, WILLIAM D., US;
 KEILHOLZ, DAVID J., US
 (73) Propriétaire/Owner:
 ETHICON ENDO-SURGERY, INC., US
 (74) Agent: OGILVY RENAULT LLP/S.E.N.C.R.L.,S.R.L.

(54) Titre : TROCART MUNI D'UNE GAINE DE PROTECTION A EXTREMITÉ FLEXIBLE
 (54) Title: TROCAR HAVING PROTECTOR WITH FLEXIBLE END



(57) Abrégé/Abstract:

A surgical trocar has a cannula assembly including a sleeve having a proximal end, a distal end and a passageway therethrough. A housing having an opening is located at the proximal end of the sleeve and is aligned with the passageway of the sleeve. The trocar

(57) **Abrégé(suite)/Abstract(continued):**

also includes an obturator assembly which is insertable in the cannula assembly. The obturator assembly includes a handle and an obturator shaft. The obturator shaft has a proximal end connected to the handle and a distal end opposite the proximal end. A penetrating tip is located at the shaft distal end for penetrating tissue. A protector having a distal end is slidably disposed around the obturator shaft for covering the penetrating tip. The protector has an aperture at its distal end for permitting the penetrating tip to pass therethrough. The protector also includes a flexible proximal end movable against the obturator handle to expose the penetrating tip when a proximal force is asserted against the protector.

TROCAR HAVING PROTECTOR WITH FLEXIBLE END

ABSTRACT

A surgical trocar has a cannula assembly including a sleeve having a proximal end, a distal end and a passageway therethrough. A housing having an opening is located at the proximal end of the sleeve and is aligned with the passageway of the sleeve. The trocar also includes an obturator assembly which is insertable in the cannula assembly. The obturator assembly includes a handle and an obturator shaft. The obturator shaft has a proximal end connected to the handle and a distal end opposite the proximal end. A penetrating tip is located at the shaft distal end for penetrating tissue. A protector having a distal end is slidably disposed around the obturator shaft for covering the penetrating tip. The protector has an aperture at its distal end for permitting the penetrating tip to pass therethrough. The protector also includes a flexible proximal end movable against the obturator handle to expose the penetrating tip when a proximal force is asserted against the protector.

TROCAR HAVING PROTECTOR WITH FLEXIBLE END

FIELD AND BACKGROUND OF THE INVENTION

5

The present invention relates in general to endoscopic surgery, and in particular, to trocars having shields or protectors for use in endoscopic surgical procedures.

10

The use of endoscopic procedures in surgery has become widely accepted. The term endoscopic as used herein is defined to include all types of minimally invasive surgical procedures including laparoscopic and arthroscopic procedures. Accordingly, numerous endoscopic instruments have been developed which allow the surgeon to perform complex surgical procedures with minimal incisions into the skin and tissue surrounding a particular body cavity or anatomical region. In order to introduce the endoscopic instrumentation into the body cavity, it is often necessary to puncture and cannulate the body cavity by using a trocar. Trocars are widely known in the art and typically consist of an obturator and a trocar cannula. It is common for a sealing arrangement or seal assembly to be used in association with the cannula to prevent the escape of fluid or gas during endoscopic procedures. Trocars may have a protective element around the obturator which covers the sharp piercing tip of the obturator prior to and after insertion, and also after removal of the obturator and trocar cannula. The protective element is often referred to as a safety shield or protector.

25

One type of trocar utilizes a safety shield and is typically inserted by pressing the distal end of the trocar assembly against the outer skin of the patient with sufficient force to cause the piercing end of the obturator to pierce through the skin, underlying fat, muscle and fascia into the body cavity. The trocar is permitted to penetrate into the body cavity because the safety shield is retracted proximally thereby exposing the sharp piercing tip. However, upon completing the penetration, the safety shield automatically returns to its protective position

30

END-398

covering the piercing tip. This type of trocar is a fully returnable safety shielded trocar. Once the surgeon has properly positioned the trocar within the body cavity, the obturator together with the safety shield are removed and the trocar cannula is then available as a pathway, e.g., for insertion of endoscopic
5 instrumentation. U.S. Patent 5,387,197 (Smith et al.) describes this type of trocar.

With current fully returnable safety shielded trocars, it may be necessary to remove the cannula handle from the obturator handle to "reload" the shield on the
10 trocar obturator for those instances where the trocar has not completely penetrated into the body cavity. In this fashion, therefore, it is necessary to perform an extra step while the obturator tip is inserted within pneumoperitoneum.

Yet, in some procedures it may be desirable to utilize trocars without a
15 safety shield or to utilize a trocar design wherein the trocar obturator is nonshielded at the time when the trocar obturator is placed within the trocar cannula. Thus, upon coupling of the shielded obturator and the cannula, the shield will be retracted thereby exposing the piercing tip of the obturator. This type of trocar can be referred to as an assembly actuated trocar.

20 An assembly actuated trocar prevents the shield from returning to its protective position upon placement of the obturator within the cannula. U.S. Patent 5,248,298 (Bedi et al.) describes this type of trocar. In this way, the user is able to slightly withdraw the trocar from the pierced tissue, and then continue
25 penetrating through remaining tissue layers. This prevents what is commonly referred to as "tenting" of pneumoperitoneum. In this fashion, tenting can be reduced while still adequately providing access to the body cavity.

In an effort to eliminate problems with tenting or to reduce cost from
30 surgery, surgeons often utilize trocars that do not employ a safety shield since these types of trocars are generally less expensive than fully returnable safety shielded trocars. However, for those procedures that utilize trocars without a
END-398

safety shield, there is a possibility that the obturator tip could cut a person handling the trocar or damage the trocar seal assembly or other components of the instrument.

5 Presently, there is no known trocar that provides a low cost option to the surgeon while maintaining the ability to protect the obturator piercing tip with a shield or protector up until the time when the obturator is coupled to the proximal end of the cannula.

10 SUMMARY OF THE INVENTION

The present invention is a surgical trocar for use in endoscopic surgical procedures such as minimally invasive procedures, laparoscopic procedures, arthroscopic procedures or the like.

15

The surgical trocar according to the present invention comprises a cannula assembly including a sleeve having a proximal end, a distal end and a passageway therethrough. A housing having an opening is located at the proximal end of the sleeve and is aligned with the passageway of the sleeve. The trocar also includes
20 an obturator assembly which is engagable with the cannula assembly. The obturator assembly includes a handle and an obturator shaft. The obturator shaft has a proximal end connected to the handle and a distal end opposite the proximal end. A penetrating tip is located at the distal end of the obturator shaft.

25 The obturator assembly also includes a protector slidably disposed around the obturator shaft for covering the obturator penetrating tip. The protector has an aperture at a distal end of the protector for permitting the penetrating tip of the obturator shaft to pass therethrough. The protector also includes a flexible proximal end which is slidably movable against a contact portion of the handle for
30 exposing the penetrating tip past the protector aperture and the sleeve distal end when the handle comes in contact with the housing upon the insertion of the obturator assembly into the cannula assembly. Thus, upon inserting the obturator
END-398

assembly into the cannula assembly, a proximal force is applied to the protector which moves the protector proximally such that the flexible proximal end of the protector slidably moves against the contact portion of the handle. This contact causes the flexible proximal end to flex or deflect as the flexible proximal end is
5 slidably moved against the contact portion of the handle.

According to the present invention, there are several embodiments for the flexible proximal end of the protector. One embodiment includes a pair of deflectable arms. A second embodiment for the flexible proximal end of the
10 protector includes a sinusoidal member integral with the protector.

Another alternative embodiment according to the present invention provides a surgical trocar, and more particularly, an obturator assembly comprising a handle having an opening therein and a flexible engagement portion.
15 The obturator shaft extends through the handle opening and has a proximal end fixed to the handle and a distal end with a penetrating tip thereon. A protector is slidably disposed around the obturator shaft and extends through the handle opening for covering the penetrating tip of the obturator shaft. The protector has an aperture at a distal end thereof which permits the penetrating tip of the
20 obturator shaft to pass therethrough. The protector also has a proximal end which is slidably movable against the flexible engagement portion of the handle in order to retract the protector to a retracted position for exposing the penetrating tip when a proximal force is placed against the protector.

25 One advantage of the present invention is to provide a surgical trocar that provides protection for the surgeon or others all the way up until the moment that the obturator assembly is engaged with the cannula assembly.

Another advantage according to the present invention is to provide a
30 surgical trocar that provides protection for the trocar seal and other components of the trocar.

Another advantage of the present invention is to provide a surgical trocar that eliminates tenting of the peritoneum.

5 It is another advantage of the present invention to provide a surgical trocar having an obturator protector to be used as a secondary port for endoscopic surgical procedures.

10 According to a further broad aspect of the present invention, there is provided an improved surgical trocar comprising a cannula assembly including a sleeve having a proximal end and a distal end and a passageway therethrough and a housing having an opening and being
15 located at said proximal end of said sleeve, said housing opening being aligned with said passageway of said sleeve, an obturator assembly insertable into said cannula assembly and including a handle, an obturator shaft having a proximal end connected to said handle and
20 a distal end opposite said proximal end, and a penetrating tip located at said distal end of said obturator shaft, wherein the improvement comprises: a protector having a distal end and slidably disposed around said obturator shaft for covering said penetrating
25 tip of said obturator shaft in a protected position, said protector having an aperture at said distal end for permitting said penetrating tip of said obturator shaft to pass therethrough; said protector also having a flexible proximal end movable against said handle for
30 moving said protector to a retracted position from said protected position in order to expose said penetrating tip past said protector aperture and said sleeve distal end upon a proximal force being exerted upon said

protector, said protector returning to said protected position when said proximal force is released from said protector.

5 According to still further broad aspect of the present invention, there is provided an obturator assembly comprising: a handle having an opening therein and a contact portion; an obturator shaft extending through said handle opening and having a proximal end
10 fixed to said handle and a distal end having a penetrating tip thereon; and a protector slidably disposed around said obturator shaft and also extending through said handle opening for covering said penetrating tip of said obturator shaft in a protected position, said
15 protector having an aperture at a distal end thereof for permitting said penetrating tip of said obturator shaft to pass therethrough, said protector also having a flexible proximal end movable against said contact portion of said handle for moving said protector to a
20 retracted position from said protected position in order to expose said penetrating tip when a proximal force is placed against said protector, said protector returning to said protected position when said proximal force is released from said protector.

25 The various features of novelty which characterize the invention are pointed out with particularity in the claims annexed to and forming a part of this disclosure. For a better understanding of the
30 invention, its operating advantages and specific objects attained by its uses, reference is made to the accompanying drawings and descriptive matter in which preferred embodiments of the invention are illustrated.

BRIEF DESCRIPTION OF THE DRAWINGS

Fig. 1 is a perspective view of a trocar having
5 an obturator and a cannula according to the present
invention;

Fig. 2 is a plan view in section of the trocar
obturator with a penetrating tip in a covered position
10 according to the present invention;

Fig. 3 is a plan view in section of the
obturator of Fig. 2 in a coupled relationship with the
cannula of Fig. 1 with the penetrating tip in an exposed
15 position;

Fig. 4 is a perspective view, partially broken
away, illustrating a protector according to the present
invention;

20

Fig. 5 is an exploded perspective view of the
obturator and the cannula of Fig. 1;

Fig. 6 is a perspective view of a seal assembly employed in the cannula of Fig. 5;

5 Fig. 7 is a side elevational view of the seal assembly shown in Fig. 6;

Fig. 8 is a front elevational view of the seal assembly shown in Fig. 6;

10 Fig. 9 is a plan view in section of an alternative embodiment of a trocar according to the present invention; and

Fig. 10 is an alternate embodiment of the protector of Fig. 3.

15 DESCRIPTION OF THE PREFERRED EMBODIMENTS

As best shown in Fig. 1, the present invention is a low cost surgical trocar, generally designated 20, utilized as an assembly actuated trocar for endoscopic surgical procedures to include all minimally invasive surgical procedures such as laparoscopic and arthroscopic surgical procedures. The surgical trocar 20 is disposable and is intended to be used as a single patient use only device, meaning that the trocar 20 according to the present invention is to be used on only one patient for a particular surgical procedure and then after such usage, the trocar 20 is to be discarded.

25

The surgical trocar 20 is similar to the trocars found in U.S. Patents 5,709,671; 5,609,604; 5,697,913; 5,224,952; 5,256,149; 5,314,417; 5,387,197; 5,248,298; 5,330,437; 5,399,167; 5,066,288; 5,215,526 and 5,267,965.

30

The surgical trocar 20 includes an obturator assembly, generally designated 30, which is insertable through a cannula assembly, generally designated 80, for establishing a surgical access port. Fig. 2 shows the obturator assembly 30 comprising a handle 32 having an opening 34 at a lower portion of the handle 32. The handle 32 also includes a contact portion, generally designated 36, having a pair of first retaining ribs 37 and a pair of second retaining ribs 39 positioned proximally to the pair of first retaining ribs 37. Additionally, the contact portion 36 also includes a first ramp surface 41 and a second ramp surface 43 positioned at an obtuse angle to the first ramp surface 41.

10

An obturator shaft 45 having a first retained portion 47 and a second retained portion 49 at a proximal end of the obturator shaft 45 are fixedly secured to the handle 32 at the first retaining ribs 37 and the second retaining ribs 39 respectively. The remainder of the obturator shaft 45 extends from the handle 32 through the handle opening 34.

15

The obturator shaft 45 also includes a penetrating tip, generally designated 50, which is a blade assembly comprising a flat blade 55 for penetrating tissue and a pair of upper shoulders 53. The penetrating tip 50 is fixed to the distal end of the obturator shaft 45.

20

A protector sleeve 57 having a channel 61 therethrough is slidably disposed around the obturator shaft 45. The protector 57 also includes a flexible proximal end 59 which is located, along with the proximal portion of the obturator shaft 45, within the handle 32. As shown in Fig. 4, the protector 57 is a single piece of molded plastic. The protector proximal end 59 includes a pair of deflectable arms 62 that are resilient and flexible enough so that the deflectable arms 62 can be deflected outwardly from the obturator shaft 45, but yet resume their original shape and size after deflection without breaking away from the protector 57. However, it is not intended that the protector 57 be limited merely to molded plastic, but can also include any type of material that contains the required

25

30

properties and characteristics for the flexible proximal end 59 such as described above.

5 The protector deflectable arms 62 include an inner surface 64 and an end surface 68 at the end portion of each deflectable arm 62 as shown in Fig. 4. The end surfaces 68 of the protector deflectable arms 62 are initially located distally from the first ramp surfaces 41 of the handle contact portion 36 thus defining a gap between the first ramp surfaces 41 and the deflectable arm end surfaces 68.

10 Similar to the obturator shaft 45, the protector 57 extends from the handle 32 through the handle opening 34. The protector 57 also includes a dilating tip section 67 located at the distal end of the protector 57 for dilating tissue after the trocar 20 is inserted into tissue for establishing a surgical access port.

15 The protector 57 also includes a boss 66 circumferentially arranged around the exterior of the protector 57 and positioned near the handle opening 34. The dilating tip section 67 of the protector 57 includes an aperture 60 which communicates with the channel 61 of the protector 57. The aperture 60 is located at the distal end of the protector 57 for permitting the penetrating tip 50 of the
20 obturator shaft 45 to pass therethrough.

The dilator tip 67 also includes a slot 69 which vertically extends from the aperture 60 to a point near the distal end of the protector 57 for permitting the penetrating tip 50 to pass therethrough (Fig. 4). The protector 57 also includes a
25 stop 65 circumferentially arranged within the channel 61 at the dilator tip 67 for being supported by with the upper shoulders 53 of the penetrating tip 50.

30 Since, the flexible proximal end 62 of the protector 57 is located near the contact portion 36 within the handle 32, the protector 57 is slideably movable around the obturator shaft 45 between the upper shoulders 53 of the penetrating tip 50 of the obturator shaft 45 and the handle contact portion 36. The stop 65 is

supported by the upper shoulders 53 of the penetrating tip 50 for preventing the protector 57 from disengaging from the obturator handle 32.

As best illustrated in Fig. 2, the obturator assembly 30 is in a protected
5 position meaning that the protector 57 is extended beyond the penetrating tip 50
thereby covering the penetrating tip 50 and preventing any inadvertent cutting by
the flat blade 55.

Fig. 5 shows the cannula assembly 80 comprising a cannula sleeve 82
10 defining a central passageway therethrough and a seal housing 85 located at the
proximal end of the sleeve 82. The sleeve 82 has a helical thread 83 on an
exterior surface of the sleeve 82 for positioning the sleeve 82 in tissue. The
housing 85 also includes a handle portion 84 which extends outwardly and
substantially perpendicular from opposite sides of the housing 85. The housing 85
15 includes a central opening 87 for receiving a seal assembly, generally designated
100, therein. The seal assembly 100 is disposed in the central opening 87 and is
seated above the cannula sleeve 82. The housing 85 also includes a seal retainer
90 having two retainer locks 92 and is seated against the upper surface of the seal
assembly 100 and fixed to the cannula housing 85. The seal retainer 90 is a
20 conical plastic ring which permits the obturator assembly 30 to be inserted directly
through the seal assembly 100.

The housing 85 also includes a pair of retainer lock slots 86 located on opposite sides of the housing 85 for receiving the retainer locks 92 of the seal retainer 90. Accordingly, the retainer locks 92 of the retainer 90 are pressed fit into the retainer lock slots 86 of the housing 85 as best illustrated in Fig. 1.

5

As best illustrated in Fig. 3, the penetrating tip 50 is exposed by retracting the protector 57 to a retracted position proximally within the cannula handle 32. Upon a proximal force F being asserted against the protector 57, the deflectable arm end surfaces 68 contact the first ramp surfaces 41 of the handle contact portion 36 and are slidably movable across the first ramp surfaces 41 of the handle contact portion 36. After initial contact of the end surfaces 68 with the first ramp surfaces 41, the deflectable arms 62 are deflected outwardly away from the obturator shaft 45 as the protector 57 is forced proximally within the handle 32 through the application of proximal force F since the deflectable arms 62 are made of a resilient, flexible material. Due the material properties of the proximal end 59, an opposing force is applied to the protector 57 as the deflectable arms 62 are slidably moved against the contact portion 36. These material properties cause the protector 57 to return distally to a protected position when the proximal force F is released from the protector 57.

10
15
20

Once the deflectable arm end surfaces 68 are slid past the first ramp surfaces 41, the inner surfaces 64 of the deflectable arms 62 contact the second ramp surfaces 43 of the handle contact portion 36 and are slidably movable across the second ramp surfaces 43. Accordingly, the end surfaces 68 and the inner surfaces 64 of the deflectable arm 62 are slideably movable against the first ramp surfaces 41 and the second ramp surfaces 43 of the handle contact portion 36 respectively to facilitate a smooth retraction of the protector 57 within the obturator handle 32. The first ramp surfaces 41 are arranged substantially perpendicular to the obturator shaft 45 in order to provide a sufficient resistive surface for the deflectable arms 62 to prevent the deflectable arms 62 from easily sliding past the first ramp surfaces 41. This arrangement ensures that the protector 57 is not inadvertently withdrawn into the obturator handle 32 until intended.

25
30
END-398

Because the second ramp surfaces 43 are at an obtuse angle with respect to the first ramp surfaces 41, there is a less resistive surface for the deflectable arms 62. This allows the protector 57 to be easily retracted at this point in the retraction.

5 The protector is retracted to its retracted position through the application of the proximal force F which can be applied to the protector 57 manually, for instance, by the surgeon grasping the protector boss 66 and withdrawing the protector 57 proximally toward the handle 32. Alternatively, the protector 57 is retracted to its retracted position upon insertion of the obturator assembly 30
10 through the cannula assembly 80 and into the cannula sleeve 82 until the dilator tip 67 of the protector 57 extends through the distal end of the cannula sleeve 82 as shown in Figs. 1 and 3 and up until the point where the protector boss 66 contacts the handle 32 at the handle opening 34. At this point, the boss 66 of the protector 57 will contact the inner surface of the conically-shaped retainer 90 thereby
15 causing the proximal force F to be asserted against the protector 57. The proximal force F advances the protector 57 proximally within the handle 32 for extending the penetrating tip 50 through the protector aperture 60 thereby exposing the flat blade 55 for cutting tissue. The handle opening 34 has a smaller diameter than the outer diameter of the circumferentially arranged protector boss 66 such that the
20 protector boss 66 cannot be inserted within the obturator handle 32.

 Additionally, as shown in Fig. 5, the obturator handle 32 also includes retaining pins 33 laterally extending from the handle adjacent the handle opening 34. Thus, the obturator assembly 30 can be locked to the cannula assembly 80 by
25 rotating the retaining pins 33 into the pin slots 94 of the seal retainer 90 through a slight rotation motion of the handle 32 once the obturator assembly 30 has been inserted through the cannula assembly 80 thereby forming the assembly actuated trocar 20.

30 The handle 32 is unlocked merely through reversing the rotation action such that the rotating pins 33 disengage from the pin slots 94 which will cause the protector 57 to return to its protected position covering the penetrating tip 50. The
END-398

resilient, flexible properties of the protector proximal end 59 will cause the protector 57 to advance distally over the penetrating tip 50 upon the decoupling of the handle 32 from the cannula housing 85.

5 As shown in Figs. 6-8, the seal assembly 100 includes a housing seal 104 which is a circumferential elastomeric member that surrounds a diaphragm seal 108. The diaphragm seal has a central aperture 110 therethrough and has a substantially convex shape which extends upwardly and outwardly from the housing seal 104. A flange 112 surrounds the outer periphery of the housing seal
10 104.

 Additionally, the seal assembly 100 includes an S-shaped pressure seal 120 comprising two sidewalls 122 extending distally from the under side of the housing seal 104 and the diaphragm seal 108. As shown in Fig. 8, each sidewall 122 has
15 an end section 126 that is adjacent to each other and define an S-shaped slit 128 therebetween. Accordingly, the central aperture 110 and the S-shaped slit 128 of the seal assembly 100 permit the obturator assembly 30 to be inserted therethrough in sealing engagement thereby preventing the loss of operating fluid. However, once the cannula assembly 80 has been placed, the obturator assembly 30 can be
20 withdrawn from the cannula assembly 80 for the insertion of additional surgical instruments through the cannula assembly 80 for facilitating the surgical procedure. Similar to obturator assembly 30, additional surgical instruments inserted through the seal assembly 100 are sealed by the seal assembly 100, particularly by the S-shaped pressure seal and the diaphragm seal 108.

25 A second embodiment of a protector 57a according to the present invention is illustrated in Fig. 10 wherein the protector 57a includes a flexible proximal end 59a which is a sinusoidal member 72 having a central bore 73 and a pair of proximal tips 74 having a notch 76 interposed between each tip 74. The notch 76
30 and the central bore 73 are aligned directly with the channel 61 of the protector 57a. Both the notch 76, the central bore 73, along with the channel 61 of the protector 57a are shaped to receive the obturator shaft 45 due to their direct
END-398

alignment with each other. The proximal tips 74 are positioned near the first ramp surfaces 41 of the handle engagement portion 36 for contacting the first ramp surfaces 41 upon proximal force F being asserted against the protector 57a in the manner described above. The tips 74 are relatively flat members that will contact
5 the first ramp surfaces 41 without advancing to the second ramp surfaces 43.

Similar to the protector 57 (Fig. 4) described above, the protector 57a is also made of molded plastic as single, integral component. The sinusoidal member 72 through both its configuration and material composition is a resilient,
10 flexible member which permits the protector 57a to function similar to the protector 57 (Fig. 4) described above.

Another embodiment according to the present invention is illustrated in Fig. 9 wherein the trocar 20 includes a protector 57b having a proximal end 70.
15 The contact portion 36 of the cannula handle 32 comprises a pair of deflectable members 48 that are movable by the proximal end 70 of the protector 57b. The deflectable members 48 are made of a flexible and resilient material such that once the proximal force F is asserted against the protector 57b, the proximal end 70 of the protector 57b is advanced proximally into the contact portion 36 slidably
20 moving against the inner surfaces of the deflectable members 48. The protector proximal end 70 outwardly deflects the deflectable members 48 away from the obturator shaft 45 thereby retracting the protector 57b and exposing the penetrating tip 50. Accordingly, this alternative arrangement provides similar advantages to the preferred embodiment shown in Figs. 2-5.

As mentioned above, the trocar 20 according to the present invention provides several advantages. In particular, the trocar 20 is an assembly actuated trocar and is directed to being the trocar of choice in the current cost conscious surgical environment. Since cost is a major issue with the present surgical community, it is often necessary to develop novel and creative instruments and techniques in order to provide safe, efficacious and quality surgical treatment for the patient, while at the same time seeking to reduce cost from the surgical procedure. One creative way of reducing cost from a surgical procedure afforded by the present invention, is to utilize a single fully returnable safety shielded trocar such as those described as part of the field and background of the invention, along with one or more of the trocars 20 according to the present invention.

Since a fully returnable shield trocar is more costly than the trocar 20 according to the present invention, mainly due to the cost of additional parts and manufacturing, many surgeons will seek to limit the number of fully returnable safety shielded trocars utilized during a single surgical procedure. Thus, many surgeons may opt to utilize only one fully returnable safety shielded trocar in order to establish a primary access port in the patient. The primary access port being established once the safety shielded obturator is removed from the cannula and an endoscope is inserted in its place in order to establish visualization for the placement for secondary access ports.

The secondary access ports are utilized to accommodate various types of surgical instrumentation in order to facilitate the surgical procedure. Accordingly, the trocar 20 according to the present invention can be utilized to establish these secondary access ports. As illustrated in Fig. 2, since the trocar 20 according to the present invention utilizes a protector 57, the penetrating tip 55 will be covered, and accordingly, a degree of safety is provided to all those who handle the obturator assembly 30 prior to the engagement and locking of the obturator assembly 30 into the cannula assembly 80. Additionally, the seal assembly 100 of the trocar 20 also will be protected since the penetrating tip 55 remains covered as the obturator is slid through the seal assembly 100 into the cannula sleeve 82.

END-398

Although this invention has been described in connection with its most preferred embodiments, it will become readily apparent to those reviewing this detailed specification that numerous additional embodiments fall well within the
5 scope and spirit of the claimed invention as set forth in the claims which appear below.

- 16 -

CLAIMS,

1. An improved surgical trocar comprising a cannula assembly including a sleeve having a proximal end and a distal end and a passageway therethrough and a housing having an opening and being located at said proximal end of said sleeve, said housing opening being aligned with said passageway of said sleeve, an obturator assembly insertable into said cannula assembly and including a handle, an obturator shaft having a proximal end connected to said handle and a distal end opposite said proximal end, and a penetrating tip located at said distal end of said obturator shaft, wherein the improvement comprises:

a protector having a distal end and slidably disposed around said obturator shaft for covering said penetrating tip of said obturator shaft in a protected position, said protector having an aperture at said distal end for permitting said penetrating tip of said obturator shaft to pass therethrough;

said protector also having a flexible proximal end movable against said handle for moving said protector to a retracted position from said protected position in order to expose said penetrating tip past said protector aperture and said sleeve distal end upon a proximal force being exerted upon said protector, said protector returning to said protected position when said proximal force is released from said protector.

2. The surgical trocar according to claim 1, wherein said flexible proximal end of said protector includes at least one deflectable arm slidably movable against a contact portion of said handle.

3. The surgical trocar according to claim 2, wherein said flexible proximal end of said protector includes a pair

- 17 -

of deflectable arms slidably movable against said contact portion of said handle.

4. The surgical trocar according to claim 3, wherein said contact portion includes a first ramp surface and each deflectable arm includes an end surface at a proximal end of each arm for slidably moving against said first ramp surface of said contact portion.

5. The surgical trocar according to claim 4, wherein said contact portion further includes a second ramp surface adjacent said first ramp surface and each deflectable arm includes an inner surface adjacent said end surface for slidably moving against said second ramp surface.

6. The surgical trocar according to claim 5, wherein said protector includes a boss for contacting said handle when said protector is retracted to said retracted position.

7. The surgical trocar according to claim 6, including a seal assembly located in said opening of said housing.

8. The surgical trocar according to claim 7, wherein said housing includes at least one slot and said handle includes at least one pin detachably engagable with said at least one slot for locking said handle to said housing.

9. The surgical trocar according to claim 8, wherein said penetrating tip includes a flat blade.

10. The surgical trocar according to claim 9, wherein said protector includes a dilation section at said distal end of said protector.

- 18 -

11. The surgical trocar according to claim 10, wherein said sleeve includes a helical thread on an exterior surface of said sleeve.

12. The surgical trocar according to claim 1, wherein said proximal force is exerted against said protector when said handle contacts said housing upon an insertion of said obturator assembly into said cannula assembly.

13. An obturator assembly comprising:

a handle having an opening therein and a contact portion;

an obturator shaft extending through said handle opening and having a proximal end fixed to said handle and a distal end having a penetrating tip thereon; and

a protector slidably disposed around said obturator shaft and also extending through said handle opening for covering said penetrating tip of said obturator shaft in a protected position, said protector having an aperture at a distal end thereof for permitting said penetrating tip of said obturator shaft to pass therethrough, said protector also having a flexible proximal end movable against said contact portion of said handle for moving said protector to a retracted position from said protected position in order to expose said penetrating tip when a proximal force is placed against said protector, said protector returning to said protected position when said proximal force is released from said protector.

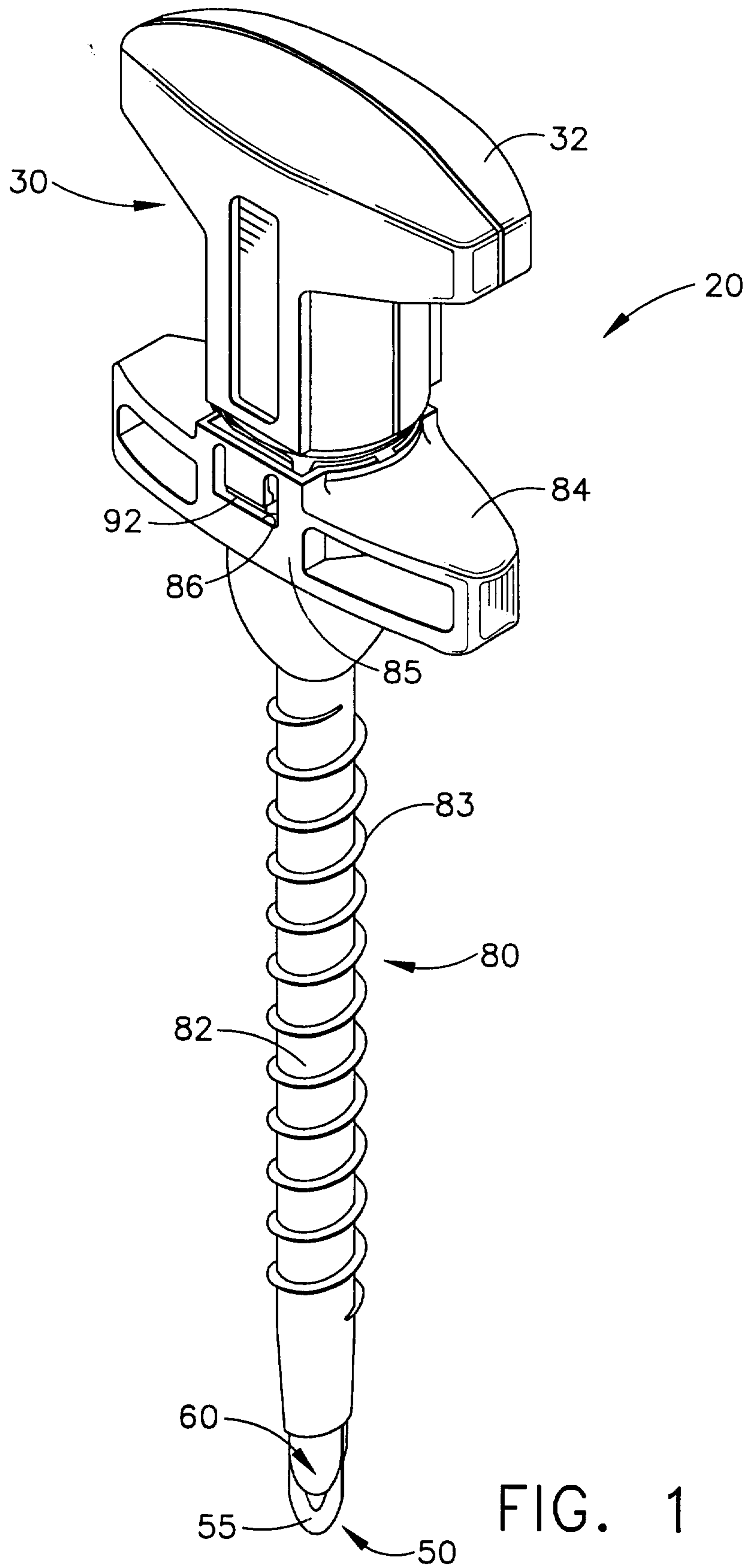

FIG. 1

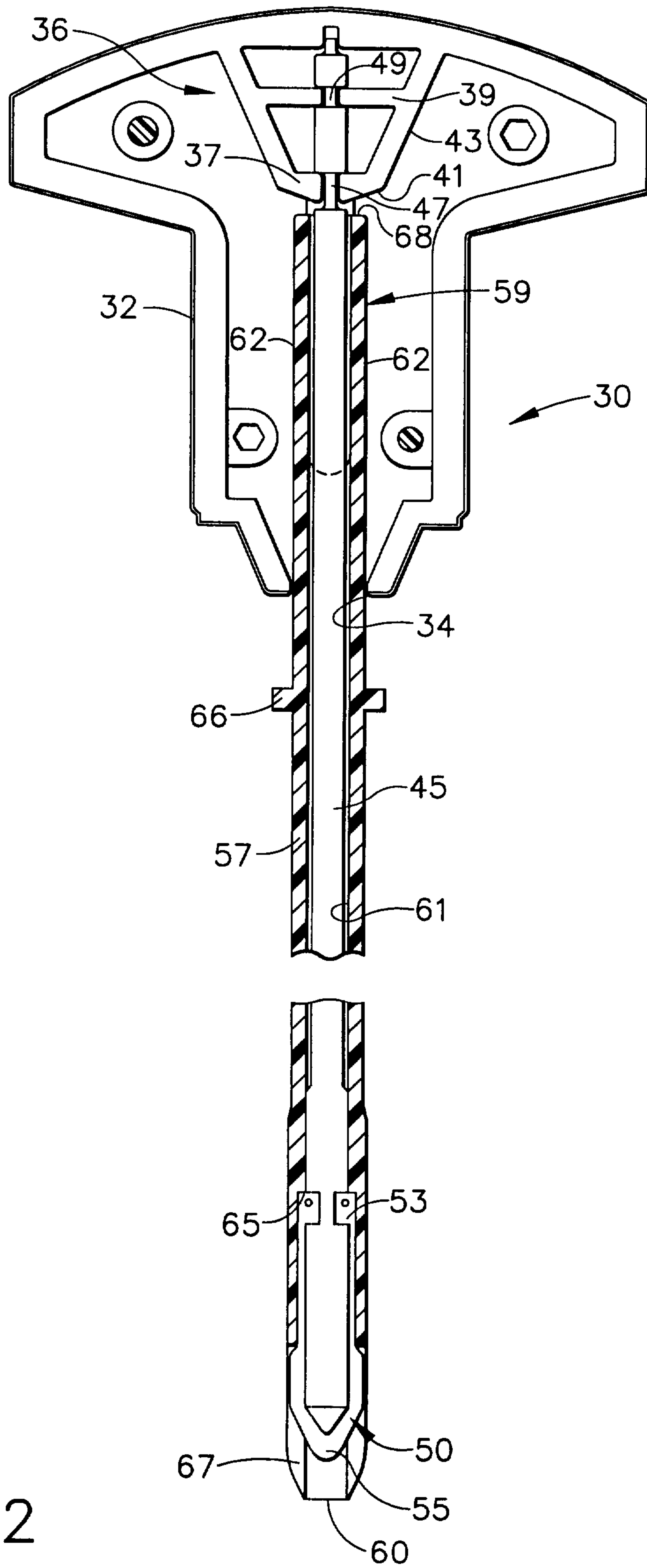

FIG. 2

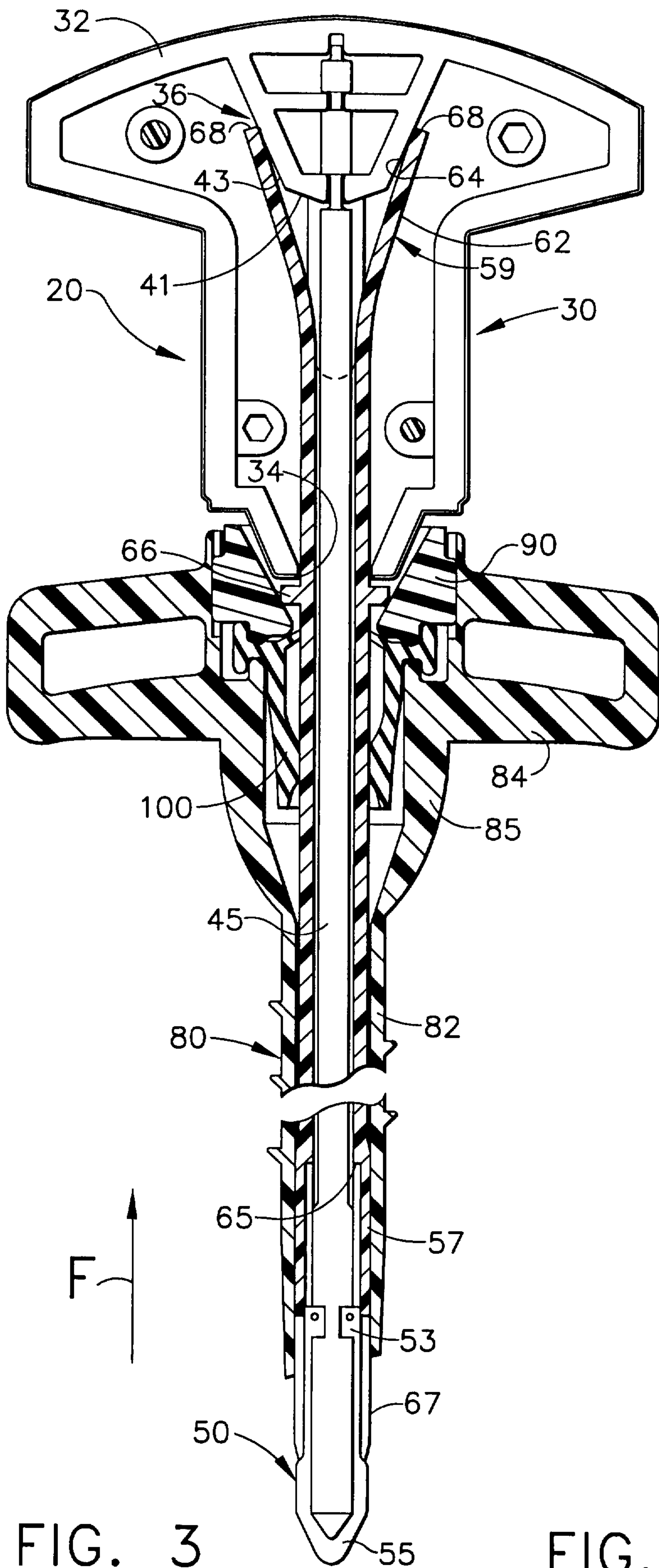

FIG. 3

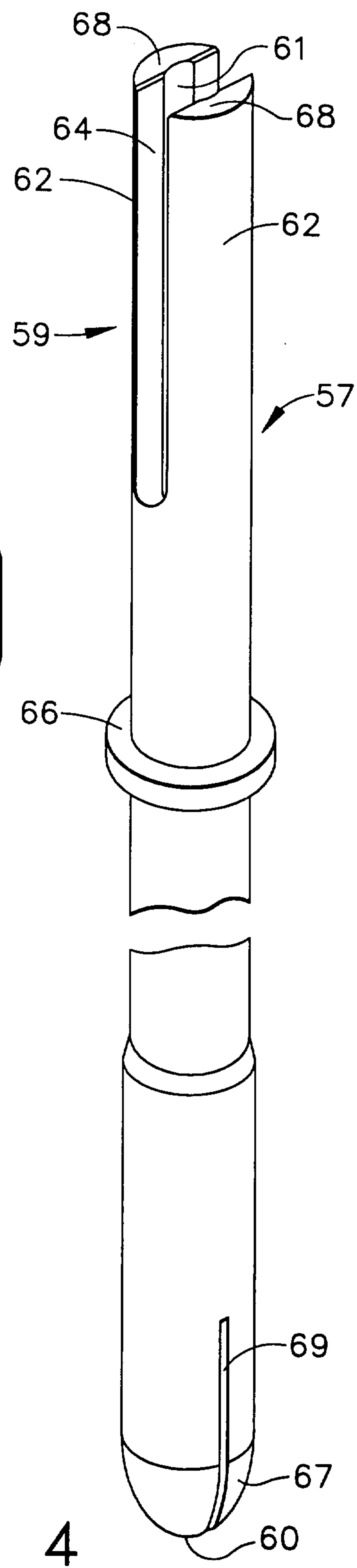

FIG. 4

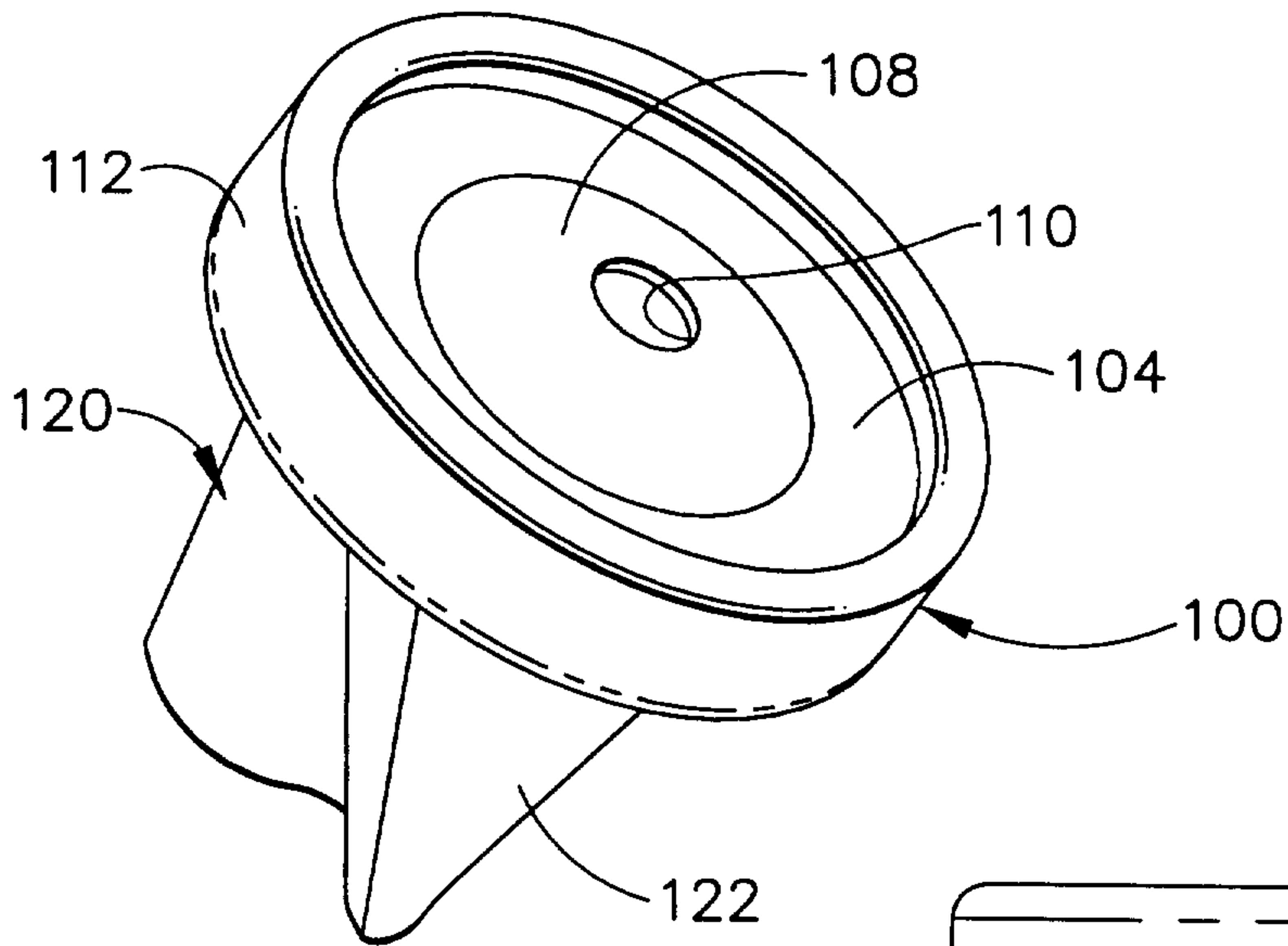

FIG. 6

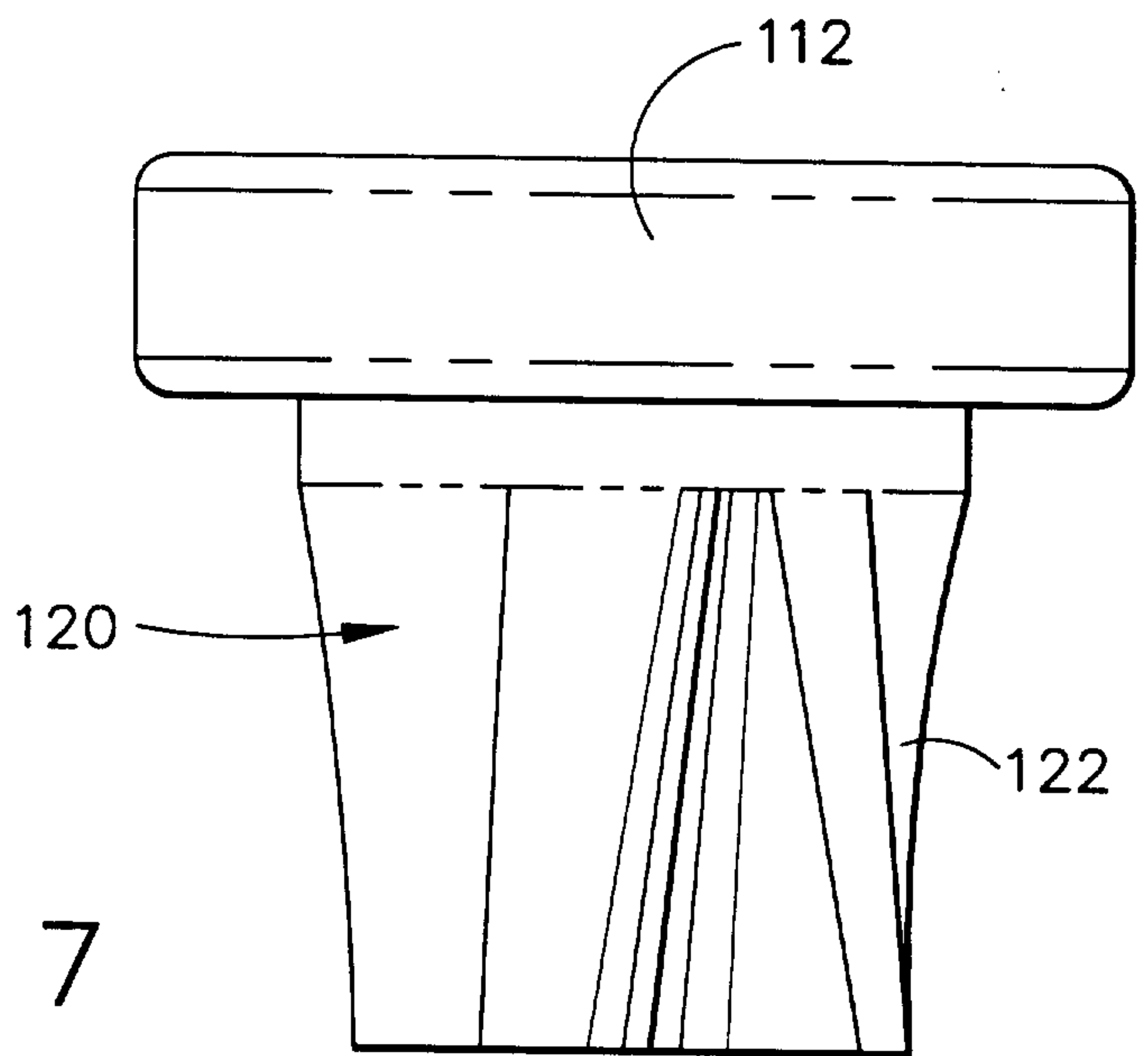

FIG. 7

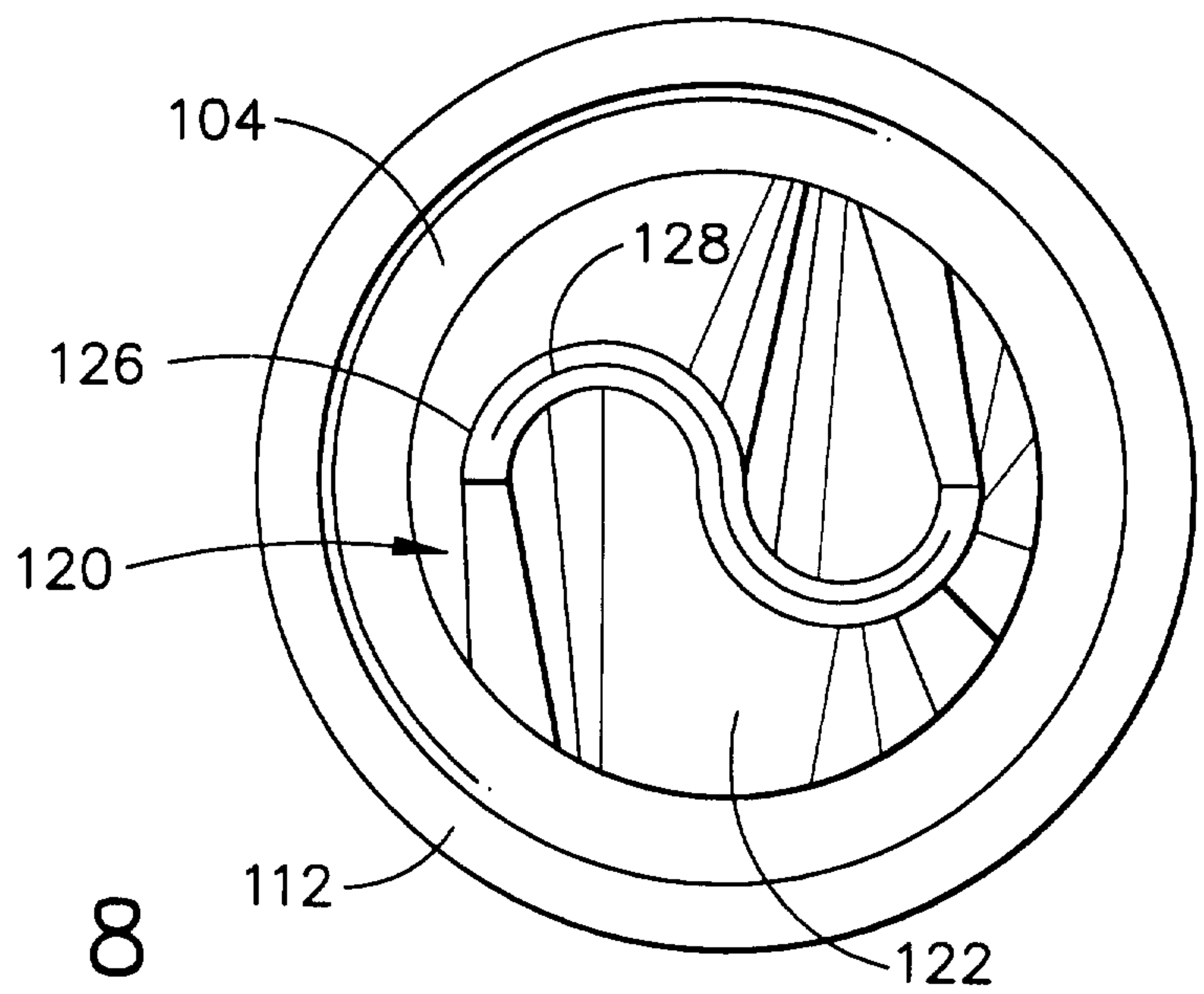

FIG. 8

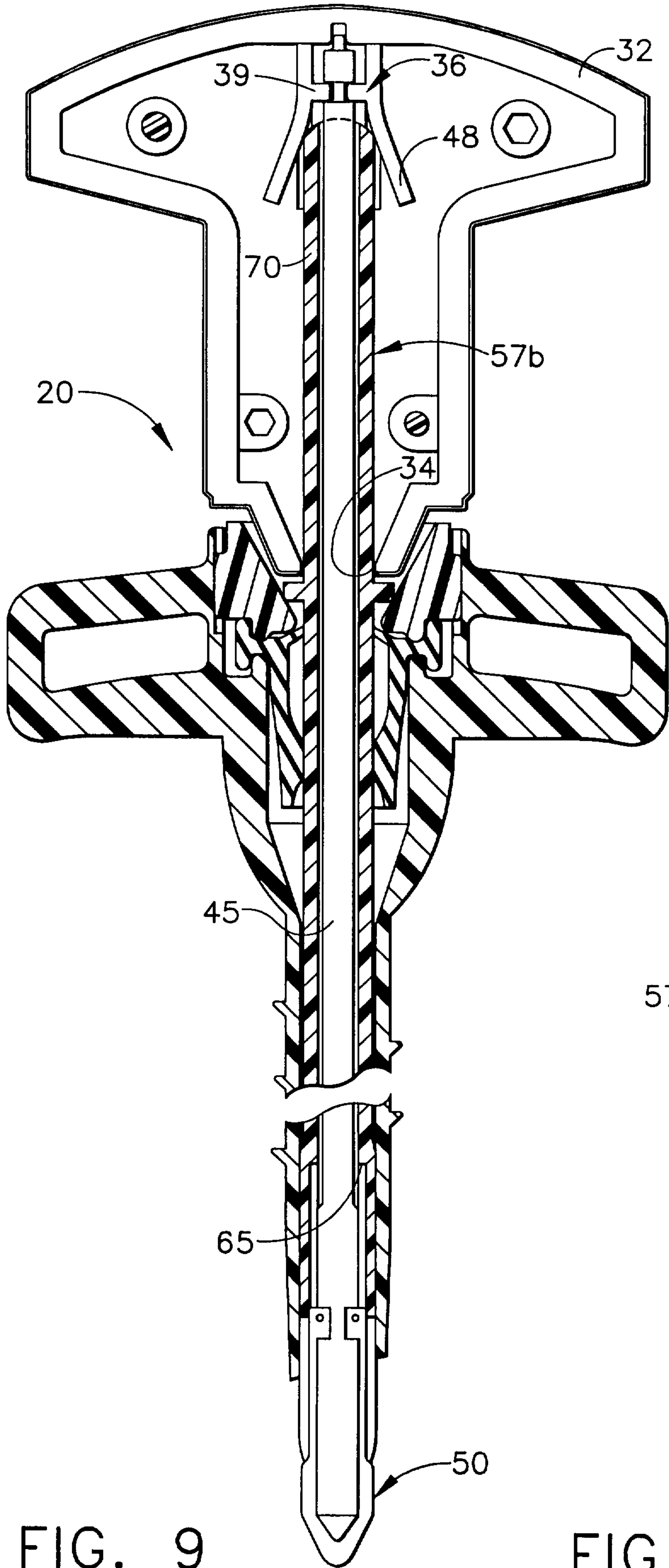

FIG. 9

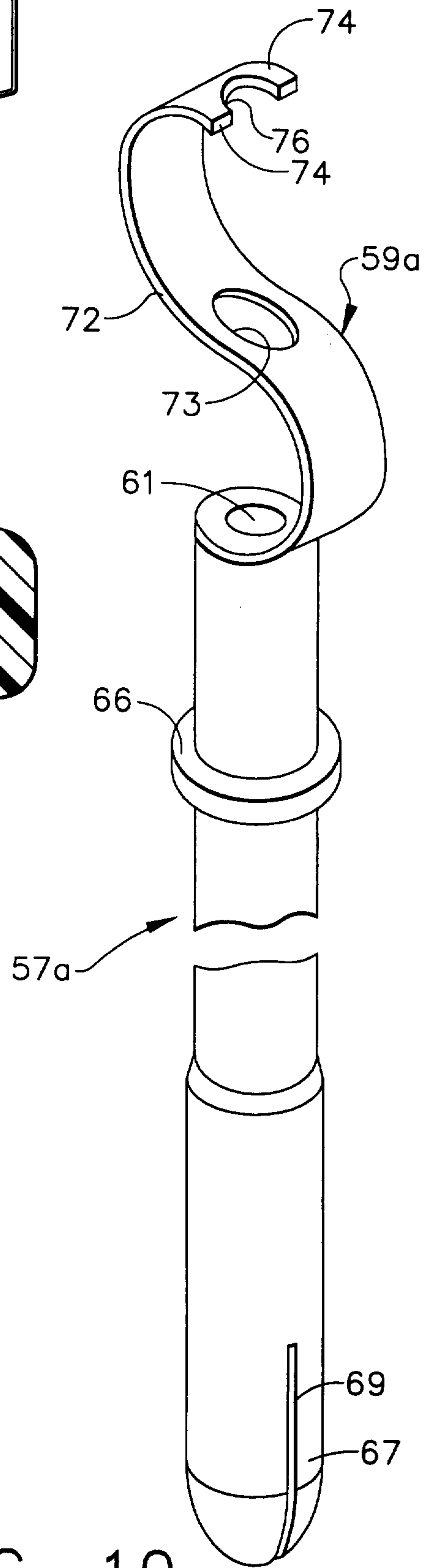

FIG. 10

