

No. 649,781.

Patented May 15, 1900.

A. VOLTOR.
MEANS FOR PROPELLING VESSELS.

(Application filed Oct. 27, 1899.)

(No Model.)

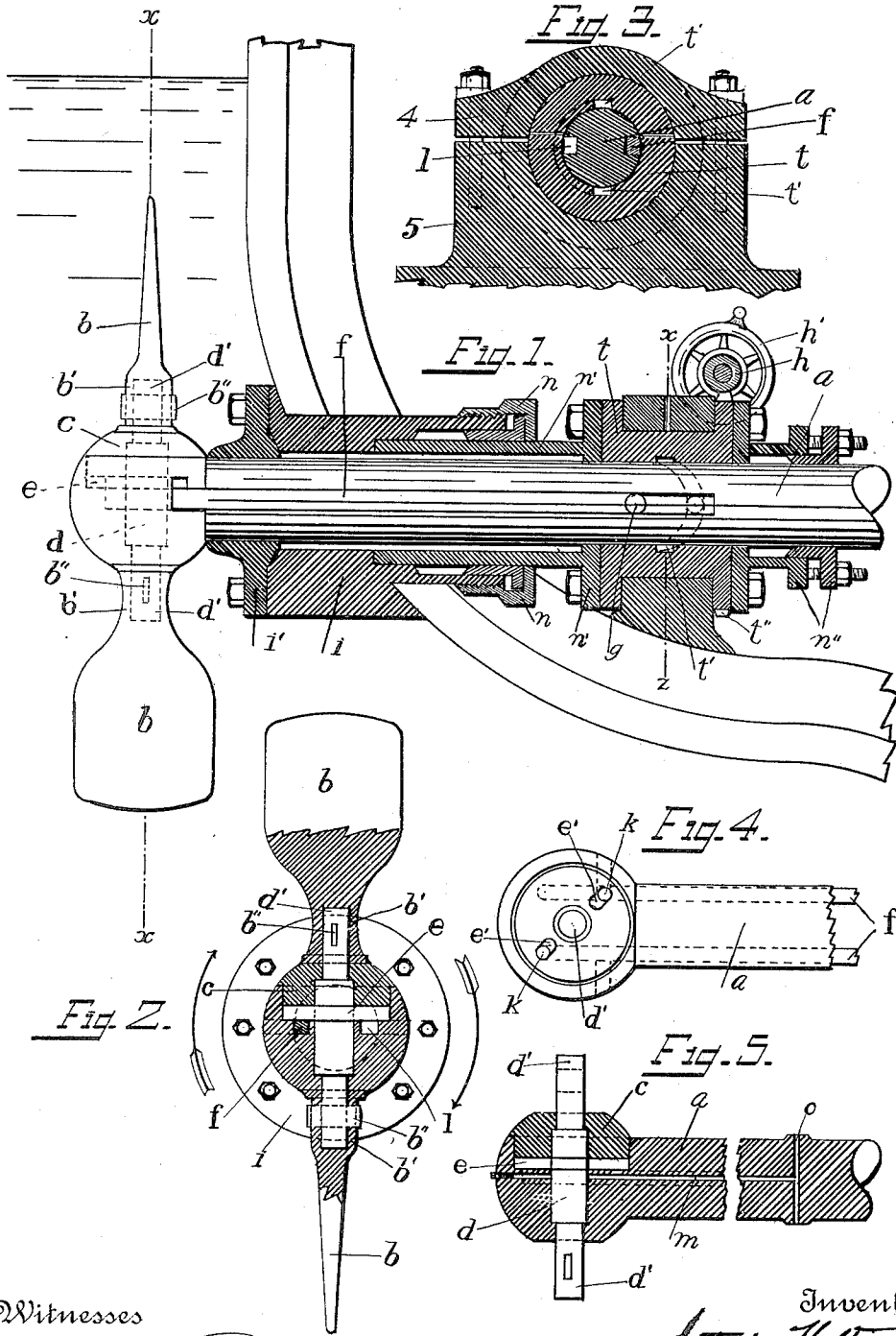

Witnesses
Clarence A. Bateman
John Melvin Wilson

Inventor
Antonio Voltor
 by *Walters & Fisher*
 Attorneys

UNITED STATES PATENT OFFICE.

ANTONIO VOLTOR, OF BARCELONA, SPAIN.

MEANS FOR PROPELLING VESSELS.

SPECIFICATION forming part of Letters Patent No. 649,781, dated May 15, 1900.

Application filed October 27, 1899. Serial No. 734,982. (No model.)

To all whom it may concern:

Be it known that I, ANTONIO VOLTOR, manufacturer, residing at Barcelona, in the Province of Barcelona and Kingdom of Spain, have invented certain new and useful Improvements in Means for the Propulsion of Vessels; and I do hereby declare the following to be a full, clear, and exact description of the invention, such as will enable others skilled in the art to which it appertains to make and use the same.

This invention relates to improvements in means for the propulsion of ships or the like, more especially to that class of ships using side propellers which are entirely submerged.

In order to more fully explain the said invention, reference will be had to the accompanying drawings, in which—

Figure 1 is a longitudinal section of the invention as applied to the side of a ship. Fig. 2 is an end view showing parts in section on the line xx , Fig. 1. Fig. 3 represents a transverse section on the line zz , Fig. 1. Fig. 4 is a view showing the construction of the end of the main or driving shaft, and Fig. 5 is a longitudinal section of the same.

Similar parts are indicated by the same letters and numerals of reference throughout the several views, in which—

a , Fig. 1, designates the main or driving shaft, formed at one end with an enlarged portion.

b designates the propeller-blades, each of which is provided with a socket b' .

The enlarged portion of the shaft a is provided with a removable plug or cap c , which allows the small transversely-disposed rock-shaft d to be placed into position.

e designates a slotted circular disk rigidly secured upon the rock-shaft d .

d' d' are reduced portions of the rock-shaft d , and are adapted to enter the sockets b' upon the propeller-blades b , and are secured therein by means of the keys b'' .

Running longitudinally of the shaft a and at opposite sides of the said shaft are the grooves l , into each of which fits a rod or bar f . Upon one end of each of these rods or bars is a stud k , each of which enters one of the elongated openings e' in the disk e . Upon the other end of each of these rods or bars is provided another stud g , both of these studs

following the cam-groove t' in the bushing t as the main or driving shaft a is rotated, one of said studs resting in said cam-groove diametrically opposite to the other. The bushing t is fitted snugly upon the shaft a and is supported in the bearing formed by the parts 4 and 5. This bushing acts as one of the bearings for the shaft a and is provided with a toothed crown t'' , which is engaged by the worm-wheel h , the hand-wheel h' being provided for rotating the said worm-wheel, and thereby rotating the bushing t .

n n' represent portions of a stuffing-box, the part n' being secured to the bushing t and the portion n being secured upon the bearing i , to which is attached the journal-bearing i' . To the other end of the bushing t is secured the stuffing-box n'' upon the inner end of the main or driving shaft a .

m shows an oil-conduit which runs longitudinally of the shaft a and communicates with the transverse shaft d and with the transverse conduit o .

The operation is as follows: Power being applied to the shaft a from any suitable source, the shaft a is caused to revolve, say, in the direction of the arrows, Fig. 2. The revolving of the main shaft carries with it the rods f , thereby causing the studs g to follow the cam-groove t' in the bushing t . This causes the rods to reciprocate first in one direction and then in the opposite direction, the relative positions of these rods being such that they reciprocate in opposite directions. This reciprocating movement of the rods f causes the studs k thereon to rotate the annular disk e first one-quarter of a revolution and then the same distance in the opposite direction. The shaft d being rigidly attached to the disk e , the rocking motion imparted to it will also be imparted to the rock-shaft, which finally imparts its motion to the propeller-blades. These blades are secured upon the shaft d in such a manner that the flat portion of the blade of one propeller is parallel with the plane of rotation of the shaft a , while the other blade is at right angles thereto. By means of the rods f , reciprocated by the cam-groove t' and acting upon the circular disk e , these blades are caused to rotate, so that when the shaft is revolving in the assumed direction each blade is caused to rotate

tate in such a manner as to offer the flat side of the blade to the water below the driving-shaft and to propel the ship along, while the blade upon the opposite end of the shaft *d* is passing through the water edgewise, offering very little resistance. This same motion is repeated each time that the main shaft makes a revolution, as will be obvious, thus causing the ship to move in one direction.

I provide a novel means for reversing the direction of the vessel without reversing the direction in which the main or driving shaft revolves, which I will now describe.

Referring to Fig. 3, it will be seen that the bushing *t* is rotatably mounted in the bearing 4 5. By turning the hand-wheel *h'* this bushing is caused to rotate, which motion is continued until it has rotated one hundred and eighty degrees or half a revolution. It will be seen that this rotation has changed the position of the cam-groove *t'*, so that instead of the blades propelling the water below the main shaft, as was assumed in the previous case, they will now be propelling the water above the shaft, or, in other words, the reaction of the water upon the propeller will be reversed while the driving-shaft *a* continues to revolve in the same direction.

Lubrication of the various parts is effected as follows: Oil is forced into the grooves of the shaft occupied by the rods *f* and is returned after lubricating the shaft *d* and its attachments by means of the conduits *m* and *o*.

While I have shown my invention as applied to only one side of a vessel, it will be understood that one propeller is situated upon each side of the ship, or, if found desirable, a plurality may be placed upon each side of the ship.

It is obvious that many changes might be made in the details of my said invention without departing from the spirit thereof; but

What I claim, and desire to secure by Letters Patent of the United States, is—

1. The combination with a driving-shaft, of a rock-shaft mounted transversely through one end of said shaft, propeller-blades mounted upon said rock-shaft, a disk rigidly secured upon said latter shaft, and means for imparting a rocking motion to said disk, substantially as described.

2. The combination with a driving-shaft, of a rock-shaft mounted transversely in one end of said shaft, propeller-blades mounted axially upon the ends of said rock-shaft, the planes formed by said blades being at right angles, and means for rocking said rock-shaft, substantially as described.

3. The combination with a driving-shaft mounted transversely of a ship, of a rock-shaft mounted transversely through one end of said driving-shaft, propeller-blades mounted upon the ends of said rock-shaft, means for rocking said rock-shaft first in one direction and then back the same distance during the revolution of said driving-shaft, and

means for reversing the directions of rotation of said rock-shaft during one revolution of said driving-shaft, substantially as described.

4. The combination with a driving-shaft mounted transversely of a ship, of a rock-shaft mounted transversely through one end of said driving-shaft, propeller-blades axially mounted upon the ends of said rock-shaft, the blades forming planes at right angles to each other, means for partially rotating said rock-shaft first one way then back during one revolution of said driving-shaft, and means for reversing the order of rotation of said rock-shaft, substantially as described.

5. The combination with a driving-shaft mounted transversely of a ship, bars mounted in grooves running longitudinally of said driving-shaft, and studs upon the ends of said bars, of a rock-shaft mounted transversely through one end of said driving-shaft, propeller-blades secured to the ends of said rock-shaft, a circular disk rigidly mounted upon said rock-shaft, provided with elongated openings adapted to be engaged by the studs upon the said bars, and means for reciprocating said bars, substantially as described.

6. The combination with a driving-shaft mounted transversely of a ship, bars mounted in grooves running longitudinally of said driving-shaft, and studs upon the ends of said bars, of a rock-shaft mounted transversely through one end of said driving-shaft, propeller-blades secured to the ends of said rock-shaft, a circular disk rigidly mounted upon said rock-shaft, provided with elongated openings adapted to be engaged by the studs upon the said bars, and means whereby the said bars may be reciprocated in such a manner that while the driving-shaft makes one revolution, one bar is moved outward and the other inward, and means for reversing the order of rotation of said driving-shaft, substantially as described.

7. The combination with a driving-shaft mounted transversely of a ship, bars mounted in grooves running longitudinally of said driving-shaft, and studs upon the ends of said bars, a rock-shaft mounted transversely in the end of said driving-shaft, and propeller-blades mounted upon the ends of said rock-shaft, means for reciprocating said bars, and means for communicating the motion of said bars to said rock-shaft to cause said propeller-blades to partially rotate, substantially as described.

8. The combination with a driving-shaft, mounted transversely of a ship, bars mounted in grooves running longitudinally of said driving-shaft, and studs upon the ends of said bars, a rock-shaft mounted transversely through the end of said driving-shaft, propeller-blades mounted upon the ends of said rock-shaft, a socket through which said driving-shaft passes, provided with a cam-groove which is adapted to be engaged by the studs upon one end of said bars, and means for

communicating motion from said bars to said rock-shaft, substantially as described.

5 9. The combination with a driving-shaft mounted transversely of a ship, bars mounted in grooves running longitudinally of said driving-shaft, and studs upon the ends of said bars, a rock-shaft mounted transversely through the end of said driving-shaft, propeller-blades mounted upon the ends of said
10 rock-shaft, a socket revolubly mounted upon a bearing, said socket being provided with means for reciprocating said bars, and means for communicating the motion from said bars to said rock-shaft, substantially as described.

15 10. The combination with a driving-shaft mounted transversely of a ship, bars mounted in grooves running longitudinally of said driv-

ing-shaft, and studs upon the ends of said bars, a rock-shaft mounted transversely through the end of said driving-shaft, propeller-blades mounted upon the ends of said rock-shaft, a socket revolubly mounted upon a bearing, means for rotating said socket one-half a revolution, means carried by said socket for reciprocating said bars, and means for communicating the motion from said bars to said rock-shaft, substantially as described. 20 25

In testimony whereof I affix my signature in presence of two witnesses.

ANTO. VOLTOR.

Witnesses:

FRANCISCO CATARINEU GUARDIOLA,
CONSTANTINE LUPEZ CID.