



(86) Date de dépôt PCT/PCT Filing Date: 2012/07/18
 (87) Date publication PCT/PCT Publication Date: 2013/02/07
 (85) Entrée phase nationale/National Entry: 2014/01/07
 (86) N° demande PCT/PCT Application No.: US 2012/047163
 (87) N° publication PCT/PCT Publication No.: 2013/019409
 (30) Priorité/Priority: 2011/07/29 (US13/194,271)

(51) Cl.Int./Int.Cl. *C23F 11/00* (2006.01),
C23C 26/00 (2006.01)
 (71) Demandeur/Applicant:
BAKER HUGHES INCORPORATED, US
 (72) Inventeurs/Inventors:
MAZYAR, OLEG A., US;
JOHNSON, MICHAEL, US;
GUEST, RANDALL, US;
CARREJO, NICHOLAS, US;
FURLAN, WAYNE, US;
GAUDETTE, SEAN, US;
XU, ZHIYUE, US
 (74) Agent: SIM & MCBURNEY

(54) Titre : PROCEDE PERMETTANT DE REGULER LA VITESSE DE CORROSION DES PARTICULES D'ALLIAGE,
PARTICULE D'ALLIAGE AYANT UNE VITESSE DE CORROSION REGULEE ET ARTICLES COMPRENANT LA
PARTICULE
 (54) Title: METHOD OF CONTROLLING THE CORROSION RATE OF ALLOY PARTICLES, ALLOY PARTICLE WITH
CONTROLLED CORROSION RATE, AND ARTICLES COMPRISING THE PARTICLE

FIG. 1A

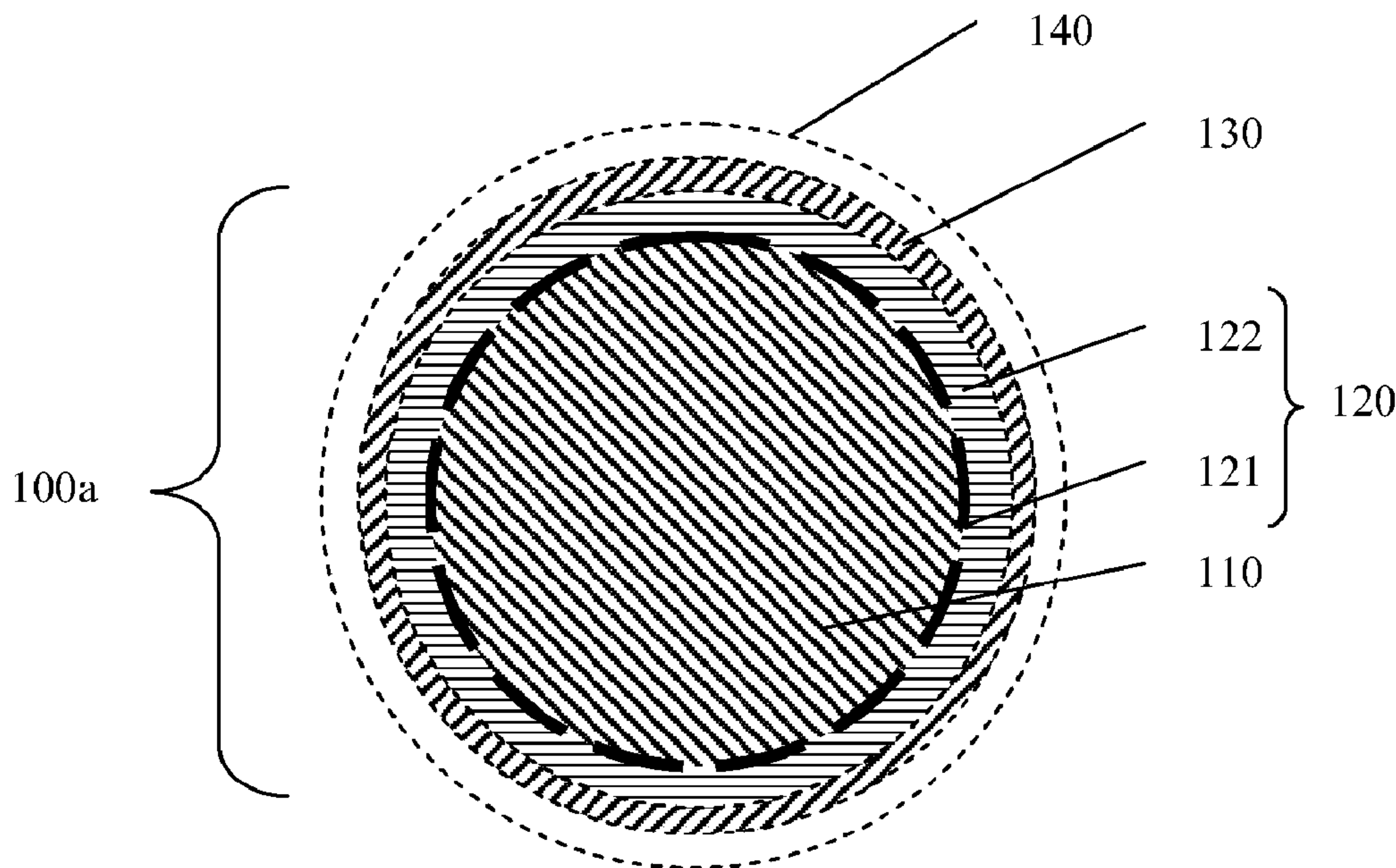

(57) Abrégé/Abstract:

A composite particle comprises a core, a shielding layer deposited on the core, and further comprising an interlayer region formed at an interface of the shielding layer and the core, the interlayer region having a reactivity less than that of the core, and the shielding layer having a reactivity less than that of the interlayer region, a metallic layer not identical to the shielding layer and deposited on the shielding layer, the metallic layer having a reactivity less than that of the core, and optionally, an adhesion metal layer deposited on the metallic layer.



(12) INTERNATIONAL APPLICATION PUBLISHED UNDER THE PATENT COOPERATION TREATY (PCT)

(19) World Intellectual Property
Organization
International Bureau(43) International Publication Date
7 February 2013 (07.02.2013)(10) International Publication Number
WO 2013/019409 A3

- (51) **International Patent Classification:**
C23F 11/00 (2006.01) C23C 26/00 (2006.01)
- (21) **International Application Number:**
PCT/US2012/047163
- (22) **International Filing Date:**
18 July 2012 (18.07.2012)
- (25) **Filing Language:** English
- (26) **Publication Language:** English
- (30) **Priority Data:**
13/194,271 29 July 2011 (29.07.2011) US
- (71) **Applicant (for all designated States except US):** **BAKER HUGHES INCORPORATED** [US/US]; P.O. Box 4740, Houston, Texas 77210-4740 (US).
- (72) **Inventors; and**
- (75) **Inventors/Applicants (for US only):** **MAZYAR, Oleg A.** [UA/US]; 12410 W Little York Road, Apt. 722, Houston, Texas 77041 (US). **JOHNSON, Michael** [US/US]; 6230 Clear Canyon Drive, Katy, Texas 77450 (US). **GUEST, Randall** [US/US]; 6511 Allentown Drive, Spring, Texas 77389 (US). **CARREJO, Nicholas** [US/US]; 26419 Longview Creek Drive, Katy, Texas 77494 (US). **FURLAN, Wayne** [US/US]; 19126 Cove Forest Lane, Cypress, Texas 77433 (US). **GAUDETTE, Sean** [US/US]; 23322 Dunhill Court, Katy, Texas 77494 (US). **XU, Zhiyue** [US/US]; 18709 N. Bee Cave Springs Circle, Cypress, Texas 77433 (US).
- (81) **Designated States (unless otherwise indicated, for every kind of national protection available):** AE, AG, AL, AM, AO, AT, AU, AZ, BA, BB, BG, BH, BR, BW, BY, BZ, CA, CH, CL, CN, CO, CR, CU, CZ, DE, DK, DM, DO, DZ, EC, EE, EG, ES, FI, GB, GD, GE, GH, GM, GT, HN, HR, HU, ID, IL, IN, IS, JP, KE, KG, KM, KN, KP, KR, KZ, LA, LC, LK, LR, LS, LT, LU, LY, MA, MD, ME, MG, MK, MN, MW, MX, MY, MZ, NA, NG, NI, NO, NZ, OM, PE, PG, PH, PL, PT, QA, RO, RS, RU, RW, SC, SD, SE, SG, SK, SL, SM, ST, SV, SY, TH, TJ, TM, TN, TR, TT, TZ, UA, UG, US, UZ, VC, VN, ZA, ZM, ZW.
- (84) **Designated States (unless otherwise indicated, for every kind of regional protection available):** ARIPO (BW, GH, GM, KE, LR, LS, MW, MZ, NA, RW, SD, SL, SZ, TZ, UG, ZM, ZW), Eurasian (AM, AZ, BY, KG, KZ, RU, TJ, TM), European (AL, AT, BE, BG, CH, CY, CZ, DE, DK, EE, ES, FI, FR, GB, GR, HR, HU, IE, IS, IT, LT, LU, LV, MC, MK, MT, NL, NO, PL, PT, RO, RS, SE, SI, SK, SM, TR), OAPI (BF, BJ, CF, CG, CI, CM, GA, GN, GQ, GW, ML, MR, NE, SN, TD, TG).
- Declarations under Rule 4.17:**
- as to applicant's entitlement to apply for and be granted a patent (Rule 4.17(ii))
 - as to the applicant's entitlement to claim the priority of the earlier application (Rule 4.17(iii))
- Published:**
- with international search report (Art. 21(3))

[Continued on next page]

(54) **Title:** METHOD OF CONTROLLING THE CORROSION RATE OF ALLOY PARTICLES, ALLOY PARTICLE WITH CONTROLLED CORROSION RATE, AND ARTICLES COMPRISING THE PARTICLE

FIG. 1A

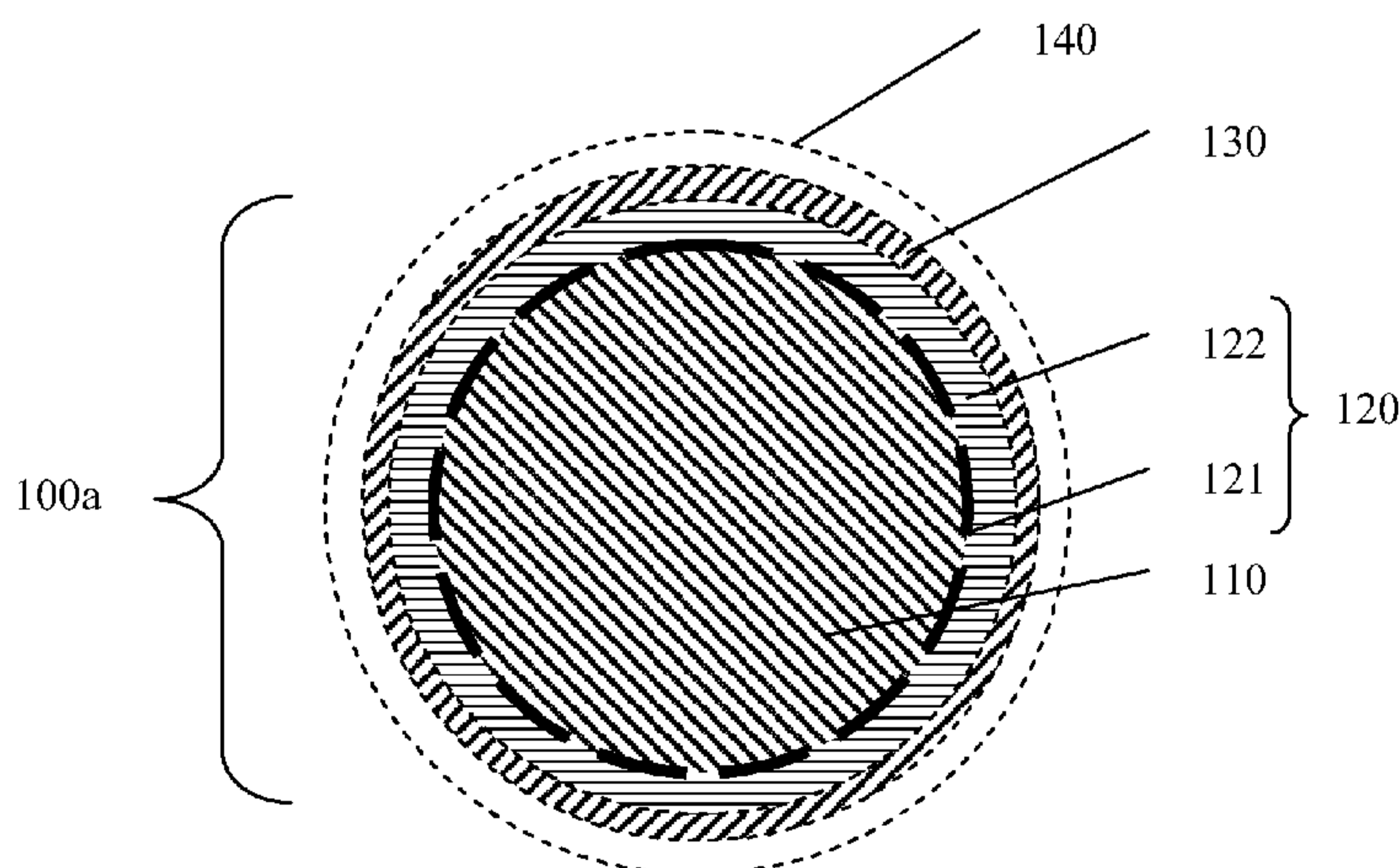

(57) **Abstract:** A composite particle comprises a core, a shielding layer deposited on the core, and further comprising an interlayer region formed at an interface of the shielding layer and the core, the interlayer region having a reactivity less than that of the core, and the shielding layer having a reactivity less than that of the interlayer region, a metallic layer not identical to the shielding layer and deposited on the shielding layer, the metallic layer having a reactivity less than that of the core, and optionally, an adhesion metal layer deposited on the metallic layer.

WO 2013/019409 A3

WO 2013/019409 A3 

(88) Date of publication of the international search report:
11 July 2013

METHOD OF CONTROLLING THE CORROSION RATE OF ALLOY PARTICLES,
ALLOY PARTICLE WITH CONTROLLED CORROSION RATE, AND ARTICLES
COMPRISING THE PARTICLE

CROSS REFERENCE TO RELATED APPLICATIONS

This application claims the benefit of U.S. Application No. 13/194271, filed on July 29, 2011, which is incorporated herein by reference in its entirety.

BACKGROUND

[0001] Certain downhole operations involve placement of elements in a downhole environment, where the element performs its function, and is then removed. For example, elements such as ball/ball seat assemblies and fracture (frac) plugs are downhole elements used to seal off lower zones in a borehole in order to carry out a hydraulic fracturing process (also referred to in the art as “fracking”) to break up different zones of reservoir rock. After the fracking operation, the ball/ball seat or plugs are then removed to allow fluid flow to or from the fractured rock.

[0002] Balls and/or ball seats, and frac plugs, may be formed of a corrodible material so that they need not be physically removed intact from the downhole environment. In this way, when the operation involving the ball/ball seat or frac plug is completed, the ball, ball seat, and/or frac plug corrodes away. Otherwise, the downhole article may have to remain in the hole for a longer period than is necessary for the operation.

[0003] To facilitate removal, such elements may be formed of a material that reacts with the ambient downhole environment so that they need not be physically removed by, for example, a mechanical operation, but may instead corrode or dissolve under downhole conditions. However, while corrosion rates of, for example, an alloy used to prepare a corrodible article can be controlled by adjusting alloy composition, an alternative way of controlling the corrosion rate of a downhole article is desirable.

[0004] Corrodible materials may include those having a high activity on the saltwater galvanic series, such as a magnesium alloy adjusted for corrosion rate. It has been found that adjusting the amount of trace contaminants in a magnesium alloy can have a significant impact on the corrosion rate of such alloys (Song, G. and Atrens, A., “Understanding Magnesium Corrosion: A Framework for Improved Alloy Performance,” *Adv. Eng. Mater.* 2003, 5(12) pp. 837-858). For example, metals such as nickel, iron, copper, calcium, etc., may be added to magnesium to increase the corrosion rate and other metals such as

zirconium, yttrium, etc. may be added to decrease the corrosion rate. Balancing the amounts of such additives to achieve a desired bulk corrosion rate can in this way control overall corrosion of articles made from the alloy; however, such an approach requires preparation of multiple batches of alloy, requiring high batch-to-batch reproducibility and precise, reproducible control of metal additives or contaminants in the alloy.

[0005] There accordingly remains a need for controlling the overall corrosion rate of magnesium alloys for use in downhole articles without need for fine adjustment of alloy composition and with improved corrosion control.

SUMMARY

[0006] The above and other deficiencies of the prior art are overcome by, in an embodiment, a composite particle comprising a core, a shielding layer deposited on the core, and further comprising an interlayer region formed at an interface of the shielding layer and the core, the interlayer region having a reactivity less than that of the core, and the shielding layer having a reactivity less than that of the interlayer region, a metallic layer not identical to the shielding layer and deposited on the shielding layer, the metallic layer having a reactivity less than that of the core, and optionally, an adhesion metal layer deposited on the metallic layer.

[0007] In another embodiment, a composite particle comprises a magnesium-aluminum alloy core, a shielding layer comprising an aluminum-containing layer deposited on the core, and further comprising an interlayer region comprising α -Mg and γ -Mg₁₇Al₁₂ formed at the interface between the magnesium alloy core and the aluminum-containing layer, and further comprising inclusions of alumina, magnesia, or a combination comprising at least one of these oxides, a metallic layer deposited on the shielding layer, the metallic layer comprising Ni, Fe, Cu, Co, W, alloys thereof, or a combination comprising at least one of the foregoing, an aluminum-containing shielding layer deposited on the metallic layer, and optionally, an aluminum-containing adhesion metal layer, wherein the interlayer region, shielding layer, metallic layer, and optional adhesion metal layer are inter-dispersed with each other.

[0008] In another embodiment, a method of adjusting corrosion rate in an aqueous electrolyte is disclosed for a composite particle having a core, a shielding layer deposited on the core, and further comprising an interlayer region formed at an interface of the shielding layer and the core, the interlayer region having a reactivity less than that of the core, and the

shielding layer having a reactivity less than that of the interlayer region, a metallic layer not identical to the shielding layer and deposited on the shielding layer, the metallic layer having a reactivity less than that of the core, and optionally, an adhesion metal layer deposited on the metallic layer, the method comprising selecting the metallic layer such that the lower the reactivity of the metallic layer is relative to the shielding layer, the greater the corrosion rate, and selecting the amount, thickness, or both amounts and thicknesses of the shielding layer and metallic layer such that the less the amount, thickness, or both amount and thickness of the shielding layer relative to those of the metallic layer, the greater the corrosion rate.

BRIEF DESCRIPTION OF THE DRAWINGS

[0009] Referring now to the drawings wherein like elements are numbered alike in the several Figures:

[0010] FIG. 1 shows a cross-sectional view of a composite particle 100a having a multilayer structure (FIG. 1A) and a cross-sectional view of a composite particle 100b having an inter-dispersed layer (FIG. 1B);

[0011] FIG. 2 shows a cross-sectional view of a composite particle 200a having a multilayer structure (FIG. 2A) and a cross-sectional view of a composite particle 200b having an inter-dispersed layer (FIG. 2B); and

[0012] FIG. 3 shows a cross-sectional view of an exemplary corrodible downhole article 300 prepared from the composite particles 310.

DETAILED DESCRIPTION OF THE INVENTION

[0013] Disclosed herein is a composite particle useful for fabricating a corrodible article. The composite particle has multilayered structure of a core of a high reactivity material, such as magnesium or a magnesium alloy, coated a shielding layer such as for example, aluminum. At the interface of the shielding layer and the core, an intermetallic phase can form, such as a crystalline metallic compound of magnesium and aluminum, and present in discontinuous regions. The shielding layer, which includes the intermetallic regions, has a layer of a noble material with a lower reactivity (i.e., more noble than the shielding layer, though comparable in reactivity to the intermetallic phase) disposed on it. An additional layer of an adhesive metal, for example, aluminum, can be disposed over the noble material layer, to provide adhesion between particles upon molding. The interlayer region, shielding layer, noble material layer (referred to herein as the “metallic layer” where the noble material is a metal), and optional adhesion layer are believed to be inter-dispersed with

each other, and form a compositionally varied outer shell which is also inter-dispersed with the core.

[0014] The noble material layer, which has a lower reactivity relative to the core material, acts as a cathode, whereas the core, made of a metal such as magnesium which is more reactive than the noble metal layer, is anodic relative to the noble metal layer. The shielding layer, which includes the intermetallic phase, is also cathodic relative to the core, but anodic relative to the noble metal layer. A galvanic discharge cycle (e.g., corrosion) occurs between the relatively anodic and relatively cathodic materials in the presence of an electrolyte. By adjusting the composition of the noble metal layer relative to the core and shielding layers, and by adjusting the amounts and/or thicknesses of the shielding and noble metal layers, the corrosion rate of the composite particle is adjusted.

[0015] The composite particles are formed into articles by compressing and shaping the particles using, for example, cold molding followed by forging.

[0016] The core includes any material suitable for use in a downhole environment, provided the core is corrodible in the downhole environment relative to a second material having a different reactivity. In an embodiment, the composite particle thus includes a magnesium-containing core. A magnesium-containing core includes any such alloy which is corrodible in a corrosive environment including those typically encountered downhole, such as an aqueous environment which includes salt (i.e., brine), or an acidic or corrosive agent such as hydrogen sulfide, hydrochloric acid, or other such corrosive agents. Magnesium alloys suitable for use include alloys of magnesium (Mg) with aluminum (Al), cadmium (Cd), calcium (Ca), cobalt (Co), copper (Cu), iron (Fe), manganese (Mn), nickel (Ni), silicon (Si), silver (Ag), strontium (Sr), thorium (Th), zinc (Zn), zirconium (Zr), or a combination comprising at least one of these elements. Particularly useful alloys include magnesium alloy particles including those prepared from magnesium alloyed with Ni, W, Co, Cu, Fe, or other metals. Alloying or trace elements can be included in varying amounts to adjust the corrosion rate of the magnesium. For example, four of these elements (cadmium, calcium, silver, and zinc) have mild-to-moderate accelerating effects on corrosion rates, whereas four others (copper, cobalt, iron, and nickel) have a still greater accelerating effect on corrosion. Exemplary commercially available magnesium alloys and which include different combinations of the above alloying elements to achieve different degrees of corrosion resistance include but are not limited to, for example, magnesium alloyed with aluminum, strontium, and manganese such as AJ62, AJ50x, AJ51x, and AJ52x alloys, and magnesium alloyed with aluminum, zinc, and manganese which include AZ91A-E alloys.

[0017] It will be appreciated that alloys having corrosion rates greater than those of the above exemplary alloys are contemplated as being useful herein. For example, nickel has been found to be useful in decreasing the corrosion resistance (i.e., increases the corrosion rate) of magnesium alloys when included in amounts of less than or equal to about 0.5 wt%, specifically less than or equal to about 0.4 wt%, and more specifically less than or equal to about 0.3 wt%, to provide a useful corrosion rate for the corrodible downhole article. In another embodiment, the magnesium-containing core comprises a magnesium-aluminum alloy.

[0018] Particle sizes for the magnesium alloy cores may be from about 50 to about 150 micrometers (μm), more specifically about 60 to about 140 μm , and still more specifically about 70 to about 130 μm . Useful magnesium alloys may include combinations of the above elements and/or contaminants sufficient to achieve a corrosion rate for the magnesium alloy core of about 0.1 to about 20 $\text{mg}/\text{cm}^2/\text{hour}$, specifically about 1 to about 15 $\text{mg}/\text{cm}^2/\text{hour}$ using aqueous 3 wt% KCl solution at 200°F (93°C).

[0019] The composite particle includes a shielding layer. The shielding layer is formed by depositing on the core, a material having a lower reactivity than that of the core. In an exemplary embodiment, the shielding layer is an aluminum-containing layer deposited on the core. In an embodiment, the core is a magnesium alloy core and the shielding layer is an aluminum-containing layer. As used herein “on” and “deposited on” mean that a layer may or may not be in direct contact with, the underlying surface to which the layer is applied, unless otherwise specified as by stating that the layers are at least partially in contact. It will be further understood that “deposited” and “depositing,” when used in with respect to a method, indicates the action of deposition, whereas “deposited” when used in the context of a composition or article, merely indicates the juxtaposition of the layer with respect to the substrate and does not indicate a process of deposition. The shielding layer further comprises an interlayer region formed at the interface of the core and shielding layer, which is compositionally derived from the core and shielding layers. In an embodiment, the interlayer region forms at the boundary of a magnesium-containing core and an aluminum-containing shielding layer, and the interlayer region comprises an intermetallic compound. For example, magnesium-aluminum alloys include an α -Mg phase, and in addition, a γ - $\text{Mg}_{17}\text{Al}_{12}$ intermetallic phase which accumulates at the grain boundaries within the Mg-Al alloy. The intermetallic γ - $\text{Mg}_{17}\text{Al}_{12}$ phase is generally present in amounts of less than 30 wt% of the Mg-Al alloy. Depending upon the composition, additional phases can also be present,

including solid solution Al, and other intermetallic phases such as β -Mg₂Al₃. Upon deposition of the aluminum-containing shielding layer, the γ -Mg₁₇Al₁₂ phase forms and accumulates as well at the interface of the shielding layer and the Mg-containing core. Thermal treatment can accelerate the formation of the interlayer region. For example, heating at temperatures less than the eutectic point (e.g., less than or equal to about 450°C, depending on the alloy composition, and as long as the eutectic point is not exceeded) for about 15 minutes can form an intermetallic phase at the interface of the Mg-containing core and the Al-containing layer. The composite particle thus includes, as part of the interlayer region, the intermetallic compound γ -Mg₁₇Al₁₂. The interlayer region forms over the entire contacting area of the Mg-containing core and the Al-containing layer, or a portion of the contacting areas. Deposition method and any heat treating can be adjusted so that the intermetallic phase intervenes between a portion of contacting surfaces of the Mg alloy core and the Al-containing layer. The shielding layer further includes an oxide of one or more of the metals of which the core and/or shielding layers are comprised. For example, where the core comprises magnesium or a magnesium-aluminum alloy, and the shielding layer comprises aluminum, the shielding layer optionally includes oxides of magnesium (such as magnesia), aluminum (such as alumina), or a combination comprising at least one of the foregoing.

[0020] The composite particle further includes a metallic layer not identical to the shielding layer and deposited on the shielding layer. The metallic layer has a lower reactivity relative to the core, based on the saltwater galvanic series from lower reactivity (i.e., more noble metals) to high reactivity (i.e., less noble metals). In an embodiment, the metal(s) used for the metallic layer allow for the formation of hydrogen when used as a cathode in an electrochemical cell. The metallic layer thus comprises a group 6-11 transition metal. Specifically, the group 6-11 transition metal includes Ni, Fe, Cu, Co, W, alloys thereof, or a combination comprising at least one of the foregoing.

[0021] The composite particle optionally includes an adhesion layer deposited on the metallic layer. The adhesion layer comprises a material which promotes adhesion between the composite particles. An exemplary adhesion layer includes aluminum or an aluminum alloy. Upon compressing and forging of the adhesion layer-coated composite particles to form a molded article, the particles bind to one another through interparticle contact via the material of the adhesion layer, to further provide mechanical strength to the article.

[0022] The layers (shielding layer, metallic layer, and optional adhesion layer) may each have an average thickness of about 0.05 to about 0.15 μm , and specifically about 0.07 to about 0.13 μm . In an embodiment, each layer does not completely cover the underlying layer, and the layer coverage is thus discontinuous. Furthermore, where the layers are “on” one another, interstitial spaces at the interfaces of the layers may be present. In an embodiment, the interlayer region, shielding layer, metallic layer, and optional adhesion metal layer are inter-dispersed with each other. As used herein, “inter-dispersed” mean that two or more adjacent layers interpenetrate into or through each other in intimate admixture, where it will be appreciated that two (or more) inter-dispersed layers have, on average, a compositional gradient due to the interpenetration of one layer into the adjacent layer.

[0023] The core and shielding layer, shielding layer and metallic layer, and metallic layer and optional adhesion layer, are each thus in mutual partial contact, and are inter-dispersed, such that components of the core, the shielding layer, and the metallic layer are present at the exposed surface of the composite particle.

[0024] In an embodiment, the composite particles have a corrosion rate of about 0.1 to about 20 $\text{mg}/\text{cm}^2/\text{hour}$, specifically about 1 to about 15 $\text{mg}/\text{cm}^2/\text{hour}$ using an aqueous 3 wt% KCl solution at 200°F (93°C).

[0025] In a specific embodiment, the shielding layer is an aluminum-containing layer, and the core is a magnesium-containing core. In an embodiment, the shielding layer comprises aluminum. In another embodiment, the shielding layer further comprises, in addition to aluminum, inclusions of alumina, magnesia, or a combination comprising at least one of these oxides. The shielding layer further includes an interlayer region formed at the interface between the magnesium alloy core and the first aluminum-containing layer. In an embodiment, the interlayer region comprises $\gamma\text{-Mg}_{17}\text{Al}_{12}$.

[0026] Also in a specific embodiment, the metallic layer comprises a group 6-11 transition metal on the shielding layer. The group 6-11 transition metal includes Ni, Fe, Cu, Co, W, alloys thereof, or a combination comprising at least one of the foregoing.

[0027] Optionally, in a specific embodiment, the adhesion layer is an aluminum-containing layer deposited on the metallic layer.

[0028] Deposition of the shielding, metallic, and adhesion layers on the core is not particularly limited. Where either or both of the shielding and optional adhesion layers includes aluminum or an aluminum alloy, uniformly depositing the aluminum layer(s) on a magnesium alloy core particle is accomplished in one exemplary embodiment by

decomposition of an organometallic compound, such as triethylaluminum (having a boiling point of 128-130°C at 50 mm Hg), after introducing the organometallic compound into a fluidized bed reactor containing the magnesium alloy core particles to deposit the shielding layer, or the introducing the organometallic compound into a reactor containing magnesium alloy core/shielding layer/metallic layer particles to deposit the adhesion layer. The interlayer region, which in this case includes an intermetallic compound such as $\gamma\text{-Mg}_{17}\text{Al}_{12}$, further forms at the interface of the Mg alloy core and the shielding layer by a thermal treatment, such as sintering and/or annealing, and/or forging of an article molded from the composite particles, at a temperature below the melting point of all or part of the composite particle.

[0029] Similarly, depositing a uniform metallic layer is also not particularly limited, and may be accomplished by, for example, decomposition of an organometallic compound (such as nickel carbonyl where the metallic layer is nickel) after introducing the organometallic compound into a fluidized bed reactor containing the magnesium alloy core particles coated with the shielding layer.

[0030] The core can also be coated with materials for the shielding layer, metallic layer, and optional adhesion layer using a physical mixing method. For example, the core can be admixed with one or more components of the shielding layer, metallic layer, and optional adhesion layer by cryo-milling, ball milling, or the like. In this way, the shielding, metallic layer and adhesion layer components can be included sequentially, or components for two or all three layers included simultaneously. Combinations of deposition methods including vapor phase deposition and physical methods can also be used to provide the composite particles. Where all components are included by physical mixing simultaneously, it will be appreciated that a single layer is formed which is a composite of the shielding layer, metallic layer, and adhesion layer components.

[0031] In another embodiment, the core comprises an inner core of a first core material and an outer core of a second core material, the inner core material having a lower reactivity than that of the outer core. The inner core is any material useful for depositing thereon a high reactivity material such as magnesium, without limitation. The inner core can thus be any suitable, low reactivity material, such as a 6-11 transition metal including Ni, Fe, Cu, Co, W, alloys thereof, or a combination comprising at least one of the foregoing; a metal oxide such as alumina, silica, silicates, iron oxides, titania, tungstates, and the like; a polymer including a phenolic polymer; ceramics; glasses; or other such materials. In an exemplary

embodiment, the inner core comprises an aluminum alloy, nickel, iron, alumina, titania or silica, and the outer core comprises magnesium or a magnesium alloy as described hereinabove. The outer core is deposited on the inner core using any suitable deposition method such as physical vapor deposition (PVD) of the metallic magnesium or magnesium alloy in a fluidized bed reactor. The core structure having inner and outer cores is then coated with shielding layer, metallic layer, and optional adhesion layer as described above to form the composite particle.

[0032] The composite particle generally has a particle size of from about 50 to about 150 micrometers (μm), and more specifically about 60 to about 140 μm .

[0033] In another embodiment, a method of adjusting corrosion rate of a composite particle, or article prepared therefrom, is disclosed. In an embodiment, adjusting is accomplished by either or both of selecting the composition of the metallic layer to have the desired reactivity, where the lower the reactivity of the metallic layer relative to the shielding layer (and by definition, to both the core and interlayer region), the faster the corrosion rate; and conversely, the higher the reactivity of the metallic layer relative to the shielding layer, the slower the corrosion rate. Alternatively or in addition, in an embodiment, adjusting is accomplished by increasing the amount and/or thickness of the shielding layer for any given amount and/or thickness of metallic layer. It will further be appreciated that additional control of the corrosion rate is accomplished by the degree of inter-dispersion of the core, interlayer region, shielding layer, and metallic layer, where the more highly inter-dispersed these layers are, the greater the corrosion rate, and conversely, the less inter-dispersed the layers, the slower the corrosion rate. Thus, amount and thickness as used herein are related in that the higher the amount of a layer, expressed as weight percent based on the weight of the composite particle, the greater the thickness.

[0034] The surface of the composite particles includes both anodic and cathodic regions of the inter-dispersed layers. It will be understood that “anodic regions” and “cathodic regions” are relative terms, based on the relative reactivity of the inter-dispersed materials. For example as discussed above, magnesium (from the core) is anodic relative to the cathodic intermetallic compound of the interlayer region ($\gamma\text{-Mg}_{17}\text{Al}_{12}$) and cathodic aluminum from the interlayer region/shielding layer, and anodic relative to nickel from the cathodic metallic layer. Similarly, intermetallic compound ($\gamma\text{-Mg}_{17}\text{Al}_{12}$) is anodic relative to cathodic aluminum from the shielding layer, and anodic relative to nickel from the cathodic

metallic layer; and aluminum from the shielding layer is anodic relative to nickel from the metallic layer.

[0035] In this way, upon exposure of the surface of the composite particle (and any article made from the composite particles) to an electrolyte, multiple localized corrosion mechanisms take place in which reversal of anodic and cathodic regions occur. For example, after exposed anodic core material (such as magnesium) is corroded, a previously cathodic material (such as intermetallic compound or aluminum in the shielding layer) becomes anodic and is corroded by interaction with the more cathodic metallic layer (e.g., which includes nickel, etc.). As the surface corrodes away and new, more anodic core material such as magnesium is exposed, the situation again reverses and the aluminum or intermetallic compound becomes cathodic toward the core material.

[0036] As corrosion advances in localized regions on the surface between anodic and cathodic regions in the presence of an electrolyte fluid (water, brine, etc.), these regions, referred to herein as micro-cells, can corrode outward over the surface of the composite particle and link to other micro-cells to form larger corrosion regions, which in turn can link to other corrosion regions, etc., as further anodic materials such as magnesium (from the core) or intermetallic γ -Mg₁₇Al₁₂ (from the interlayer region/shielding layer) is exposed. After these regions corrode, new, underlying anodic materials from the core are exposed to the electrolyte. Upon corroding, these inter-dispersed layers can thus become permeable to the electrolyte fluid. This allows percolation of electrolytic fluids into the corroding surface to penetrate and undermine the layers, and the process repeats until the corrodible materials are consumed. It will be appreciated that the presence of metal oxides at the core/shielding layer interface also decreases the corrosion rate of the core at the interface by acting as an inert barrier, and thus affects the relative anodic/cathodic character of the micro-cell (for example, where alumina and/or magnesia are present between a magnesium core and the intermetallic compound, the intermetallic compound is insulated from the core and will be anodic relative to the metallic layer). In this way, the presence of inclusions of metal oxides affects the overall corrosion rate of the composite particle.

[0037] Where the core comprises an inner and outer core in which the outer core is anodic, corrosion advances until only the inner core remains. The inner core thus exposed no longer has the structural integrity and cohesiveness of the composite particle, and disperses into the surrounding fluid as a suspension of particles, and can be removed in this way.

[0038] Thus, in an embodiment, a method of adjusting corrosion rate in a composite particle includes selecting the metallic layer such that the lower the reactivity of the metallic layer is relative to the shielding layer, the greater the corrosion rate. In another embodiment, a method of adjusting corrosion rate in a composite particle includes selecting the amount, thickness, or both amounts and thicknesses of the shielding layer and the metallic layer such that the less the amount, thickness, or both amount and thickness of the shielding layer are relative to those of the metallic layer, the greater the corrosion rate. The interlayer region, shielding layer, metallic layer, and optional adhesion metal layer being inter-dispersed with each other, and have compositions as discussed above.

[0039] In another embodiment, an article comprises the composite particles which may be provided as a powder or other suitable form such as a pre-compressed pellet. Articles may be prepared from the composite particle by compressing or otherwise shaping the composite particles, to form an article having the appropriate shape. For example, the composite particles are molded or compressed into the desired shape by cold compression using an isostatic press at about 40 to about 80 ksi (about 275 to about 550 MPa), followed by forging or sintering and machining, to provide an article having the desired shape and dimensions. As disclosed herein, forging or sintering is carried out at a temperature below that of the melting point of the components.

[0040] Thus, a method of forming an article comprises molding the composite particles and forging the molded article.

[0041] The article so prepared is referred to as a controlled electrolytic material (CEM) article, and useful under downhole conditions. Articles include, for example a ball, a ball seat, a fracture plug, or other such downhole article. However, it should be understood that though these articles are disclosed, there are other uses for the composite particles in powder form. For example, the composite particles may be included in a matrix that is non-metallic, and may be applied to a surface as a coating, such as a paint, powder coating, etc., where a controlled electrolytic process occurs in the presence of water, and preferably, water plus an electrolyte. Such processes may include coatings for marine applications such as drill rigs, boat or ship hulls, undersea tools, or other such applications. Such an electrolytic material may provide a sacrificial layer to mitigate or prevent corrosion of an underlying metal layer, or may alternatively prevent adhesion of, for example, marine organisms to the underwater surface coated with the composite particles.

[0042] An exemplary use is described herein. FIG. 1 shows in schematic cross-section different structural variants of the composite particles 100a and 100b. In FIG. 1A, the

composite particle 100a includes a core 110; a shielding layer 120 which includes an intermetallic region 121 (heavy dashed line) and aluminum layer 122 surrounding the intermetallic region; a metallic layer 130, and optionally, a second aluminum layer 140 which functions as an adhesion layer. This adhesion layer 140 may be included to promote the adhesion of particles when compressed together to form a shaped article. It will be appreciated that the layers, while shown as discrete core-shell layers, can also be intermixed at the interfaces and/or the layers can be discontinuous on the surfaces to which they are applied, such that core 110 is actually in contact with shielding layer 120 and/or metallic layer 130 and/or adhesion layer 140.

[0043] In FIG 1B, composite particle 100b has a core 110 and an inter-dispersed layer 150 which includes the components of the interlayer region, shielding layer, metallic layer, and optional adhesion layer (not shown individually in FIG. 1B). It will be appreciated that such an inter-dispersed structure can derive from a discontinuous core-shell structure as described in FIG. 1A, and in which inter-dispersion is enhanced by thermal treatment (e.g., sintering); or the inter-dispersed structure can derive from a physical method of forming the particles (e.g., cryo- or ball-milling) or by including precursor materials for more than one layer into a fluidized bed reactor during layer formation. The inter-dispersed layer 150 is homogeneously inter-dispersed with the components of the different layers (interlayer region, shielding layer, metallic layer) equally distributed throughout inter-dispersed layer 150, or is non-uniformly distributed, for example, in a gradient where the composition changes from predominantly interlayer region composition at the interface of inter-dispersed layer 150 and core 110, to predominantly adhesion layer composition at the outer surface of inter-dispersed layer 150.

[0044] FIG. 2 shows, similar to FIG. 1, cross-sectional views of different structural variants of the composite particles 200a and 200b. In FIG. 2A, the composite particle 200a includes a core 210 comprising inner core 211 and outer core 212; a shielding layer 220 which includes an intermetallic region 221 (heavy dashed line) and aluminum layer 222 surrounding the intermetallic region; a metallic layer 230, and optionally, a second aluminum layer 240 which functions as an adhesion layer. As in FIG. 1A, it will be appreciated that the layers, while shown as discrete core-shell layers, can also be intermixed at the interfaces and/or the layers can be discontinuous on the surfaces to which they are applied.

[0045] In FIG 2B, composite particle 200b has a core 210 comprising inner core 211 and outer core 212 and an inter-dispersed layer 250 which includes the components of the interlayer region, shielding layer, metallic layer, and optional adhesion layer (not shown

individually in FIG. 2B). As in FIG. 1B, it will be appreciated that such an inter-dispersed structure can derive from a discontinuous core-shell structure, from milling to form the particles, or by including precursor materials for more than one layer into a fluidized bed reactor during layer formation. Also as in FIG. 1B, the composition of inter-dispersed layer 250 is homogeneously distributed, or is non-uniformly distributed, such as for example, in a gradient.

[0046] In FIG. 3, as an exemplary article, a ball 300 is shown. In FIG. 3, the ball 300 is composed of composite particles 310. During cold compacting to form ball 300, the powdered composite particles 310 are compressed into and shaped to form the spherical ball 300 with interstitial spaces 320, where the interstitial spaces 320 are further reduced in volume by forging and/or sintering to reduce free volume from about 20% after compacting to less than about 5%, specifically less than about 3%, and still more specifically less than about 1% after forging/sintering. When used in conjunction with a ball seat (not shown) and seated in the ball seat to prevent fluid flow past the ball/ball seat, ball 300 forms a downhole seal for isolating, for example, a fracture zone located below the ball/ball seat assembly.

[0047] While one or more embodiments have been shown and described, modifications and substitutions may be made thereto without departing from the spirit and scope of the invention. Accordingly, it is to be understood that the present invention has been described by way of illustration and not limitation.

[0048] All ranges disclosed herein are inclusive of the endpoints, and the endpoints are independently combinable with each other. The suffix “(s)” as used herein is intended to include both the singular and the plural of the term that it modifies, thereby including at least one of that term (e.g., the colorant(s) includes at least one colorant). “Optional” or “optionally” means that the subsequently described event or circumstance can or cannot occur, and that the description includes instances where the event occurs and instances where it does not. As used herein, “combination” is inclusive of blends, mixtures, alloys, reaction products, and the like. All references are incorporated herein by reference.

[0049] The use of the terms “a” and “an” and “the” and similar referents in the context of describing the invention (especially in the context of the following claims) are to be construed to cover both the singular and the plural, unless otherwise indicated herein or clearly contradicted by context. Further, it should further be noted that the terms “first,” “second,” and the like herein do not denote any order, quantity, or importance, but rather are used to distinguish one element from another. The modifier “about” used in connection with

a quantity is inclusive of the stated value and has the meaning dictated by the context (e.g., it includes the degree of error associated with measurement of the particular quantity).

CLAIMS

1. A composite particle, comprising:
 - a core,
 - a shielding layer deposited on the core, and further comprising an interlayer region formed at an interface of the shielding layer and the core, the interlayer region having a reactivity less than that of the core, and the shielding layer having a reactivity less than that of the interlayer region,
 - a metallic layer not identical to the shielding layer and deposited on the shielding layer, the metallic layer having a reactivity less than that of the core, and
 - optionally, an adhesion metal layer deposited on the metallic layer.
2. The composite particle of claim 1, wherein the core comprises magnesium, the shielding layer comprises aluminum and, optionally, oxides of aluminum, magnesium, or a combination comprising at least one of the foregoing, and the interlayer region comprises an intermetallic compound.
3. The composite particle of claim 2, wherein the intermetallic compound is γ - $\text{Mg}_{17}\text{Al}_{12}$.
4. The composite particle of claim 1, wherein the metallic layer comprises a group 6-11 transition metal.
5. The composite particle of claim 4, wherein the group 6-11 transition metal comprises Ni, Fe, Cu, Co, W, alloys thereof, or a combination comprising at least one of the foregoing.
6. The composite particle of claim 1, wherein the core comprises an inner core of a first core material and an outer core of a second core material, the inner core material having a lower activity than that of the outer core.
7. The composite particle of claim 1, wherein the inner core comprises aluminum, and the outer core comprises magnesium.
8. The composite particle of claim 1, wherein the core comprises a magnesium-aluminum alloy.
9. The composite particle of claim 1, wherein the core and shielding layer, shielding layer and metallic layer, and metallic layer and optional adhesion metal layer, are each in mutual partial contact.
10. The composite particle of claim 1, wherein the interlayer region, shielding layer, metallic layer, and optional adhesion metal layer are inter-dispersed with each other.

11. The composite particle of claim 1, wherein the shielding layer is cathodic relative to the core, and anodic relative to the metallic layer.

12. A composite particle, comprising:

a magnesium-aluminum alloy core,

a shielding layer comprising an aluminum-containing layer deposited on the core, further comprising an interlayer region comprising γ -Mg₁₇Al₁₂ formed at the interface between the magnesium alloy core and the aluminum-containing layer, and further comprising inclusions of alumina, magnesia, or a combination comprising at least one of these oxides,

a metallic layer deposited on the shielding layer, the metallic layer comprising Ni, Fe, Cu, Co, W, alloys thereof, or a combination comprising at least one of the foregoing,

an aluminum-containing shielding layer deposited on the metallic layer, and

optionally, an aluminum-containing adhesion metal layer,

wherein the interlayer region, shielding layer, metallic layer, and optional adhesion metal layer are inter-dispersed with each other.

13. A method of adjusting corrosion rate in an aqueous electrolyte of a composite particle having:

a core,

a shielding layer deposited on the core, and further comprising an interlayer region formed at an interface of the shielding layer and the core, the interlayer region having a reactivity less than that of the core, and the shielding layer having a reactivity less than that of the interlayer region,

a metallic layer not identical to the shielding layer and deposited on the shielding layer, the metallic layer having a reactivity less than that of the core, and

optionally, an adhesion metal layer deposited on the metallic layer:

the method comprising selecting the metallic layer such that the lower the activity of the metallic layer is relative to the shielding layer, the greater the corrosion rate, and

selecting the amount, thickness, or both amounts and thicknesses of the shielding layer and metallic layer such that the less the amount, thickness, or both amount and thickness of the shielding layer relative to those of the metallic layer, the greater the corrosion rate.

14. The method of claim 13, wherein the interlayer region, shielding layer, metallic layer, and optional adhesion metal layer are inter-dispersed with each other.

15. The method of claim 13, wherein the core comprises magnesium, the shielding layer comprises aluminum, and inclusions of alumina, magnesia, or a combination comprising at least one of the foregoing oxides, and the interlayer region comprises γ - $\text{Mg}_{17}\text{Al}_{12}$.

16. The method of claim 13, wherein the metallic layer comprises a group 6-11 transition metal.

17. The method of claim 16, wherein the metallic layer comprises Ni, Fe, Cu, Co, W, alloys thereof, or a combination comprising at least one of the foregoing.

18. A method of forming an article, comprising molding the composite particles of claim 1, and forging the molded article.

19. An article comprising the composite particles of claim 1.

20. The article of claim 19, wherein the article comprises a ball, ball seat, or fracture plug.

21. A coating comprising the composite particles of claim 1.

FIG. 1A

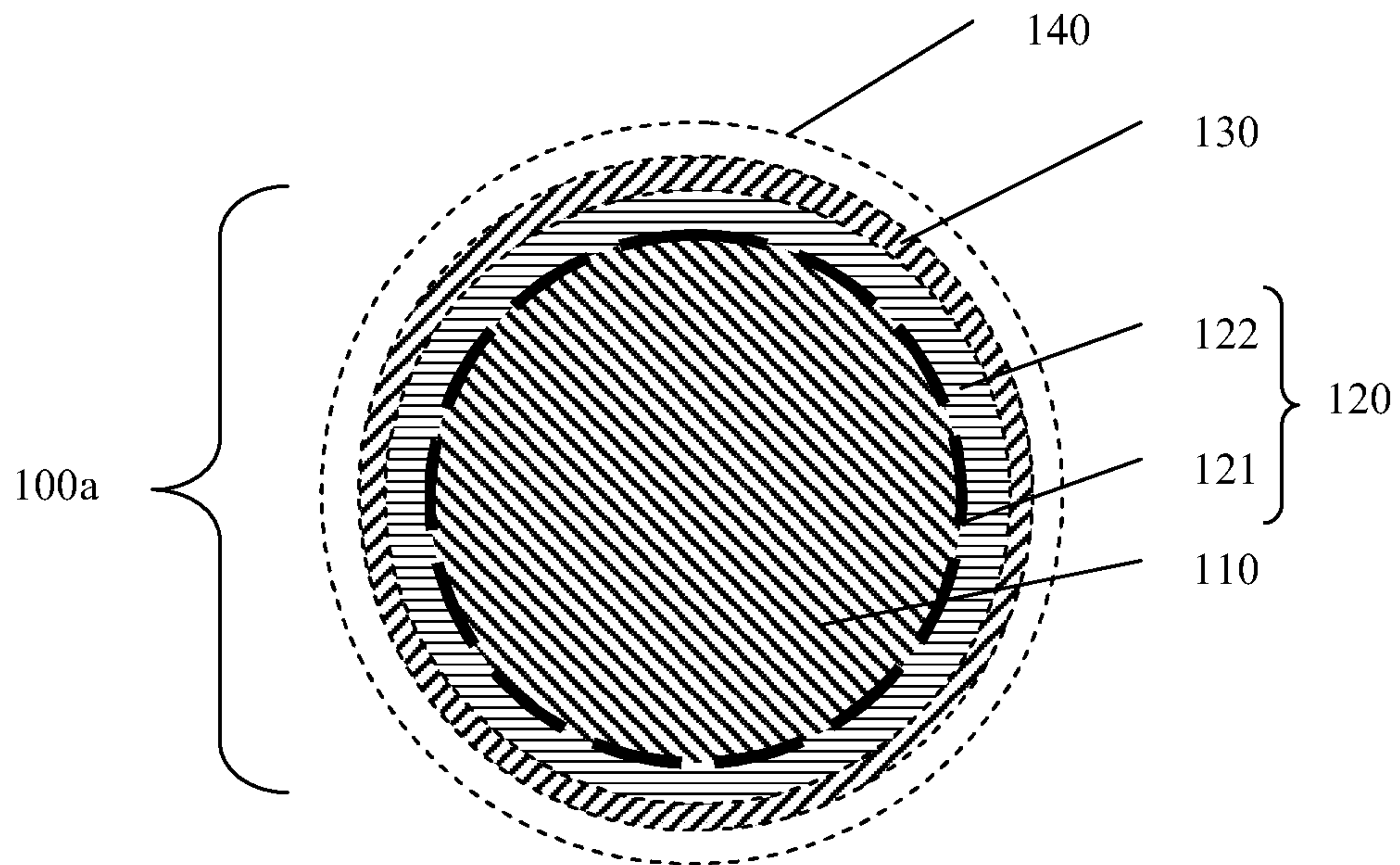

FIG. 1B

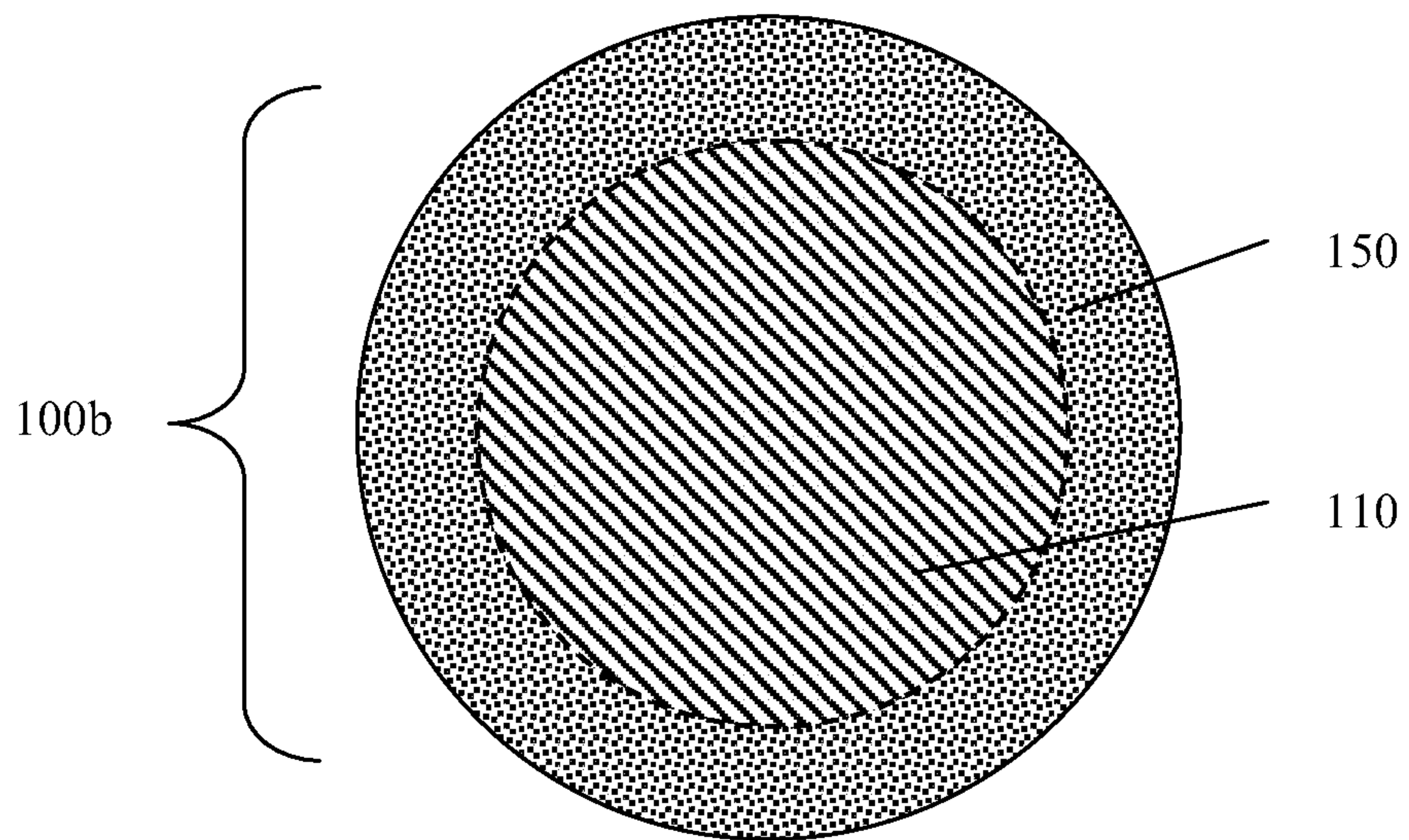

FIG. 2A

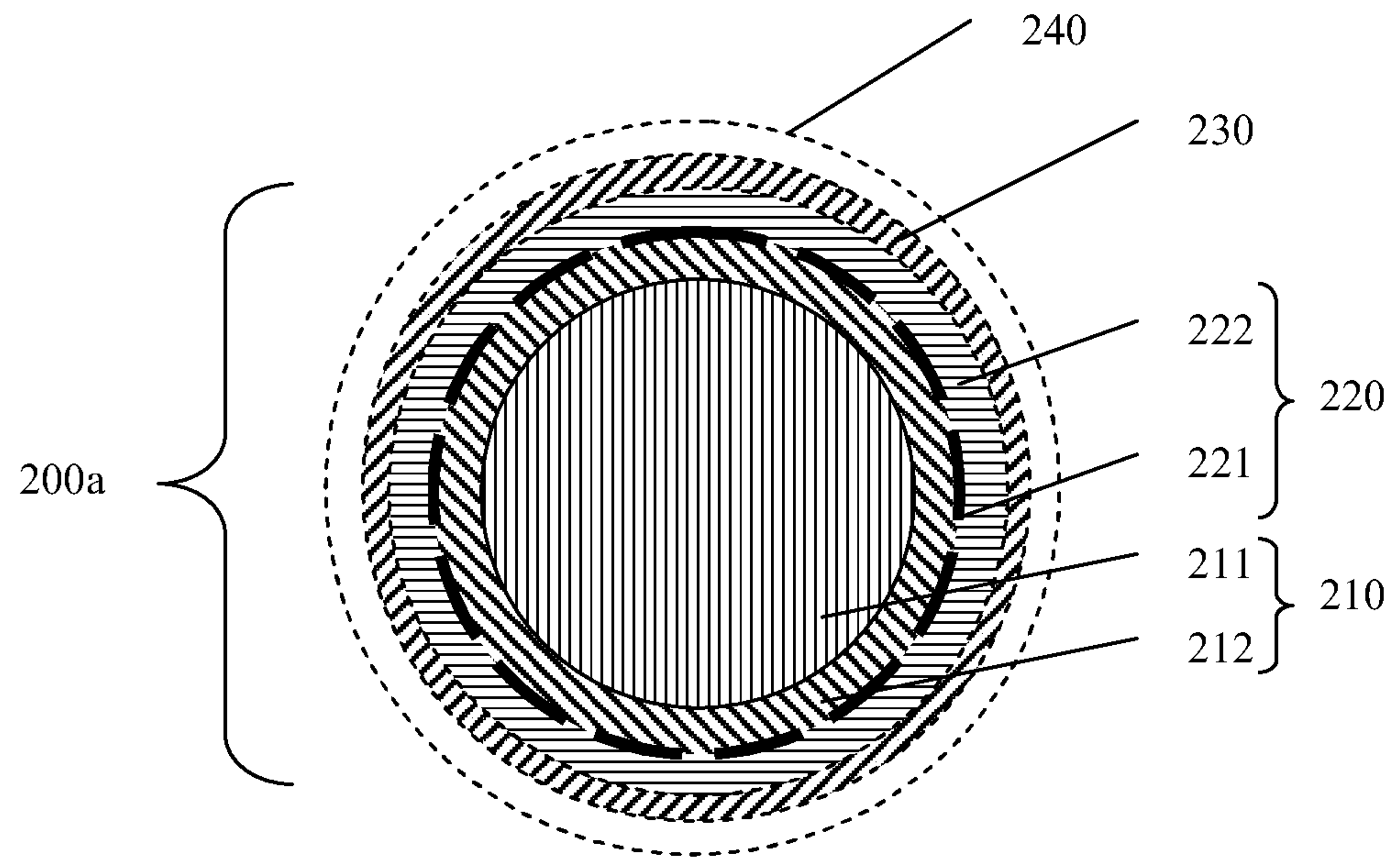

FIG. 2B

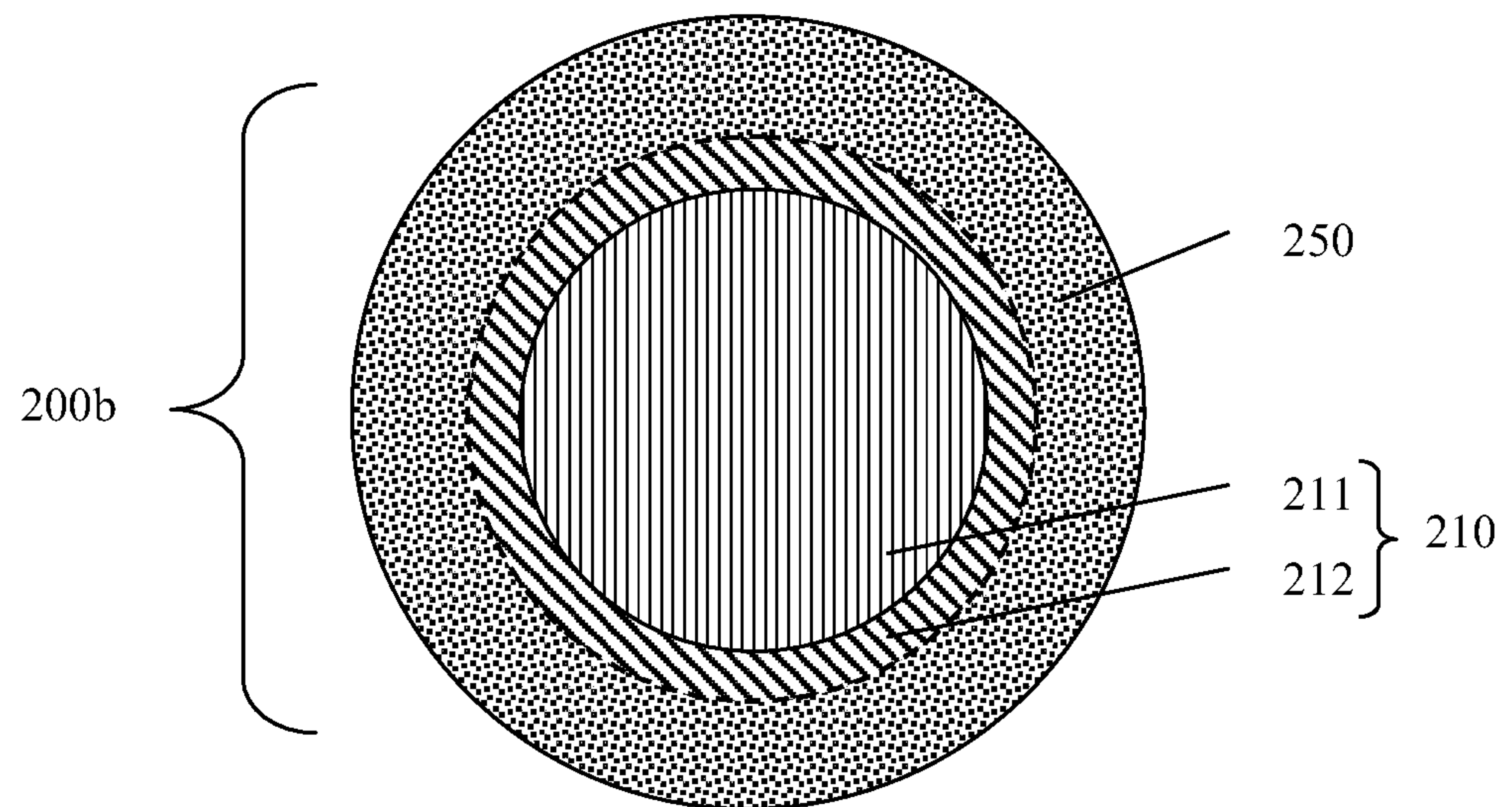

FIG. 3

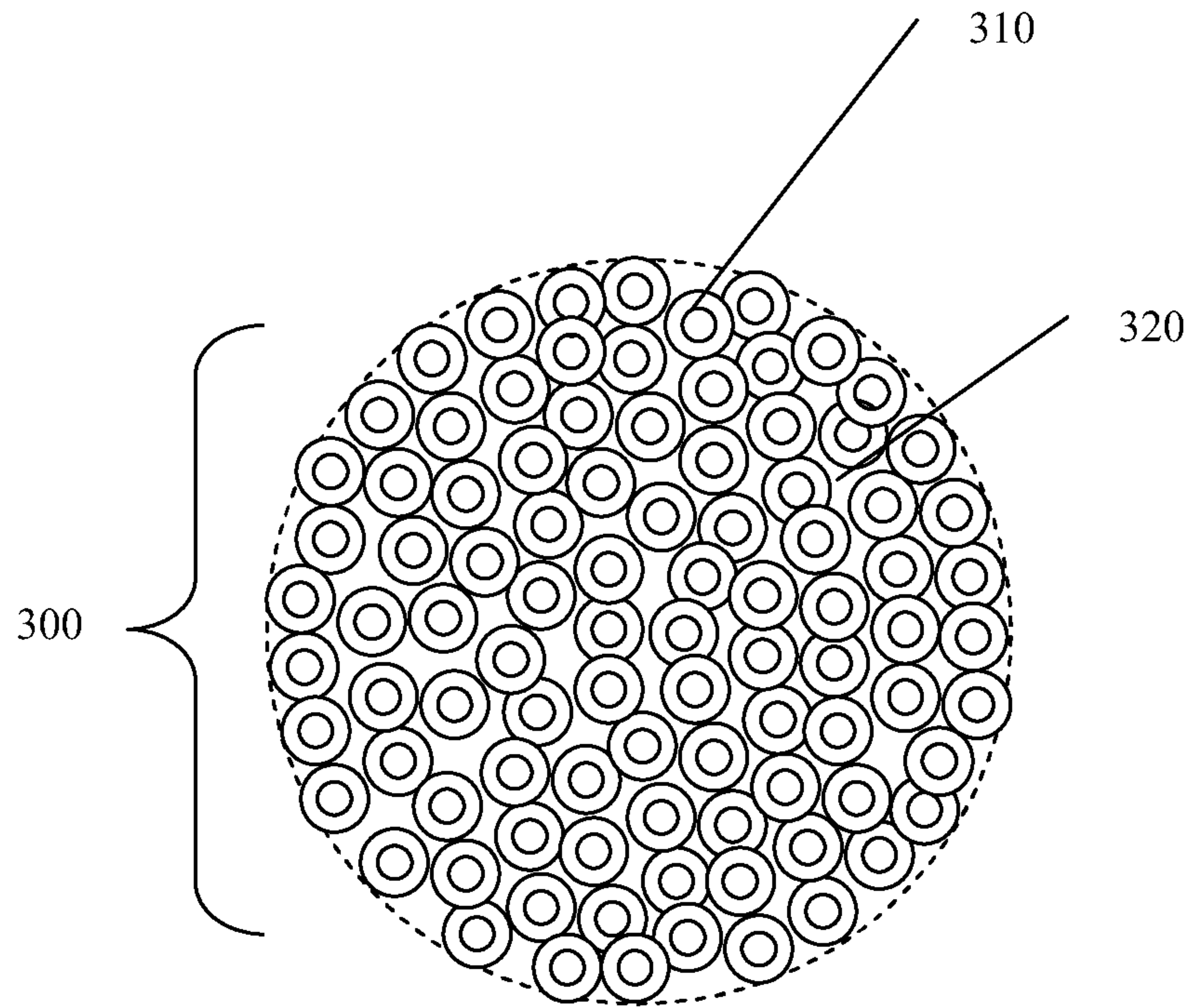

FIG. 1A

