

J. KAY.  
 APPARATUS FOR FEEDING AND GUIDING CLOTH TO STENTERING AND OTHER MACHINES.  
 APPLICATION FILED JUNE 26, 1909.

1,002,156. Patented Aug. 29, 1911.  
2 SHEETS—SHEET 1.

*Fig. 1.*

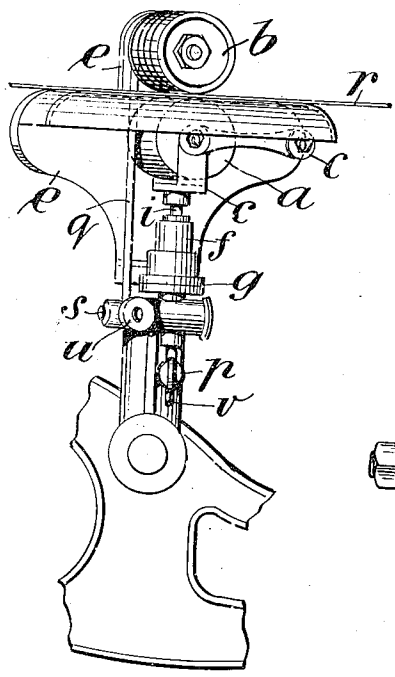

*Fig. 3.*

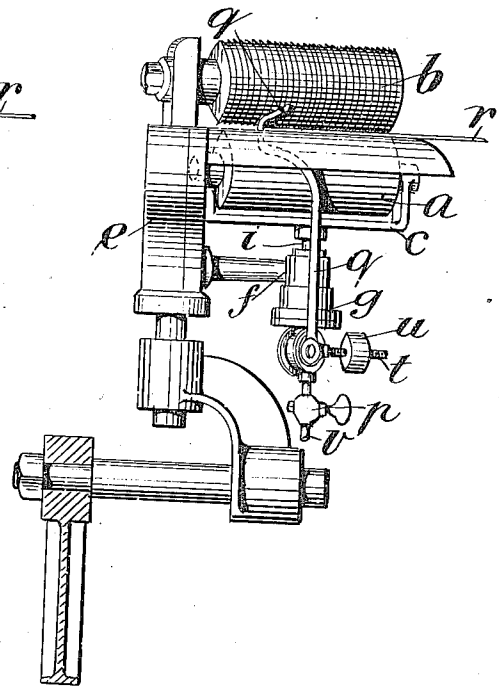

*Fig. 2.*

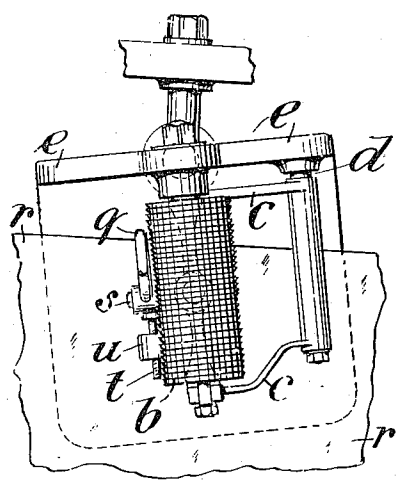

*Fig. 4. Fig. 5.*

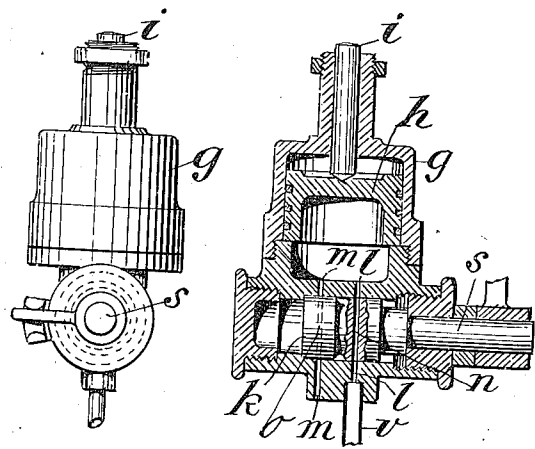

*Witnesses*  
*N. H. Hasler*  
*A. S. Ritchie*

*Inventor.*  
*John Kay*  
*Per Messrs. Cowich & Lawrence*  
*Attorneys*

J. KAY.  
 APPARATUS FOR FEEDING AND GUIDING CLOTH TO STENTERING AND OTHER MACHINES.  
 APPLICATION FILED JUNE 26, 1909.

1,002,156.

Patented Aug. 29, 1911.

2 SHEETS—SHEET 2.

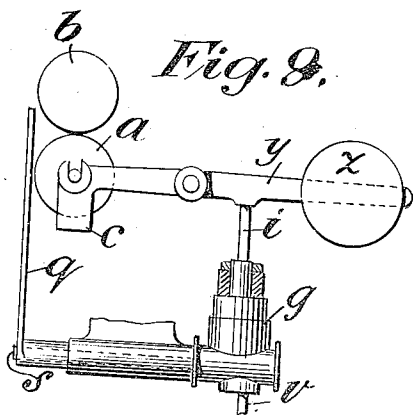
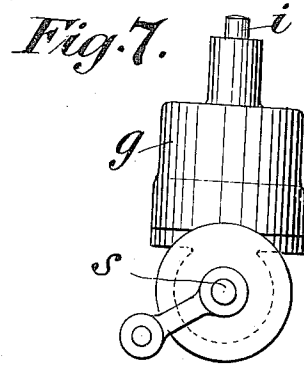
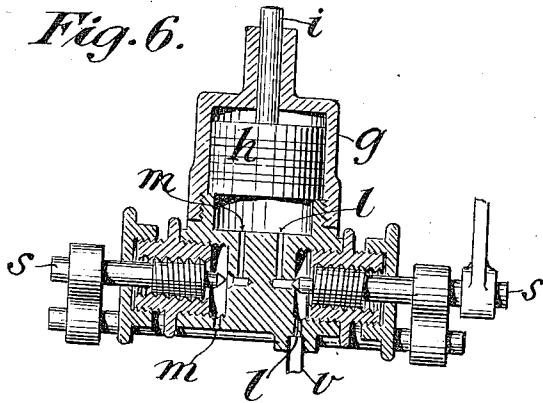

*Witnesses*  
*W. D. Hughes*  
*A. J. Kitchen*

*Inventor*  
*John Kay*  
*Per Attestation*  
*Attorneys*

# UNITED STATES PATENT OFFICE.

JOHN KAY, OF RAMSBOTTOM, ENGLAND, ASSIGNOR OF ONE-HALF TO WILLIAM HENRY FOXWELL, OF MANCHESTER, ENGLAND.

## APPARATUS FOR FEEDING AND GUIDING CLOTH TO STENTERING AND OTHER MACHINES.

1,002,156.

Specification of Letters Patent. Patented Aug. 29, 1911.

Application filed June 26, 1909. Serial No: 504,609.

To all whom it may concern:

Be it known that I, JOHN KAY, a subject of Great Britain, residing at Ramsbottom, in the county of Lancaster, Kingdom of Great Britain, have invented new and useful Improvements in Apparatus for Feeding and Guiding Cloth to Stentering and other Machines, of which the following is a specification.

My invention relates to improvements in that type of apparatus for feeding and guiding cloth to stentering and other machines which embodies the features set forth in the application for patent filed by me on the 16th day of July, 1910, Serial No. 572,261 and in which at each side one or more pairs of rollers are employed which when the cloth becomes stretched or tensioned abnormally are automatically rendered inoperative, that is to say, caused to separate and release the cloth. To render the said rollers alternately operative and inoperative apart from my said application, feelers in connection with electrical means have hitherto been employed which however in practice have been found unreliable.

The object of my invention is to obviate the said defects and consists in the use of air or steam pressure for rendering the said rollers operative or inoperative and in means for admitting such pressure and destroying it when the said rollers require to be inoperative or operative respectively. I attain this object by the mechanism illustrated in the accompanying two sheets of drawings, in which—

Figure 1 is an end view, Fig. 2 a plan, and Fig. 3 a side view of a pair of rollers and means for rendering the same alternately operative and inoperative constructed and arranged in accordance with one embodiment of my invention. Figs. 4 and 5 are respectively an elevation and a vertical section on an enlarged scale of the means shown in Figs. 1, 2 and 3, for operating the bottom roller of the said pair of rollers. Figs. 6 and 7 are respectively a vertical section and an elevation also on an enlarged scale, and Fig. 8 is a detached view of a modification in the construction and disposition of the said means.

Similar letters refer to similar parts throughout the several views.

In carrying out my invention and refer-

ring to Figs. 1, 2, 3, 4 and 5, according to one embodiment, I mount the bottom roller *a* of each pair of the rollers *a, b* in a suitable frame *c*, say by a stud *d* fulcrumed to the frame or bracket *e* of the apparatus in which is mounted the top roller *b* vertically stationary. Below the bottom roller frame *c* I employ upon an arm *f* extending from the base of the frame or bracket *e* a cylinder *g* containing a plunger *h*, see more particularly Figs. 4 and 5, the outer or upper end of which carries a pin *i* (or has a rod) bearing against and supporting the bottom of the roller frame *c* and its inner or lower end having a chamber. The cylinder *g* has also a piston or other suitable type of valve, in the present instance, a rotary valve *h* provided with a suitable inlet and outlet port *l, m* respectively, adapted to register alternately with the inlet *n* and outlet *o* and thereby connect the said cylinder and plunger chamber with a suitable compressed air, steam source or cut same off. The inlet *n* is controllable by a tap *p*, see Fig. 1, and connected with the said source. At one side of the frame *c* is suitably employed a vertical feeler or lever *q* the upper end of which is slightly curved for the edge of the cloth *r* to act upon laterally while its lower end is secured to the valve spindle *s*. The feeler or lever *q* has an arm *t* furnished with an adjustable balance weight *u*. In lieu of employing in connection with the said plunger a rotary valve such as described, a double screw down valve such as shown in Figs. 6 and 7, may be employed, having two valve spindles *s* located in a valve casing *g*, one of which has a left hand screw-thread and the other a right hand screw-thread and which are coupled together by a rod and two arms. The inner end of each of the said screw-threaded valve spindles is adapted to control the lower orifices of the ports *m* and *l* leading from the piston or plunger cylinder to the valve spindle chambers provided with the outlet ports *m* and *l* respectively while one of the said valve spindles has secured the feeler or lever *q* so that when the latter is moved one of the ports *m, l* will be closed and the other opened by the said valve spindles.

The operation of the apparatus is as follows:—Normally, the plunger *h* is raised by the compressed air, or steam supplied by

the pipe *v* entering the cylinder *g* and the said plunger chamber and the bottom roller *a* by means of its frame *c* held in contact with the top roller *b*. As soon as the cloth *r* is tensioned or stretched abnormally, the edge of the cloth contacts with the respective end of the feeler or lever *g* and pushing it sidewise, causes its lower end to turn and reverse the valve *k* and allow the compressed air or steam to escape from the cylinder *g* and the said plunger chamber instantly, when the plunger *h* and frame *c* carrying the bottom roller *a* are allowed to drop and bring the latter out of contact with the top roller *b*. As soon as the cloth has regained its normal width or tension, that is to say, the edges of the cloth have left the side of the feeler or lever *g*, the latter due to the weight *u* regains its normal position which causes the valve *k* to reverse, admit again compressed air or steam to the cylinder *g* and the said plunger chamber and by means of the said plunger the bottom roller to be raised again into contact with the top roller *b*.

According to a modification of my invention, see Fig. 8, the frame *c* carrying the roller *a* may have an arm *y* extending rearwardly from its fulcrum and furnished with a balance weight *z* which latter retains the bottom roller *a* in frictional contact with the top roller *b*, the cylinder *g* being so positioned as to cause the plunger rod *i* to act upon the weighted arm *y* of the roller frame *c*.

In lieu of fulcruming the bottom roller

frame *c* to the frame *e* of the apparatus it may be arranged to slide therein; again in the drawing annexed the rollers and means for rendering the same operative and inoperative are shown in connection with cloth running in a horizontal direction, but it will be readily understood without illustration, that the same may also be used for cloth running in an inclined or vertical direction.

I claim:

In an apparatus for feeding and guiding cloth to stentering and other machines, the combination with pairs of rollers through which the cloth passes and one of which is mounted in a hinged frame, of fluid pressure means for automatically rendering the said rollers operative and inoperative, comprising a cylinder and a plunger therein operated by the fluid pressure and adapted to control the movement of the said frame, a valve in connection with the said cylinder and a fluid pressure source and a feeler in operative connection with the edge of the cloth and the said valve, which feeler when acted upon by the said cloth causes the said valve to cut off and when released to admit fluid pressure to the said cylinder, all combined substantially as and for the purpose set forth.

In testimony whereof I have signed my name to this specification in the presence of two subscribing witnesses.

JOHN KAY.

Witnesses:

ALFRED BOSSHARDT,  
STANLEY E. BRAMALL.