

(19)



(11)

EP 3 608 466 B1

(12)

EUROPEAN PATENT SPECIFICATION

(45) Date of publication and mention of the grant of the patent:

15.05.2024 Bulletin 2024/20

(21) Application number: **18188263.0**

(22) Date of filing: **09.08.2018**

(51) International Patent Classification (IPC):

D06F 37/06 ^(2006.01) *D06F 39/04* ^(2006.01)
D06F 105/00 ^(2020.01) *D06F 105/52* ^(2020.01)
D06F 103/04 ^(2020.01) *D06F 103/46* ^(2020.01)
D06F 105/46 ^(2020.01) *D06F 105/10* ^(2020.01)

(52) Cooperative Patent Classification (CPC):

D06F 37/06; D06F 34/18; D06F 39/04;
D06F 2103/04; D06F 2103/46; D06F 2105/00;
D06F 2105/10; D06F 2105/46; D06F 2105/52

(54) LAUNDRY TREATING DEVICE AND METHOD FOR ITS OPERATION

WÄSCHEBEHANDLUNGSVORRICHTUNG UND VERFAHREN ZU DEREN BETRIEB

DISPOSITIF DE TRAITEMENT DE LINGE ET SON PROCÉDÉ DE FONCTIONNEMENT

(84) Designated Contracting States:

**AL AT BE BG CH CY CZ DE DK EE ES FI FR GB
GR HR HU IE IS IT LI LT LU LV MC MK MT NL NO
PL PT RO RS SE SI SK SM TR**

(43) Date of publication of application:

12.02.2020 Bulletin 2020/07

(73) Proprietor: **E.G.O. Elektro-Gerätebau GmbH**

75038 Oberderdingen (DE)

(72) Inventors:

- **Schaumann, Uwe**
75038 Oberderdingen (DE)
- **Schmidt, Kay**
75038 Oberderdingen (DE)

• **Torres Sanchez, Toni**

08520 Barcelona (ES)

• **Trave Ramis, Anna**

08520 Barcelona (ES)

(74) Representative: **Patentanwälte**

Ruff, Wilhelm, Beier, Dauster & Partner mbB
Kronenstraße 30
70174 Stuttgart (DE)

(56) References cited:

EP-A1- 2 524 989 EP-A1- 3 312 332
EP-A2- 1 467 012 JP-A- 2007 159 892
US-A- 3 938 260

EP 3 608 466 B1

Note: Within nine months of the publication of the mention of the grant of the European patent in the European Patent Bulletin, any person may give notice to the European Patent Office of opposition to that patent, in accordance with the Implementing Regulations. Notice of opposition shall not be deemed to have been filed until the opposition fee has been paid. (Art. 99(1) European Patent Convention).

Description

TECHNICAL FIELD AND PRIOR ART

[0001] The invention is directed to a laundry treating device, which in particular may be a washing machine or a laundry dryer. Furthermore, the invention is directed to a method for operating such a laundry treating device.

[0002] In the field of laundry treating devices such as washing machines or laundry dryers, there is a constant strive to improve laundry treating processes even further. One exemplary point of concern is to adapt the treating process to the kind of laundry being treated, which in particular means to various fibers, such as polyester, cotton or wool. This serves to better adapt the laundry treating process to the main portion of fibers present in the device for reducing the wear on the laundry. Furthermore, in the case of synthetic fibers such as mainly polyester, a problem arises by microfibers being flushed out of the device and into the sewage, where it is difficult to extract from the sewage. This is a rising environmental problem.

[0003] A washing machine is known from JP 2007159892 A, which includes a rotatable drum, a drive motor for rotating the drum and shape variable protrusions inside the drum. These protrusions serve as lifters to move pieces of laundry upwards with the rotation of the drum. The shape of the protrusions may be changed by a shape memory spring. The shape memory spring is being activated by the temperature of the water used in the washing process.

[0004] From EP 3 312 332 A1, another washing machine is known with protrusions similar to the ones mentioned before, which also act as lifters for pieces of laundry. Each lifter has an adjustable element being movably mounted to the protrusion between a first position and a second position. In both positions, the profile of the adjustable element is different thereby providing the protrusion with a varying outer shape. This serves for varying treatment and movement of the laundry when the drum is rotating.

[0005] Another protrusion as a lifter with variable shape is known from the washing machine of US 3 938 260. In this embodiment, a kind of prolongation of the protrusions can be manually pulled out with a direction towards a central rotation axis of the drum of the washing machine. This serves for a much better lifting action on pieces of laundry being inside the rotating drum.

[0006] From EP 2 524 989 A1 it is known to provide a drum of a washing machine with protrusions or lifters on the inside. The drum is being rotated by a drum motor, and a torque signal from the motor while rotating the drum is being monitored. A falling of laundry from the lifter at a certain point of rotation can be determined based on a negative slope of the motor torque signal.

SUMMARY OF THE INVENTION

[0007] It is thus an object of the present invention to

provide a laundry treating device as well as a method for its operation with which problems of the art can be avoided and, in particular, a laundry treating process can better be adapted to specific types of laundry or fibers the laundry is made of, respectively.

[0008] This is solved by a laundry treating device according to claim 1 and a method for its operation according to claim 8. Advantageous and preferred configurations of the invention are the subject of the further claims and are explained in more detail below. In this case, some of the features are described only for the laundry treating device or only for the corresponding method. However, regardless of this, they are intended to be able to apply by themselves for the laundry treating device and for the corresponding method independently of one another. The wording of the claims is made the content of the description by means of express reference.

[0009] The laundry treating device may preferably be a washing machine, a laundry dryer or a combined device with both functions. The laundry treating device has a rotatable drum having a circumferential drum wall, wherein the laundry is being placed in the drum for the laundry treating process. A drive motor for the drum is provided as well as a power control unit, which serves to supply a drive current to the drive motor. The drive motor as well as a force transmission to the drum can be as known in the art, preferably with a belt. Furthermore, current sensor means are provided for supervising the drive current being supplied to the drive motor. These current sensor means are preferably extremely sensitive and very accurate. A rotation position sensor means is provided for supervising a rotation position of the drum. They preferably can discriminate the rotation position of the drum down to rotation angles of about 5°, preferably about 3° or only 1°. At least one protrusion is provided on an inside of the circumferential drum wall, preferably two or three such protrusions. These protrusions are basically known and provided as a standard in such laundry treating devices. They serve to better agitate and rotate the pieces of laundry during a washing process as well as during a drying process of wet laundry. Such protrusions are known in a wide variety of shapes.

[0010] According to the invention, the at least one protrusion is variable, movable and/or flexible in its height over the inside of the circumferential drum wall. In addition or as an alternative, the protrusion may be variable in its outer shape or, respectively, its cross-section when viewed in axial direction of the drum. Actuation means are also provided to effect a change of this height or this shape of the protrusion. These actuation means are preferably such that they can be controlled and activated in exact manner as wanted.

[0011] In this way the invention provides a possibility to have the variable protrusions adapt to different kinds or stages of laundry treating processes. This may differ between rinsing the laundry at the beginning of the washing process, the washing itself as well as a spinning of the laundry close to the end to remove water out of the

laundry. Furthermore, by changing the shape of the protrusion in an exactly defined way during a specific program of the device, it is possible to retrieve information about the laundry being present in the drum, in particular to detect the majority of the kind of fibers of the laundry in the drum. This is being done with the method of the invention, wherein in a first and preceding step of the method, various reference curves for the drive current of the drive motor are recorded, wherein the shape of the protrusion is varied.

[0012] For each mentioned reference curve, the shape of the protrusion is being varied.

[0013] These reference curves are stored in a storage of the laundry treating device, which is in its device control and a storage thereof. In a further second step, when the device is loaded with laundry in its drum, a testing is performed as second step before the actual treatment or treating of the laundry begins. The shape of the protrusion is varied. The drive current is monitored or supervised during this second step, in particular as a continuous curve, and then a comparison is made with the various reference curves of the above-mentioned storage. This serves to determine at least one variable of the group of weight of the laundry, typical size of pieces of laundry, and, above all, major fiber portion of the laundry by the best corresponding or most similar curves. After this, the actual treatment of the laundry in the device is adapted to the variable or variables detected before, which means to the weight of the laundry, typical size of pieces of laundry and/or major fiber portion of laundry. Such a discrimination of these characteristics of the laundry is mainly achieved by a very accurate supervision of the drive current supplied to the drive motor. This is based on the aspect of the invention that, especially with a rather low speed of the drum with less than 100 rpm, preferably between 50 rpm and 30 rpm, the typical behavior of laundry inside the drum is between being rotated together with the drum with mostly no relative movement to the drum or falling off the inner walls of the drum or off the protrusions at a certain height. A signal in the current sensor means for the drive current indicates when laundry is falling off of the protrusion or is sliding over the protrusion during the rotation movement, because in this case the load on the drive motor is slightly reduced. When the pieces of laundry fall down onto the lower part of the inside of the drum wall, the drive motor is slightly slowed down and, in consequence, has to produce a slightly larger moment. This can then be detected in the drive current, preferably as small spikes, which information in turn can be combined with the position information of the drum together with the information about the rotation speed of the drum.

[0014] It becomes clear from the aforesaid that the main purpose of the invention is to improve the actual treatment of the laundry by making use of the information about weight of the laundry, typical size of pieces of laundry, major fiber portion or the like, that has been gathered before. The role of the variable or flexible protrusions is

essential to gather this information by allowing variations of the way the laundry is rotated in the drum.

[0015] By changing the drum rotation direction it is possible to make use of different variations of the shape of the protrusions if they are not symmetrical as described above. This allows for the protrusions not to have to be shape-variable along both directions along a circumferential direction of the drum. They only need to be flexed to one side with one drum rotation direction. A flexing to the other side can be dispensed of by simply changing the drum rotation direction into the opposite.

[0016] In the invention, the laundry treating device has a device control having a processing means for calculating or processing a rotation position of the drum and for processing a drive current from the respective sensor means for the drive current. Such a processing means preferably is a microprocessor or a respective controller. The rotation position of the drum is preferably calculated by detecting a rotation position of the drive motor for the drum, for example by an incremental encoder provided on the drive motor as is known in the art. The processing means is also adapted to calculate the load or weight of laundry in the drum, in particular by making use of the information from the drive current sensor means. The processing means also calculates the major fiber portion of the laundry by the information gathered by the comparison of actual parameters with various reference curves as explained before. In consequence, the processing means may adapt at least one parameter of a further laundry treating process to better take into account the detected load and/or a major fiber portion of the laundry. This may serve to better clean the laundry, treat it faster or in a more energy-saving way, to treat the laundry with more care and also to avoid unnecessary or avoidable formation of microfibrils made from synthetic material. This can be achieved by changing, preferably lowering, a temperature of the water used for the laundry process, a shape of the at least one protrusion or preferably a rotation speed of the drum. It is also possible to introduce certain additives or additional laundry treating substances into the laundry treating process when it has been detected that the laundry is mainly or only made up of pieces of synthetic material. Those additives may for example reduce the friction of the laundry or its fabric, respectively, resulting in a reduction of microfibrils produced.

[0017] The storage mentioned before for the processing means is adapted to store various groups of curves or diagrams, which are being representative of a dependency of the drive current of the load in the drum as well as of the major fiber portion of the laundry. One additional variable to these two values is a certain position or shape of the at least one protrusion. This is a preferable way to create a basis for making a better comparison mentioned before.

[0018] Supervising or measuring the drive current supplied to the drive motor may also serve to measure a force or an impulse, respectively, acting on the drum

when pieces of laundry slide down in the drum along the inside of the circumferential drum wall during rotation of the drum. Such a sliding of the laundry usually ends when they hit the next protrusion rotating together with the drum. The higher the force or impulse, the more representative a signal or variation of the signal in the drive current is.

[0019] In a further embodiment of the invention, a water level sensor or a water amount sensor in the drum is provided. This additional information may also be used in the processing means to better evaluate information about the laundry. During the afore-mentioned second step of testing the laundry being present in the drum, the laundry should be wet with water, but preferably there is no water in the drum or in its lower region, such that the drum does not rotate in such residual water in its lower region.

[0020] Also a temperature sensor for the water temperature may be provided, for example in a lower region or a sump of or for the drum. Such a temperature sensor not only serves for taking the water temperature into account during the second step of testing the laundry, but also for heating the water of the washing process to a certain temperature in an exact way.

[0021] For changing the height or the shape or, respectively, the overall form of the protrusion, a passive actuating device may be provided in one embodiment of the invention. This means that there is no directly energized mechanic actor such as an electric motor or an electromagnetic device provided in the drum or in the protrusion itself, respectively. Such a passive actuation device preferably comprises temperature dependent shape changing material, which may be in the form of a spring, a lever or a rod. This passive actuation device can be influenced by varying its temperature. This may be either made by changing the water temperature inside the drum, so that the actuation means is being influenced by this water temperature, which in turn again can be influenced by respectively heating the water. Such is easy in a laundry treating device such as a washing machine. Alternatively, the passive actuation device can be directly heated, preferably inductively.

[0022] In a preferred embodiment of the invention, especially as a passive actuation device, the actuation device is shape variable in a temperature range that is common for treating laundry. It may be provided that the actuation device and, in consequence, also the protrusion may have a first shape at a temperature of below 30 °C. They may have a second shape at a temperature above 30 °C. It may even be provided that there is at least one further temperature step with the actuation device having a third shape at a temperature above 40 °C. Such a division into steps of about 10 °C allows for exact influencing of the actuation device, while at the same time using a temperature range that is still acceptable for most pieces of laundry to be treated.

[0023] In another embodiment of the invention, the temperature dependent shape changing material of the

actuation means for the protrusion can be inductively heated. This is achieved in an easy way by the shape changing material being made of ferromagnetic material or any other material that may be inductively heated or being in contact with such inductively heated material. This allows for an induction heating device to heat the actuation means to be placed outside of the drum. Then the induction heating device is placed at a dry place where it can also be easily fixed or repaired, because it may be fixed to a drum receptacle of the laundry treating device which is not movable or does not rotate, respectively. This facilitates also an electrical connection to this induction heating device due to a simple way of fixing. The actuation device may pass by radially inward of the induction heating device and be heated consequently when in range, even though this may be for a short span of time when the drum is rotating at constant speed. To allow for a faster or more intense heating, a long induction heating device may be provided or, alternatively, several induction heating devices placed one next to the other. It may also be provided that the drum is brought into a position where the actuation means are directly close to the induction heating device, stopping the drum or resting the drum in this position for some time, for example 3 sec to 10 sec, for the induction heating device to sufficiently heat the actuation device for effecting its change of shape, which in turn effects a change of shape of the protrusion. After that, as it may take some time for the actuation means to cool down and change shape back again, the second step of the invention with testing the behavior of the laundry in the drum may be continued.

[0024] In a preferred embodiment of the invention, the protrusion is made from elastic and flexible material in the form of a trough. Such a trough has two longitudinal end edges, which are advantageously parallel to each other. The protrusion is fixed to the inside of the drum with these two end edges. This results in that in an initial state of the protrusion, it has a certain initial height as well as a certain initial profile. This may be symmetrical as explained before, but need not be. In at least a further state of the protrusion, the height is being slightly diminished, wherein the protrusion is flexed laterally to the side along a circumferential direction of the drum. This may be done in a small number of steps, for example up to three steps. On the one hand, the discrimination between varying behavior of the pieces of laundry in the drum allows for more detailed analysis. On the other hand, the step of testing too many varying parameters may take too long for the user to wait before the actual laundry treating process may begin. Furthermore, it should be ascertained that the state of the protrusion and also the state of the actuation device is known, which again means that not too many varying states of the protrusion should be used, lest an error is made.

[0025] Although an initial state of the protrusion may be symmetrical in its profile when viewed from the side, this is not mandatory. A height of the protrusion may be between 3 cm and 10 cm. A flexing laterally to the side

of the protrusion may be in a range between 1 cm and 3 cm, which means between 10% and 50% of its height. The protrusion may also be water permeable, for example by having small holes or being perforated.

[0026] It is also possible to vary the shape of the protrusion in the first or in the second step such that it includes flexing the protrusion from a maximum into one direction along the circumferential direction of the drum to a maximum into the opposite direction. Preferably, the flexing between these two maxima takes place in steps. It is most preferable if there are at least three steps.

[0027] The protrusion may be made from sufficiently flexible material such as thin metal sheet, preferably made from stainless steel. Preferably, the protrusion is made from synthetic material. The actuation means are preferably located inside the protrusion such that they are not damaged by the laundry or a high number of laundry treating processes. The actuation means may be arranged sealed against water inside the protrusion. Preferably, however, they may well come into contact with the water inside the drum and, consequently, be sufficiently protected against corrosion by the use of suitable material. This allows for the actuation means to be heated or cooled directly by the water in the drum.

[0028] These and further features are evident not only from the claims but also from the description and the drawings, the individual features each being implemented by themselves or in multiples in the form of subcombinations for an embodiment of the invention and in different fields and being able to be advantageous and independent protectable embodiments for which protection is claimed here. The division of the application into individual sections and subheadings does not limit the general validity of the statements made thereunder.

Brief Description of the Drawings

[0029] In the following, an embodiment of the invention will be described in detail with reference to the drawings. Throughout the drawings, the same elements will be denoted by the same reference numerals.

- Fig. 1 a schematic front view onto a washing machine according to the invention with pieces of laundry in it,
- Fig. 2 a schematic drawing of the forces acting on a piece of laundry in the drum of the washing machine,
- Fig. 3A to 3D various courses of actual movement of pieces of laundry in the drum with a variation of fiber and size,
- Fig. 4 a simplified curve of the drive current over time with spikes indicating movement of pieces of laundry,
- Fig. 5 an enlarged drawing of a protrusion in the drum having inner actuation means and an outside induction coil for activating them,

Fig. 6

the actuator of Fig. 5 in detail being made up of a socket with a rod in it, a conventional spring and a spring made of temperature dependent shape changing material, at a temperature below 30 °C and at a temperature above 30 °C,

5

Fig. 7

a schematic drawing of the protrusion on the inside of the drum according to Fig. 5 with three different shapes and another schematic drawing of the protrusion according to Fig. 5 with a symmetric change of shape to both lateral sides.

10

Fig. 8

15

Detailed description of the embodiments

[0030] From Fig. 1 a schematic drawing of a washing machine 11 according to the invention can be taken. Washing machine 11 has a housing 12 with a rotating drum 14 in it being placed in a fix drum receptacle 13 surrounding it. Drum 14 is rotated or driven, respectively, by a drive motor 16 with drive belt 17 as is common in the art. On the inside of drum 14, three protrusions 19 are provided in rib-like form or in the form of a triangle with a rounded tip pointing inside the drum 14. The protrusions 19 are shown in profile and can preferably have this form in a direction parallel to the rotation axis of drum 14.

20

25

30

[0031] Inside drum 14, several pieces of laundry 30 are shown being rotated and thrown about. This will be described in detail later.

35

[0032] Drive motor 16 is driven or energized by power control unit 32, which again is controlled by control 34, preferably being the main control of the whole washing machine 11. Control 34 is connected to a current sensor 35 which is able to exactly supervise the drive current supplied to drive motor 16 by the power control unit 32. Such a current sensor is known in the art and can be provided by the person skilled in the art without any problem. It may also be integrated into the power control unit 32 or into the drive motor 16 itself.

40

45

[0033] Integrated into drive motor 16 is a rotation position sensor means for supervising or detecting a rotation position of the drum, which is not shown here due to the integration. Such a rotation position sensor means can be integrated into the drive motor 16 as is also common in the art, preferably as an incremental encoder. The rotation position sensor means is also connected to the central control 34.

50

[0034] Control 34 is also provided with a storage 37 as explained before and will be explained in detail hereinafter, preferably being integrated into one semi-conductor component. Finally, on the outside of drum receptacle 13, an induction coil 40 is provided as an option. Induction coil 40 may serve to act upon an actuator inside protrusion 19, which will also be described in detail hereinafter. Induction coil 40 may also be very long along the circum-

55

ferential direction of the drum receptacle 13, for example taking up a quarter or even a third of its circumference. Alternatively, a number of single and rather small induction coils may be provided along the circumference.

[0035] In Fig. 2, for better basic understanding, drum 14 is shown with a piece of laundry 30 in it. A center of gravity or mass of the piece of laundry 30 is at an angle α to the vertical axis as indicated by the dashed line. Laundry 30 is abutted against the inside of drum 14 due to rotation of the drum 14. The force of gravity F_{GR} is pointing vertically downwards. The centrifugal force F_{CE} generated by the rotation of the drum and depending on its rotation speed is pointing outwards in radial direction away from a center of drum 14 and through the center of gravity of the laundry 30. A frictional force F_{FR} is pointing upwards from the region of contact of laundry 30 with the inside of drum 14 in a circumferential direction or in tangential direction, respectively, which is also at right angle to the centrifugal force F_{CE} . A sliding force F_{SL} is pointing in the opposite direction of the frictional force F_{FR} . The laundry 30 is moved counterclockwise with rotating drum 14 by the frictional force F_{FR} , if it does not abut against a protrusion 19. The sliding force F_{SL} is way of pulling laundry 30 downward again initiated by the gravity force F_{GR} . When the fabric or the fibers of laundry 30 have a small friction coefficient and/or laundry 30 is lightweight, possibly because it does not take up much water, then there is not enough frictional force F_{FR} . In consequence laundry 30 is simply sliding down on the inside of drum 14, most probably also over a protrusion 19. So the behavior of the laundry 30 of being easily rotated with drum 14, especially with the aid of the protrusions 19, depends among others on the friction coefficient of laundry 30 which is also dependent on the type of fiber it is made of.

[0036] It is also easy to conceive that the behavior of the laundry 30 also largely depends on the height and the shape of protrusion 19, whether the laundry 30 can slide over it instead of rotating with protrusion 19 or not. So it is easy to conceive that by changing the shape of protrusion 19 different kinds of behavior of laundry 30 can be generated and detected. As the speed and also the angle of rotation of drum 14 is known by way of the rotation position sensor explained before, and due to the fact that this is correlated with the position of the protrusions 19, a signal or a group of signals can be obtained which give an indication of the behavior of laundry 30, which in the end can help to distinguish which kind of fabric laundry 30 is made of, especially which is the major fiber portion, as well as potentially the size of laundry 30. This may help to define optimum process parameters for a laundry treatment process, especially washing the laundry, for the process to be gentle to the fabric to reduce wear of the fabric as well as the generation of fibers or microfibers, respectively. On the other hand, it should of course be ensured that the laundry is cleaned during the washing process.

[0037] A detection whether the piece of laundry 30 is

sliding over the protrusion 19 or whether it is taken along with protrusion 19 into the rotation movement can be made by supervising the drive current of drive motor 16. In the first case, when laundry 30 slides over the protrusion, a slight, but noticeable ease on the drive motor and the drive current in consequence takes place for a very short span of time until the laundry 30 falls into lower part of drum 14, where it has to be put into rotational movement again, which means that additional strain has to be brought up by the drive motor 16. This results in some kind of spike in the drive current, however small this may be. This additional strain in the form of a spike or any other discontinuous change in the drive current can be detected by corresponding exact current sensor means.

[0038] In the second case, when the laundry 30 does not slide over protrusion 19, but is rotating with it and with drum 14, the drive current may slightly vary depending on whether the laundry 30 has to be lifted up in the right upper quadrant of drum 14 according to Fig. 2, possibly also in the right lower quadrant. In the other two quadrants to the left side, the drive current is slightly lower. In any case, if the laundry does not slide over protrusion 19 or does not fall down, there are no discontinuous spikes in the drive current. This will be explained later on in Fig. 4.

[0039] Figs. 3A to 3D show the simplified result of experiments with laundry of two different types of fibers and different sizes. The laundry has been marked with a kind of characteristic point, and the movement of this characteristic point has then been recorded with a video camera. The result is shown in simplified tracks or courses that the laundry has taken. All the four figures have been recorded in the experiments with a rotation speed of 46 rpm.

[0040] In Fig. 3A, a rather small piece of laundry with a size of about 40 cm x 40 cm made from polyester has been used. It is obvious that this laundry has a low coefficient of friction and is rather lightweight. It is always sliding and does never even make a half or quarter rotational movement.

[0041] Fig. 3B shows a rather small piece of laundry made from cotton, but with the same size. It can be seen that, on the one hand, the piece of laundry has several times been fully or almost fully rotating with drum 14, but that some times it also has been sliding over the protrusion in a way similar to Fig. 3A.

[0042] In Fig. 3C, a piece of laundry made from polyester has been used, but being four times larger than before with a size of 80 cm x 80 cm. It can be seen that the piece of laundry has been lifted somewhat higher by the protrusion during rotation of drum 14, but still is always sliding over the protrusion.

[0043] A comparable piece of laundry made from cotton again with the same size of 80 cm x 80 cm is shown in Fig. 3D, which is then mostly making the full rotation with drum 14. It is only rarely sliding over the protrusion or falling down from its top position.

[0044] When taking Figs. 3A to 3D in mind and looking at Fig. 4, which shows drive current i_D over time t , it is easily conceived that the behavior of the piece of laundry

which in practice is shown by Figs. 3A to 3D can be read out from supervising the drive current i_D . The presence of the spikes or steps in drive current i_D is a clear indication that sliding and particularly falling of laundry takes place which impacts the motor torque of drive motor 16 and can consequently be seen in the drive current i_D . In the storage 37 of control 34, various such curves for the drive current are stored, each one for a defined set of values for the variables mentioned before. By comparing the measured drive current i_D with other drive current curves stored in storage 37, as a kind of reference, the most similar one can be found. This stands for a set of such values. To verify this set of values, at least one further curve for the drive current i_D can be obtained, with some parameters changed, for example the shape of protrusion 19. This will result in another comparison and another verification of a most similar reference curve representing a set of such values. After a small number of such comparisons, it is usually possible to determine the values being most similar. Then the information about the details of the laundry being present inside drum 14, that has been gained by the comparison detailed before, is used for optimizing the further laundry treating process. This can be done as explained at the beginning.

[0045] It is now also easily conceivable that the information according to Figs. 3A to 3D can even more be diversified by varying the shape of the protrusions 19. This is now what the invention is not only but mainly about. It is also advisable to make the process of detection of the type of fiber and the size of the laundry when drum 14 is not full, but preferably at most filled with half its nominal load, more preferably with only a third of its nominal load. This allows for each single piece of laundry to mostly have sufficient space for allowing a relative free movement inside the rotating drum 14.

[0046] Fig. 5 shows in a side view an enlarged protrusion 19 fixed to the inside of drum 14. An actuator 22 is mounted on top of a metallic base 20, preferably made from or containing aluminium, and abuts with its right end against the inside of protrusion 19. Protrusion 19 is made from an elastic sheet material such as synthetic material or, alternatively, thin stainless steel. Actuator 22 can move to the right as is shown by the arrow into the position represented by the dotted line, thereby pushing protrusion 19 to the right side into a position of protrusion 19' in dashed line. It is easy to conceive that if the drum 14 is rotating anti-clockwise, modified protrusion 19' is allowing laundry 30 to slide over it more easily than protrusion 19. If drum 14 is rotating clockwise, however, protrusion 19' is having a stronger hold on a piece of laundry resulting in the laundry sliding not so easily over it. This variation of the shape of protrusion 19 allows for even more variation of collecting information on the type and size of laundry inside drum 14 during rotation. It is a further option to influence the sliding behavior of laundry over the protrusion, which allows for an even better discrimination of the type of laundry.

[0047] As has been explained before, actuator 22 com-

prises or consists at least partly of shape changing material, which change of shape depends on temperature. For influencing the temperature of actuator 22, or alternatively of base 20 which again may heat up actuator 22, an induction coil 40 is positioned on the outside of receptacle 13 which is controlled by control 34, as has been explained with regard to Fig. 1. Even for a very short span of time while drum 14 together with base 20 is rotating and moving relative to induction coil 40, this may allow for heating up at least to some degree. Another option as an alternative is to vary the temperature of water inside drum 14, which is at least variable between room temperature of about 20 °C and elevated temperature of about 40 °C. It is also possible to provide longer or more such induction coils 40.

[0048] One possible way of realizing such an actuator 22 can be taken from Fig. 6. A socket 24 has a socket spring 25 made of shape changing material with a temperature dependency, abutting against its base. A hollow rod 27 is inserted into the socket 24 containing a rod spring 28 made from conventional steel. Rod spring 28 abuts against the bottom of rod 27, against which socket spring 25 abuts from the other end. So the two springs 25 and 28 press one against the other. The right end of rod spring 28 abuts against a counterpart inside rod 27, which counterpart is affixed to the outer socket 24. The lower position of actuator 22 in Fig. 6 is present at a temperature of less than 30 °C. It can be seen that socket spring 25 has a length of about a third of the length of rod spring 28. When the temperature is rising above 30 °C, for example up to 35 °C or even up to 40 °C, socket spring 25 is extending due to having passed its point of shape change. It extends by exerting more force against rod spring 28 and, at the same time, compresses rod spring 28 to result in that both springs 25 and 28 have about the same length due to a balance of their spring forces. This is the upper position of actuator 22 in Fig. 6. Rod 27 is pushed out of socket 24 by some distance d , resulting in a lengthening of actuator 22 in its overall length. So it can easily be seen that by changing the temperature of actuator 22 or socket spring 25, it can be varied in its length which can be used according to Fig. 5. It is easy to conceive that also rod spring 28 could be made of shape changing material so that the lower longer state of actuator 22 can be at a higher temperature and the upper state at a higher temperature. The advantage of making socket spring 25 from shape changing material is that it can be heated by base 20 and socket 24 more efficiently. It is also possible to make socket 24 from material that can be heated inductively, which would provide for a more direct heating of socket spring 25. The heating of base 20 or socket 24 itself is easily conceived by a person skilled in the art, for example by induction coil 40. If a change of water temperature is used to change the shape of actuator 22, this need only be done for a short time, preferably 5 minutes at most. So even laundry that should be treated with low temperatures of no more than 30 °C can be processed in this way for an analysis.

[0049] In Fig. 7, protrusion 19 mounted to the inside of drum 14 is varied two times in its shape, for example with an actuator not shown but basically similar to the one of Fig. 5. The shape of protrusion 19' in dashed lines as the first variation has a height h_2 which is slightly less than the height h_1 of protrusion 19 in its original and symmetrical state. If protrusion 19' is deformed even more, perhaps by an additional actuator with even another temperature for a shape change, it will result in protrusion 19'' having a shape represented in chain dotted line. This protrusion 19'' has an even more reduced height h_3 and, more particular, its shape is asymmetrical to such a degree that, depending on the direction of rotation of drum 14, its effect on laundry regarding sliding down or not is foreseeably very strong. This protrusion 19'' will be able to move laundry along with it very easily and efficiently, with only very slippery pieces of laundry sliding over it instead of being taken along in the rotation of the drum 14.

[0050] Another option of changing the shape of protrusion 119 affixed to the inside of drum 114 is shown in Fig. 8. Mounted onto a base 120 are two actuators 122 similar to the one of Figs. 5 and 6, but pointing and working in opposite direction. In the normal position of actuators 22, which again contain shape changing material as explained before, they abut on the inside of protrusion 119 which has a shape as shown for example in Figs. 1 and 5. When the actuators 122 are activated, preferably again by a change of temperature, they are in the position according to the dotted line and push the opposite walls of protrusion 119 apart, resulting in a change of shape represented in dashed lines. This new shape of protrusion 119' in dashed lines is still symmetrical to the same line of symmetry as protrusion 119, but somewhat flattened and also widened at its free end. This modified protrusion 119' has an effect onto the laundry 30 independent of the rotation direction of drum 14, but will still be noticeable.

[0051] By varying the shape of the protrusions during a testing sequence with laundry put into washing machine 11, and evaluating the data resulting from supervising the drive current, control 34 can distinguish which is the major part of fiber of laundry 30 inside drum 14 as well as potentially its typical size. A washing process that is to follow can then be adapted to this information, preferably by mainly trying to reduce the wear onto the laundry if it has been detected that it is substantially or mostly made up of synthetic fiber such as polyester. This again reduces the generation of microfibers into the sewage water of the washing process, which is of growing importance for ecological reasons.

Claims

1. Laundry treating device (11), in particular a washing machine or a laundry dryer, having:

- a rotatable drum (14, 114) having a circumfer-

ential drum wall for placing the laundry (30) in,
- a drive motor (16) for the drum (14, 114),
- at least one protrusion (19, 119) on an inside of the circumferential drum wall,

wherein

- the protrusion (19, 119) is variable and/or movable or flexible in its height over the inside of the circumferential drum wall, and/or the protrusion is variable and/or movable or flexible in its outer shape,
- actuation means (22) are provided for effecting a change of height or shape of the protrusion (19, 119),
- a power control unit (32) for supplying a drive current to the drive motor (16),
- current sensor means (35) for supervising the drive current supplied to the drive motor (16),
- a device control (34) is provided having a processing means for calculating a rotation position of the drum (14, 114) and/or a drive current from the respective sensor means (35),

characterized by:

- rotation position sensor means for supervising a rotation position of the drum (14, 114),
- in the processing means a storage is provided in which various groups of diagrams are stored being representative of a dependency of the drive current of the load (30) in the drum (14, 114) as well as of the major fibre portion of the laundry (30), wherein the diagrams have a variation of the drive current depending on the shape of the protrusion (19, 119) being varied,
- the processing means is adapted to calculate the load or weight of laundry (30) in the drum (14, 114), the typical size of pieces of laundry (30) in the drum (14, 114) and/or the major fibre portion of the laundry (30).

2. Device according to claim 1, wherein the processing means is adapted to calculate the load or weight of laundry (30) in the drum (14, 114) and/or the major fibre portion of the laundry (30) for adapting parameters of a further laundry treating procedure to the detected load and/or major fibre portion, preferably with regard to temperature of the water, rotation speed of the drum (14, 114) or shape of the at least one protrusion (19, 119).

3. Device according to one of the preceding claims, wherein the actuation means (22) for changing the height or shape of the protrusion (19, 119) is a passive actuation device (22), in particular with a temperature dependent shape changing material in the form of a spring or a lather or a rod (20).

4. Device according to claim 3, wherein the actuation device (22) is shape variable such that a first shape is present at a temperature below 30 °C and that a second shape is present at a temperature above 30 °C, wherein preferably a third shape is present above 40 °C.
5. Device according to one of the preceding claims, wherein the temperature dependent shape changing material of the actuation means (22) is inductively heatable, preferably being made from ferromagnetic material.
6. Device according to claim 5, wherein outside of the drum (14, 114) an induction heating device (40) is fixedly positioned being placed so as for the actuation device (22) to pass by radially inward of the induction heating device (40).
7. Device according to one of the preceding claims, wherein the protrusion (19, 119) is made from elastic and flexible material in a form of a trough with two longitudinal end edges, wherein the protrusion is fixed to the inside of the drum (14, 114) with the two end edges such that in an initial state of the protrusion, the protrusion has a certain initial height (h1) and a certain initial profile, wherein in at least a further state of the protrusion (119) the height is diminished and the protrusion is flexed laterally to the side along a circumferential direction of the drum, wherein preferably in an initial state of the protrusion, the protrusion is symmetrical in its profile when viewed from the side, wherein in at least a further state of the protrusion the protrusion is flexed laterally to the side for between 1 cm and 3 cm.
8. Method for operating a laundry treating device (11) according to one of the preceding claims, wherein:
- in a first step, various reference curves for the drive current are recorded with a variation of the shape of the protrusion (19),
 - wherein for each reference curve for the drive current the shape of the protrusion (19) is being varied
 - the reference curves for the drive current are being stored in the storage of the processing means
 - in a second step, when laundry (30) is put into the drum (14, 114) and is actually about to be treated, testing is performed as the second step before starting the treatment of the laundry by varying the shape of the protrusion (19, 119), wherein after a comparison is made with the various reference curves for the drive current stored in the storage to determine at least one variable of the following group: weight of the laundry, typical size of pieces of laundry, major fibre portion
- of the laundry,
- in a third step, the actual treatment of the laundry (30) in the laundry treating device (11) is adapted to the weight of the laundry, the typical size of pieces of laundry and/or the major fibre portion of the laundry.
9. Method according to claim 8, wherein variables of the laundry treating process are adapted to the kind of laundry (30) or to the major fibre portion of the laundry, preferably by varying a temperature of water added to the laundry process and/or a rotation speed of the drum (14, 114) and/or varying the shape of the protrusion (19, 119).
10. Method according to one of the claims 8 or 9, wherein by supervising the drive current supplied to the drive motor (16) a force is measured when pieces of laundry (30) slide down in the drum (14, 114) along the inside of the circumferential drum wall while the drum is rotating.
11. Method according to claim 10, wherein in addition to measuring the force or the current supplied to the drive motor (16), respectively, the position of the at least one protrusion (19, 119) is determined and taken into account by reading out the information of the rotation position sensor means.
12. Method according to one of the claims 8 to 11, wherein additional information input is received by a water level sensor or by a water amount sensor in the drum (14, 114) and/or by a temperature sensor for the water temperature.
13. Method according to one of the claims 8 to 12, wherein varying the shape of the protrusion (19, 119) in the first step and/or in the second step includes flexing the protrusion from a maximum into one direction along the circumferential direction of the drum (14, 114) to a maximum into the opposite direction along the circumferential direction of the drum, wherein preferably the flexing between the two maxima is being made in steps, in particular in at least three steps.

Patentansprüche

1. Wäschebehandlungsvorrichtung (11), insbesondere eine Waschmaschine oder ein Wäschetrockner, mit:
- einer drehbaren Trommel (14, 114) mit einer Trommelumfangswand zum Einlegen der Wäsche (30),
 - einem Antriebsmotor (16) für die Trommel (14, 114),

- mindestens einem Vorsprung (19, 119) an einer Innenseite der Trommelumfangswand, wobei
- der Vorsprung (19, 119) in seiner Höhe über die Innenseite der Trommelumfangswand variabel und/oder beweglich oder flexibel ist, und/oder der Vorsprung in seiner äußeren Form variabel und/oder beweglich oder flexibel ist,
- Betätigungsmittel (22) vorgesehen sind, um eine Änderung der Höhe oder Form des Vorsprungs (19, 119) zu bewirken,
- eine Leistungssteuerungseinheit (32) zur Versorgung des Antriebsmotors (16) mit einem Antriebsstrom,
- Stromsensormittel (35) zum Überwachen des dem Antriebsmotor (16) zugeführten Antriebsstroms,
- eine Gerätesteuerung (34) mit einer Recheneinrichtung zur Berechnung einer Drehposition der Trommel (14, 114) und/oder eines Antriebsstroms aus den jeweiligen Sensormitteln (35) vorgesehen ist,

gekennzeichnet durch:

- Drehpositionssensormittel zum Überwachen einer Drehposition der Trommel (14, 114),
 - in der Recheneinrichtung ein Speicher vorgesehen ist, in dem verschiedene Gruppen von Diagrammen gespeichert sind, die für eine Abhängigkeit des Antriebsstroms der Ladung (30) in der Trommel (14, 114) sowie des Hauptfaseranteils der Wäsche (30) repräsentativ sind, wobei die Diagramme eine Variation des Antriebsstroms in Abhängigkeit von der Form des Vorsprungs (19, 119) aufweisen, der variiert wird,
 - die Recheneinrichtung geeignet ist, die Ladung oder das Gewicht der Wäsche (30) in der Trommel (14, 114), die typische Größe der Wäschestücke (30) in der Trommel (14, 114) und/oder den Hauptfaseranteil der Wäsche (30) zu berechnen.
2. Vorrichtung nach Anspruch 1, wobei die Recheneinrichtung dazu eingerichtet ist, die Beladung oder das Gewicht der Wäsche (30) in der Trommel (14, 114) und/oder den Hauptfaseranteil der Wäsche (30) zu berechnen, um Parameter eines weiteren Wäschebehandlungsverfahrens an die erfasste Beladung und/oder den Hauptfaseranteil anzupassen, vorzugsweise im Hinblick auf die Temperatur des Wassers, die Drehgeschwindigkeit der Trommel (14, 114) oder die Form des mindestens einen Vorsprungs (19, 119).
 3. Vorrichtung nach einem der vorhergehenden Ansprüche, wobei das Betätigungsmittel (22) zur Veränderung der Höhe oder Form des Vorsprungs (19, 119) eine passive Betätigungseinrichtung (22) ist, vorzugsweise mit einem temperaturabhängigen formverändernden Material in Form einer Feder oder eines Schaums oder eines Stabes (20).
 4. Vorrichtung nach Anspruch 3, wobei die Betätigungseinrichtung (22) derart formveränderlich ist, dass bei einer Temperatur unter 30 °C eine erste Form vorliegt und dass bei einer Temperatur über 30 °C eine zweite Form vorliegt, wobei vorzugsweise über 40 °C eine dritte Form vorliegt.
 5. Vorrichtung nach einem der vorhergehenden Ansprüche, wobei das temperaturabhängig formverändernde Material der Betätigungseinrichtung (22) induktiv beheizbar ist, vorzugsweise aus ferromagnetischem Material besteht.
 6. Vorrichtung nach Anspruch 5, wobei außerhalb der Trommel (14, 114) eine Induktionsheizvorrichtung (40) fest positioniert ist, die so angeordnet ist, dass die Betätigungseinrichtung (22) radial einwärts an der Induktionsheizvorrichtung (40) vorbei läuft.
 7. Vorrichtung nach einem der vorhergehenden Ansprüche, wobei der Vorsprung (19, 119) aus elastischem und flexiblem Material in Form einer Wanne mit zwei längsverlaufenden Endkanten hergestellt ist, wobei der Vorsprung mit den beiden Endkanten an der Innenseite der Trommel (14, 114) derart befestigt ist, dass in einem Ausgangszustand des Vorsprungs der Vorsprung eine bestimmte Ausgangshöhe (h1) und ein bestimmtes Ausgangsprofil aufweist, wobei in mindestens einem weiteren Zustand des Vorsprungs (119) die Höhe verringert ist und der Vorsprung seitlich zur Seite entlang einer Umfangsrichtung der Trommel gebogen ist, wobei vorzugsweise in einem Ausgangszustand des Vorsprungs der Vorsprung in seinem Profil von der Seite gesehen symmetrisch ist, wobei in mindestens einem weiteren Zustand des Vorsprungs der Vorsprung seitlich zur Seite zwischen 1 cm und 3 cm gebogen ist.
 8. Verfahren zum Betreiben einer Wäschebehandlungsvorrichtung (11) nach einem der vorhergehenden Ansprüche, wobei:
 - in einem ersten Schritt verschiedene Referenzkurven für den Antriebsstrom mit einer Variation der Form des Vorsprungs (19) aufgenommen werden,
 - wobei für jede Referenzkurve für den Antriebsstrom die Form des Vorsprungs (19) variiert wird,
 - die Referenzkurven für den Antriebsstrom in dem Speicher der Recheneinrichtung gespeichert werden,

- in einem zweiten Schritt, wenn Wäsche (30) in die Trommel (14, 114) eingelegt wird und tatsächlich behandelt werden soll, als zweiter Schritt vor Beginn der Behandlung der Wäsche ein Test durchgeführt wird, indem die Form des Vorsprungs (19, 119) verändert wird, wobei danach ein Vergleich mit den verschiedenen im Speicher gespeicherten Referenzkurven für den Antriebsstrom durchgeführt wird, um mindestens eine Variable der folgenden Gruppe zu bestimmen: Gewicht der Wäsche, typische Größe der Wäschestücke, Hauptfaseranteil der Wäsche,
- in einem dritten Schritt wird die eigentliche Behandlung der Wäsche (30) in der Wäschebehandlungsvorrichtung (11) an das Gewicht der Wäsche, die typische Größe der Wäschestücke und/oder den Hauptfaseranteil der Wäsche angepasst.
9. Verfahren nach Anspruch 8, wobei Variablen des Wäschebehandlungsprozesses an die Art der Wäsche (30) oder an den Hauptfaseranteil der Wäsche angepasst werden, vorzugsweise durch Variieren einer Temperatur des dem Wäscheprozess zugeführten Wassers und/oder einer Drehgeschwindigkeit der Trommel (14, 114) und/oder Variieren der Form des Vorsprungs (19, 119).
10. Verfahren nach einem der Ansprüche 8 oder 9, wobei durch Überwachen des dem Antriebsmotor (16) zugeführten Antriebsstroms eine Kraft gemessen wird, wenn Wäschestücke (30) in der Trommel (14, 114) entlang der Innenseite der Trommelumfangswand nach unten rutschen, während sich die Trommel dreht.
11. Verfahren nach Anspruch 10, wobei zusätzlich zur Messung der Kraft bzw. des dem Antriebsmotor (16) zugeführten Stroms die Position des mindestens einen Vorsprungs (19, 119) durch Auslesen der Information des Drehpositionssensors ermittelt und berücksichtigt wird.
12. Verfahren nach einem der Ansprüche 8 bis 11, wobei zusätzliche Informationen von einem Wasserstandssensor oder von einem Wassermengensensor in der Trommel (14, 114) und/oder von einem Temperatursensor für die Wassertemperatur eingegeben werden.
13. Verfahren nach einem der Ansprüche 8 bis 12, wobei das Verändern der Form des Vorsprungs (19, 119) im ersten Schritt und/oder im zweiten Schritt ein Verbiegen des Vorsprungs von einem Maximum in eine Richtung entlang der Umfangsrichtung der Trommel (14, 114) zu einem Maximum in die entgegengesetzte Richtung entlang der Umfangsrichtung der Trom-

mel umfasst, wobei vorzugsweise das Verbiegen zwischen den beiden Maxima in Schritten, insbesondere in mindestens drei Schritten, erfolgt.

Revendications

1. Dispositif de traitement du linge (11), en particulier une machine à laver ou un séchoir à linge, comportant :

- un tambour rotatif (14, 114) ayant une paroi périphérique pour y placer le linge (30),
- un moteur d'entraînement (16) pour le tambour (14, 114),
- au moins une protubérance (19, 119) à l'intérieur de la paroi périphérique du tambour, dans laquelle
- la protubérance (19, 119) est variable et/ou mobile ou flexible dans sa hauteur sur l'intérieur de la paroi périphérique du tambour, et/ou la protubérance est variable et/ou mobile ou flexible dans sa forme extérieure,
- des moyens d'actionnement (22) sont prévus pour modifier la hauteur ou la forme de la protubérance (19, 119),
- une unité de commande de puissance (32) pour fournir un courant d'entraînement au moteur d'entraînement (16),
- des moyens de détection de courant (35) pour surveiller le courant d'entraînement fourni au moteur d'entraînement (16),
- un dispositif de commande (34) est prévu avec un moyen de traitement pour calculer une position de rotation du tambour (14, 114) et/ou un courant d'entraînement à partir des moyens de détection respectifs (35),

caractérisé par :

- un moyen de détection de la position de rotation pour surveiller la position de rotation du tambour (14, 114),
- le moyen de traitement comporte une mémoire dans laquelle sont stockés divers groupes de diagrammes représentatifs d'une dépendance du courant d'entraînement du linge (30) dans le tambour (14, 114) ainsi que de la principale partie fibreuse du linge (30), les diagrammes présentant une variation du courant d'entraînement en fonction de la forme de la protubérance (19, 119) qui est modifiée,
- le moyen de traitement est adapté pour calculer la charge ou le poids du linge (30) dans le tambour (14, 114), la taille typique des pièces de linge (30) dans le tambour (14, 114) et/ou la majeure partie des fibres du linge (30).

2. Dispositif selon la revendication 1, dans lequel le moyen de traitement est adapté pour calculer la charge ou le poids du linge (30) dans le tambour (14, 114) et/ou la partie principale du linge (30) pour adapter les paramètres d'une autre procédure de traitement du linge à la charge détectée et/ou à la partie principale du linge, de préférence en ce qui concerne la température de l'eau, la vitesse de rotation du tambour (14, 114) ou la forme d'au moins une protubérance (19, 119).
3. Dispositif selon l'une des revendications précédentes, dans lequel le moyen d'actionnement (22) pour modifier la hauteur ou la forme de la protubérance (19, 119) est un dispositif d'actionnement passif (22), en particulier avec un matériau à changement de forme dépendant de la température sous la forme d'un ressort ou d'une mousse ou d'une tige (20).
4. Dispositif selon la revendication 3, dans lequel le dispositif d'actionnement (22) est à forme variable de sorte qu'une première forme est présente à une température inférieure à 30 °C et qu'une deuxième forme est présente à une température supérieure à 30 °C, une troisième forme étant de préférence présente à une température supérieure à 40 °C.
5. Dispositif selon l'une des revendications précédentes, dans lequel le matériau à changement de forme en fonction de la température du moyen d'actionnement (22) est chauffé par induction, de préférence en matériau ferromagnétique.
6. Dispositif selon la revendication 5, dans lequel, à l'extérieur du tambour (14, 114), un dispositif de chauffage par induction (40) est positionné de manière fixe et placé de façon à ce que le dispositif d'actionnement (22) passe radialement à l'intérieur du dispositif de chauffage par induction (40).
7. Dispositif selon l'une des revendications précédentes, dans lequel la protubérance (19, 119) est fabriquée à partir d'un matériau élastique et flexible sous la forme d'une gouttière avec deux bords d'extrémité longitudinaux, dans lequel la protubérance est fixée à l'intérieur du tambour (14, 114) avec les deux bords d'extrémité de telle sorte que dans un état initial de la protubérance, la protubérance a une certaine hauteur initiale (h1) et un certain profil initial, dans lequel, dans au moins un autre état de la protubérance (119), la hauteur est diminuée et la protubérance est fléchie latéralement le long de la direction circonférentielle du tambour, dans lequel, de préférence, dans un état initial de la protubérance, la protubérance est symétrique dans son profil lorsqu'elle est vue de côté, dans lequel, dans au moins un autre état de la protubérance, la protubérance est fléchie latéralement sur une distance comprise entre 1 cm et 3 cm.
8. Procédé de fonctionnement d'un dispositif de traitement du linge (11) selon l'une des revendications précédentes, dans lequel :
- dans une première étape, diverses courbes de référence pour le courant d'entraînement sont enregistrées avec une variation de la forme de la protubérance (19),
 - pour chaque courbe de référence du courant d'entraînement, la forme de la protubérance (19) est modifiée,
 - les courbes de référence du courant d'entraînement sont stockées dans la mémoire des moyens de traitement,
 - dans une deuxième étape, lorsque le linge (30) est placé dans le tambour (14, 114) et qu'il est sur le point d'être traité, un test est effectué dans une deuxième étape avant de commencer le traitement du linge en faisant varier la forme de la protubérance (19, 119), après quoi une comparaison est effectuée avec les différentes courbes de référence pour le courant d'entraînement stockées dans la mémoire afin de déterminer au moins une variable du groupe suivant : le poids du linge, la taille typique des pièces de linge, la partie principale des fibres du linge,
 - dans une troisième étape, le traitement effectif du linge (30) dans le dispositif de traitement du linge (11) est adapté au poids du linge, à la taille typique des pièces de linge et/ou à la majeure partie des fibres du linge.
9. Procédé selon la revendication 8, dans laquelle les variables du processus de traitement du linge sont adaptées au type de linge (30) ou à la partie fibreuse principale du linge, de préférence en faisant varier la température de l'eau ajoutée au processus de traitement du linge et/ou la vitesse de rotation du tambour (14, 114) et/ou la forme de la protubérance (19, 119).
10. Procédé selon l'une des revendications 8 ou 9, dans lequel, en surveillant le courant d'entraînement fourni au moteur d'entraînement (16), une force est mesurée lorsque les pièces de linge (30) glissent dans le tambour (14, 114) le long de l'intérieur de la paroi périphérique du tambour pendant que le tambour est en rotation.
11. Procédé selon la revendication 10, dans lequel, en plus de la mesure de la force ou du courant fourni au moteur d'entraînement (16), respectivement, la position d'au moins une protubérance (19, 119) est déterminée et prise en compte par la lecture des informations du moyen de détection de la position de rotation.

12. Procédé selon l'une des revendications 8 à 11, dans lequel l'entrée d'informations supplémentaires est reçue par un capteur de niveau d'eau ou par un capteur de quantité d'eau dans le tambour (14, 114) et/ou par un capteur de température pour la température de l'eau. 5

13. Procédé selon l'une des revendications 8 à 12, dans laquelle la variation de la forme de la protubérance (19, 119) dans la première étape et/ou dans la deuxième étape comprend la flexion de la protubérance d'un maximum dans une direction le long de la direction circonférentielle du tambour (14, 114) à un maximum dans la direction opposée le long de la direction circonférentielle du tambour, dans laquelle de préférence la flexion entre les deux maxima est effectuée par étapes, en particulier en au moins trois étapes. 10 15

20

25

30

35

40

45

50

55

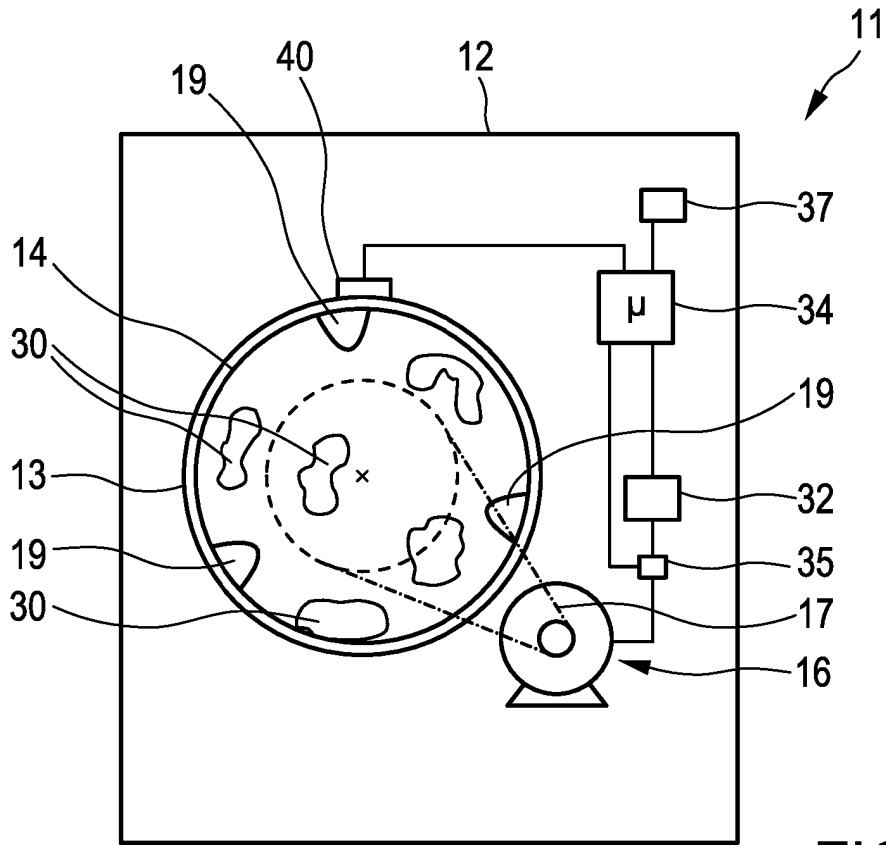

FIG. 1

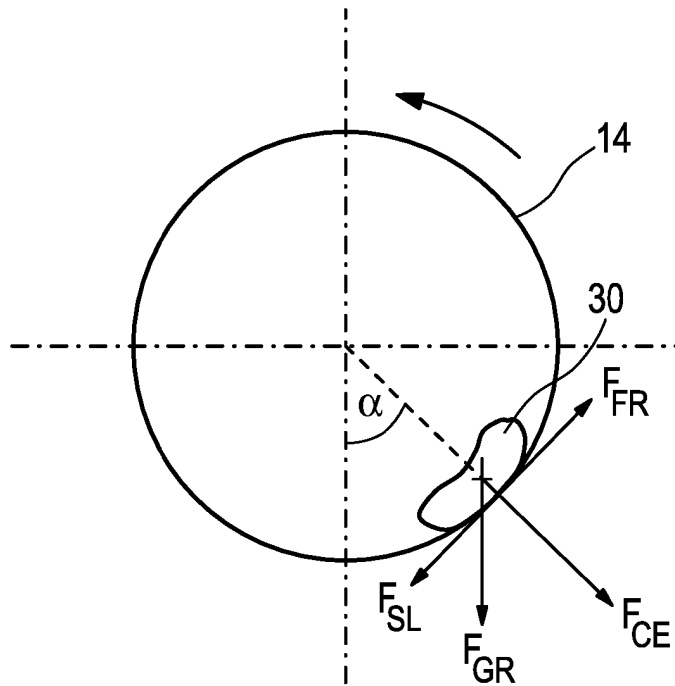

FIG. 2

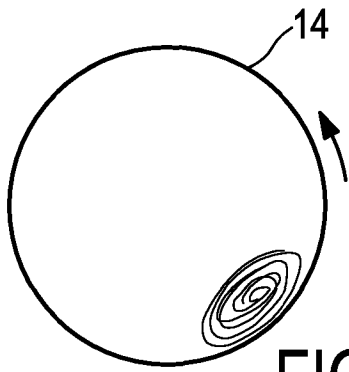

FIG. 3A

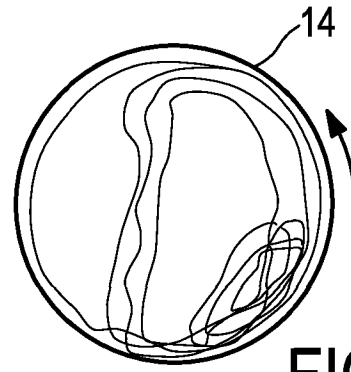

FIG. 3B

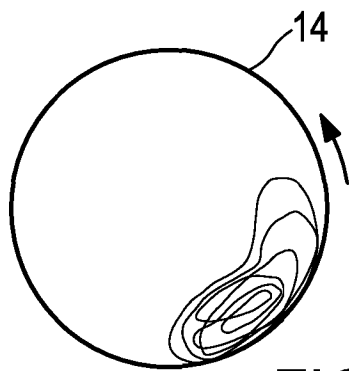

FIG. 3C

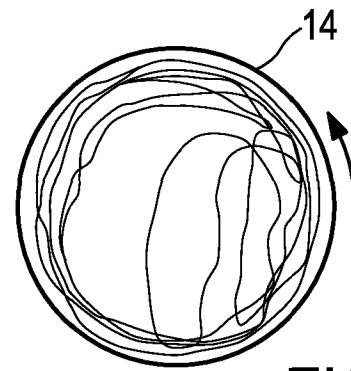

FIG. 3D

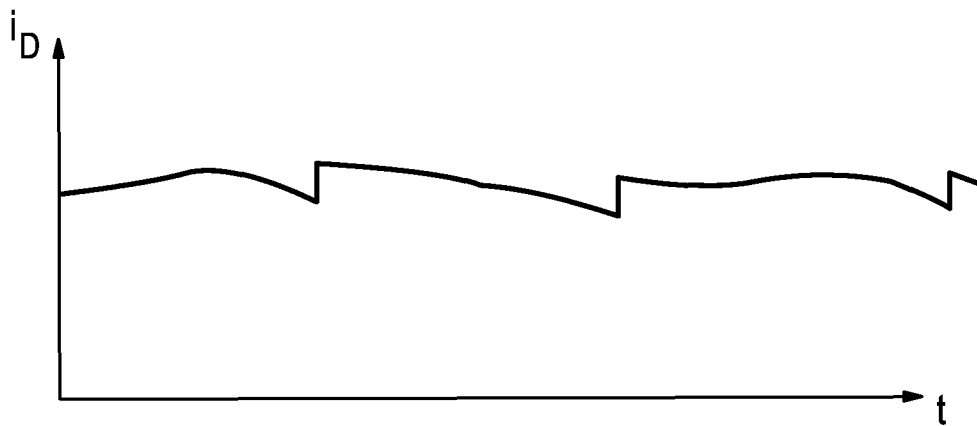
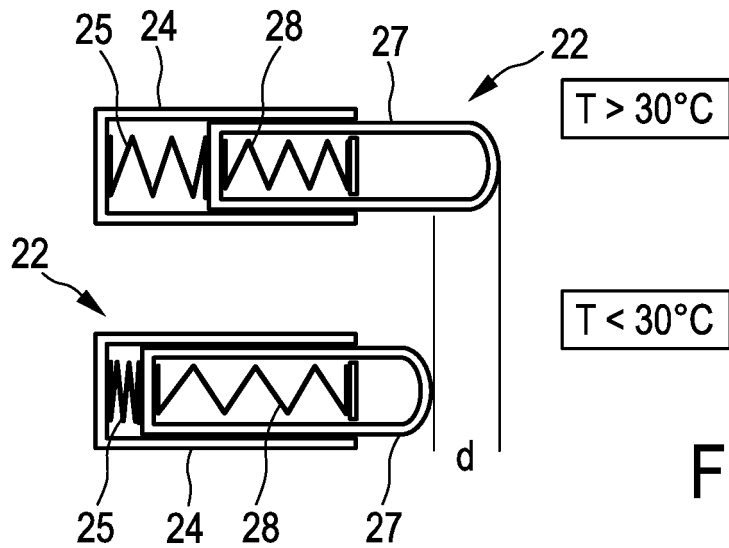
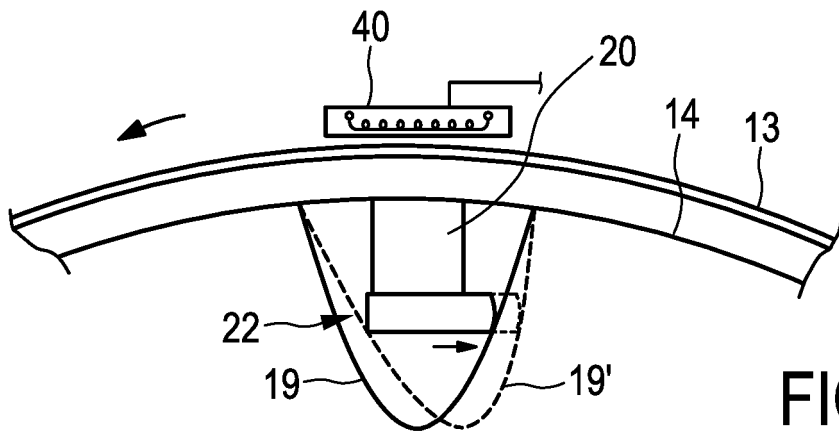
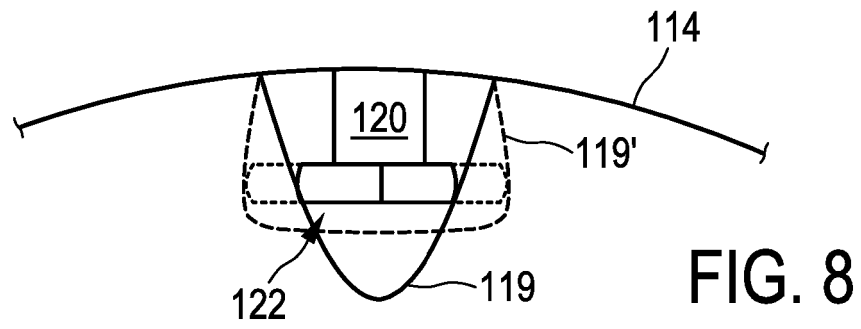
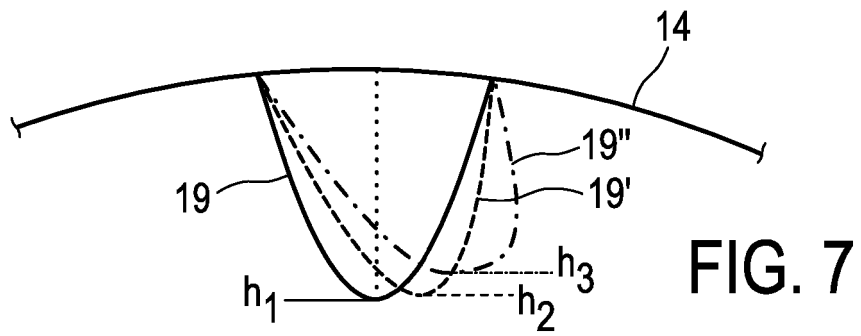

FIG. 4





REFERENCES CITED IN THE DESCRIPTION

This list of references cited by the applicant is for the reader's convenience only. It does not form part of the European patent document. Even though great care has been taken in compiling the references, errors or omissions cannot be excluded and the EPO disclaims all liability in this regard.

Patent documents cited in the description

- JP 2007159892 A [0003]
- EP 3312332 A1 [0004]
- US 3938260 A [0005]
- EP 2524989 A1 [0006]