



- (51) International Patent Classification:
F02B 37/12 (2006.01) F02D 23/00 (2006.01)
F02B 39/00 (2006.01)
- (21) International Application Number:
PCT/US2012/020721
- (22) International Filing Date:
10 January 2012 (10.01.2012)
- (25) Filing Language: English
- (26) Publication Language: English
- (30) Priority Data:
10 2011009 610.8
27 January 2011 (27.01.2011) DE
- (71) Applicant (for all designated States except US):
BORGWARNER INC. [US/US]; Patent Department,
3850 Hamlin Road, Auburn Hills, Michigan 48326 (US).
- (72) Inventor; and
- (75) Inventor/Applicant (for US only): **GROSSMANN, Stefan** [DE/DE]; St. Urban Str. 4, 67550 Worms (DE).
- (74) Agents: **PENDORF, Stephan A.** et al.; Patent Central LLC, 1401 Hollywood Boulevard, Hollywood, Florida 33020-5237 (US).

- (81) Designated States (unless otherwise indicated, for every kind of national protection available): AE, AG, AL, AM, AO, AT, AU, AZ, BA, BB, BG, BH, BR, BW, BY, BZ, CA, CH, CL, CN, CO, CR, CU, CZ, DE, DK, DM, DO, DZ, EC, EE, EG, ES, FI, GB, GD, GE, GH, GM, GT, HN, HR, HU, ID, IL, IN, IS, JP, KE, KG, KM, KN, KP, KR, KZ, LA, LC, LK, LR, LS, LT, LU, LY, MA, MD, ME, MG, MK, MN, MW, MX, MY, MZ, NA, NG, NI, NO, NZ, OM, PE, PG, PH, PL, PT, QA, RO, RS, RU, RW, SC, SD, SE, SG, SK, SL, SM, ST, SV, SY, TH, TJ, TM, TN, TR, TT, TZ, UA, UG, US, UZ, VC, VN, ZA, ZM, ZW.
- (84) Designated States (unless otherwise indicated, for every kind of regional protection available): ARIPO (BW, GH, GM, KE, LR, LS, MW, MZ, NA, RW, SD, SL, SZ, TZ, UG, ZM, ZW), Eurasian (AM, AZ, BY, KG, KZ, MD, RU, TJ, TM), European (AL, AT, BE, BG, CH, CY, CZ, DE, DK, EE, ES, FI, FR, GB, GR, HR, HU, IE, IS, IT, LT, LU, LV, MC, MK, MT, NL, NO, PL, PT, RO, RS, SE, SI, SK, SM, TR), OAPI (BF, BJ, CF, CG, CI, CM, GA, GN, GQ, GW, ML, MR, NE, SN, TD, TG).

Declarations under Rule 4.17:

— as to applicant's entitlement to apply for and be granted a patent (Rule 4.17(ii))

[Continued on next page]

(54) Title: REGULATING FLAP ARRANGEMENT

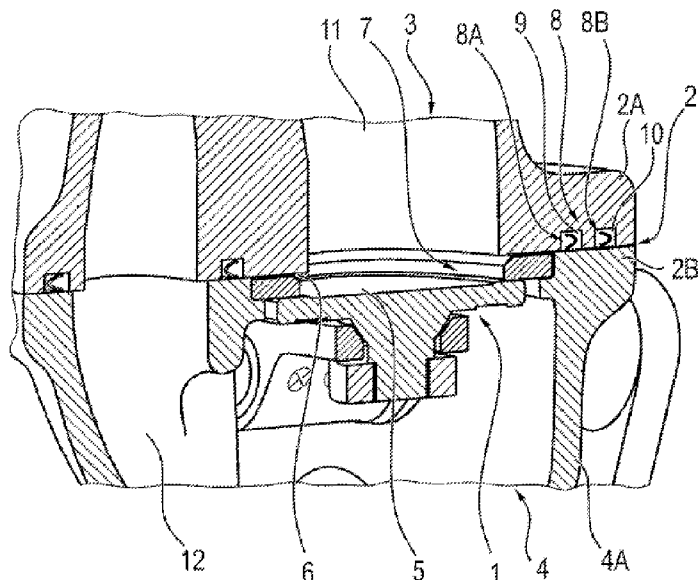

FIG. 1

(57) Abstract: The invention relates to a regulating flap arrangement (1) in a flange connection (2) between a turbine housing of a two-stage exhaust-gas turbocharger and an exhaust manifold of an engine, having a regulating flap plate (5) which is pivotable between an open position and a closed position for opening and closing a connecting opening (6) arranged in the flange connection (2); having an insert ring (7) which is arranged in the connecting opening (6); and having a sealing arrangement (8), wherein the sealing arrangement (8) has two V-rings (8A, 8B), of which a first V-ring (8A) is arranged in a first groove (9) provided adjacent to the connecting opening (6), and the second V-ring (8B) is arranged in a second groove (10) which is arranged, spaced apart radially outward from the first groove (9), in the flange connection (2).

- *as to the applicant's entitlement to claim the priority of the earlier application (Rule 4.17(iii))*
 - *of inventorship (Rule 4.17(iv))*
- Published:**
- *without international search report and to be republished upon receipt of that report (Rule 48.2(g))*

REGULATING FLAP ARRANGEMENT

DESCRIPTION

5 The invention relates to a regulating flap arrangement as per the preamble of claim 1.

A regulating flap arrangement of said type may be provided in a flange connection between a turbine housing of an exhaust-gas turbocharger and an exhaust manifold of an engine. In particular, such a regulating flap arrangement may be provided between the turbine housing of a low-pressure turbine of a two-stage turbocharger arrangement and the exhaust manifold of an engine. Said exhaust manifold may be an exhaust manifold module with a high-pressure turbine housing integrated therein or attached thereto by screw connection. In the case of a known regulating flap arrangement, the sealing in the region of the flange connections is realized by means of a crimp seal, which is however of very cumbersome design because a large number of screws are required. Furthermore, said crimp seal causes problems from a space aspect in the packaging of the overall arrangement.

15 It is therefore an object of the present invention to provide a regulating flap arrangement of the type specified in the preamble of claim 1, which makes it possible to dispense with a cumbersome crimp seal.

20 Said object is achieved by means of the features of claim 1.

According to said solution, a sealing arrangement is provided which has two V-rings arranged radially spaced apart from one another in the flange connection. For this purpose, the first V-ring is arranged in a groove provided adjacent to the connecting opening between the turbine housing of a low-pressure turbine and the exhaust manifold. The second V-ring is arranged in a second groove which, as viewed from the central point of the connecting opening, is arranged, spaced apart radially outward from the first groove, in the flange connection.

The subclaims relate to advantageous refinements of the invention.

30 The first groove of the seal arrangement may be arranged either in the flange connection or in an insert ring which is arranged in the connecting opening and which forms, and seals off at both sides, the seat of the regulating flap plate of the regulating flap arrangement.

35 If the first groove is provided in the flange connection, said groove may, depending on what type of flange connection is involved, be arranged in a flange of the turbine housing or in a flange of the exhaust manifold which is connected to the turbine housing.

If the regulating flap arrangement according to the invention is used in a two-stage turbocharger arrangement, the groove may be arranged either in a flange of the housing of the low-pressure turbine or in a flange of the exhaust manifold of the engine.

5 Said second groove of the regulating flap arrangement according to the invention is arranged, in the same way as the first groove, in the flange.

In all alternative possible arrangements, the provision of the V-rings in grooves yields the advantage in each case that the V-rings are protected against an excessive introduction of heat by the ridge of the groove situated adjacent to the connecting opening in each case.

It is also possible for the one or more V-rings to each be under preload.

The regulating flap plate is preferably of circular design.

Further details, features and advantages of the invention will emerge from the following description of exemplary embodiments on the basis of the drawing, in which:

15 figures 1 and 2 show a first embodiment of the regulating flap arrangement according to the invention,

figures 3 to 5 show a second embodiment of the regulating flap arrangement according to the invention, and

20 figure 6 shows a perspective illustration of a two-stage turbocharger arrangement.

Figures 1 and 2 illustrate a regulating flap arrangement 1 in a flange connection 2, which regulating flap arrangement is used, in the example, in a two-stage turbocharger arrangement. Of said two-stage turbocharger arrangement, figures 1 and 2 show an exhaust manifold 3 with an outlet duct and a low-pressure turbine 4 with a turbine housing 4A.

25 The exhaust manifold 3 has a flange 2A and the turbine housing 4A has a flange 2B, which flanges form the flange connection 2.

The regulating flap arrangement 1 according to figures 1 and 2 also has a regulating flap plate 5 which is pivotable between an open position and a closed position, wherein figures 1 and 2 each show the closed position. The regulating flap plate 5 opens and closes a connecting opening 6 which creates a flow connection between the exhaust manifold 3 and the turbine housing 4A. Here, the connecting opening 6 is arranged in the outlet duct 11, wherein figures 1 and 2 also show a connecting duct 12 which is a constituent part of the exhaust manifold and which connects the turbine housing of the high-pressure turbine (not illustrated) to the turbine housing 4A of the low-pressure turbine 4, as can be seen in detail from the diagrammatic illustration of figures 1 and 2.

Figures 1 and 2 also show that the regulating flap plate 5 is arranged in the outlet duct 11 on the side of the low-pressure turbine housing 4A.

Arranged in the connecting opening 6 is an insert ring 7 which, in the closed position shown in figures 1 and 2, interacts with the regulating flap plate 5 in order to seal off the outlet duct 11, as can be seen in particular from the sectional illustration of figure 1.

Furthermore, the regulating flap 1 according to the invention has a sealing arrangement 8, which according to the invention comprises two V-rings 8A and 8B.

The V-ring 8A is arranged in a groove 9 which, in the example, is arranged in the flange 2A and is provided adjacent to the connecting opening 6.

A second groove 10 is formed in the flange 2A radially to the outside of said first groove 9, in which second groove is arranged the second V-ring 8B of the sealing arrangement 8. As a result of this arrangement, it is achieved that the inner V-ring 8A or the inner V-ring seal separates the outlet duct 11 and the connecting duct 12 from one another, while the outer V-ring 8B or the outer V-ring seal serves to seal off the entire flange connection 2 to the outside.

As explained in the introduction, the grooves arranged in the flange 2A in the example could however also in principle be arranged in the flange 2B.

The second embodiment of the regulating flap arrangement 1 can be seen from a juxtaposition of figures 3 to 5. All parts corresponding to the embodiment of figures 1 and 2 are provided with the same reference numerals, such that in this regard, reference can be made to the above explanation of figures 1 and 2.

The difference between the two embodiments is that the inner V-ring seal or the V-ring 8A is provided in the insert ring 7, such that the first groove 9 is accordingly arranged in said insert ring 7. This can be clearly seen in particular from the enlarged detail view of figure 5. In addition to the advantage that it is possible to obtain a sealing action to the outside which is improved in relation to the prior art, which advantage is also inherent in the embodiment according to figures 1 and 2, the embodiment according to figures 3 to 5 yields the further advantage of a radial space saving as a result of the arrangement of the V-ring 8A in the insert ring 7.

Both embodiments yield a simplification of the design as a result of the possibility of eliminating a complicated crimp seal such as is provided in the prior art.

In the second embodiment, aside from an unchanged outer diameter and the advantage of the said space saving, it is made possible to perform monitored pre-assembly of the V-ring 8A and of the insert ring 7, as a result of which less expenditure is involved in the assembly of the exhaust manifold 3 and of the turbine housing 4A.

In both embodiments, the insert ring 7 may be under preload, which yields an improved sealing action in relation to a known crimp seal.

The resulting reduced leakage in turn advantageously yields an improved response behavior of the high-pressure stage of a two-stage turbocharger arrangement, because as a result of the improved sealing, when the regulating flap 5 is closed, there is less exhaust-gas leakage from the outlet duct 11 to the connecting duct 12, and therefore all of the exhaust gas is supplied only to the high-pressure turbine.

To supplement the disclosure, reference is made to figure 6, which shows a two-stage turbocharger arrangement EGT which is connected to the exhaust manifold 3. As is conventional, the two-stage turbocharger arrangement EGT has a high-pressure stage HP (high-pressure turbocharger) and a low-pressure stage LP (low-pressure turbocharger). A two-stage turbocharger arrangement EGT of said type self-evidently also has all the other elements of such arrangements, which however need not be described for the purposes of explaining the present invention.

In addition to the written disclosure above, reference is hereby explicitly made to the diagrammatic illustration thereof in figures 1 to 5.

LIST OF REFERENCE SYMBOLS

	1	Regulating flap arrangement
	2	Flange connection
5	2A, 2B	Flanges of the flange connection 2
	3	Exhaust manifold
	4	Low-pressure turbine
	4A	Turbine housing
	5	Regulating flap plate
10	6	Connecting opening
	7	Insert ring
	8	Sealing arrangement
	8A, 8B	V-rings / V-ring seals
	9, 10	Grooves
15	11	Outlet duct
	12	Connecting duct
	13	High-pressure turbine
	EGT	Two-stage exhaust-gas turbocharger arrangement
	HP	High-pressure stage
20	LP	Low-pressure stage

CLAIMS

1. A regulating flap arrangement (1) in a flange connection (2) between a turbine housing of a two-stage exhaust-gas turbocharger and an exhaust manifold of an engine,
- 5
- having a regulating flap plate (5) which is pivotable between an open position and a closed position for opening and closing a connecting opening (6) arranged in the flange connection (2);
 - having an insert ring (7) which is arranged in the connecting opening

10 (6); and

 - having a sealing arrangement (8), wherein
 - the sealing arrangement (8) has two V-rings (8A, 8B), of which a first V-ring (8A) is arranged in a first groove (9) provided adjacent to the connecting opening (6), and the second V-ring (8B) is arranged in a second groove (10) which is

15 arranged, spaced apart radially outward from the first groove (9), in the flange connection (2).
2. The regulating flap arrangement as claimed in claim 1, wherein the first groove (9) is arranged in the flange connection (2).
- 20
3. The regulating flap arrangement as claimed in claim 1 or 2, wherein the first groove (9) is arranged in a flange of the turbine housing.
4. The regulating flap arrangement as claimed in claim 3, wherein the
- 25 flange is a flange (2B) of the low-pressure turbine (4).
5. The regulating flap arrangement as claimed in claim 3, wherein the flange is a flange (2A) of the high-pressure turbine (13).
- 30
6. The regulating flap arrangement as claimed in claim 1 or 2, wherein the first groove (9) is arranged in a flange of the exhaust manifold (3).
7. The regulating flap arrangement as claimed in claim 1, wherein the first groove (9) is arranged in the insert ring (7).
- 35
8. The regulating flap arrangement as claimed in claim 1, wherein the second groove (10) is arranged in a flange of the turbine housing.

9. The regulating flap arrangement as claimed in claim 8, wherein the flange of the second groove (10) is a flange (2B) of the low-pressure turbine (4).

5 10. The regulating flap arrangement as claimed in claim 8, wherein the flange of the second groove (10) is a flange (2A) of the high-pressure turbine (13).

11. The regulating flap arrangement as claimed in claim 8, wherein the second groove (10) is arranged in a flange (2A) of the exhaust manifold (3).

10

12. The regulating flap arrangement as claimed in one of claims 1 to 11, wherein the regulating flap plate (5) is circular.

13. The regulating flap arrangement as claimed in one of claims 1 to 12,
15 wherein the insert ring (7) is under preload.

14. The regulating flap arrangement as claimed in one of claims 1 to 13, wherein the first V-ring (8A) and/or the second V-ring (8B) are/is under preload.

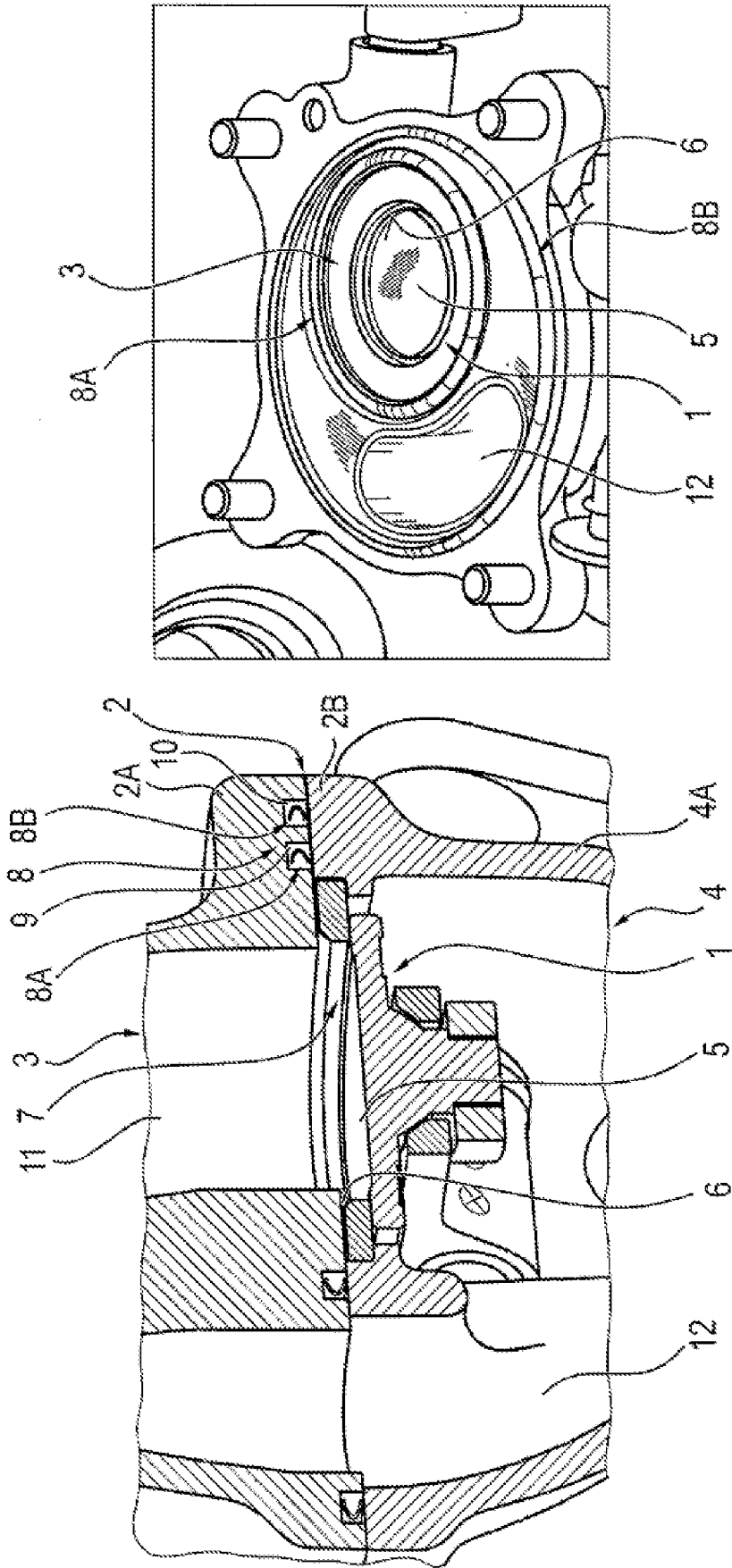

FIG. 2

FIG. 1

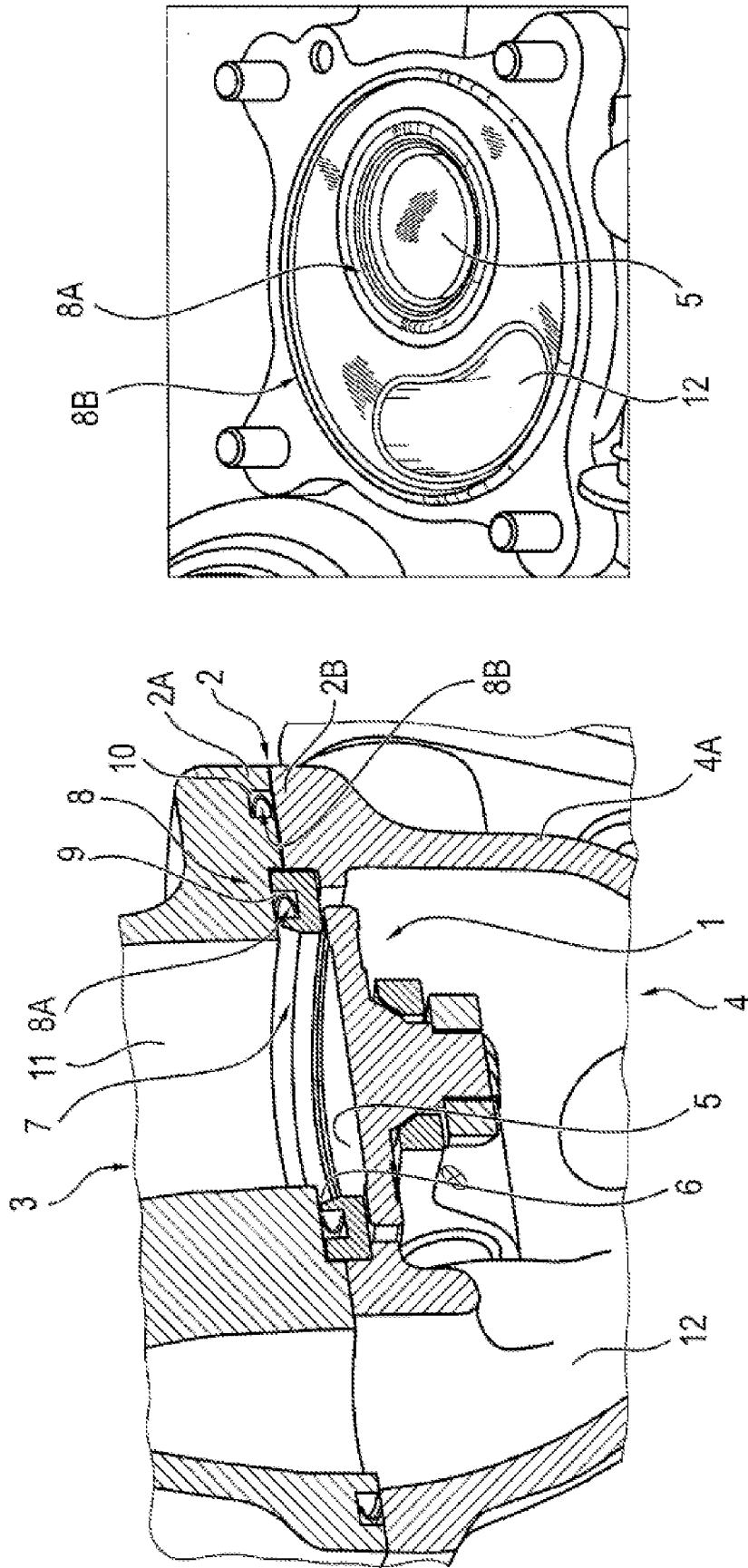

FIG. 4

FIG. 3

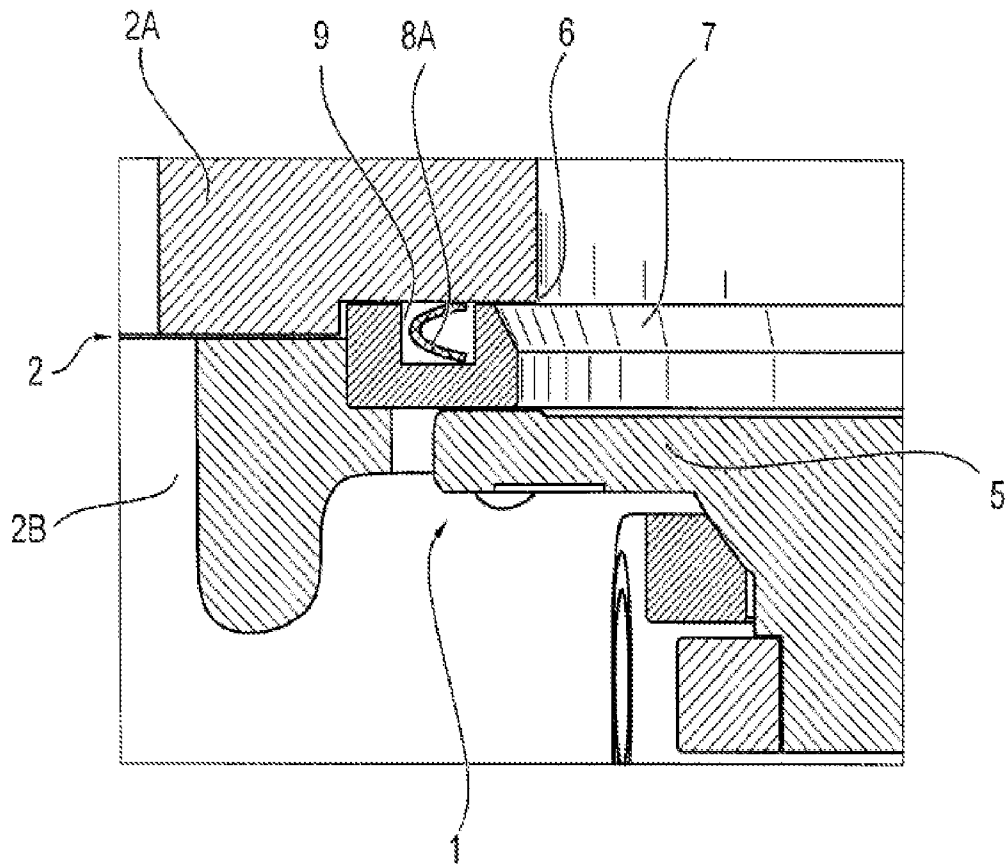

FIG. 5

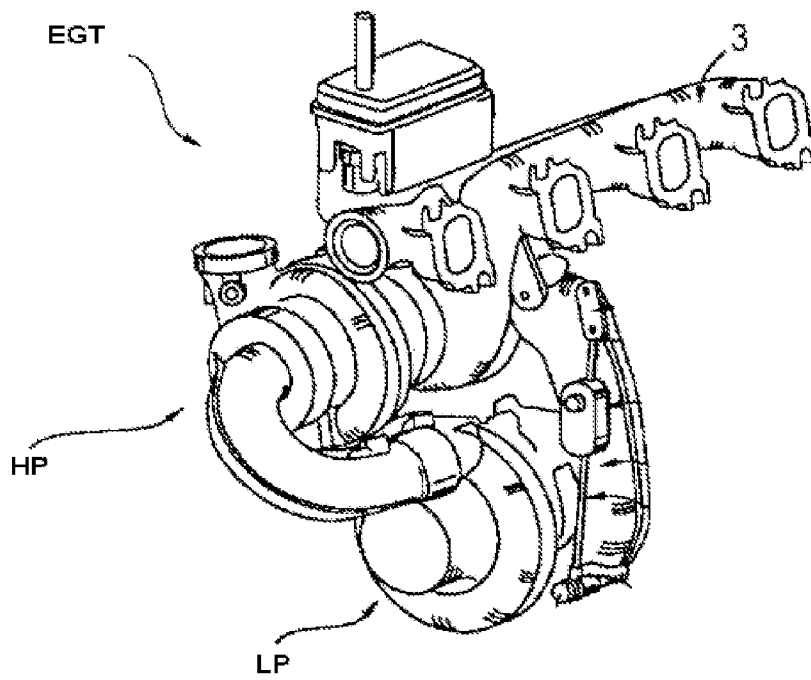

FIG. 6