

Dec. 13, 1938.

A. M. BECKER
COATING MACHINE

2,139,652

Filed May 4, 1933

2 Sheets-Sheet 1

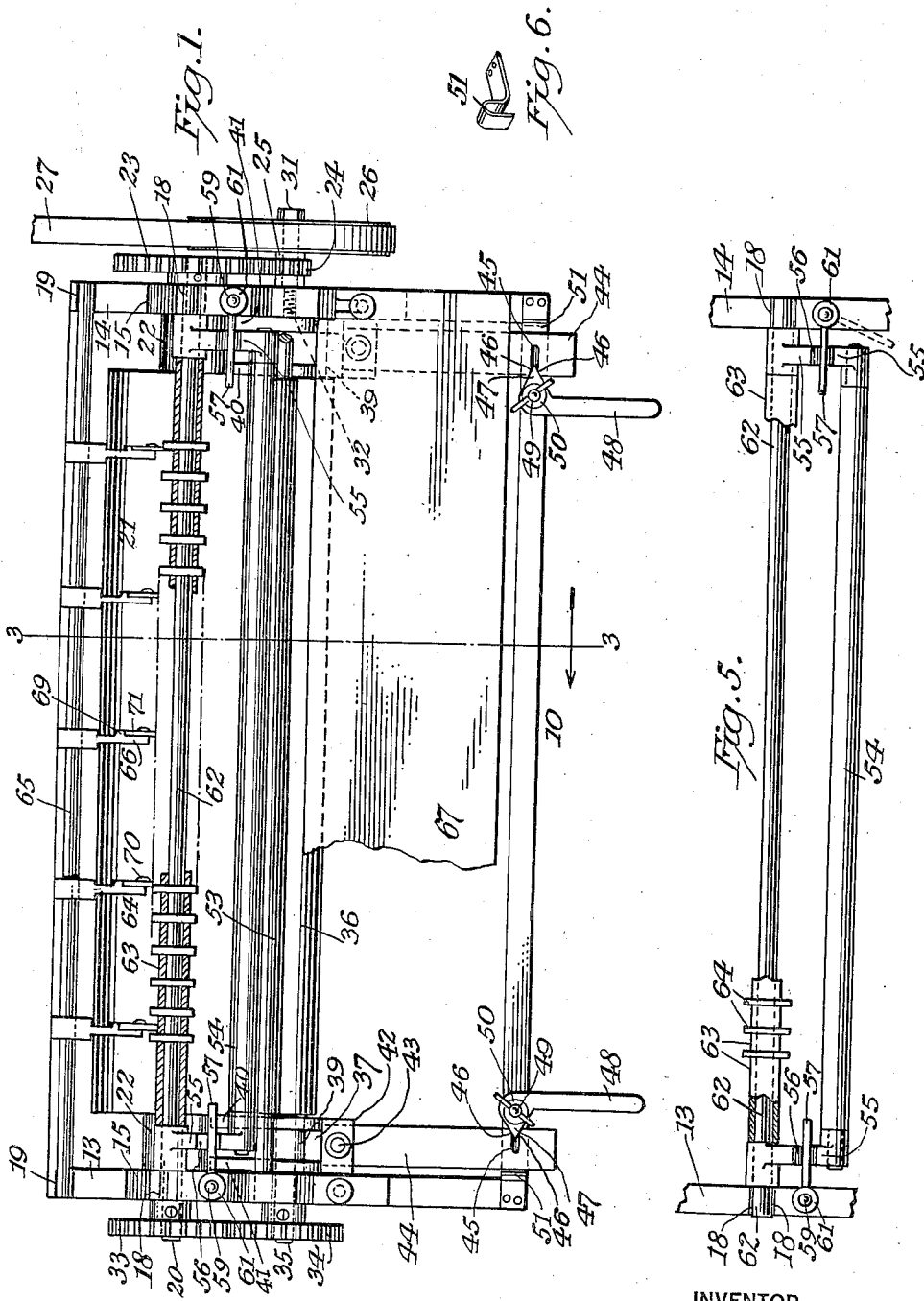

INVENTOR
August M. Becker,
BY *A. R. Appelman,*
his ATTORNEY

Dec. 13, 1938.

A. M. BECKER
COATING MACHINE

2,139,652

Filed May 4, 1930

2 Sheets-Sheet 2

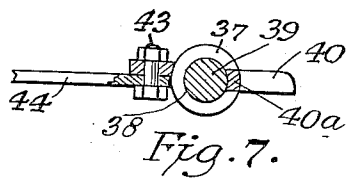
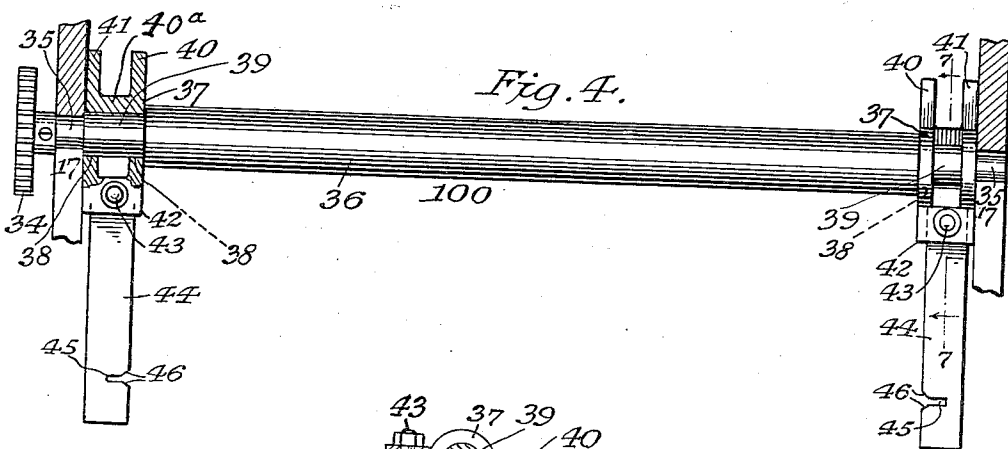
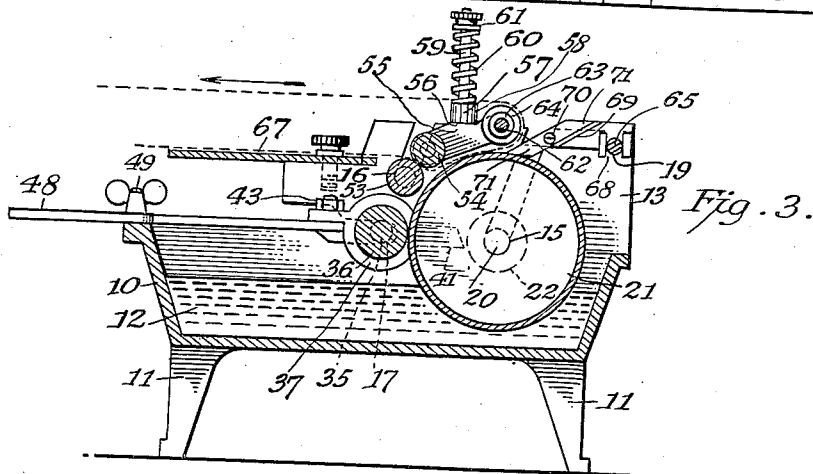
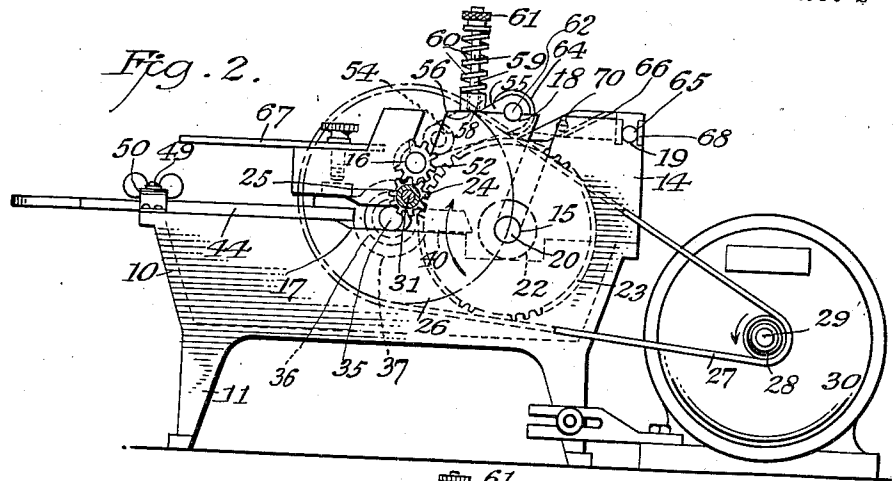

INVENTOR,
August M. Becker,
BY A. R. Appelman
His ATTORNEY.

UNITED STATES PATENT OFFICE

2,139,652

COATING MACHINE

August M. Becker, New York, N. Y., assignor to
Frank A. Becker, Cliffside, N. J.

Application May 4, 1938, Serial No. 205,942

12 Claims. (Cl. 91—51)

My present invention relates to improvements in coating machines for applying a determined film body of adhesive or other fluid or semi-fluid material to a face of a web-strip or sheet of flexible material.

The primary object of the invention is to produce improved mechanism by which certain results necessary in coating machines may be accomplished successfully by parts readily taken apart for cleaning and inspection.

A feature of the new construction will be found in presser devices for accommodating various thicknesses of sheet material fed into the machine for the coating operation.

Another feature presents simplified effective devices for regulating the adhesive film collected by a rotary applicator, to a desired thickness before reaching the object to be coated.

Another feature resides in combining parts of the device into units so that assembly and knockdown operations are facilitated.

One example being shown in a unitary presser frame rockable in an open bearing and which is free to be readily lifted from its supporting frame when desired.

Another example is found in a unitary set of scrapers readily lifted from the machine from open bearings.

Another important feature of the coating machine is present in open bearings for all shafts of the structure permitting quick knockdown and assembly for cleaning and packing for shipment.

Other inventive features will be apparent in the following description and appended claims.

In the drawings illustrating a preferred embodiment of the improved coating machine:—

Fig. 1 is a top or plan view with parts omitted and parts broken away;

Fig. 2 is an end elevation showing the powered end of the machine;

Fig. 3 is a cross section through the machine on the line 3—3 of Fig. 1;

Fig. 4 is a plan view of an adjustable scraper frame;

Fig. 5 is a detail plan view of a unitary presser frame; and

Fig. 6 is a detail perspective of a safety spring employed; and

Fig. 7 is a detail section on the line 7—7 of Fig. 4.

Referring to the drawings in detail 10 indicates a glue pan or the like mounted on legs 11, and containing a body 12 of glue or other desired or appropriate adhesive. Mounted on the

ends of the glue pan are right and left supporting plates 13 and 14 as viewed in Fig. 1, provided with a number of open bearings here designated at 15, 16, 17, 18 and 19. In the bearings 15, rest the trunnions 20 of a glue distributing drum or cylinder 21 which is provided at its ends with bosses 22 to properly space said drum between the plates 13 and 14. The right-hand or powered trunnion 20 of the drum 21, carries thereon a pinned gear 23, constantly in mesh with a driving pinion 24, connected by a hub 25, to a belt pulley 26, driven through a belt 27, by a small pulley 28, on the shaft 29, of a desired type of motor 30.

The driving pinion 24, hub 25 and belt pulley 26 are in one piece and rotate around a fixed bolt or headed pin 31, which is threaded at 32 into the adjacent supporting or bearing plate 14.

At the left-hand end of the glue applying drum 21, the trunnion 20 of that end is extended to receive a gear 33 pinned thereto and which is in mesh with a corresponding gear 34 pinned to one of opposite trunnions 35 resting in open horizontal bearings 17, (see Figs. 2 and 4) of a wiper roller 36, driven at the same axial speed but of less surface speed than the distributing drum; the wiper roller being adjustable horizontally toward and away from the drum surface for changing the thickness of the glue film passing upwardly to the sheet material to be coated.

The above adjustment is accomplished by means or mechanism believed to be new and novel as a readily removable unit and embodies scraper heads or hubs 37, having bores 38, through which reduced portions 39, of the wiper roller 36, project into the said trunnions 35. These hubs 37, are formed each with a pair of backwardly directed fingers 40 and 41, and a forwardly projected lug 42 (see best Fig. 4) to which are bolted or otherwise secured as at 43, flat arms 44, which extend forwardly and rest on the top of the glue pan or receptacle 10. Of course these arms may be formed integral with the lugs 42 of the hubs 37 if desired.

The finger 40 of each head or hub 37, normally bears against the end of the drum 21, for scraping excess glue therefrom which drips back into the pan. The opposite fingers 41 of each hub bear against the inner sides of the end walls of the pan for holding the scraping fingers 40 in proper contact with the ends of said drum 21.

The arms 44, of the wiper and scraper unit, here generally designated in Fig. 4, by the nu-

meral 100, are each formed, as in Figs. 1 and 4, with a transverse recess 45 with its throat formed by oppositely flared walls 46, engaged by a pointed nose 47, projecting between them.

5 The nose is formed on a rock handle 48, (Fig. 1) pivoted on a bolt 49, and locked in a desired adjusted position by a winged nut 50, or otherwise; the arm 44, being backed-up by a safety spring 51, so as to permit a longitudinal outward movement of the arm 44, should the wiper roller be violently forced outwardly by a clot of hard foreign matter traveling upwardly with the glue on said drum.

15 It will be obvious that minute adjustments for film thicknesses may be made between the drum and wiper roll by rocking the handles and setting them, for the reason the trunnions of said roller are slidable in or along the horizontal bearings 17.

20 The drive gear 23, is meshed with the gear 23 to drive the drum 21, and is also in mesh with a gear 52, on one end of a sheet feeding roller 53. Resting on the feed roller in tensional contact is a pressure roller 54, mounted to rotate between the lower ends of drop arms 55 having flat seats 56, on which bear spring influenced arms 57, projecting from sleeves 58, mounted to rotate around vertical threaded pins 59, projecting from the plates 13 and 14 and passing through coiled springs 60, which are compressed by thumb nuts 61 on said threaded portion at the top of said pins. The lower ends of the springs rest on top of said sleeves 58, which do not bottom or rest on the supporting plates 13 and 14 as space must be allowed for pressure adjustments through said arms and presser roller as will be understood.

30 The upper or rear ends of the drop arms 55 are bored to receive a shaft 62 resting in the open bearings 18, and on this shaft are placed a series of sleeves 63 adapted for spacing a series of disks 64 either rotatable or fixed on said shaft. If said disks are loose on the shaft 62, they form anti-friction devices for easing the back pull of the coated paper when the finished sheet is pulled forwardly over said disks as shown in Fig. 3, of the drawings and by making these disks entirely circular the paper will not be torn or damaged when drawn from the machine at any angle.

40 Resting in the open bearings 19, at the rear of the machine, is another longitudinal shaft 65 upon which there are placed a number of spaced paper lifters 66, which act to pick up the coated sheet material from the drum and start the leading edge upwardly and it is then that the operator standing at the front of the machine, at the table plate 67, should reach backwardly and grasp said edge for guiding it where desired.

50 The lifters 66, comprise castings forked as at 68, to straddle the shaft 65 and the said castings have a seating rib 69, and a bore for receiving a clamp screw 70 for retaining an oppositely beveled blade to produce pickup points 71, which are reversible for wear and one point rests on the coating drum through gravity and these pickups may be removed at will for cleaning.

60 As shown in Figs. 4 and 7, the scraper head 37, is also formed with a scraper bar 40a, contacting the wiper roller extensions 39, for scraping back any excess of glue accumulating, to drop back into the glue pan as will be obvious.

70 Having thus described the invention what is claimed is:

1. In a coating machine, the combination of a rotary drum for collecting and distributing a

5 coating of adhesive; of a wiper roll operating in coaction with the drum for controlling the thickness of said adhesive; means, carried by the wiper roller for scraping the ends of said drum free of adhesive, means at one end of the drum for driving the same and means at the opposite end of the drum for driving said wiper roller at the same axial speed as the drum when in operation, and tensioned means for feeding the material to be coated to said drum.

10 2. In a coating machine, the combination with a frame including a glue containing pan and end supports, of a rotary glue collecting drum and a wiper roll coacting with said drum for proper distribution of said glue on sheet material means for driving the drum from one of its ends and means on the opposite end of said drum for driving said wiper roll at an equal axial speed, a scraper head on opposite ends of the wiper roller having parallel fingers, the inner of said fingers contacting the end faces of said drum the outer of said fingers contacting the walls of said glue pan; fixed arms on said heads having their ends resting on the edge of said glue pan and means engaging said arms for adjusting the distance between the drum and wiper roller and means for feeding sheet material to said drum.

25 3. A coating machine including a glue supply a rotary drum passing through said supply; a wiper roller coacting with said drum to limit the coating to be distributed; frames for supporting the drum and roller; scraper devices mounted on the ends of said roller and contacting the end faces of said drum, said scraper devices including fixed fingers projecting backwardly of said wiper shaft and said frames being provided with horizontal slot bearings for permitting the wiper roll and connected scrapers to be drawn forwardly and out of said frame as a unit.

40 4. A coating machine embodying a rotary drum and means for coating the surface thereof with a film of glue; a wiper roller coacting with the drum for regulating the adhesive coating on said drum, a feed roller for feeding sheets to said drum to be coated; a presser roller resting on the sheets and over the feed roller; a fixed shaft; arms pivoted on said shaft for supporting said presser roller flat seats on said arms and spring depressed arms resting on said seats for maintaining a pressure on said sheets, and power means for driving the drum wiper roller and feed roller.

50 5. In a coating machine, a frame comprising a glue pan and end plates having open bearings a rotary drum, a wiper roller; means for driving the drum through said pan for collecting an adhesive supply, scraper heads on the ends of the wiper roller, pairs of fingers on said head contacting the end faces of said drum and the walls of said pan; arms extending from said heads and provided with recesses said recesses being flared at the edge of said arms; rockable projections extending into said recesses for adjusting the distance between the wiper roller and said drum means for locking said arms; means for feeding sheet material to the drum and means for driving the drum and wiper roll.

60 6. In a coating machine, the combination of a rotary drum and a pan for supplying glue thereto; scrapers arranged to cooperate with the end faces of said drum and for contacting the inner walls of said pan, comprising spaced fingers and integral heads; means coacting with said drum for wiping excess glue from said drum and for supporting said heads and means for adjust-

ing the position of the heads and wiping means.

7. In a coating machine, the combination with a rotary glue distributing drum and a glue filled pan or frame through which the drum rotates; means for feeding sheet material to the drum including a power driven roller and a presser roller; a shaft fixed in a bearing on said pan; a series of circular disks carried by the shaft and spaced apart to form a minimum area of supporting surfaces for the backs of sheets pulled forwardly over the machine when coated; arms swingable on said shaft for supporting said presser roller, flat seats on said arms; vertical posts fixed to the pan frame; sleeves loose on the posts; springs on said posts and thumb nuts for depressing the springs onto said sleeves and fingers projecting from the sleeves and resting on said seats for creating a feeding tension by said presser roller.

8. In a coating machine, the combination of a rotary drum and means for supplying its face with glue, means for rotating the drum, feed and tension rollers for advancing a sheet of material to the surface of said drum; a wiper roller supported close up to the drum; means on said wiper roller for contacting the end faces of the drum said means comprising heads having scraping fingers for the ends of said drum; adjusting arms connected with the heads, said arms having recesses engaged by rock-lugs; and safety springs arranged opposite the adjusting head for permitting the arms to move longitudinally and prevent breakage should a large foreign body get between the drum and wiper roller.

9. In a coating machine, the combination with a rotary glue applying drum and means for supplying glue to the face thereof including a pan through which said drum rotates, plates on the ends of the pan, horizontal bearings at the upper edge of said pan; a wiper roller coacting with said drum and having trunnions projecting through said horizontal bearings; scrapers carried at the ends of the wiper shaft; arms projecting from said scrapers, means for engaging said arms for adjusting the wiper roller and for removing or sliding the roller and scraper from said bearing.

10. In a coating machine, the combination of a

rotary drum and means for supplying an adhesive to its surface, including a glue filled pan, bearing plates on the ends thereof; a stud bolt threaded into the right hand bearing plate; a gear and a connected pulley mounted to freely rotate on said bolt; a feed roller, a gear at one end thereof and in mesh with the gear on the stud bolt; a large gear on the right end trunnion of said drum and also in mesh with said gear on the said stud bolt; a wiper roller coacting with the drum for controlling the thickness of glue film thereon; equal gears pinned to the left hand trunnion of said drum and to the corresponding end of the shaft of said wiper roller to impart like axial speed; tensioned means coacting with said feed roller for feeding sheet material to the surface of said drum and power means for driving said pulley.

11. In a coating machine of the class described, the combination with a distributing drum and means for introducing a coating of glue to the face thereof; of a wiper roller coacting with the drum to produce an appropriate film of glue thereon; means for feeding a sheet of material to be coated by the film on said drum; means for driving the drum and wiper roller; heads on the ends of the said wiper roller, said heads being formed with rigid scraper fingers for engaging the ends of said drum and integral cross bars on said heads for scraping the surfaces of the ends of said wiper roller for removing accumulated glue on the ends of the drum and the ends of the wiper roller, where each passes through said heads.

12. In a coating machine, the combination of a rotary glue applying drum and means for supplying a coating of glue to the face thereof; a wiper roller coacting with the drum for adjusting the thickness of the glue coat; heads on the ends of the wiper roller; said heads having means for scraping the ends of the drum and means for simultaneously scraping the sides of the wiper roller for removing excess glue accumulations in the operation of the machine; means for feeding a sheet to be coated to the drum and means for driving the said drum and wiper roller.

AUGUST M. BECKER.