



HU000033337T2

(19) **HU**(11) Lajstromszám: **E 033 337**(13) **T2****MAGYARORSZÁG**
Szellemi Tulajdon Nemzeti Hivatala**EURÓPAI SZABADALOM**
SZÖVEGÉNEK FORDÍTÁSA

- (21) Magyar ügyszám: **E 09 717505** (51) Int. Cl.: **H04B 7/04** (2006.01)
(22) A bejelentés napja: **2009. 03. 05.** **H04W 72/00** (2006.01)
H04L 1/18 (2006.01)
(96) Az európai bejelentés bejelentési száma: **H04L 25/03** (2006.01)
EP 20090717505 **H04L 1/00** (2006.01)
(97) Az európai bejelentés közzétételi adatai: **H04L 1/06** (2006.01)
EP 2263328 A2 **2009. 09. 11.**
(97) Az európai szabadalom megadásának meghirdetési adatai: (86) A nemzetközi (PCT) bejelentési szám: **PCT/KR 09/001106**
EP 2263328 B1 **2016. 12. 07.** (87) A nemzetközi közzétételi szám: **WO 09110759**

(30) Elsőbbségi adatok: 34145 P 2008. 03. 05. US 20090017741 2009. 03. 02. KR	(73) Jogosult(ak): LG Electronics Inc., Seoul 150-721 (KR)
(72) Feltaláló(k): CHUNG, Jae Hoon, Anyang-siGyeonggi-do 431-749 (KR) KO, Hyun Soo, Anyang-siGyeonggi-do 431-749 (KR) HAN, Seung Hee, Anyang-siGyeonggi-do 431-749 (KR) LEE, Moon Il, Anyang-siGyeonggi-do 431-749 (KR)	(74) Képviselő: SBGK Szabadalmi Ügyvivői Iroda, Budapest

(54) **Adatátviteli eljárás többantennás rendszerben**

Az európai szabadalom ellen, megadásának az Európai Szabadalmi Közlönyben való meghirdetésétől számított kilenc hónapon belül, felszólalást lehet benyújtani az Európai Szabadalmi Hivatalnál. (Európai Szabadalmi Egyezmény 99. cikk(1))

A fordítást a szabadalmas az 1995. évi XXXIII. törvény 84/H. §-a szerint nyújtotta be. A fordítás tartalmi helyességét a Szellemi Tulajdon Nemzeti Hivatala nem vizsgálta.



(11) **EP 2 263 328 B1**

(12) **EUROPEAN PATENT SPECIFICATION**

(45) Date of publication and mention of the grant of the patent:
07.12.2016 Bulletin 2016/49

(21) Application number: **09717505.3**

(22) Date of filing: **05.03.2009**

(51) Int Cl.:
H04B 7/04 (2006.01) **H04W 72/00** (2009.01)
H04L 1/18 (2006.01) **H04L 1/06** (2006.01)
H04L 1/00 (2006.01) **H04L 25/03** (2006.01)

(86) International application number:
PCT/KR2009/001106

(87) International publication number:
WO 2009/110759 (11.09.2009 Gazette 2009/37)

(54) **METHOD OF DATA TRANSMISSION IN MULTIPLE ANTENNA SYSTEM**

VERFAHREN ZUR DATENÜBERTRAGUNG IN EINEM MEHRANTENNENSYSTEM

PROCÉDÉ DE TRANSMISSION DE DONNÉES DANS UN SYSTÈME À ANTENNES MULTIPLES

(84) Designated Contracting States:
AT BE BG CH CY CZ DE DK EE ES FI FR GB GR HR HU IE IS IT LI LT LU LV MC MK MT NL NO PL PT RO SE SI SK TR

(30) Priority: **05.03.2008 US 34145 P**
02.03.2009 KR 20090017741

(43) Date of publication of application:
22.12.2010 Bulletin 2010/51

(60) Divisional application:
16193080.5

(73) Proprietor: **LG Electronics Inc.**
Seoul 150-721 (KR)

(72) Inventors:
• **CHUNG, Jae Hoon**
Anyang-si
Gyeonggi-do 431-749 (KR)
• **KO, Hyun Soo**
Anyang-si
Gyeonggi-do 431-749 (KR)
• **HAN, Seung Hee**
Anyang-si
Gyeonggi-do 431-749 (KR)
• **LEE, Moon Il**
Anyang-si
Gyeonggi-do 431-749 (KR)

(74) Representative: **Cabinet Plasseraud**
66, rue de la Chaussée d'Antin
75440 Paris Cedex 09 (FR)

(56) References cited:
KR-A- 20010 076 252 KR-A- 20050 053 787
KR-A- 20070 089 748

- **SAMSUNG: "Considerations on codewords to layers mapping for downlink MIMO", 3GPP DRAFT; R1-070130, 3RD GENERATION PARTNERSHIP PROJECT (3GPP), MOBILE COMPETENCE CENTRE ; 650, ROUTE DES LUCIOLES ; F-06921 SOPHIA-ANTIPOLIS CEDEX ; FRANCE, vol. RAN WG1, no. Sorrento, Italy; 20070110, 10 January 2007 (2007-01-10), XP050104177, [retrieved on 2007-01-10]**
- **TEXAS INSTRUMENTS: "Codeword-to-Layer Mapping for E-UTRA MIMO", 3GPP DRAFT; R1-071199 TI MIMO MCW UPDATE, 3RD GENERATION PARTNERSHIP PROJECT (3GPP), MOBILE COMPETENCE CENTRE ; 650, ROUTE DES LUCIOLES ; F-06921 SOPHIA-ANTIPOLIS CEDEX ; FRANCE, vol. RAN WG1, no. St. Louis, USA; 20070218, 18 February 2007 (2007-02-18), XP050105171, [retrieved on 2007-02-18]**
- **LG ELECTRONICS: "Codeword to layer mapping for SU-MIMO", 3GPP DRAFT; R1-070235, 3RD GENERATION PARTNERSHIP PROJECT (3GPP), MOBILE COMPETENCE CENTRE ; 650, ROUTE DES LUCIOLES ; F-06921 SOPHIA-ANTIPOLIS CEDEX ; FRANCE, vol. RAN WG1, no. Sorrento, Italy; 20070110, 10 January 2007 (2007-01-10), XP050104274, [retrieved on 2007-01-10]**

Note: Within nine months of the publication of the mention of the grant of the European patent in the European Patent Bulletin, any person may give notice to the European Patent Office of opposition to that patent, in accordance with the Implementing Regulations. Notice of opposition shall not be deemed to have been filed until the opposition fee has been paid. (Art. 99(1) European Patent Convention).

EP 2 263 328 B1

- ERICSSON: "Extending Codeword to Layer Mapping for Efficient Support of Retransmissions", 3GPP DRAFT; R1-080877, 3RD GENERATION PARTNERSHIP PROJECT (3GPP), MOBILE COMPETENCE CENTRE ; 650, ROUTE DES LUCIOLES ; F-06921 SOPHIA-ANTIPOLIS CEDEX ; FRANCE, vol. RAN WG1, no. Sorrento, Italy; 20080206, 6 February 2008 (2008-02-06), XP050109353, [retrieved on 2008-02-06]

Description**Technical Field**

5 **[0001]** The present invention relates to a multiple antenna system, and more particularly, to a method of transmitting a codeword by mapping the codeword to a layer in the multiple antenna system.

Background Art

10 **[0002]** Wireless communication systems are widely spread all over the world to provide various types of communication services such as voice or data. In general, the wireless communication system is a multiple access system capable of supporting communication with multiple users by sharing available system resources (e.g., bandwidth, transmit (Tx) power, etc.). Examples of the multiple access system include a code division multiple access (CDMA) system, a frequency division multiple access (FDMA) system, a time division multiple access (TDMA) system, an orthogonal frequency division multiple access (OFDMA) system, a single carrier frequency division multiple access (SC-FDMA) system, etc.

15 **[0003]** The OFDMA is a multiple access scheme for allocating subcarriers having orthogonality to respective users. The OFDMA can reduce inter-symbol interference (ISI) and provide a high data rate by supporting characteristics robust to frequency selective fading of a channel. By allocating mutually independent subcarriers to the users, the OFDMA significantly decreases a probability that a specific subcarrier is in a deep fading state with respect to all users. Therefore, since subcarriers have a mutually independent characteristic between users, Tx power decrease and throughput improvement can be achieved by adaptively allocating the subcarriers to a user having a good channel condition.

20 **[0004]** To overcome performance deterioration caused by channel fading of wireless communication, many researches have been conducted on spatial diversity and/or spatial multiplexing using a multiple input multiple output (MIMO) system. The MIMO system is implemented so that a transmitter and a receiver have two or more antennas, thereby providing advantages such as a high data rate, reliability improvement, channel capacity increase, etc.

25 **[0005]** Multiple antennas are supported in Institute of electrical and electronics engineers (IEEE) 802.16 (WiMAX) and 3rd generation partnership project (3GPP) long term evolution (LTE) for which standardization has recently been conducted. As disclosed in 3GPP TS 36.211 V8.0.0 (2007-09) "Technical Specification Group Radio Access Network; Evolved Universal Terrestrial Radio Access (E-UTRA); Physical channels and modulation (Release 8)", the 3GPP LTE employs the OFDMA in downlink and employs the SC-FDMA in uplink.

30 **[0006]** According to the 3GPP TS 36.211 V8.0.0, the 3GPP LTE supports up to 4 antenna ports. The 3GPP Draft No. R1-070130, entitled "Considerations on codewords to layers mapping for downlink MIMO", describes schemes for mapping codewords to MIMO layers for downlink MIMO in a system supporting up to a maximum of 4 layers.

35 The 3GPP Draft No. R1-071199, entitled "Codeword-to-Layer Mapping for E-UTRA MIMO", describes codeword-to-layer mappings for rank-4 MIMO transmissions in a E-UTRA system.

The 3GPP Draft No. R1-070235, entitled "Codeword to layer mapping for SU-MIMO", describes codeword-to-layer mappings for Single User MIMO transmissions with a maximum number of codewords for downlink MIMO equal to 2, and a maximum number of layers equal to 4.

40 However, the number of antenna ports is expected to be greater than that in a next generation wireless communication system requiring a higher maximum data rate. Therefore, there is a need for a method of supporting 4 or more antenna ports in a multiple antenna system.

Disclosure of Invention**Technical Problem**

45 **[0007]** The present invention provides a method of transmitting a codeword in a multiple antenna system.

Technical Solution

50 **[0008]** To facilitate full understanding of the invention, this description includes examples and technical background information that do not fall in the scope of the claimed subject-matter. In an aspect, a method of data transmission in a multiple antenna system is provided as set forth in the appended claims.

[0009] In another aspect, a transmitter is provided as set forth in the appended claims.

55 **[0010]** In still another aspect, a method of receiving data in a multiple antenna system is provided as set forth in the appended claims.

[0011] In still another aspect, a receiver is provided as set forth in the appended claims.

Advantageous Effects

[0012] A multiple antenna system having 6 or 8 antenna ports can be implemented, and an improved data rate and quality of service (QoS) can be supported.

5

Brief Description of Drawings

[0013]

10 FIG. 1 shows a wireless communication system.
FIG. 2 is a block diagram showing a transmitter having multiple antennas according to an embodiment of the present invention.
FIG. 3 shows layer mapping according to a 1st embodiment of the present invention.
15 FIG. 4 shows extended mapping when layer mapping is performed according to a 1st embodiment of the present invention.
FIG. 5 shows layer mapping according to a 2nd embodiment of the present invention.
FIG. 6 shows extended mapping when layer mapping is performed according to a 2nd embodiment of the present invention.
20 FIG. 7 shows layer mapping according to a 3rd embodiment of the present invention.
FIG. 8 shows extended mapping when layer mapping is performed according to a 3rd embodiment of the present invention.
FIG. 9 shows layer mapping according to a 4th embodiment of the present invention.
FIG. 10 shows extended mapping when layer mapping is performed according to a 4th embodiment of the present invention.
25 FIG. 11 shows layer mapping according to a 5th embodiment of the present invention.
FIG. 12 shows extended mapping when layer mapping is performed according to a 5th embodiment of the present invention.
FIG. 13 shows layer mapping according to a 6th embodiment of the present invention.
FIG. 14 shows extended mapping when layer mapping is performed according to a 6th embodiment of the present invention.
30 FIG. 15 shows layer mapping according to a 7th embodiment of the present invention.
FIG. 16 shows extended mapping when layer mapping is performed according to a 7th embodiment of the present invention.
FIG. 17 shows layer mapping according to an 8th embodiment of the present invention.
35 FIG. 18 shows extended mapping when layer mapping is performed according to an 8th embodiment of the present invention.
FIG. 19 shows layer mapping according to a 9th embodiment of the present invention.
FIG. 20 shows extended mapping when layer mapping is performed according to a 9th embodiment of the present invention.
40 FIG. 21 shows layer mapping according to a 10th embodiment of the present invention.
FIG. 22 shows extended mapping when layer mapping is performed according to a 10th embodiment of the present invention.
FIG. 23 shows layer mapping according to an 11th embodiment of the present invention.
45 FIG. 24 shows extended mapping when layer mapping is performed according to an 11th embodiment of the present invention.
FIG. 25 shows layer mapping according to a 12th embodiment of the present invention.
FIG. 26 shows extended mapping in layer mapping according to a 12th embodiment of the present invention.
FIG. 27 shows layer mapping according to a 13th embodiment of the present invention.
50 FIG. 28 shows extended mapping when layer mapping is performed according to a 13th embodiment of the present invention.
FIG. 29 shows layer mapping according to a 14th embodiment of the present invention.
FIG. 30 shows extended mapping when layer mapping is performed according to a 14th embodiment of the present invention.
55 FIG. 31 shows layer mapping according to a 15th embodiment of the present invention.
FIG. 32 shows extended mapping when layer mapping is performed according to a 15th embodiment of the present invention.
FIG. 33 shows layer mapping according to a 16th embodiment of the present invention.
FIG. 34 shows extended mapping when layer mapping is performed according to a 16th embodiment of the present invention.

invention.

FIG. 35 is a flow diagram showing triggering from basic mapping to extended mapping by hybrid automatic repeat request (HARQ) retransmission.

FIG. 36 is a flowchart showing triggering from basic mapping to extended mapping.

FIG. 37 is a flowchart showing a method of data transmission according to an embodiment of the present invention.

FIG. 38 is a block diagram showing a transmitter according to an embodiment of the present invention.

FIG. 39 is a flowchart showing a method of communication according to an embodiment of the present invention.

Mode for the Invention

[0014] The technique, method and apparatus described below can be used in various wireless access technologies such as code division multiple access (CDMA), frequency division multiple access (FDMA), time division multiple access (TDMA), orthogonal frequency division multiple access (OFDMA), single carrier frequency division multiple access (SC-FDMA), etc. The wireless access technologies can be implemented with various wireless communication standard systems. 3rd generation partnership project (3GPP) long term evolution (LTE) is a part of an evolved-universal mobile telecommunications system (E-UMTS). The 3GPP LTE employs the OFDMA in downlink and employs the SC-FDMA in uplink. LTE-advance (LTE-A) is an evolution of the LTE.

[0015] For clarity, the following description will focus on the 3GPP LTE/LTE-A. However, technical features of the present invention are not limited thereto.

[0016] The term "or" is intended to mean an inclusive "or" rather than an exclusive "or". Unless specified otherwise, or clear from the context, a phrase "X employs A or B" is intended to mean any of the natural inclusive permutations. That is, the phrase "X employs A or B" is satisfied by any of the following instances: X employs A; X employs B; or X employs A and B. In addition, the articles "a" and "an" as used in this application and the appended claims is generally construed to mean "one or more" unless specified otherwise or clear from the context to be directed to a singular form.

[0017] The technique, method and apparatus described below applies to a multiple antenna system or a multiple input multiple output (MIMO) system using multiple transmit (Tx) antennas and at least one receive (Rx) antenna. The technology described below may apply to various MIMO schemes. The MIMO scheme includes spatial diversity in which the same stream is transmitted to multiple layers and spatial multiplexing in which multiple streams are transmitted to multiple layers. When the multiple streams are transmitted to a single user in the spatial multiplexing, it is called single user-MIMO (SU-MIMO) or spatial division multiple access (SDMA). When the multiple streams are transmitted to multiple users in the spatial multiplexing, it is called multi user-MIMO (MU-MIMO). According to whether feedback information reported from each user is used or not, the spatial diversity and the spatial multiplexing can be classified into an open-loop scheme and a closed-loop scheme.

[0018] FIG. 1 shows a wireless communication system. Referring to FIG. 1, a wireless communication system 10 includes at least one base station (BS) 11. The BSs 11 provide communication services to specific geographical regions (generally referred to as cells) 15a, 15b, and 15c. The cell can be divided into a plurality of regions (referred to as sectors). A user equipment (UE) 12 may be fixed or mobile, and may be referred to as another terminology, such as a mobile station (MS), a user terminal (UT), a subscriber station (SS), a wireless device, a personal digital assistant (PDA), a wireless modem, a handheld device, etc. The BS 11 is generally a fixed station that communicates with the UE 12 and may be referred to as another terminology, such as an evolved node-B (eNB), a base transceiver system (BTS), an access point, etc.

[0019] Hereinafter, a downlink denotes a communication link from the BS to the UE, and an uplink denotes a communication link from the UE to the BS. In downlink, a transmitter may be a part of the BS, and a receiver may be a part of the UE. In uplink, the transmitter may be a part of the UE, and the receiver may be a part of the BS.

[0020] FIG. 2 is a block diagram showing a transmitter having multiple antennas according to an embodiment of the present invention.

[0021] Referring to FIG. 2, a transmitter 100 includes channel encoders 110-1 and 110-2, mappers 120-1 and 120-2, a layer mapping unit 140, a precoder 150, and signal generators 160-1, ..., 160-Nt. Nt denotes the number of antenna ports. The channel encoders 110-1 and 110-2 encode input information bits according to a predetermined coding scheme to generate codewords. The first channel encoder 110-1 generates a first codeword CW1, and the second channel encoder 110-2 generates a second codeword CW2.

[0022] The mappers 120-1 and 120-2 modulate the respective codewords according to a modulation scheme and then map the modulated codewords to modulation symbols having a demodulation value. There is no restriction on the modulation scheme. The modulation scheme may be m-phase shift keying (m-PSK) or m-quadrature amplitude modulation (m-QAM). For example, the m-PSK may be binary-PSK (BPSK), quadrature-PSK (QPSK), or 8-PSK. The m-QAM may be 16-QAM, 64-QAM, or 256-QAM. The first mapper 120-1 generates modulation symbols for the first codeword CW1. The second mapper 120-2 generates modulation symbols for the second codeword CW2.

[0023] Although the transmitter 100 includes the two channel encoders 110-1 and 110-2 and the two mappers 120-1

and 120-2 to process the two codewords, the number of channel encoders and the number of mappers included in the transmitter 100 are not limited thereto. The transmitter 100 may include at least one channel encoder and at least one mapper to process at least one codeword.

[0024] The layer mapping unit 140 maps modulation symbols of the input codewords CW1 and CW2 to each layer according to the number of layers. The layer may be an information path input to the precoder 150. The layer corresponds to a rank value. The layer mapping unit 140 may determine the number of layers (i.e., rank), and thereafter map modulation symbols of each codeword.

[0025] The precoder 150 processes a mapping symbol which is mapped to each layer by using a MIMO scheme depending on a plurality of antenna ports 190-1, ..., 190-Nt and outputs antenna specific symbols. The signal generators 160-1, ..., 160-Nt convert the antenna specific symbols into Tx signals. The Tx signals are transmitted through the respective antenna ports 190-1, ..., 190-Nt. The signal generators 160-1, ..., 160-Nt may perform orthogonal frequency division multiplexing (OFDM) modulation or may generate a transmit signal by using an SC-FDMA modulation scheme or other schemes well-known to those skilled in the art.

[0026] The transmitter 100 can support hybrid automatic repeat request (HARQ). In a retransmission process for the HARQ, the same layer mapping as initial transmission may be performed, or layer mapping for retransmission may be performed. Further, the transmitter 100 can support rank adaptation in which a rank is changed according to a channel condition.

[0027] According to the section 6.3 of 3GPP TS 36.211 V8.0.0 (2007-09), in the 3GPP LTE, modulation symbols $d^{(q)}(0), \dots, d^{(q)}(M_{\text{symb}}^{(q)}-1)$ for a codeword q are mapped to a layer $x(i)=[x^{(0)}(i) \dots x^{(v-1)}(i)]^T$ ($i=0,1,\dots, M_{\text{symb}}^{\text{layer}}-1$). Herein, $M_{\text{symb}}^{(q)}$ denotes the number of modulation symbols for the codeword q , v denotes the number of layers, and $M_{\text{symb}}^{\text{layer}}$ denotes the number of modulation symbols for each layer. Table 1 shows codeword-to-layer mapping for spatial multiplexing.

[0028] Table 1

[Table 1]

Number of layers	Number of code words	Codeword-to-layer mapping $i = 0, 1, \dots, M_{\text{symb}}^{\text{layer}} - 1$
1	1	$x^{(0)}(i) = d^{(0)}(i)$ $M_{\text{symb}}^{\text{layer}} = M_{\text{symb}}^{(0)}$
2	2	$x^{(0)}(i) = d^{(0)}(i)$ $x^{(1)}(i) = d^{(1)}(i)$ $M_{\text{symb}}^{\text{layer}} = M_{\text{symb}}^{(0)} = M_{\text{symb}}^{(1)}$
3	2	$x^{(0)}(i) = d^{(0)}(i)$ $x^{(1)}(i) = d^{(1)}(2i)$ $x^{(2)}(i) = d^{(1)}(2i + 1)$ $M_{\text{symb}}^{\text{layer}} = M_{\text{symb}}^{(0)} = M_{\text{symb}}^{(1)} / 2$
4	2	$x^{(0)}(i) = d^{(0)}(2i)$ $x^{(1)}(i) = d^{(0)}(2i + 1)$ $x^{(2)}(i) = d^{(1)}(2i)$ $x^{(3)}(i) = d^{(1)}(2i + 1)$ $M_{\text{symb}}^{\text{layer}} = M_{\text{symb}}^{(0)} / 2 = M_{\text{symb}}^{(1)} / 2$

[0029] According to Table 1, multi-codeword transmission is supported for up to 4 layers, i.e., 4 antenna ports. However, multi-codeword transmission for 6 or 8 antenna ports is not provided.

[0030] A method described below relates to codeword-to-layer mapping in MIMO transmission based on at least one codeword for a single user when the number of antenna ports is 6 or 8. MIMO transmission for up to two codewords is designed by considering complexity and feedback overhead of a system. Backward compatibility with the conventional 3GPP LTE is also considered.

[0031] Parameters to be used hereinafter are defined as follows.

$M_{\text{symb}}^{(q)}$: the number of modulation symbols for a codeword q

$d^{(q)}(0), \dots, d^{(q)}(M_{\text{symb}}^{(q)}-1)$: modulation symbols for the codeword q

v : the number of layers

$M_{\text{symb}}^{\text{layer}}$: the number of modulation symbols for each layer

$x(i)=[x^{(0)}(i) \dots x^{(v-1)}(i)]^T, i=0,1,\dots, M_{\text{symb}}^{\text{layer}}-1$: mapping symbols mapped to layers

[0032] In the drawings described below, 'CWn' denotes modulation symbols for a codeword n, and 'S/P' denotes a serial-to-parallel converter. There is no restriction on MIMO precoding performed in a precoder. Well-known schemes (e.g., cyclic delay diversity (CDD), space frequency block code (SFBC), space time block code (STBC), and a combination of them) may be used in the MIMO precoding.

[0033] FIG. 3 shows layer mapping according to a 1st embodiment of the present invention. Herein, 6 antenna ports are used for layer mapping at ranks 1 to 6. This can be shown by Table 2.

[0034] Table 2

[Table 2]

Number of layers	Number of codewords	Codeword-to-layer mapping, $i = 0, 1, \dots, M_{\text{sy mb}}^{\text{layer}} - 1$
1	1	$x^{(0)}(i) = d^{(0)}(i)$ $M_{\text{sy mb}}^{\text{layer}} = M_{\text{sy mb}}^{(0)}$
2	2	$x^{(0)}(i) = d^{(0)}(i)$ $x^{(1)}(i) = d^{(1)}(i)$ $M_{\text{sy mb}}^{\text{layer}} = M_{\text{sy mb}}^{(0)} = M_{\text{sy mb}}^{(1)}$
3	2	$x^{(0)}(i) = d^{(0)}(i)$ $x^{(1)}(i) = d^{(1)}(2i)$ $x^{(1)}(i) = d^{(1)}(2i + 1)$ $M_{\text{sy mb}}^{\text{layer}} = M_{\text{sy mb}}^{(0)} = M_{\text{sy mb}}^{(1)} / 2$
4	2	$x^{(0)}(i) = d^{(0)}(2i)$ $x^{(1)}(i) = d^{(0)}(2i + 1)$ $x^{(2)}(i) = d^{(1)}(2i)$ $x^{(3)}(i) = d^{(1)}(2i + 1)$ $M_{\text{sy mb}}^{\text{layer}} = M_{\text{sy mb}}^{(0)} / 2 = M_{\text{sy mb}}^{(1)} / 2$
5	2	$x^{(0)}(i) = d^{(0)}(2i)$ $x^{(1)}(i) = d^{(0)}(2i + 1)$ $x^{(2)}(i) = d^{(1)}(3i)$ $x^{(3)}(i) = d^{(1)}(3i + 1)$ $x^{(4)}(i) = d^{(1)}(3i + 2)$ $M_{\text{sy mb}}^{\text{layer}} = M_{\text{sy mb}}^{(0)} / 2 = M_{\text{sy mb}}^{(1)} / 3$
6	2	$x^{(0)}(i) = d^{(0)}(3i)$ $x^{(1)}(i) = d^{(0)}(3i + 1)$ $x^{(2)}(i) = d^{(0)}(3i + 2)$ $x^{(3)}(i) = d^{(1)}(3i)$ $x^{(4)}(i) = d^{(1)}(3i + 1)$ $x^{(5)}(i) = d^{(1)}(3i + 2)$ $M_{\text{sy mb}}^{\text{layer}} = M_{\text{sy mb}}^{(0)} / 3 = M_{\text{sy mb}}^{(1)} / 3$

[0035] At the rank 3, a first codeword CW1 may be mapped to a first layer, and a second codeword CW2 may be arranged in a second layer and a third layer. Thus, a gain can be obtained when a receiver performs successive interference cancellation (SIC).

[0036] At the rank 4 or higher, inter-layer interference may be increased in proportion to the number of layers to be mapped for each codeword. According to the aforementioned layer mapping, codeword decoding performance can be optimized by equalizing codeword symbols to be mapped to each layer as much as possible. When the receiver performs the SIC, interference cancellation between layers mapped to the second codeword CW2 may be supported according to a channel decoding result of the first codeword CW1 or according to a soft value of a symbol level.

[0037] FIG. 4 shows extended mapping when layer mapping is performed according to the last embodiment of the present invention. This can be shown by Table 3.

[0038] Table 3

[Table 3]

Number of layers	Number of codewords	Codeword-to-layer mapping, $i = 0, 1, \dots, M_{\text{symp}}^{\text{layer}} - 1$
1	1	$x^{(0)}(i) = d^{(1)}(i)$ $M_{\text{symp}}^{\text{layer}} = M_{\text{symp}}^{(1)}$
2	1	$x^{(0)}(i) = d^{(n)}(2i)$ $x^{(1)}(i) = d^{(n)}(2i + 1)$ $M_{\text{symp}}^{\text{layer}} = M_{\text{symp}}^{(n)} / 2, \quad n = 1 \text{ or } 2$
3	1	$x^{(0)}(i) = d^{(n)}(3i)$ $x^{(1)}(i) = d^{(n)}(3i + 1)$ $x^{(2)}(i) = d^{(n)}(3i + 2)$ $M_{\text{symp}}^{\text{layer}} = M_{\text{symp}}^{(n)} / 3, \quad n = 1 \text{ or } 2$

[0039] The extended mapping may be used as layer mapping for HARQ resources. When transmission of a first codeword is successful and transmission of a second codeword fails in initial transmission, the extended mapping is layer mapping for the failed codeword (i.e., the second codeword). Alternatively, the extended mapping may be used as layer mapping for supporting rank overriding.

[0040] FIG. 5 shows layer mapping according to a 2nd embodiment of the present invention. Herein, 6 antenna ports are used for layer mapping at ranks 1 to 6. In single codeword transmission at the rank 2 or lower, transmission performance can be improved by increasing a channel coding gain of a codeword. This can be shown by Table 4.

[0041] Table 4

[Table 4]

Number of layers	Number of codewords	Codeword-to-layer mapping, $i = 0, 1, \dots, M_{\text{symp}}^{\text{layer}} - 1$
1	1	$x^{(0)}(i) = d^{(0)}(i)$ $M_{\text{symp}}^{\text{layer}} = M_{\text{symp}}^{(0)}$
2	1	$x^{(0)}(i) = d^{(0)}(2i)$ $x^{(1)}(i) = d^{(0)}(2i + 1)$ $M_{\text{symp}}^{\text{layer}} = M_{\text{symp}}^{(0)} / 2$
3	2	$x^{(0)}(i) = d^{(0)}(i)$ $x^{(1)}(i) = d^{(1)}(2i)$ $x^{(2)}(i) = d^{(1)}(2i + 1)$ $M_{\text{symp}}^{\text{layer}} = M_{\text{symp}}^{(0)} = M_{\text{symp}}^{(1)} / 2$
4	2	$x^{(0)}(i) = d^{(0)}(2i)$ $x^{(1)}(i) = d^{(0)}(2i + 1)$ $x^{(2)}(i) = d^{(1)}(2i)$ $x^{(3)}(i) = d^{(1)}(2i + 1)$ $M_{\text{symp}}^{\text{layer}} = M_{\text{symp}}^{(0)} / 2 = M_{\text{symp}}^{(1)} / 2$
5	2	$x^{(0)}(i) = d^{(0)}(2i)$ $x^{(1)}(i) = d^{(0)}(2i + 1)$ $x^{(2)}(i) = d^{(1)}(3i)$ $x^{(3)}(i) = d^{(1)}(3i + 1)$ $x^{(4)}(i) = d^{(1)}(3i + 2)$ $M_{\text{symp}}^{\text{layer}} = M_{\text{symp}}^{(0)} / 2 = M_{\text{symp}}^{(1)} / 3$
6	2	$x^{(0)}(i) = d^{(0)}(3i)$ $x^{(1)}(i) = d^{(0)}(3i + 1)$ $x^{(2)}(i) = d^{(0)}(3i + 2)$ $x^{(3)}(i) = d^{(1)}(3i)$ $x^{(4)}(i) = d^{(1)}(3i + 1)$ $x^{(5)}(i) = d^{(1)}(3i + 2)$ $M_{\text{symp}}^{\text{layer}} = M_{\text{symp}}^{(0)} / 3 = M_{\text{symp}}^{(1)} / 3$

[0042] FIG. 6 shows extended mapping when layer mapping is performed according to the 2nd embodiment of the

present invention. The extended mapping is used to support HARQ retransmission or rank overriding, and this can be shown by Table 5.

[0043] Table 5

5

[Table 5]

10

15

Number of layers	Number of codewords	Codeword-to-layer mapping, $i = 0, 1, \dots, M_{\text{symb}}^{\text{layer}} - 1$
2	1	$x^{(0)}(i) = d^{(1)}(2i)$ $x^{(1)}(i) = d^{(1)}(2i + 1)$ $M_{\text{symb}}^{\text{layer}} = M_{\text{symb}}^{(1)} / 2$
3	1	$x^{(0)}(i) = d^{(n)}(3i)$ $x^{(1)}(i) = d^{(n)}(3i + 1)$ $x^{(2)}(i) = d^{(n)}(3i + 2)$ $M_{\text{symb}}^{\text{layer}} = M_{\text{symb}}^{(n)} / 3, \quad n = 1 \text{ or } 2$

[0044] FIG. 7 shows layer mapping according to a 3rd embodiment of the present invention. Herein, 6 antenna ports are used for layer mapping at ranks 1 to 6. In single codeword transmission at the rank 3 or lower, transmission performance can be improved by increasing a channel coding gain of a codeword. This can be shown by Table 6.

20

[0045] Table 6

[Table 6]

25

30

35

40

45

50

Number of layers	Number of codewords	Codeword-to-layer mapping, $i = 0, 1, \dots, M_{\text{symb}}^{\text{layer}} - 1$
1	1	$x^{(0)}(i) = d^{(0)}(i)$ $M_{\text{symb}}^{\text{layer}} = M_{\text{symb}}^{(0)}$
2	1	$x^{(0)}(i) = d^{(0)}(2i)$ $x^{(1)}(i) = d^{(0)}(2i + 1)$ $M_{\text{symb}}^{\text{layer}} = M_{\text{symb}}^{(0)} / 2$
3	1	$x^{(0)}(i) = d^{(0)}(3i)$ $x^{(1)}(i) = d^{(0)}(3i + 1)$ $x^{(2)}(i) = d^{(0)}(3i + 2)$ $M_{\text{symb}}^{\text{layer}} = M_{\text{symb}}^{(0)} / 3$
4	2	$x^{(0)}(i) = d^{(0)}(2i)$ $x^{(1)}(i) = d^{(0)}(2i + 1)$ $x^{(2)}(i) = d^{(1)}(2i)$ $x^{(3)}(i) = d^{(1)}(2i + 1)$ $M_{\text{symb}}^{\text{layer}} = M_{\text{symb}}^{(0)} / 2 = M_{\text{symb}}^{(1)} / 2$
5	2	$x^{(0)}(i) = d^{(0)}(2i)$ $x^{(1)}(i) = d^{(0)}(2i + 1)$ $x^{(2)}(i) = d^{(1)}(3i)$ $x^{(3)}(i) = d^{(1)}(3i + 1)$ $x^{(4)}(i) = d^{(1)}(3i + 2)$ $M_{\text{symb}}^{\text{layer}} = M_{\text{symb}}^{(0)} / 2 = M_{\text{symb}}^{(1)} / 3$
6	2	$x^{(0)}(i) = d^{(0)}(3i)$ $x^{(1)}(i) = d^{(0)}(3i + 1)$ $x^{(2)}(i) = d^{(0)}(3i + 2)$ $x^{(3)}(i) = d^{(1)}(3i)$ $x^{(4)}(i) = d^{(1)}(3i + 1)$ $x^{(5)}(i) = d^{(1)}(3i + 2)$ $M_{\text{symb}}^{\text{layer}} = M_{\text{symb}}^{(0)} / 3 = M_{\text{symb}}^{(1)} / 3$

[0046] FIG. 8 shows extended mapping when layer mapping is performed according to the 3rd embodiment of the present invention. The extended mapping is used to support HARQ retransmission or rank overriding, and this can be shown by Table 7.

55

[0047] Table 7

[Table 7]

Number of layers	Number of codewords	Codeword-to-layer mapping, $i = 0, 1, \dots, M_{\text{symp}}^{\text{layer}} - 1$
2	1	$x^{(0)}(i) = d^{(1)}(2i)$ $x^{(1)}(i) = d^{(1)}(2i + 1)$ $M_{\text{symp}}^{\text{layer}} = M_{\text{symp}}^{(1)} / 2$
3	1	$x^{(0)}(i) = d^{(1)}(3i)$ $x^{(1)}(i) = d^{(1)}(3i + 1)$ $x^{(2)}(i) = d^{(1)}(3i + 2)$ $M_{\text{symp}}^{\text{layer}} = M_{\text{symp}}^{(1)} / 3$

[0048] FIG. 9 shows layer mapping according to a 4th embodiment of the present invention. Herein, 6 antenna ports are used for layer mapping at ranks 1 to 6. In single codeword transmission at the rank 3 or lower, a change in an aspect of mapping each codeword to layers at different ranks is minimized. In transmission using active rank adaptation, disparity between a modulation and coding scheme (MCS) used in transmission and a channel quality indicator (CQI) reported by the UE depending on the rank change can be minimized. This can be shown by Table 8.

[0049] Table 8

[Table 8]

Number of layers	Number of codewords	Codeword-to-layer mapping, $i = 0, 1, \dots, M_{\text{symp}}^{\text{layer}} - 1$
1	1	$x^{(0)}(i) = d^{(0)}(i)$ $M_{\text{symp}}^{\text{layer}} = M_{\text{symp}}^{(0)}$
2	1	$x^{(1)}(i) = d^{(0)}(2i)$ $x^{(1)}(i) = d^{(0)}(2i + 1)$ $M_{\text{symp}}^{\text{layer}} = M_{\text{symp}}^{(0)} / 2$
3	1	$x^{(0)}(i) = d^{(0)}(3i)$ $x^{(1)}(i) = d^{(0)}(3i + 1)$ $x^{(2)}(i) = d^{(0)}(3i + 2)$ $M_{\text{symp}}^{\text{layer}} = M_{\text{symp}}^{(0)} / 3$
4	2	$x^{(0)}(i) = d^{(0)}(3i)$ $x^{(1)}(i) = d^{(0)}(3i + 1)$ $x^{(2)}(i) = d^{(0)}(3i + 2)$ $x^{(3)}(i) = d^{(1)}(i)$ $M_{\text{symp}}^{\text{layer}} = M_{\text{symp}}^{(0)} / 3 = M_{\text{symp}}^{(1)}$
5	2	$x^{(0)}(i) = d^{(0)}(2i)$ $x^{(1)}(i) = d^{(0)}(2i + 1)$ $x^{(2)}(i) = d^{(1)}(3i)$ $x^{(3)}(i) = d^{(1)}(3i + 1)$ $x^{(4)}(i) = d^{(1)}(3i + 2)$ $M_{\text{symp}}^{\text{layer}} = M_{\text{symp}}^{(0)} / 2 = M_{\text{symp}}^{(1)} / 3$
6	2	$x^{(0)}(i) = d^{(0)}(3i)$ $x^{(1)}(i) = d^{(0)}(3i + 1)$ $x^{(2)}(i) = d^{(0)}(3i + 2)$ $x^{(3)}(i) = d^{(1)}(3i)$ $x^{(4)}(i) = d^{(1)}(3i + 1)$ $x^{(5)}(i) = d^{(1)}(3i + 2)$ $M_{\text{symp}}^{\text{layer}} = M_{\text{symp}}^{(0)} / 3 = M_{\text{symp}}^{(1)} / 3$

[0050] FIG. 10 shows extended mapping when layer mapping is performed according to the 4th embodiment of the present invention. The extended mapping is used to support HARQ retransmission or rank overriding, and this can be shown by Table 9.

[0051] Table 9

[Table 9]

Number of layers	Number of codewords	Codeword-to-layer mapping, $i = 0, 1, \dots, M_{\text{symp}}^{\text{layer}} - 1$
1	1	$x^{(0)}(i) = d^{(1)}(i)$ $M_{\text{symp}}^{\text{layer}} = M_{\text{symp}}^{(1)}$
2	1	$x^{(0)}(i) = d^{(1)}(2i)$ $x^{(1)}(i) = d^{(1)}(2i + 1)$ $M_{\text{symp}}^{\text{layer}} = M_{\text{symp}}^{(1)} / 2$
3	1	$x^{(0)}(i) = d^{(1)}(3i)$ $x^{(1)}(i) = d^{(1)}(3i + 1)$ $x^{(2)}(i) = d^{(1)}(3i + 2)$ $M_{\text{symp}}^{\text{layer}} = M_{\text{symp}}^{(1)} / 3$

[0052] FIG. 11 shows layer mapping according to a 5th embodiment of the present invention. Herein, 6 antenna ports are used for layer mapping at ranks 1 to 6. When the receiver performs the SIC, layer mapping on each codeword is naturally increased according to a codeword index along with the increase of the ranks while codeword symbols mapped to each layer are equalized as much as possible, thereby optimizing codeword decoding performance. This can be shown by Table 10.

[0053] Table 10

[Table 10]

Number of layers	Number of codewords	Codeword-to-layer mapping, $i = 0, 1, \dots, M_{\text{symp}}^{\text{layer}} - 1$
1	1	$x^{(0)}(i) = d^{(0)}(i)$ $M_{\text{symp}}^{\text{layer}} = M_{\text{symp}}^{(0)}$
2	2	$x^{(0)}(i) = d^{(0)}(i)$ $x^{(1)}(i) = d^{(1)}(i)$ $M_{\text{symp}}^{\text{layer}} = M_{\text{symp}}^{(0)} = M_{\text{symp}}^{(1)}$
3	2	$x^{(0)}(i) = d^{(0)}(2i)$ $x^{(1)}(i) = d^{(0)}(2i + 1)$ $x^{(2)}(i) = d^{(1)}(i)$ $M_{\text{symp}}^{\text{layer}} = M_{\text{symp}}^{(0)} / 2 = M_{\text{symp}}^{(1)}$
4	2	$x^{(0)}(i) = d^{(0)}(2i)$ $x^{(1)}(i) = d^{(0)}(2i + 1)$ $x^{(2)}(i) = d^{(1)}(2i)$ $x^{(3)}(i) = d^{(1)}(2i + 1)$ $M_{\text{symp}}^{\text{layer}} = M_{\text{symp}}^{(0)} / 2 = M_{\text{symp}}^{(1)} / 2$
5	2	$x^{(0)}(i) = d^{(0)}(3i)$ $x^{(1)}(i) = d^{(0)}(3i + 1)$ $x^{(2)}(i) = d^{(0)}(3i + 2)$ $x^{(3)}(i) = d^{(1)}(2i)$ $x^{(4)}(i) = d^{(1)}(2i + 1)$ $M_{\text{symp}}^{\text{layer}} = M_{\text{symp}}^{(0)} / 3 = M_{\text{symp}}^{(1)} / 2$
6	2	$x^{(0)}(i) = d^{(0)}(3i)$ $x^{(1)}(i) = d^{(0)}(3i + 1)$ $x^{(2)}(i) = d^{(0)}(3i + 2)$ $x^{(3)}(i) = d^{(1)}(3i)$ $x^{(4)}(i) = d^{(1)}(3i + 1)$ $x^{(5)}(i) = d^{(1)}(3i + 2)$ $M_{\text{symp}}^{\text{layer}} = M_{\text{symp}}^{(0)} / 3 = M_{\text{symp}}^{(1)} / 3$

[0054] FIG. 12 shows extended mapping when layer mapping is performed according to the 5th embodiment of the present invention. The extended mapping is used to support HARQ retransmission or rank overriding, and this can be shown by Table 11.

[0055] Table 11

[Table 11]

Number of layers	Number of codewords	Codeword-to-layer mapping, $i = 0, 1, \dots, M_{\text{sy mb}}^{\text{layer}} - 1$
1	1	$x^{(0)}(i) = d^{(1)}(i)$ $M_{\text{sy mb}}^{\text{layer}} = M_{\text{sy mb}}^{(1)}$
2	1	$x^{(0)}(i) = d^{(n)}(2i)$ $x^{(1)}(i) = d^{(n)}(2i + 1)$ $M_{\text{sy mb}}^{\text{layer}} = M_{\text{sy mb}}^{(n)} / 2, \quad n = 1 \text{ or } 2$
3	1	$x^{(0)}(i) = d^{(n)}(3i)$ $x^{(1)}(i) = d^{(n)}(3i + 1)$ $x^{(2)}(i) = d^{(n)}(3i + 2)$ $M_{\text{sy mb}}^{\text{layer}} = M_{\text{sy mb}}^{(n)} / 3, \quad n = 1 \text{ or } 2$

[0056] FIG. 13 shows layer mapping according to a 6th embodiment of the present invention. Herein, 6 antenna ports are used for layer mapping at ranks 1 to 6. Only a single codeword is transmitted at the rank 2 or lower by basically using the layer mapping according to the 5th embodiment. Thus, when an SCI gain of the receiver is small, transmission performance can be improved by increasing a channel coding gain of the single codeword. This can be shown by Table 12.

[0057] Table 12

[Table 12]

Number of layers	Number of codewords	Codeword-to-layer mapping, $i = 0, 1, \dots, M_{\text{sy mb}}^{\text{layer}} - 1$
1	1	$x^{(0)}(i) = d^{(0)}(i)$ $M_{\text{sy mb}}^{\text{layer}} = M_{\text{sy mb}}^{(0)}$
2	1	$x^{(0)}(i) = d^{(0)}(2i)$ $x^{(1)}(i) = d^{(0)}(2i + 1)$ $M_{\text{sy mb}}^{\text{layer}} = M_{\text{sy mb}}^{(0)} / 2$
3	2	$x^{(0)}(i) = d^{(0)}(2i)$ $x^{(1)}(i) = d^{(0)}(2i + 1)$ $x^{(2)}(i) = d^{(1)}(i)$ $M_{\text{sy mb}}^{\text{layer}} = M_{\text{sy mb}}^{(0)} / 2 = M_{\text{sy mb}}^{(1)}$
4	2	$x^{(0)}(i) = d^{(0)}(2i)$ $x^{(1)}(i) = d^{(0)}(2i + 1)$ $x^{(2)}(i) = d^{(1)}(2i)$ $x^{(3)}(i) = d^{(1)}(2i + 1)$ $M_{\text{sy mb}}^{\text{layer}} = M_{\text{sy mb}}^{(0)} / 2 = M_{\text{sy mb}}^{(1)} / 2$
5	2	$x^{(0)}(i) = d^{(0)}(3i)$ $x^{(1)}(i) = d^{(0)}(3i + 1)$ $x^{(2)}(i) = d^{(0)}(3i + 2)$ $x^{(3)}(i) = d^{(1)}(2i)$ $x^{(4)}(i) = d^{(1)}(2i + 1)$ $M_{\text{sy mb}}^{\text{layer}} = M_{\text{sy mb}}^{(0)} / 3 = M_{\text{sy mb}}^{(1)} / 2$

(continued)

Number of layers	Number of codewords	Codeword-to-layer mapping, $i = 0, 1, \dots, M_{\text{symp}}^{\text{layer}} - 1$
6	2	$x^{(0)}(i) = d^{(0)}(3i)$ $x^{(1)}(i) = d^{(0)}(3i + 1)$ $x^{(2)}(i) = d^{(0)}(3i + 2)$ $x^{(3)}(i) = d^{(1)}(3i)$ $x^{(4)}(i) = d^{(1)}(3i + 1)$ $x^{(5)}(i) = d^{(1)}(3i + 2)$ $M_{\text{symp}}^{\text{layer}} = M_{\text{symp}}^{(0)}/3 = M_{\text{symp}}^{(1)}/3$

[0058] FIG. 14 shows extended mapping when layer mapping is performed according to the 6th embodiment of the present invention. The extended mapping is used to support HARQ retransmission or rank overriding, and this can be shown by Table 13.

[0059] Table 13

[Table 13]

Number of layers	Number of codewords	Codeword-to-layer mapping, $i = 0, 1, \dots, M_{\text{symp}}^{\text{layer}} - 1$
1	1	$x^{(0)}(i) = d^{(1)}(i)$ $M_{\text{symp}}^{\text{layer}} = M_{\text{symp}}^{(1)}$
2	1	$x^{(0)}(i) = d^{(1)}(2i)$ $x^{(1)}(i) = d^{(1)}(2i + 1)$ $M_{\text{symp}}^{\text{layer}} = M_{\text{symp}}^{(1)}/2$
3	1	$x^{(0)}(i) = d^{(n)}(3i)$ $x^{(1)}(i) = d^{(n)}(3i + 1)$ $x^{(2)}(i) = d^{(n)}(3i + 2)$ $M_{\text{symp}}^{\text{layer}} = M_{\text{symp}}^{(n)}/3, \quad n = 1 \text{ or } 2$

[0060] FIG. 15 shows layer mapping according to a 7th embodiment of the present invention. Herein, 6 antenna ports are used for layer mapping at ranks 1 to 6. Only a single codeword is transmitted at the rank 2 or lower by basically using the layer mapping according to the 5th embodiment. Thus, when the SCI gain of the receiver is small, transmission performance can be improved by increasing a channel coding gain of the single codeword. This can be shown by Table 14.

[0061] Table 14

[Table 14]

Number of layers	Number of codewords	Codeword-to-layer mapping, $i = 0, 1, \dots, M_{\text{symp}}^{\text{layer}} - 1$
1	1	$x^{(0)}(i) = d^{(0)}(i)$ $M_{\text{symp}}^{\text{layer}} = M_{\text{symp}}^{(0)}$
2	1	$x^{(0)}(i) = d^{(0)}(2i)$ $x^{(1)}(i) = d^{(0)}(2i + 1)$ $M_{\text{symp}}^{\text{layer}} = M_{\text{symp}}^{(0)}/2$
3	1	$x^{(0)}(i) = d^{(0)}(3i)$ $x^{(1)}(i) = d^{(0)}(3i + 1)$ $x^{(2)}(i) = d^{(0)}(3i + 2)$ $M_{\text{symp}}^{\text{layer}} = M_{\text{symp}}^{(0)}/3$

(continued)

5

10

15

20

Number of layers	Number of codewords	Codeword-to-layer mapping, $i = 0, 1, \dots, M_{\text{symp}}^{\text{layer}} - 1$
4	2	$x^{(0)}(i) = d^{(0)}(2i)$ $x^{(1)}(i) = d^{(0)}(2i + 1)$ $x^{(2)}(i) = d^{(1)}(2i)$ $x^{(3)}(i) = d^{(1)}(2i + 1)$ $M_{\text{symp}}^{\text{layer}} = M_{\text{symp}}^{(0)} / 2 = M_{\text{symp}}^{(1)} / 2$
5	2	$x^{(0)}(i) = d^{(0)}(3i)$ $x^{(1)}(i) = d^{(0)}(3i + 1)$ $x^{(2)}(i) = d^{(0)}(3i + 2)$ $x^{(3)}(i) = d^{(1)}(2i)$ $x^{(4)}(i) = d^{(1)}(2i + 1)$ $M_{\text{symp}}^{\text{layer}} = M_{\text{symp}}^{(0)} / 3 = M_{\text{symp}}^{(1)} / 2$
6	2	$x^{(0)}(i) = d^{(0)}(3i)$ $x^{(1)}(i) = d^{(0)}(3i + 1)$ $x^{(2)}(i) = d^{(0)}(3i + 2)$ $x^{(3)}(i) = d^{(1)}(3i)$ $x^{(4)}(i) = d^{(1)}(3i + 1)$ $x^{(5)}(i) = d^{(1)}(3i + 2)$ $M_{\text{symp}}^{\text{layer}} = M_{\text{symp}}^{(0)} / 3 = M_{\text{symp}}^{(1)} / 3$

25

[0062] FIG. 16 shows extended mapping when layer mapping is performed according to the 7th embodiment of the present invention. The extended mapping is used to support HARQ retransmission or rank overriding, and this can be shown by Table 15.

[0063] Table 15

30

[Table 15]

35

40

Number of layers	Number of codewords	Codeword-to-layer mapping, $i = 0, 1, \dots, M_{\text{symp}}^{\text{layer}} - 1$
2	1	$x^{(0)}(i) = d^{(1)}(2i)$ $x^{(1)}(i) = d^{(1)}(2i + 1)$ $M_{\text{symp}}^{\text{layer}} = M_{\text{symp}}^{(1)} / 2$
3	1	$x^{(0)}(i) = d^{(1)}(3i)$ $x^{(1)}(i) = d^{(1)}(3i + 1)$ $x^{(2)}(i) = d^{(1)}(3i + 2)$ $M_{\text{symp}}^{\text{layer}} = M_{\text{symp}}^{(1)} / 3$

45

[0064] FIG. 17 shows layer mapping according to an 8th embodiment of the present invention. Herein, 6 antenna ports are used for layer mapping at ranks 1 to 6.

[0065] Only a single codeword is transmitted at the rank 3 or lower by basically using the layer mapping according to the 5th embodiment. A change in an aspect of mapping each codeword to layers at different ranks is minimized. In transmission using active rank adaptation, disparity between the MCS used in transmission and the CQI reported by the UE depending on the rank change can be minimized. This can be shown by Table 16.

50

[0066] Table 16

55

[Table 16]

Number of layers	Number of codewords	Codeword-to-layer mapping, $i = 0, 1, \dots, M_{\text{symb}}^{\text{layer}} - 1$
1	1	$x^{(0)}(i) = d^{(0)}(i)$ $M_{\text{symb}}^{\text{layer}} = M_{\text{symb}}^{(0)}$
2	1	$x^{(0)}(i) = d^{(0)}(2i)$ $x^{(1)}(i) = d^{(0)}(2i + 1)$ $M_{\text{symb}}^{\text{layer}} = M_{\text{symb}}^{(0)} / 2$
3	1	$x^{(0)}(i) = d^{(0)}(3i)$ $x^{(1)}(i) = d^{(0)}(3i + 1)$ $x^{(2)}(i) = d^{(0)}(3i + 2)$ $M_{\text{symb}}^{\text{layer}} = M_{\text{symb}}^{(0)} / 3$
4	2	$x^{(0)}(i) = d^{(0)}(3i)$ $x^{(1)}(i) = d^{(0)}(3i + 1)$ $x^{(2)}(i) = d^{(0)}(3i + 2)$ $x^{(3)}(i) = d^{(1)}(i)$ $M_{\text{symb}}^{\text{layer}} = M_{\text{symb}}^{(0)} / 3 = M_{\text{symb}}^{(1)}$
5	2	$x^{(0)}(i) = d^{(0)}(3i)$ $x^{(1)}(i) = d^{(0)}(3i + 1)$ $x^{(2)}(i) = d^{(0)}(3i + 2)$ $x^{(3)}(i) = d^{(1)}(2i)$ $x^{(4)}(i) = d^{(1)}(2i + 1)$ $M_{\text{symb}}^{\text{layer}} = M_{\text{symb}}^{(0)} / 3 = M_{\text{symb}}^{(1)} / 2$
6	2	$x^{(0)}(i) = d^{(0)}(3i)$ $x^{(1)}(i) = d^{(0)}(3i + 1)$ $x^{(2)}(i) = d^{(0)}(3i + 2)$ $x^{(3)}(i) = d^{(1)}(3i)$ $x^{(4)}(i) = d^{(1)}(3i + 1)$ $x^{(5)}(i) = d^{(1)}(3i + 2)$ $M_{\text{symb}}^{\text{layer}} = M_{\text{symb}}^{(0)} / 3 = M_{\text{symb}}^{(1)} / 3$

[0067] FIG. 18 shows extended mapping when layer mapping is performed according to the 8th embodiment of the present invention. The extended mapping is used to support HARQ retransmission or rank overriding, and this can be shown by Table 17.

[0068] Table 17

[Table 17]

Number of layers	Number of codewords	Codeword-to-layer mapping, $i = 0, 1, \dots, M_{\text{symb}}^{\text{layer}} - 1$
1	1	$x^{(0)}(i) = d^{(1)}(i)$ $M_{\text{symb}}^{\text{layer}} = M_{\text{symb}}^{(1)}$
2	1	$x^{(0)}(i) = d^{(1)}(2i)$ $x^{(1)}(i) = d^{(1)}(2i + 1)$ $M_{\text{symb}}^{\text{layer}} = M_{\text{symb}}^{(1)} / 2$
3	1	$x^{(0)}(i) = d^{(1)}(3i)$ $x^{(1)}(i) = d^{(1)}(3i + 1)$ $x^{(2)}(i) = d^{(1)}(3i + 2)$ $M_{\text{symb}}^{\text{layer}} = M_{\text{symb}}^{(1)} / 3$

[0069] In layer mapping to be described now, 8 antenna ports are used at ranks 1 to 8.

[0070] FIG. 19 shows layer mapping according to a 9th embodiment of the present invention. At the rank 4 or higher, inter-layer interference may increase in proportion to the number of layers to be mapped for each codeword. Thus, codeword decoding performance can be optimized by equalizing codeword symbols to be mapped to each layer as

much as possible. This is for supporting backward compatibility with the 3GPP LTE. A mapping method for each rank can be shown by Tables 18 and 19.

[0071] Table 18

5

[Table 18]

10

15

20

25

30

35

Number of layers	Number of codewords	Codeword-to-layer mapping, $i = 0, 1, \dots, M_{\text{symbol}}^{\text{layer}} - 1$
1	1	$x^{(0)}(i) = d^{(0)}(i)$ $M_{\text{symbol}}^{\text{layer}} = M_{\text{symbol}}^{(0)}$
2	2	$x^{(0)}(i) = d^{(0)}$ $(i) x^{(1)}(i) = d^{(1)}(i)$ $M_{\text{symbol}}^{\text{layer}} = M_{\text{symbol}}^{(0)} = M_{\text{symbol}}^{(1)}$
3	2	$x^{(0)}(i) = d^{(0)}(i)$ $x^{(1)}(i) = d^{(1)}(2i)$ $x^{(2)}(i) = d^{(1)}(2i + 1)$ $M_{\text{symbol}}^{\text{layer}} = M_{\text{symbol}}^{(0)} = M_{\text{symbol}}^{(1)} / 2$
4	2	$x^{(0)}(i) = d^{(0)}(2i)$ $x^{(1)}(i) = d^{(0)}(2i + 1)$ $x^{(2)}(i) = d^{(1)}(2i)$ $x^{(3)}(i) = d^{(1)}(2i + 1)$ $M_{\text{symbol}}^{\text{layer}} = M_{\text{symbol}}^{(0)} / 2 = M_{\text{symbol}}^{(1)} / 2$
5	2	$x^{(0)}(i) = d^{(0)}(2i)$ $x^{(1)}(i) = d^{(0)}(2i + 1)$ $x^{(2)}(i) = d^{(1)}(3i)$ $x^{(3)}(i) = d^{(1)}(3i + 1)$ $x^{(4)}(i) = d^{(1)}(3i + 2)$ $M_{\text{symbol}}^{\text{layer}} = M_{\text{symbol}}^{(0)} / 2 = M_{\text{symbol}}^{(1)} / 3$
6	2	$x^{(0)}(i) = d^{(0)}(3i)$ $x^{(1)}(i) = d^{(0)}(3i + 1)$ $x^{(2)}(i) = d^{(0)}(3i + 2)$ $x^{(3)}(i) = d^{(1)}(3i)$ $x^{(4)}(i) = d^{(1)}(3i + 1)$ $x^{(5)}(i) = d^{(1)}(3i + 2)$ $M_{\text{symbol}}^{\text{layer}} = M_{\text{symbol}}^{(0)} / 3 = M_{\text{symbol}}^{(1)} / 3$

[0072] Table 19

40

[Table 19]

45

50

55

Number of layers	Number of codewords	Codeword-to-layer mapping, $i = 0, 1, \dots, M_{\text{symbol}}^{\text{layer}} - 1$
7	2	$x^{(0)}(i) = d^{(0)}(3i)$ $x^{(1)}(i) = d^{(0)}(3i + 1)$ $x^{(2)}(i) = d^{(0)}(3i + 2)$ $x^{(3)}(i) = d^{(1)}(4i)$ $x^{(4)}(i) = d^{(1)}(4i + 1)$ $x^{(5)}(i) = d^{(1)}(4i + 2)$ $x^{(6)}(i) = d^{(1)}(4i + 3)$ $M_{\text{symbol}}^{\text{layer}} = M_{\text{symbol}}^{(0)} / 3 = M_{\text{symbol}}^{(1)} / 4$
		$x^{(0)}(i) = d^{(0)}(4i)$ $x^{(1)}(i) = d^{(0)}(4i + 1)$ $x^{(2)}(i) = d^{(0)}(4i + 2)$

(continued)

Number of layers	Number of codewords	Codeword-to-layer mapping, $i = 0, 1, \dots, M_{\text{symb}}^{\text{layer}} - 1$
8	2	$x^{(3)}(i) = d^{(0)}(4i + 3)$ $x^{(4)}(i) = d^{(1)}(4i)$ $x^{(5)}(i) = d^{(1)}(4i + 1)$ $x^{(6)}(i) = d^{(1)}(4i + 2)$ $x^{(7)}(i) = d^{(1)}(4i + 3)$ $M_{\text{symb}}^{\text{layer}} = M_{\text{symb}}^{(0)}/4 = M_{\text{symb}}^{(1)}/4$

[0073] FIG. 20 shows extended mapping when layer mapping is performed according to the 9th embodiment of the present invention. The extended mapping is used to support HARQ retransmission or rank overriding, and this can be shown by Table 20.

[0074] Table 20

[Table 20]

Number of layers	Number of codewords	Codeword-to-layer mapping, $i = 0, 1, \dots, M_{\text{symb}}^{\text{layer}} - 1$
1	1	$x^{(0)}(i) = d^{(1)}(i)$ $M_{\text{symb}}^{\text{layer}} = M_{\text{symb}}^{(1)}$
2	1	$x^{(0)}(i) = d^{(n)}(2i)$ $x^{(1)}(i) = d^{(n)}(2i + 1)$ $M_{\text{symb}}^{\text{layer}} = M_{\text{symb}}^{(n)}/2, \quad n = 1 \text{ or } 2$
3	1	$x^{(0)}(i) = d^{(n)}(3i)$ $x^{(1)}(i) = d^{(n)}(3i + 1)$ $x^{(2)}(i) = d^{(n)}(3i + 2)$ $M_{\text{symb}}^{\text{layer}} = M_{\text{symb}}^{(n)}/3, \quad n = 1 \text{ or } 2$
4	1	$x^{(0)}(i) = d^{(n)}(4i)$ $x^{(1)}(i) = d^{(n)}(4i + 1)$ $x^{(2)}(i) = d^{(n)}(4i + 2)$ $x^{(3)}(i) = d^{(n)}(4i + 3)$ $M_{\text{symb}}^{\text{layer}} = M_{\text{symb}}^{(n)}/4, \quad n = 1 \text{ or } 2$

[0075] FIG. 21 shows layer mapping according to a 10th embodiment of the present invention. In single codeword transmission at a rank 2 or lower, transmission performance can be improved by increasing a channel coding gain of a codeword. This can be shown by Tables 21 and 22.

[0076] Table 21

[Table 21]

Number of layers	Number of codewords	Codeword-to-layer mapping, $i = 0, 1, \dots, M_{\text{symb}}^{\text{layer}} - 1$
1	1	$x^{(0)}(i) = d^{(0)}(i)$ $M_{\text{symb}}^{\text{layer}} = M_{\text{symb}}^{(0)}$
2	1	$x^{(0)}(i) = d^{(0)}(2i)$ $x^{(1)}(i) = d^{(0)}(2i + 1)$ $M_{\text{symb}}^{\text{layer}} = M_{\text{symb}}^{(0)}/2$

(continued)

5

10

15

20

25

Number of layers	Number of codewords	Codeword-to-layer mapping, $i = 0, 1, \dots, M_{\text{symp}}^{\text{layer}} - 1$
3	2	$x^{(0)}(i) = d^{(0)}(i)$ $x^{(1)}(i) = d^{(1)}(2i)$ $x^{(2)}(i) = d^{(1)}(2i + 1)$ $M_{\text{symp}}^{\text{layer}} = M_{\text{symp}}^{(0)} = M_{\text{symp}}^{(1)} / 2$
4	2	$x^{(0)}(i) = d^{(0)}(2i)$ $x^{(1)}(i) = d^{(0)}(2i + 1)$ $x^{(2)}(i) = d^{(1)}(2i)$ $x^{(3)}(i) = d^{(1)}(2i + 1)$ $M_{\text{symp}}^{\text{layer}} = M_{\text{symp}}^{(0)} / 2 = M_{\text{symp}}^{(1)} / 2$
5	2	$x^{(0)}(i) = d^{(0)}(2i)$ $x^{(1)}(i) = d^{(0)}(2i + 1)$ $x^{(2)}(i) = d^{(1)}(3i)$ $x^{(3)}(i) = d^{(1)}(3i + 1)$ $x^{(4)}(i) = d^{(1)}(3i + 2)$ $M_{\text{symp}}^{\text{layer}} = M_{\text{symp}}^{(0)} / 2 = M_{\text{symp}}^{(1)} / 3$
6	2	$x^{(0)}(i) = d^{(0)}(3i)$ $x^{(1)}(i) = d^{(0)}(3i + 1)$ $x^{(2)}(i) = d^{(0)}(3i + 2)$ $x^{(3)}(i) = d^{(1)}(3i)$ $x^{(4)}(i) = d^{(1)}(3i + 1)$ $x^{(5)}(i) = d^{(1)}(3i + 2)$ $M_{\text{symp}}^{\text{layer}} = M_{\text{symp}}^{(0)} / 3 = M_{\text{symp}}^{(1)} / 3$

[0077] Table 22

30

[Table 22]

35

40

45

50

Number of layers	Number of codewords	Codeword-to-layer mapping, $i = 0, 1, \dots, M_{\text{symp}}^{\text{layer}} - 1$
7	2	$x^{(0)}(i) = d^{(0)}(3i)$ $x^{(1)}(i) = d^{(0)}(3i + 1)$ $x^{(2)}(i) = d^{(0)}(3i + 2)$ $x^{(3)}(i) = d^{(1)}(4i)$ $x^{(4)}(i) = d^{(1)}(4i + 1)$ $x^{(5)}(i) = d^{(1)}(4i + 2)$ $x^{(6)}(i) = d^{(1)}(4i + 3)$ $M_{\text{symp}}^{\text{layer}} = M_{\text{symp}}^{(0)} / 3 = M_{\text{symp}}^{(1)} / 4$
8	2	$x^{(0)}(i) = d^{(0)}(4i)$ $x^{(1)}(i) = d^{(0)}(4i + 1)$ $x^{(2)}(i) = d^{(0)}(4i + 2)$ $x^{(3)}(i) = d^{(0)}(4i + 3)$ $x^{(4)}(i) = d^{(1)}(4i)$ $x^{(5)}(i) = d^{(1)}(4i + 1)$ $x^{(6)}(i) = d^{(1)}(4i + 2)$ $x^{(7)}(i) = d^{(1)}(4i + 3)$ $M_{\text{symp}}^{\text{layer}} = M_{\text{symp}}^{(0)} / 4 = M_{\text{symp}}^{(1)} / 4$

[0078] FIG. 22 shows extended mapping when layer mapping is performed according to the 10th embodiment of the present invention. The extended mapping is used to support HARQ retransmission or rank overriding, and this can be shown by Table 23.

[0079] Table 23

[Table 23]

Number of layers	Number of codewords	Codeword-to-layer mapping, $i = 0, 1, \dots, M_{\text{symb}}^{\text{layer}} - 1$
2	1	$x^{(0)}(i) = d^{(1)}(2i)$ $x^{(1)}(i) = d^{(1)}(2i + 1)$ $M_{\text{symb}}^{\text{layer}} = M_{\text{symb}}^{(1)} / 2$
3	1	$x^{(0)}(i) = d^{(n)}(3i)$ $x^{(1)}(i) = d^{(n)}(3i + 1)$ $x^{(2)}(i) = d^{(n)}(3i + 2)$ $M_{\text{symb}}^{\text{layer}} = M_{\text{symb}}^{(n)} / 3, \quad n = 1 \text{ or } 2$
4	1	$x^{(0)}(i) = d^{(n)}(4i)$ $x^{(1)}(i) = d^{(n)}(4i + 1)$ $x^{(2)}(i) = d^{(n)}(4i + 2)$ $x^{(3)}(i) = d^{(n)}(4i + 3)$ $M_{\text{symb}}^{\text{layer}} = M_{\text{symb}}^{(n)} / 4, \quad n = 1 \text{ or } 2$

[0080] FIG. 23 shows layer mapping according to an 11th embodiment of the present invention. In single codeword transmission at a rank 3 or lower, transmission performance can be improved by increasing a channel coding gain of a codeword. This can be shown by Tables 24 and 25.

[0081] Table 24

[Table 24]

Number of layers	Number of codewords	Codeword-to-layer mapping, $i = 0, 1, \dots, M_{\text{symb}}^{\text{layer}} - 1$
1	1	$x^{(0)}(i) = d^{(0)}(i)$ $M_{\text{symb}}^{\text{layer}} = M_{\text{symb}}^{(0)}$
2	1	$x^{(0)}(i) = d^{(0)}(2i)$ $x^{(1)}(i) = d^{(1)}(2i + 1)$ $M_{\text{symb}}^{\text{layer}} = M_{\text{symb}}^{(0)} / 2$
3	1	$x^{(0)}(i) = d^{(0)}(3i)$ $x^{(1)}(i) = d^{(0)}(3i + 1)$ $x^{(2)}(i) = d^{(0)}(3i + 2)$ $M_{\text{symb}}^{\text{layer}} = M_{\text{symb}}^{(0)} / 3$
4	2	$x^{(0)}(i) = d^{(0)}(2i)$ $x^{(1)}(i) = d^{(0)}(2i + 1)$ $x^{(2)}(i) = d^{(1)}(2i)$ $x^{(3)}(i) = d^{(1)}(2i + 1)$ $M_{\text{symb}}^{\text{layer}} = M_{\text{symb}}^{(0)} / 2 = M_{\text{symb}}^{(1)} / 2$
5	2	$x^{(0)}(i) = d^{(0)}(2i)$ $x^{(1)}(i) = d^{(0)}(2i + 1)$ $x^{(2)}(i) = d^{(1)}(3i)$ $x^{(3)}(i) = d^{(1)}(3i + 1)$ $x^{(4)}(i) = d^{(1)}(3i + 2)$ $M_{\text{symb}}^{\text{layer}} = M_{\text{symb}}^{(0)} / 2 = M_{\text{symb}}^{(1)} / 3$
6	2	$x^{(0)}(i) = d^{(0)}(3i)$ $x^{(1)}(i) = d^{(0)}(3i + 1)$ $x^{(2)}(i) = d^{(0)}(3i + 2)$ $x^{(3)}(i) = d^{(1)}(3i)$ $x^{(4)}(i) = d^{(1)}(3i + 1)$ $x^{(5)}(i) = d^{(1)}(3i + 2)$ $M_{\text{symb}}^{\text{layer}} = M_{\text{symb}}^{(0)} / 3 = M_{\text{symb}}^{(1)} / 3$

[0082] Table 25

[Table 25]

Number of layers	Number of codewords	Codeword-to-layer mapping, $i = 0, 1, \dots, M_{\text{symp}}^{\text{layer}} - 1$
7	2	$x^{(0)}(i) = d^{(0)}(3i)$ $x^{(1)}(i) = d^{(0)}(3i + 1)$ $x^{(2)}(i) = d^{(0)}(3i + 2)$ $x^{(3)}(i) = d^{(1)}(4i)$ $x^{(4)}(i) = d^{(1)}(4i + 1)$ $x^{(5)}(i) = d^{(1)}(4i + 2)$ $x^{(6)}(i) = d^{(1)}(4i + 3)$ $M_{\text{symp}}^{\text{layer}} = M_{\text{symp}}^{(0)}/3 = M_{\text{symp}}^{(1)}/4$
8	2	$x^{(0)}(i) = d^{(0)}(4i)$ $x^{(1)}(i) = d^{(0)}(4i + 1)$ $x^{(2)}(i) = d^{(0)}(4i + 2)$ $x^{(3)}(i) = d^{(0)}(4i + 3)$ $x^{(4)}(i) = d^{(1)}(4i)$ $x^{(5)}(i) = d^{(1)}(4i + 1)$ $x^{(6)}(i) = d^{(1)}(4i + 2)$ $x^{(7)}(i) = d^{(1)}(4i + 3)$ $M_{\text{symp}}^{\text{layer}} = M_{\text{symp}}^{(0)}/4 = M_{\text{symp}}^{(1)}/4$

[0083] FIG. 24 shows extended mapping when layer mapping is performed according to the 11th embodiment of the present invention. The extended mapping is used to support HARQ retransmission or rank overriding, and this can be shown by Table 26.

[0084] Table 26

[Table 26]

Number of layers	Number of codewords	Codeword-to-layer mapping, $i = 0, 1, \dots, M_{\text{symp}}^{\text{layer}} - 1$
2	1	$x^{(0)}(i) = d^{(1)}(2i)$ $x^{(1)}(i) = d^{(1)}(2i + 1)$ $M_{\text{symp}}^{\text{layer}} = M_{\text{symp}}^{(1)}/2$
3	1	$x^{(0)}(i) = d^{(1)}(3i)$ $x^{(1)}(i) = d^{(1)}(3i + 1)$ $x^{(2)}(i) = d^{(1)}(3i + 2)$ $M_{\text{symp}}^{\text{layer}} = M_{\text{symp}}^{(1)}/3$
4	1	$x^{(0)}(i) = d^{(n)}(4i)$ $x^{(1)}(i) = d^{(n)}(4i + 1)$ $x^{(2)}(i) = d^{(n)}(4i + 2)$ $x^{(3)}(i) = d^{(n)}(4i + 3)$ $M_{\text{symp}}^{\text{layer}} = M_{\text{symp}}^{(n)}/4, \quad n = 1 \text{ or } 2$

[0085] FIG. 25 shows layer mapping according to a 12th embodiment of the present invention. Only a single codeword is transmitted at a rank 3 or lower. A change in an aspect of mapping each codeword to layers at different ranks is minimized. In transmission using active rank adaptation, disparity between the MCS used in transmission and the CQI reported by the UE depending on the rank change can be minimized. This can be shown by Tables 27 and 28.

[0086] Table 27

[Table 27]

Number of layers	Number of codewords	Codeword-to-layer mapping, $i = 0, 1, \dots, M_{\text{symbol}}^{\text{layer}} - 1$
1	1	$x^{(0)}(i) = d^{(0)}(i)$ $M_{\text{symbol}}^{\text{layer}} = M_{\text{symbol}}^{(0)}$
2	1	$x^{(0)}(i) = d^{(0)}(2i)$ $x^{(1)}(i) = d^{(0)}(2i + 1)$ $M_{\text{symbol}}^{\text{layer}} = M_{\text{symbol}}^{(0)} / 2$
3	1	$x^{(0)}(i) = d^{(0)}(3i)$ $x^{(1)}(i) = d^{(0)}(3i + 1)$ $x^{(2)}(i) = d^{(0)}(3i + 2)$ $M_{\text{symbol}}^{\text{layer}} = M_{\text{symbol}}^{(0)} / 3$
4	2	$x^{(0)}(i) = d^{(0)}(3i)$ $x^{(1)}(i) = d^{(0)}(3i + 1)$ $x^{(2)}(i) = d^{(0)}(3i + 2)$ $x^{(3)}(i) = d^{(1)}(i)$ $M_{\text{symbol}}^{\text{layer}} = M_{\text{symbol}}^{(0)} / 3 = M_{\text{symbol}}^{(1)}$
5	2	$x^{(0)}(i) = d^{(0)}(2i)$ $x^{(1)}(i) = d^{(0)}(2i + 1)$ $x^{(2)}(i) = d^{(1)}(3i)$ $x^{(3)}(i) = d^{(1)}(3i + 1)$ $x^{(4)}(i) = d^{(1)}(3i + 2)$ $M_{\text{symbol}}^{\text{layer}} = M_{\text{symbol}}^{(0)} / 2 = M_{\text{symbol}}^{(1)} / 3$
6	2	$x^{(0)}(i) = d^{(0)}(3i)$ $x^{(1)}(i) = d^{(0)}(3i + 1)$ $x^{(2)}(i) = d^{(0)}(3i + 2)$ $x^{(3)}(i) = d^{(1)}(3i)$ $x^{(4)}(i) = d^{(1)}(3i + 1)$ $x^{(5)}(i) = d^{(1)}(3i + 2)$ $M_{\text{symbol}}^{\text{layer}} = M_{\text{symbol}}^{(0)} / 3 = M_{\text{symbol}}^{(1)} / 3$

[0087] Table 28

[Table 28]

Number of layers	Number of codewords	Codeword-to-layer mapping, $i = 0, 1, \dots, M_{\text{symbol}}^{\text{layer}} - 1$
7	2	$x^{(0)}(i) = d^{(0)}(3i)$ $x^{(1)}(i) = d^{(0)}(3i + 1)$ $x^{(2)}(i) = d^{(0)}(3i + 2)$ $x^{(3)}(i) = d^{(1)}(4i)$ $x^{(4)}(i) = d^{(1)}(4i + 1)$ $x^{(5)}(i) = d^{(1)}(4i + 2)$ $x^{(6)}(i) = d^{(1)}(4i + 3)$ $M_{\text{symbol}}^{\text{layer}} = M_{\text{symbol}}^{(0)} / 3 = M_{\text{symbol}}^{(1)} / 4$
8	2	$x^{(0)}(i) = d^{(0)}(4i)$ $x^{(1)}(i) = d^{(0)}(4i + 1)$ $x^{(2)}(i) = d^{(0)}(4i + 2)$ $x^{(3)}(i) = d^{(0)}(4i + 3)$ $x^{(4)}(i) = d^{(1)}(4i)$ $x^{(5)}(i) = d^{(1)}(4i + 1)$ $x^{(6)}(i) = d^{(1)}(4i + 2)$ $x^{(7)}(i) = d^{(1)}(4i + 3)$ $M_{\text{symbol}}^{\text{layer}} = M_{\text{symbol}}^{(0)} / 4 = M_{\text{symbol}}^{(1)} / 4$

[0088] FIG. 26 shows extended mapping in layer mapping according to the 12th embodiment of the present invention. The extended mapping is used to support HARQ retransmission or rank overriding, and this can be shown by Table 29.
 [0089] Table 29

5
10
15
20
25

[Table 29]

Number of layers	Number of codewords	Codeword-to-layer mapping, $i = 0, 1, \dots, M_{\text{symb}}^{\text{layer}} - 1$
1	1	$x^{(0)}(i) = d^{(1)}(i)$ $M_{\text{symb}}^{\text{layer}} = M_{\text{symb}}^{(1)}$
2	1	$x^{(0)}(i) = d^{(1)}(2i)$ $x^{(1)}(i) = d^{(1)}(2i + 1)$ $M_{\text{symb}}^{\text{layer}} = M_{\text{symb}}^{(1)} / 2$
3	1	$x^{(0)}(i) = d^{(1)}(3i)$ $x^{(1)}(i) = d^{(1)}(3i + 1)$ $x^{(2)}(i) = d^{(1)}(3i + 2)$ $M_{\text{symb}}^{\text{layer}} = M_{\text{symb}}^{(1)} / 3$
4	1	$x^{(0)}(i) = d^{(n)}(4i)$ $x^{(1)}(i) = d^{(n)}(4i + 1)$ $x^{(2)}(i) = d^{(n)}(4i + 2)$ $x^{(3)}(i) = d^{(n)}(4i + 3)$ $M_{\text{symb}}^{\text{layer}} = M_{\text{symb}}^{(n)} / 4, \quad n = 1 \text{ or } 2$

[0090] FIG. 27 shows layer mapping according to a 13th embodiment of the present invention. When the receiver performs the SIC, layer mapping on each codeword is naturally increased according to a codeword index along with the increase of the ranks while codeword symbols mapped to each layer are equalized as much as possible, thereby optimizing codeword decoding performance. This can be shown by Tables 30 and 31.

30

[0091] Table 30

[Table 30]

Number of layers	Number of codewords	Codeword-to-layer mapping, $i = 0, 1, \dots, M_{\text{symb}}^{\text{layer}} - 1$
1	1	$x^{(0)}(i) = d^{(0)}(i)$ $M_{\text{symb}}^{\text{layer}} = M_{\text{symb}}^{(0)}$
2	2	$x^{(0)}(i) = d^{(0)}(i)$ $x^{(1)}(i) = d^{(1)}(i)$ $M_{\text{symb}}^{\text{layer}} = M_{\text{symb}}^{(0)} = M_{\text{symb}}^{(1)}$
3	2	$x^{(0)}(i) = d^{(0)}(2i)$ $x^{(1)}(i) = d^{(0)}(2i + 1)$ $M_{\text{symb}}^{\text{layer}} = M_{\text{symb}}^{(0)} / 2 = M_{\text{symb}}^{(1)}$
4	2	$x^{(0)}(i) = d^{(0)}(2i)$ $x^{(1)}(i) = d^{(0)}(2i + 1)$ $x^{(2)}(i) = d^{(1)}(2i)$ $x^{(3)}(i) = d^{(1)}(2i + 1)$ $M_{\text{symb}}^{\text{layer}} = M_{\text{symb}}^{(0)} / 2 = M_{\text{symb}}^{(1)} / 2$
5	2	$x^{(0)}(i) = d^{(0)}(3i)$ $x^{(1)}(i) = d^{(0)}(3i + 1)$ $x^{(2)}(i) = d^{(0)}(3i + 2)$ $x^{(2)}(i) = d^{(1)}(2i)$ $x^{(4)}(i) = d^{(1)}(2i + 1)$ $M_{\text{symb}}^{\text{layer}} = M_{\text{symb}}^{(0)} / 3 = M_{\text{symb}}^{(1)} / 2$

35
40
45
50
55

(continued)

Number of layers	Number of codewords	Codeword-to-layer mapping, $i = 0, 1, \dots, M_{\text{symb}}^{\text{layer}} - 1$
6	2	$x^{(0)}(i) = d^{(0)}(3i)$ $x^{(1)}(i) = d^{(0)}(3i + 1)$ $x^{(2)}(i) = d^{(0)}(3i + 2)$ $x^{(3)}(i) = d^{(1)}(3i)$ $x^{(4)}(i) = d^{(1)}(3i + 1)$ $x^{(5)}(i) = d^{(1)}(3i + 2)$ $M_{\text{symb}}^{\text{layer}} = M_{\text{symb}}^{(0)}/3 = M_{\text{symb}}^{(1)}/3$

[0092] Table 31

[Table 31]

Number of layers	Number of codewords	Codeword-to-layer mapping, $i = 0, 1, \dots, M_{\text{symb}}^{\text{layer}} - 1$
7	2	$x^{(0)}(i) = d^{(0)}(4i)$ $x^{(1)}(i) = d^{(0)}(4i + 1)$ $x^{(2)}(i) = d^{(0)}(4i + 2)$ $x^{(3)}(i) = d^{(0)}(4i + 3)$ $x^{(4)}(i) = d^{(1)}(3i)$ $x^{(5)}(i) = d^{(1)}(3i + 1)$ $x^{(6)}(i) = d^{(1)}(3i + 2)$ $M_{\text{symb}}^{\text{layer}} = M_{\text{symb}}^{(0)}/4 = M_{\text{symb}}^{(1)}/3$
8	2	$x^{(0)}(i) = d^{(0)}(4i)$ $x^{(1)}(i) = d^{(0)}(4i + 1)$ $x^{(2)}(i) = d^{(0)}(4i + 2)$ $x^{(3)}(i) = d^{(0)}(4i + 3)$ $x^{(4)}(i) = d^{(1)}(4i)$ $x^{(5)}(i) = d^{(1)}(4i + 1)$ $x^{(6)}(i) = d^{(1)}(4i + 2)$ $x^{(7)}(i) = d^{(1)}(4i + 3)$ $M_{\text{symb}}^{\text{layer}} = M_{\text{symb}}^{(0)}/4 = M_{\text{symb}}^{(1)}/4$

[0093] FIG. 28 shows extended mapping when layer mapping is performed according to the 13th embodiment of the present invention. The extended mapping is used to support HARQ retransmission or rank overriding, and this can be shown by Table 32.

[0094] Table 32

[Table 32]

Number of layers	Number of codewords	Codeword-to-layer mapping, $i = 0, 1, \dots, M_{\text{symb}}^{\text{layer}} - 1$
1	1	$x^{(0)}(i) = d^{(1)}(i)$ $M_{\text{symb}}^{\text{layer}} = M_{\text{symb}}^{(1)}$
2	1	$x^{(0)}(i) = d^{(n)}(2i)$ $x^{(1)}(i) = d^{(n)}(2i + 1)$ $M_{\text{symb}}^{\text{layer}} = M_{\text{symb}}^{(n)}/2, \quad n = 1 \text{ or } 2$

(continued)

5

10

15

Number of layers	Number of codewords	Codeword-to-layer mapping, $i = 0, 1, \dots, M_{\text{symbol}}^{\text{layer}} - 1$
3	1	$x^{(0)}(i) = d^{(n)}(3i)$ $x^{(1)}(i) = d^{(n)}(3i + 1)$ $x^{(2)}(i) = d^{(n)}(3i + 2)$ $M_{\text{symbol}}^{\text{layer}} = M_{\text{symbol}}^{(n)} / 3, \quad n = 1 \text{ or } 2$
4	1	$x^{(0)}(i) = d^{(n)}(4i)$ $x^{(1)}(i) = d^{(n)}(4i + 1)$ $x^{(2)}(i) = d^{(n)}(4i + 2)$ $x^{(3)}(i) = d^{(n)}(4i + 3)$ $M_{\text{symbol}}^{\text{layer}} = M_{\text{symbol}}^{(n)} / 4, \quad n = 1 \text{ or } 2$

20

[0095] FIG. 29 shows layer mapping according to a 14th embodiment of the present invention. Only a single codeword is transmitted for a rank 2 or lower by basically using the layer mapping according to the 13th embodiment. Thus, when the SCI gain of the receiver is small, transmission performance can be improved by increasing a channel coding gain of the single codeword. This can be shown by Tables 33 and 34.

[0096] Table 33

[Table 33]

25

30

35

40

45

50

Number of layers	Number of codewords	Codeword-to-layer mapping, $i = 0, 1, \dots, M_{\text{symbol}}^{\text{layer}} - 1$
1	1	$x^{(0)}(i) = d^{(0)}(i)$ $M_{\text{symbol}}^{\text{layer}} = M_{\text{symbol}}^{(0)}$
2	1	$x^{(0)}(i) = d^{(0)}(2i)$ $x^{(1)}(i) = d^{(0)}(2i + 1)$ $M_{\text{symbol}}^{\text{layer}} = M_{\text{symbol}}^{(0)} / 2$
3	2	$x^{(0)}(i) = d^{(0)}(2i)$ $x^{(1)}(i) = d^{(0)}(2i + 1)$ $x^{(2)}(i) = d^{(1)}(i)$ $M_{\text{symbol}}^{\text{layer}} = M_{\text{symbol}}^{(0)} / 2 = M_{\text{symbol}}^{(1)}$
4	2	$x^{(0)}(i) = d^{(0)}(2i)$ $x^{(1)}(i) = d^{(0)}(2i + 1)$ $x^{(2)}(i) = d^{(1)}(2i)$ $x^{(3)}(i) = d^{(1)}(2i + 1)$ $M_{\text{symbol}}^{\text{layer}} = M_{\text{symbol}}^{(0)} / 2 = M_{\text{symbol}}^{(1)} / 2$
5	2	$x^{(0)}(i) = d^{(0)}(3i)$ $x^{(1)}(i) = d^{(0)}(3i + 1)$ $x^{(2)}(i) = d^{(0)}(3i + 2)$ $x^{(3)}(i) = d^{(1)}(2i)$ $x^{(4)}(i) = d^{(1)}(2i + 1)$ $M_{\text{symbol}}^{\text{layer}} = M_{\text{symbol}}^{(0)} / 3 = M_{\text{symbol}}^{(1)} / 2$
6	2	$x^{(0)}(i) = d^{(0)}(3i)$ $x^{(1)}(i) = d^{(0)}(3i + 1)$ $x^{(2)}(i) = d^{(0)}(3i + 2)$ $x^{(3)}(i) = d^{(1)}(3i)$ $x^{(4)}(i) = d^{(1)}(3i + 1)$ $x^{(5)}(i) = d^{(1)}(3i + 2)$ $M_{\text{symbol}}^{\text{layer}} = M_{\text{symbol}}^{(0)} / 3 = M_{\text{symbol}}^{(1)} / 3$

55

[0097] Table 34

[Table 34]

Number of layers	Number of codewords	Codeword-to-layer mapping, $i = 0, 1, \dots, M_{\text{symp}}^{\text{layer}} - 1$
7	2	$x^{(0)}(i) = d^{(0)}(4i)$ $x^{(1)}(i) = d^{(0)}(4i + 1)$ $x^{(2)}(i) = d^{(0)}(4i + 2)$ $x^{(3)}(i) = d^{(0)}(4i + 3)$ $x^{(4)}(i) = d^{(1)}(3i)$ $x^{(5)}(i) = d^{(1)}(3i + 1)$ $x^{(6)}(i) = d^{(1)}(3i + 2)$ $M_{\text{symp}}^{\text{layer}} = M_{\text{symp}}^{(0)} / 4 = M_{\text{symp}}^{(1)} / 3$
8	2	$x^{(0)}(i) = d^{(0)}(4i)$ $x^{(1)}(i) = d^{(0)}(4i + 1)$ $x^{(2)}(i) = d^{(0)}(4i + 2)$ $x^{(3)}(i) = d^{(0)}(4i + 3)$ $x^{(4)}(i) = d^{(1)}(4i)$ $x^{(5)}(i) = d^{(1)}(4i + 1)$ $x^{(6)}(i) = d^{(1)}(4i + 2)$ $x^{(7)}(i) = d^{(1)}(4i + 3)$ $M_{\text{symp}}^{\text{layer}} = M_{\text{symp}}^{(0)} / 4 = M_{\text{symp}}^{(1)} / 4$

[0098] FIG. 30 shows extended mapping when layer mapping is performed according to the 14th embodiment of the present invention. The extended mapping is used to support HARQ retransmission or rank overriding, and this can be shown by Table 35.

[0099] Table 35

[Table 35]

Number of layers	Number of codewords	Codeword-to-layer mapping, $i = 0, 1, \dots, M_{\text{symp}}^{\text{layer}} - 1$
1	1	$x^{(0)}(i) = d^{(1)}(i)$ $M_{\text{symp}}^{\text{layer}} = M_{\text{symp}}^{(1)}$
2	1	$x^{(0)}(i) = d^{(1)}(2i)$ $x^{(1)}(i) = d^{(1)}(2i+1)$ $M_{\text{symp}}^{\text{layer}} = M_{\text{symp}}^{(1)} / 2$
3	1	$x^{(0)}(i) = d^{(n)}(3i)$ $x^{(1)}(i) = d^{(n)}(3i + 1)$ $x^{(2)}(i) = d^{(n)}(3i + 2)$ $M_{\text{symp}}^{\text{layer}} = M_{\text{symp}}^{(n)} / 3, \quad n = 1 \text{ or } 2$
4	1	$x^{(0)}(i) = d^{(n)}(4i)$ $x^{(1)}(i) = d^{(n)}(4i + 1)$ $x^{(2)}(i) = d^{(n)}(4i + 2)$ $x^{(3)}(i) = d^{(n)}(4i + 3)$ $M_{\text{symp}}^{\text{layer}} = M_{\text{symp}}^{(n)} / 4, \quad n = 1 \text{ or } 2$

[0100] FIG. 31 shows layer mapping according to a 15th embodiment of the present invention. Only a single codeword is transmitted for a rank 3 or lower by basically using the layer mapping according to the 13th embodiment. Thus, when the SCI gain of the receiver is small, transmission performance can be improved by increasing a channel coding gain of the single codeword. This can be shown by Tables 36 and 37.

[0101] Table 36

[Table 36]

Number of layers	Number of codewords	Codeword-to-layer mapping, $i = 0, 1, \dots, M_{\text{symp}}^{\text{layer}} - 1$
1	1	$x^{(0)}(i) = d^{(0)}(i)$ $M_{\text{symp}}^{\text{layer}} = M_{\text{symp}}^{(0)}$
2	1	$x^{(0)}(i) = d^{(0)}(2i)$ $x^{(0)}(i) = d^{(0)}(2i + 1)$ $M_{\text{symp}}^{\text{layer}} = M_{\text{symp}}^{(0)} / 2$
3	1	$x^{(0)}(i) = d^{(0)}(3i)$ $x^{(1)}(i) = d^{(0)}(3i + 1)$ $x^{(2)}(i) = d^{(0)}(3i + 2)$ $M_{\text{symp}}^{\text{layer}} = M_{\text{symp}}^{(0)} / 3$
4	2	$x^{(0)}(i) = d^{(0)}(2i)$ $x^{(1)}(i) = d^{(0)}(2i + 1)$ $x^{(0)}(i) = d^{(1)}(2i)$ $x^{(3)}(i) = d^{(1)}(2i + 1)$ $M_{\text{symp}}^{\text{layer}} = M_{\text{symp}}^{(0)} / 2 = M_{\text{symp}}^{(1)} / 2$
5	2	$x^{(0)}(i) = d^{(0)}(3i)$ $x^{(1)}(i) = d^{(0)}(3i + 1)$ $x^{(2)}(i) = d^{(0)}(3i + 2)$ $x^{(3)}(i) = d^{(1)}(2i)$ $x^{(4)}(i) = d^{(1)}(2i + 1)$ $M_{\text{symp}}^{\text{layer}} = M_{\text{symp}}^{(0)} / 3 = M_{\text{symp}}^{(1)} / 2$
6	2	$x^{(0)}(i) = d^{(0)}(3i)$ $x^{(1)}(i) = d^{(0)}(3i + 1)$ $x^{(2)}(i) = d^{(0)}(3i + 2)$ $x^{(3)}(i) = d^{(1)}(3i)$ $x^{(4)}(i) = d^{(1)}(3i + 1)$ $x^{(5)}(i) = d^{(1)}(3i + 2)$ $M_{\text{symp}}^{\text{layer}} = M_{\text{symp}}^{(0)} / 3 = M_{\text{symp}}^{(1)} / 3$

[0102] Table 37

[Table 37]

Number of layers	Number of codewords	Codeword-to-layer mapping, $i = 0, 1, \dots, M_{\text{symp}}^{\text{layer}} - 1$
7	2	$x^{(0)}(i) = d^{(0)}(4i)$ $x^{(1)}(i) = d^{(0)}(4i + 1)$ $x^{(2)}(i) = d^{(0)}(4i + 2)$ $x^{(3)}(i) = d^{(0)}(4i + 3)$ $x^{(4)}(i) = d^{(1)}(3i)$ $x^{(5)}(i) = d^{(1)}(3i + 1)$ $x^{(6)}(i) = d^{(1)}(3i + 2)$ $M_{\text{symp}}^{\text{layer}} = M_{\text{symp}}^{(0)} / 4 = M_{\text{symp}}^{(1)} / 3$

(continued)

Number of layers	Number of codewords	Codeword-to-layer mapping, $i = 0, 1, \dots, M_{\text{symp}}^{\text{layer}} - 1$
8	2	$x^{(0)}(i) = d^{(0)}(4i)$ $x^{(1)}(i) = d^{(0)}(4i + 1)$ $x^{(2)}(i) = d^{(0)}(4i + 2)$ $x^{(3)}(i) = d^{(0)}(4i + 3)$ $x^{(4)}(i) = d^{(1)}(4i)$ $x^{(5)}(i) = d^{(1)}(4i + 1)$ $x^{(6)}(i) = d^{(1)}(4i + 2)$ $x^{(7)}(i) = d^{(1)}(4i + 3)$ $M_{\text{symp}}^{\text{layer}} = M_{\text{symp}}^{(0)}/4 = M_{\text{symp}}^{(1)}/4$

[0103] FIG. 32 shows extended mapping when layer mapping is performed according to the 15th embodiment of the present invention. The extended mapping is used to support HARQ retransmission or rank overriding, and this can be shown by Table 38.

[0104] Table 38

[Table 38]

Number of layers	Number of codewords	Codeword-to-layer mapping, $i = 0, 1, \dots, M_{\text{symp}}^{\text{layer}} - 1$
2	1	$x^{(0)}(i) = d^{(1)}(2i)$ $x^{(1)}(i) = d^{(1)}(2i + 1)$ $M_{\text{symp}}^{\text{layer}} = M_{\text{symp}}^{(1)}/2$
3	1	$x^{(0)}(i) = d^{(1)}(3i)$ $x^{(1)}(i) = d^{(1)}(3i + 1)$ $x^{(2)}(i) = d^{(1)}(3i + 2)$ $M_{\text{symp}}^{\text{layer}} = M_{\text{symp}}^{(1)}/3$
4	1	$x^{(0)}(i) = d^{(n)}(4i)$ $x^{(1)}(i) = d^{(n)}(4i + 1)$ $x^{(2)}(i) = d^{(n)}(4i + 2)$ $x^{(3)}(i) = d^{(n)}(4i + 3)$ $M_{\text{symp}}^{\text{layer}} = M_{\text{symp}}^{(n)}/4, \quad n = 1 \text{ or } 2$

[0105] FIG. 33 shows layer mapping according to a 16th embodiment of the present invention. Only a single codeword is transmitted for a rank 3 or lower by basically using the layer mapping according to the 13th embodiment.

[0106] A change in an aspect of mapping each codeword to layers at different ranks is minimized. In transmission using active rank adaptation, disparity between the MCS used in transmission and the CQI reported by the UE depending on the rank change can be minimized. This can be shown by Tables 39 and 40.

[0107] Table 39

[Table 39]

Number of layers	Number of codewords	Codeword-to-layer mapping, $i = 0, 1, \dots, M_{\text{symp}}^{\text{layer}} - 1$
1	1	$x^{(0)}(i) = d^{(0)}(i)$ $M_{\text{symp}}^{\text{layer}} = M_{\text{symp}}^{(0)}$
2	1	$x^{(0)}(i) = d^{(0)}(2i)$ $x^{(1)}(i) = d^{(0)}(2i + 1)$ $M_{\text{symp}}^{\text{layer}} = M_{\text{symp}}^{(0)}/2$

(continued)

Number of layers	Number of codewords	Codeword-to-layer mapping, $i = 0, 1, \dots, M_{\text{symp}}^{\text{layer}} - 1$
3	1	$x^{(0)}(i) = d^{(0)}(3i)$ $x^{(1)}(i) = d^{(0)}(3i + 1)$ $x^{(2)}(i) = d^{(0)}(3i + 2)$ $M_{\text{symp}}^{\text{layer}} = M_{\text{symp}}^{(0)} / 3$
4	2	$x^{(0)}(i) = d^{(0)}(3i)$ $x^{(1)}(i) = d^{(0)}(3i + 1)$ $x^{(2)}(i) = d^{(0)}(3i + 2)$ $x^{(3)}(i) = d^{(1)}(i)$ $M_{\text{symp}}^{\text{layer}} = M_{\text{symp}}^{(0)} / 3 = M_{\text{symp}}^{(1)}$
5	2	$x^{(0)}(i) = d^{(0)}(3i)$ $x^{(1)}(i) = d^{(0)}(3i + 1)$ $x^{(2)}(i) = d^{(0)}(3i + 2)$ $x^{(3)}(i) = d^{(1)}(2i)$ $x^{(4)}(i) = d^{(1)}(2i + 1)$ $M_{\text{symp}}^{\text{layer}} = M_{\text{symp}}^{(0)} / 3 = M_{\text{symp}}^{(1)} / 2$
6	2	$x^{(0)}(i) = d^{(0)}(3i)$ $x^{(1)}(i) = d^{(0)}(3i + 1)$ $x^{(2)}(i) = d^{(0)}(3i + 2)$ $x^{(3)}(i) = d^{(1)}(3i)$ $x^{(4)}(i) = d^{(1)}(3i + 1)$ $x^{(5)}(i) = d^{(1)}(3i + 2)$ $M_{\text{symp}}^{\text{layer}} = M_{\text{symp}}^{(0)} / 3 = M_{\text{symp}}^{(1)} / 3$

[0108] Table 40

[Table 40]

Number of layers	Number of codewords	Codeword-to-layer mapping, $i = 0, 1, \dots, M_{\text{symp}}^{\text{layer}} - 1$
7	2	$x^{(0)}(i) = d^{(0)}(4i)$ $x^{(1)}(i) = d^{(0)}(4i + 1)$ $x^{(2)}(i) = d^{(0)}(4i + 2)$ $x^{(3)}(i) = d^{(0)}(4i + 3)$ $x^{(4)}(i) = d^{(1)}(3i)$ $x^{(5)}(i) = d^{(1)}(3i + 1)$ $x^{(6)}(i) = d^{(1)}(3i + 2)$ $M_{\text{symp}}^{\text{layer}} = M_{\text{symp}}^{(0)} / 4 = M_{\text{symp}}^{(1)} / 3$
8	2	$x^{(0)}(i) = d^{(0)}(4i)$ $x^{(1)}(i) = d^{(0)}(4i + 1)$ $x^{(2)}(i) = d^{(0)}(4i + 2)$ $x^{(3)}(i) = d^{(0)}(4i + 3)$ $x^{(4)}(i) = d^{(1)}(4i)$ $x^{(5)}(i) = d^{(1)}(4i + 1)$ $x^{(6)}(i) = d^{(1)}(4i + 2)$ $x^{(7)}(i) = d^{(0)}(4i + 3)$ $M_{\text{symp}}^{\text{layer}} = M_{\text{symp}}^{(0)} / 4 = M_{\text{symp}}^{(1)} / 4$

[0109] FIG. 34 shows extended mapping when layer mapping is performed according to the 16th embodiment of the present invention. The extended mapping is used to support HARQ retransmission or rank overriding, and this can be shown by Table 41.

[0110] Table 41

[Table 41]

Number of layers	Number of codewords	Codeword-to-layer mapping, $i = 0, 1, \dots, M_{\text{sy mb}}^{\text{layer}} - 1$
1	1	$x^{(0)}(i) = d^{(1)}(i)$ $M_{\text{sy mb}}^{\text{layer}} = M_{\text{sy mb}}^{(1)}$
2	1	$x^{(0)}(i) = d^{(1)}(2i)$ $x^{(1)}(i) = d^{(1)}(2i + 1)$ $M_{\text{sy mb}}^{\text{layer}} = M_{\text{sy mb}}^{(1)} / 2$
3	1	$x^{(0)}(i) = d^{(1)}(3i)$ $x^{(1)}(i) = d^{(1)}(3i + 1)$ $x^{(2)}(i) = d^{(1)}(3i + 2)$ $M_{\text{sy mb}}^{\text{layer}} = M_{\text{sy mb}}^{(1)} / 3$
4	1	$x^{(0)}(i) = d^{(n)}(4i)$ $x^{(1)}(i) = d^{(n)}(4i + 1)$ $x^{(2)}(i) = d^{(n)}(4i + 2)$ $x^{(3)}(i) = d^{(n)}(4i + 3)$ $M_{\text{sy mb}}^{\text{layer}} = M_{\text{sy mb}}^{(n)} / 4, \quad n = 1 \text{ or } 2$

[0111] According to the aforementioned embodiments, layer mapping methods for all possible ranks with respect to 6 antenna ports and 8 antenna ports are introduced for exemplary purposes only. Various modifications can be made therein by those skilled in the art by combining some or all of the mapping methods described in these embodiments.

[0112] Extended mapping is a combination of available layers when the number of available layers is decreased in basic layer mapping. If layer mapping which is a basis of the extended mapping is referred to as basic mapping, the number of available layers is decreased for the following reasons. First, HARQ transmission is one of the reasons. It is assumed that, in the basic mapping, the first codeword and the second codeword are initially transmitted, and transmission of the first codeword is successful whereas transmission of the second codeword fails. Since it is sufficient to retransmit the second codeword, the extended mapping is defined for the retransmission of the second codeword. Second, rank overriding or restriction is one of the reasons. Although the basis mapping is used between the BS and the UE, if necessary, the BS may use only some ranks or some parts of a precoding matrix index (PMI). As the number of layers is decreased, there is a need to define the extended mapping.

[0113] FIG. 35 is a flow diagram showing triggering from basic mapping to extended mapping by HARQ retransmission. In step S810, a BS transmits a first codeword CW1 and a second codeword CW2 to a UE by using basic mapping. For example, the basic mapping may be performed when a rank is 2 in the embodiment of FIG. 3. The BS may report control information for decoding of the first codeword CW1 and the second codeword CW2, e.g., an MCS index of the first codeword CW1 and an MCS index of the second codeword CW2, to the UE.

[0114] In step S820, since no error is detected from the first codeword CW1, and an error is detected from the second codeword CW2, thus the UE transmits an acknowledgement (ACK) signal for the first codeword CW1, and transmits a negative-ACK (NACK) signal for the second codeword CW2.

[0115] In step S830, the BS retransmits the second codeword CW2 by using the extended mapping. For example, the extended mapping may be performed when a rank is 1 in the embodiment of FIG. 4 which is extended mapping for layer mapping of the embodiment of FIG. 3. To indicate the extended mapping, triggering to the extended mapping may be indicated by using a triggering indicator. Some parts of the retransmitted control information for decoding of the second codeword CW2 may be set to a specific value. For example, when the MCS index is set to the specific value, the UE can confirm that the extended mapping is used in transmission.

[0116] Although downlink HARQ is exemplified, the present invention is not limited thereto. Thus, the present invention may also apply to uplink HARQ in which the UE transmits uplink data and in which the BS requests retransmission.

[0117] FIG. 36 is a flowchart showing triggering from basic mapping to extended mapping. In step S910, the basic mapping is established between a BS and a UE. The basic mapping is a basic layer mapping scheme for transmitting and/or receiving data between the BS and the UE. In step S920, the BS determines whether the extended mapping is used. The extended mapping may be used when the UE is instructed to report a channel condition for a restricted rank. Alternatively, the extended mapping may be used for HARQ transmission. The extended mapping may also be used when layer mapping is performed for downlink data in a state that the rank reported by the UE is overridden. In step

S930, the BS instructs the use of extended mapping. The BS reports the use of extended mapping to the UE so that the UE is ready to perform an operation based on the extended mapping.

[0118] FIG. 37 is a flowchart showing a method of data transmission according to an embodiment of the present invention. This method may be carried in a BS at downlink transmission or in a UE at uplink transmission.

[0119] In step S1010, the number of layers is determined. In step S1020, mapping symbols are generated by mapping modulation symbols for a first codeword and modulation symbols for a second codeword to each layer. At least one of the first codeword and the second codeword may be mapped to 3 layers and the number of layers may be larger than 3. Layer mapping schemes shown in FIGs. 3-34 may be used. In step S1030, the mapping symbols are transmitted through a plurality of antennas.

[0120] The number of layers may be changed in order to perform HARQ or rank overriding. In step S1040, the number of layers is changed. The number of layers after changed may be smaller than the number of layers before changed. In step S1050, new mapping symbols is generated by mapping the modulation symbols for the first codeword or the mapping modulation symbols for the second codeword to each layer. Layer mapping schemes shown in FIGs. 3-34 may be used. In step S1060, the new mapping symbols are transmitted through the plurality of antennas.

[0121] FIG. 38 is a block diagram showing a transmitter according to an embodiment of the present invention. A transmitter 900 includes a processor 910 and a radio frequency (RF) unit 920. The processor 910 may implements at least one embodiment among embodiments shown in FIGs. 3-37. The RF unit 920 is connected to the processor 910 to transmit and/or receive radio signals through multiple Tx antennas. In uplink, the transmitter 900 may be a part of a UE. In downlink, the transmitter 900 may be a part of a BS.

[0122] FIG. 39 is a flowchart showing a method of communication according to an embodiment of the present invention. This method may be carried in a UE at downlink transmission or in a BS at uplink transmission.

[0123] In step S1110, the number of layers is acquired. The number of layers may be larger than 3. The number of layers may be received through system information, a RRC message or resource assignment.

[0124] In step S 1120, mapping symbols are received. The mapping symbols may be mapped to each layer according to one layer mapping schemes shown in FIGs. 3-34.

[0125] In step S1130, the mapping symbols are demapped to generate modulation symbols for a first codeword or modulation symbols for a second codeword. At least one of the first codeword and the second codeword may be mapped to at least 3 layers.

[0126] After demapping, the first codeword may be reproduced from the modulation symbols for the first codeword. The second codeword may be reproduced from the modulation symbols for the second codeword. The reproducing the codeword from modulation symbols may be achieved by performing demodulation and decoding well known in the skilled art.

[0127] It can be understood that skilled in the art may reproduce a codeword from mapping symbols by reversely performing procedure shown in embodiments of FIG. 37 or apparatus of FIG. 2.

[0128] The layer mapping methods or other methods described in the aforementioned embodiments can be performed only at some ranks. For example, ranks 1, 2, 4, and 6 may be used in a system having 6 antenna ports, and ranks 1, 2, 4, 6, and 8 may be used in a system having 8 antenna ports. That is, instead of using all possible ranks, only some ranks may be used by considering a signal overhead, system complexity, and difference in performance of each rank. An available rank may be predetermined, or may be reported by the BS to the UE through upper layer signaling or L1/L2 signaling.

[0129] In case of upper layer signaling, an RRC parameter of "Codebook subset restriction indicator" with an extended bit-width (i.e., bit-map size) may be used to indicate the situation of restricted rank utilization. In case of predetermination, an RRC parameter of "codebookSubsetRestriction" may have the bit-width in which the states of this RRC parameter express the additional restriction of PMI usage for given available rank cases.

[0130] The layer mapping methods or other methods described in the aforementioned embodiments may be used by combining some ranks. For example, ranks 1 to 3 may be selected in the layer mapping method of the 1st embodiment and ranks 4 to 6 may be selected in the layer mapping method of the 2nd embodiment, so that a layer mapping method obtained by combining the two methods is used in a system having 6 antenna ports. For another example, among mapping methods of the respective embodiments, at least one mapping method corresponding to each rank may be selected to configure a new mapping method by combining the selected mapping methods. In addition, among extended mapping methods of the respective embodiments, at least one extended mapping method corresponding to each rank may be selected to configure a new extended mapping method by combining the selected extended mapping methods.

[0131] In the aforementioned embodiments, $M_{\text{symb}}^{(q)}$ may denote a total number of modulation symbols for a codeword q , or may denote the number of some modulation symbols constituting the codeword q . That is, if $M_{\text{symb}}^{(q),\text{tot}}$ denotes a total number of modulation symbols for the codeword q , the following relation may be satisfied: $1 < M_{\text{symb}}^{(q)} \leq M_{\text{symb}}^{(q),\text{tot}}$. If $M_{\text{symb}}^{(q)} = M_{\text{symb}}^{(q),\text{tot}}$, the basic layer mapping may be $M_{\text{symb}}^{(q)} < M_{\text{symb}}^{(q),\text{tot}}$ in case of extended mapping for the basic layer mapping. $M_{\text{symb}}^{(q)}$ in use may differ for each rank.

[0132] In the aforementioned embodiments, it is introduced that layers mapped to each codeword are sequentially

mapped in an index order. However, indices of the layers may vary according to time or other situations. The indices of the layers may vary by a predetermined offset or in an arbitrary manner. Alternatively, the indices of the layers may vary by an offset predetermined according to a specific period or may vary in an arbitrary manner.

[0133] The layer mapping and/or extended mapping methods of each embodiment may be combined in a cell unit and/or a time unit. For example, the layer mapping of the 1st embodiment is used for all or some ranks at a first time slot, and the layer mapping of the 2nd embodiment may be used for all or some ranks at a second time slot.

[0134] The present invention can be implemented with hardware, software, or combination thereof. In hardware implementation, the present invention can be implemented with one of an application specific integrated circuit (ASIC), a digital signal processor (DSP), a programmable logic device (PLD), a field programmable gate array (FPGA), a processor, a controller, a microprocessor, other electronic units, and combination thereof, which are designed to perform the aforementioned functions. In software implementation, the present invention can be implemented with a module for performing the aforementioned functions. Software is storable in a memory unit and executed by the processor. Various means widely known to those skilled in the art can be used as the memory unit or the processor.

[0135] While the present invention has been particularly shown and described with reference to exemplary embodiments thereof, it will be understood by those skilled in the art that various changes in form and details may be made therein without departing from the scope of the invention as defined by the appended claims. The exemplary embodiments should be considered in descriptive sense only and not for purposes of limitation. Therefore, the scope of the invention is defined not by the detailed description of the invention but by the appended claims, and all differences within the scope will be construed as being included in the present invention.

Claims

1. A method of data transmission in a multiple antenna system, the method comprising:

generating mapping symbols by mapping modulation symbols for a first codeword and modulation symbols for a second codeword to a plurality of layers; and transmitting the mapping symbols through a plurality of antennas,

characterized in that when a number of the plurality of layers is larger than 4, at least one of the modulation symbols for the first codeword and the modulation symbols for the second codeword is mapped to at least 3 layers, wherein when the number of the plurality of layers is 5, the modulation symbols for the first codeword are mapped to 2 layers and the modulation symbols for the second codeword are mapped to remaining 3 layers, and when the number of the plurality of layers is 6, the modulation symbols for the first codeword are mapped to 3 layers and the modulation symbols for the second codeword are mapped to remaining 3 layers, and when the number of the plurality of layers is 7, the modulation symbols for the first codeword are mapped to 3 layers and the modulation symbols for the second codeword are mapped to remaining 4 layers, and when the number of the plurality of layers is 8, the modulation symbols for the first codeword are mapped to 4 layers and the modulation symbols for the second codeword are mapped to remaining 4 layers.

2. The method of claim 1, wherein the number of the plurality of layers is smaller than or equal to a number of the plurality of antennas.

3. The method of claim 1, further comprising: determining the number of the plurality of layers.

4. The method of claim 1, wherein when the number of the plurality of layers is 5, 6, 7 or 8, the modulation symbols for the first codeword and the modulation symbols for the second codeword are mapped to layers according to the following table:

Number of the plurality of layers	Number of codewords	Codeword-to-layer mapping $i = 0, 1, \dots, M_{\text{layer_symb}}^{\text{layer}} - 1,$ $M_{\text{layer_symb}}^{\text{layer}}$: a number of modulation symbols for each layer of the plurality of layers
5	2	$x^{(0)}(i) = d^{(0)}(2i)$ $x^{(1)}(i) = d^{(0)}(2i+1)$ $x^{(2)}(i) = d^{(1)}(3i)$ $M_{\text{layer_symb}}^{\text{layer}} = M^{(0)}_{\text{symb}}/2 = M^{(1)}_{\text{symb}}/3$

(continued)

Number of the plurality of layers	Number of codewords	Codeword-to-layer mapping $i = 0, 1, \dots, M^{\text{layer}}_{\text{symb}} - 1$, $M^{\text{layer}}_{\text{symb}}$: a number of modulation symbols for each layer of the plurality of layers
		$x^{(3)}(i) = d^{(1)}(3i+1)$ $x^{(4)}(i) = d^{(1)}(3i+2)$
6	2	$x^{(0)}(i) = d^{(0)}(3i)$ $x^{(1)}(i) = d^{(0)}(3i+1)$ $x^{(2)}(i) = d^{(0)}(3i+2)$ $x^{(3)}(i) = d^{(1)}(3i)$ $x^{(4)}(i) = d^{(1)}(3i+1)$ $x^{(5)}(i) = d^{(1)}(3i+2)$ $M^{\text{layer}}_{\text{symb}} = M^{(0)}_{\text{symb}}/3 = M^{(1)}_{\text{symb}}/3$
7	2	$x^{(0)}(i) = d^{(0)}(3i)$ $x^{(1)}(i) = d^{(0)}(3i+1)$ $x^{(2)}(i) = d^{(0)}(3i+2)$ $x^{(3)}(i) = d^{(1)}(4i)$ $x^{(4)}(i) = d^{(1)}(4i+1)$ $x^{(5)}(i) = d^{(1)}(4i+2)$ $x^{(6)}(i) = d^{(1)}(4i+3)$ $M^{\text{layer}}_{\text{symb}} = M^{(0)}_{\text{symb}}/3 = M^{(1)}_{\text{symb}}/4$
8	2	$x^{(0)}(i) = d^{(0)}(4i)$ $x^{(1)}(i) = d^{(0)}(4i+1)$ $x^{(2)}(i) = d^{(0)}(4i+2)$ $x^{(3)}(i) = d^{(0)}(4i+3)$ $x^{(4)}(i) = d^{(1)}(4i)$ $x^{(5)}(i) = d^{(1)}(4i+1)$ $x^{(6)}(i) = d^{(1)}(4i+2)$ $x^{(7)}(i) = d^{(1)}(4i+3)$ $M^{\text{layer}}_{\text{symb}} = M^{(0)}_{\text{symb}}/4 = M^{(1)}_{\text{symb}}/4$

wherein in the above table, $d^{(0)}(i)$ is the modulation symbols for the first codeword, $d^{(1)}(i)$ is the modulation symbols for the second codeword, $x^{(n)}(i)$ is mapping symbols mapped to layer n , $M^{(0)}_{\text{symb}}$ is a number of modulation symbols for the first codeword and $M^{(1)}_{\text{symb}}$ is a number of modulation symbols for the second codeword.

5. A transmitter (900) comprising:

- a radio frequency, RF, unit (920) for transmitting and receiving a radio signal; and
- a processor (910) coupled to the RF unit,

wherein the processor (910) generates mapping symbols by mapping modulation symbols for a first codeword and modulation symbols for a second codeword to a plurality of layers, and transmits the mapping symbols, **characterized in that** when a number of the plurality of layers is larger than 4, at least one of the modulation symbols for first codeword and the modulation symbols for the second codeword is mapped to at least 3 layers and, wherein when the number of the plurality of layers is 5, the modulation symbols for the first codeword are mapped to 2 layers and the modulation symbols for the second codeword are mapped to remaining 3 layers, and when the number of the plurality of layers is 6, the modulation symbols for the first codeword are mapped to 3 layers and the modulation symbols for the second codeword are mapped to remaining 3 layers, and when the number of the plurality of layers is 7, the modulation symbols for the first codeword are mapped to 3 layers and the modulation symbols for the second codeword are mapped to remaining 4 layers, and when the number of the plurality of layers is 8, the modulation symbols for the first codeword are mapped to 4 layers and the modulation symbols for the second codeword are mapped to remaining 4 layers.

6. The transmitter (900) of claim 5,

wherein when the number of the plurality of layers is 5, 6, 7 or 8, the modulation symbols for the first codeword and

EP 2 263 328 B1

the modulation symbols for the second codeword are mapped to layers according to the following table:

Number of the plurality of layers	Number of codewords	Codeword-to-layer mapping $i = 0, 1, \dots, M_{\text{layer_symb}}^{\text{layer}} - 1$, $M_{\text{layer_symb}}^{\text{layer}}$: a number of modulation symbols for each layer of the plurality of layers
5	2	$x^{(0)}(i) = d^{(0)}(2i)$ $x^{(1)}(i) = d^{(0)}(2i+1)$ $x^{(2)}(i) = d^{(1)}(3i)$ $M_{\text{layer_symb}}^{\text{layer}} = M_{\text{symb}}^{(0)}/2 = M_{\text{symb}}^{(1)}/3$ $x^{(3)}(i) = d^{(1)}(3i+1)$ $x^{(4)}(i) = d^{(1)}(3i+2)$
6	2	$x^{(0)}(i) = d^{(0)}(3i)$ $x^{(1)}(i) = d^{(0)}(3i+1)$ $x^{(2)}(i) = d^{(0)}(3i+2)$ $x^{(3)}(i) = d^{(1)}(3i)$ $M_{\text{layer_symb}}^{\text{layer}} = M_{\text{symb}}^{(0)}/3 = M_{\text{symb}}^{(1)}/3$ $x^{(4)}(i) = d^{(1)}(3i+1)$ $x^{(5)}(i) = d^{(1)}(3i+2)$
7	2	$x^{(0)}(i) = d^{(0)}(3i)$ $x^{(1)}(i) = d^{(0)}(3i+1)$ $x^{(2)}(i) = d^{(0)}(3i+2)$ $x^{(3)}(i) = d^{(1)}(4i)$ $M_{\text{layer_symb}}^{\text{layer}} = M_{\text{symb}}^{(0)}/3 = M_{\text{symb}}^{(1)}/4$ $x^{(4)}(i) = d^{(1)}(4i+1)$ $x^{(5)}(i) = d^{(1)}(4i+2)$ $x^{(6)}(i) = d^{(1)}(4i+3)$
8	2	$x^{(0)}(i) = d^{(0)}(4i)$ $x^{(1)}(i) = d^{(0)}(4i+1)$ $x^{(2)}(i) = d^{(0)}(4i+2)$ $x^{(3)}(i) = d^{(0)}(4i+3)$ $x^{(4)}(i) = d^{(1)}(4i)$ $M_{\text{layer_symb}}^{\text{layer}} = M_{\text{symb}}^{(0)}/4 = M_{\text{symb}}^{(1)}/4$ $x^{(5)}(i) = d^{(1)}(4i+1)$ $x^{(6)}(i) = d^{(1)}(4i+2)$ $x^{(7)}(i) = d^{(1)}(4i+3)$

wherein in the above table, $d^{(0)}(i)$ is the modulation symbols for the first codeword, $d^{(1)}(i)$ is the modulation symbols for the second codeword, $x^{(n)}(i)$ is mapping symbols mapped to layer n , $M_{\text{symb}}^{(0)}$ is a number of modulation symbols for the first codeword and $M_{\text{symb}}^{(1)}$ is a number of modulation symbols for the second codeword.

7. A method of receiving data in a multiple antenna system, the method comprising:

receiving mapping symbols which are mapped to a plurality of layers;
demapping the mapping symbols to generate modulation symbols for a first codeword and modulation symbols for a second codeword,

characterized in that when a number of the plurality of layers is larger than 4, at least one of the modulation symbols for the first codeword and the modulation symbols for the second codeword is mapped to at least 3 layers, wherein when the number of the plurality of layers is 5, the modulation symbols for the first codeword are mapped to 2 layers and the modulation symbols for the second codeword are mapped to remaining 3 layers, and when the number of the plurality of layers is 6, the modulation symbols for the first codeword are mapped to 3 layers and the modulation symbols for the second codeword are mapped to remaining 3 layers, and when the number of the plurality of layers is 7, the modulation symbols for the first codeword are mapped to 3 layers and the modulation symbols for the second codeword are mapped to remaining 4 layers, and when the number of the plurality of layers is 8, the modulation symbols for the first codeword are mapped to 4 layers and the modulation symbols for the second codeword are mapped to remaining 4 layers.

8. The method of claim 7, wherein when the number of the plurality of layers is 5, 6, 7 or 8, the mapping symbols are demapped to the modulation symbols for the first codeword and the modulation symbols for the second codeword according to the following table:

Number of the plurality of layers	Number of codewords	Codeword-to-layer mapping $i = 0, 1, \dots, M_{\text{layer}}^{\text{layer}} - 1$, $M_{\text{symb}}^{\text{layer}}$: a number of modulation symbols for each layer of the plurality of layers
5	2	$x^{(0)}(i) = d^{(0)}(2i)$ $x^{(1)}(i) = d^{(0)}(2i+1)$ $x^{(2)}(i) = d^{(1)}(3i)$ $M_{\text{symb}}^{\text{layer}} = M_{\text{symb}}^{(0)}/2 = M_{\text{symb}}^{(1)}/3$ $x^{(3)}(i) = d^{(1)}(3i+1)$ $x^{(4)}(i) = d^{(1)}(3i+2)$
6	2	$x^{(0)}(i) = d^{(0)}(3i)$ $x^{(1)}(i) = d^{(0)}(3i+1)$ $x^{(2)}(i) = d^{(0)}(3i+2)$ $x^{(3)}(i) = d^{(1)}(3i)$ $M_{\text{symb}}^{\text{layer}} = M_{\text{symb}}^{(0)}/3 = M_{\text{symb}}^{(1)}/3$ $x^{(4)}(i) = d^{(1)}(3i+1)$ $x^{(5)}(i) = d^{(1)}(3i+2)$
7	2	$x^{(0)}(i) = d^{(0)}(3i)$ $x^{(1)}(i) = d^{(0)}(3i+1)$ $x^{(2)}(i) = d^{(0)}(3i+2)$ $x^{(3)}(i) = d^{(1)}(4i)$ $M_{\text{symb}}^{\text{layer}} = M_{\text{symb}}^{(0)}/3 = M_{\text{symb}}^{(1)}/4$ $x^{(4)}(i) = d^{(1)}(4i+1)$ $x^{(5)}(i) = d^{(1)}(4i+2)$ $x^{(6)}(i) = d^{(1)}(4i+3)$
8	2	$x^{(0)}(i) = d^{(0)}(4i)$ $x^{(1)}(i) = d^{(0)}(4i+1)$ $x^{(2)}(i) = d^{(0)}(4i+2)$ $x^{(3)}(i) = d^{(0)}(4i+3)$ $x^{(4)}(i) = d^{(1)}(4i)$ $M_{\text{symb}}^{\text{layer}} = M_{\text{symb}}^{(0)}/4 = M_{\text{symb}}^{(1)}/4$ $x^{(5)}(i) = d^{(1)}(4i+1)$ $x^{(6)}(i) = d^{(1)}(4i+2)$ $x^{(7)}(i) = d^{(1)}(4i+3)$

wherein, in the above table, $d^{(0)}(i)$ is the modulation symbols for the first codeword, $d^{(1)}(i)$ is the modulation symbols for the second codeword, $x^{(n)}(i)$ is mapping symbols mapped to layer n , $M_{\text{symb}}^{(0)}$ is a number of modulation symbols for the first codeword and $M_{\text{symb}}^{(1)}$ is a number of modulation symbols for the second codeword.

9. A receiver, the receiver comprising:

- a radio frequency, RF, unit for transmitting and receiving a radio signal; and
- a processor coupled to the RF unit,

wherein the processor receives mapping symbols which are mapped to a plurality of layers and demaps the mapping symbols to generate modulation symbols for a first codeword and modulation symbols for a second codeword, **characterized in that** when a number of the plurality of layers is larger than 4, at least one of the modulation symbols for first codeword and the modulation symbols for the second codeword is mapped to at least 3 layers and, wherein when the number of the plurality of layers is 5, the modulation symbols for the first codeword are mapped to 2 layers and the modulation symbols for the second codeword are mapped to remaining 3 layers, and when the number of the plurality of layers is 6, the modulation symbols for the first codeword are mapped to 3 layers and the modulation symbols for the second codeword are mapped to remaining 3 layers, and when the number of the plurality of layers is 7, the modulation symbols for the first codeword are mapped to 3 layers

and the modulation symbols for the second codeword are mapped to remaining 4 layers, and when the number of the plurality of layers is 8, the modulation symbols for the first codeword are mapped to 4 layers and the modulation symbols for the second codeword are mapped to remaining 4 layers.

10. The receiver of claim 9, wherein when the number of the plurality of layers is 5, 6, 7, or 8, the mapping symbols are demapped to the modulation symbols for the first codeword and the modulation symbols for the second codeword according to the following table:

Number of the plurality of layers	Number of codewords	Codeword-to-layer mapping $i = 0, 1, \dots, M^{\text{layer}}_{\text{symb}} - 1$, $M^{\text{layer}}_{\text{symb}}$: a number of modulation symbols for each layer of the plurality of layers
5	2	$x^{(0)}(i) = d^{(0)}(2i)$ $x^{(1)}(i) = d^{(0)}(2i+1)$ $x^{(2)}(i) = d^{(1)}(3i) \quad M^{\text{layer}}_{\text{symb}} = M^{(0)}_{\text{symb}}/2 = M^{(1)}_{\text{symb}}/3$ $x^{(3)}(i) = d^{(1)}(3i+1)$ $x^{(4)}(i) = d^{(1)}(3i+2)$
6	2	$x^{(0)}(i) = d^{(0)}(3i)$ $x^{(1)}(i) = d^{(0)}(3i+1)$ $x^{(2)}(i) = d^{(0)}(3i+2)$ $x^{(3)}(i) = d^{(1)}(3i) \quad M^{\text{layer}}_{\text{symb}} = M^{(0)}_{\text{symb}}/3 = M^{(1)}_{\text{symb}}/3$ $x^{(4)}(i) = d^{(1)}(3i+1)$ $x^{(5)}(i) = d^{(1)}(3i+2)$
7	2	$x^{(0)}(i) = d^{(0)}(3i)$ $x^{(1)}(i) = d^{(0)}(3i+1)$ $x^{(2)}(i) = d^{(0)}(3i+2)$ $x^{(3)}(i) = d^{(1)}(4i) \quad M^{\text{layer}}_{\text{symb}} = M^{(0)}_{\text{symb}}/3 = M^{(1)}_{\text{symb}}/4$ $x^{(4)}(i) = d^{(1)}(4i+1)$ $x^{(5)}(i) = d^{(1)}(4i+2)$ $x^{(6)}(i) = d^{(1)}(4i+3)$
8	2	$x^{(0)}(i) = d^{(0)}(4i)$ $x^{(1)}(i) = d^{(0)}(4i+1)$ $x^{(2)}(i) = d^{(0)}(4i+2)$ $x^{(3)}(i) = d^{(0)}(4i+3)$ $x^{(4)}(i) = d^{(1)}(4i) \quad M^{\text{layer}}_{\text{symb}} = M^{(0)}_{\text{symb}}/4 = M^{(1)}_{\text{symb}}/4$ $x^{(5)}(i) = d^{(1)}(4i+1)$ $x^{(6)}(i) = d^{(1)}(4i+2)$ $x^{(7)}(i) = d^{(1)}(4i+3)$

wherein, in the above table, $d^{(0)}(i)$ is the modulation symbols for the first codeword, $d^{(1)}(i)$ is the modulation symbols for the second codeword, $x^{(n)}(i)$ is mapping symbols mapped to layer n , $M^{(0)}_{\text{symb}}$ is a number of modulation symbols for the first codeword and $M^{(1)}_{\text{symb}}$ is a number of modulation symbols for the second codeword.

Patentansprüche

1. Verfahren zur Datenübertragung in einem Mehrantennensystem, wobei das Verfahren umfasst:

Erzeugen von Zuordnungssymbolen durch Zuordnen von Modulationssymbolen für ein erstes Codewort und Modulationssymbolen für ein zweites Codewort zu mehreren Schichten; und Übertragen der Zuordnungssymbole durch mehrere Antennen,

dadurch gekennzeichnet, dass

EP 2 263 328 B1

wenn eine Anzahl der mehreren Schichten größer als 4 ist, wenigstens eines der Modulationssymbole für das erste Codewort und der Modulationssymbole für das zweite Codewort wenigstens 3 Schichten zugeordnet wird, wobei, wenn die Anzahl der mehreren Schichten 5 beträgt, die Modulationssymbole für das erste Codewort 2 Schichten zugeordnet werden und die Modulationssymbole für das zweite Codewort den verbleibenden 3 Schichten zugeordnet werden und

wenn die Anzahl der mehreren Schichten 6 beträgt, die Modulationssymbole für das erste Codewort 3 Schichten zugeordnet werden und die Modulationssymbole für das zweite Codewort den verbleibenden 3 Schichten zugeordnet werden und

wenn die Anzahl der mehreren Schichten 7 beträgt, die Modulationssymbole für das erste Codewort 3 Schichten zugeordnet werden und die Modulationssymbole für das zweite Codewort den verbleibenden 4 Schichten zugeordnet werden und

wenn die Anzahl der mehreren Schichten 8 beträgt, die Modulationssymbole für das erste Codewort 4 Schichten zugeordnet werden und die Modulationssymbole für das zweite Codewort den verbleibenden 4 Schichten zugeordnet werden.

2. Verfahren nach Anspruch 1, wobei die Anzahl der mehreren Schichten kleiner als oder gleich eine(r) Anzahl der mehreren Antennen ist.

3. Verfahren nach Anspruch 1, weiterhin umfassend: Bestimmen der Anzahl der mehreren Schichten.

4. Verfahren nach Anspruch 1, wobei, wenn die Anzahl der mehreren Schichten 5, 6, 7 oder 8 beträgt, die Modulationssymbole für das erste Codewort und die Modulationssymbole für das zweite Codewort den Schichten gemäß der folgenden Tabelle zugeordnet werden:

Anzahl der mehreren Schichten	Anzahl an Codewörtern	Codewort-Schicht-Zuordnung $i = 0, 1, \dots, M_{\text{layer_symb}} - 1$, $M_{\text{layer_symb}}$: eine Anzahl an Modulationssymbolen für jede Schicht der mehreren Schichten
5	2	$x^{(0)}(i) = d^{(0)}(2i)$ $x^{(1)}(i) = d^{(0)}(2i+1)$ $x^{(2)}(i) = d^{(1)}(3i)$ $M_{\text{layer_symb}} = M^{(0)}_{\text{symb}}/2 = M^{(1)}_{\text{symb}}/3$ $x^{(3)}(i) = d^{(1)}(3i+1)$ $x^{(4)}(i) = d^{(1)}(3i+2)$
6	2	$x^{(0)}(i) = d^{(0)}(3i)$ $x^{(1)}(i) = d^{(0)}(3i+1)$ $x^{(2)}(i) = d^{(0)}(3i+2)$ $x^{(3)}(i) = d^{(1)}(3i)$ $M_{\text{layer_symb}} = M^{(0)}_{\text{symb}}/3 = M^{(1)}_{\text{symb}}/3$ $x^{(4)}(i) = d^{(1)}(3i+1)$ $x^{(5)}(i) = d^{(1)}(3i+2)$
7	2	$x^{(0)}(i) = d^{(0)}(3i)$ $x^{(1)}(i) = d^{(0)}(3i+1)$ $x^{(2)}(i) = d^{(0)}(3i+2)$ $x^{(3)}(i) = d^{(1)}(4i)$ $M_{\text{layer_symb}} = M^{(0)}_{\text{symb}}/3 = M^{(1)}_{\text{symb}}/4$ $x^{(4)}(i) = d^{(1)}(4i+1)$ $x^{(5)}(i) = d^{(1)}(4i+2)$ $x^{(6)}(i) = d^{(1)}(4i+3)$
8	2	$x^{(0)}(i) = d^{(0)}(4i)$ $x^{(1)}(i) = d^{(0)}(4i+1)$ $x^{(2)}(i) = d^{(0)}(4i+2)$ $x^{(3)}(i) = d^{(0)}(4i+3)$ $x^{(4)}(i) = d^{(1)}(4i)$ $M_{\text{layer_symb}} = M^{(0)}_{\text{symb}}/4 = M^{(1)}_{\text{symb}}/4$ $x^{(5)}(i) = d^{(1)}(4i+1)$

(fortgesetzt)

Anzahl der mehreren Schichten	Anzahl an Codewörtern	Codewort-Schicht-Zuordnung $i = 0, 1, \dots, M^{\text{layer}}_{\text{symb}} - 1$, $M^{\text{layer}}_{\text{symb}}$: eine Anzahl an Modulationssymbolen für jede Schicht der mehreren Schichten
		$x^{(6)}(i) = d^{(1)}(4i+2)$ $x^{(7)}(i) = d^{(1)}(4i+3)$

wobei in der vorstehenden Tabelle $d^{(0)}(i)$ die Modulationssymbole für das erste Codewort sind, $d^{(1)}(i)$ die Modulationssymbole für das zweite Codewort sind, $x^{(n)}(i)$ einer Schicht n zugeordnete Zuordnungssymbole sind, $M^{(0)}_{\text{symb}}$ eine Anzahl an Modulationssymbolen für das erste Codewort ist und $M^{(1)}_{\text{symb}}$ eine Anzahl an Modulationssymbolen für das zweite Codewort ist.

5. Sender (900), umfassend:

eine Funkfrequenzeinheit, RF-Einheit, (920) zum Senden und Empfangen eines Funksignals; und einen Prozessor (910), der mit der RF-Einheit gekoppelt ist,

wobei der Prozessor (910) durch Zuordnen von Modulationssymbolen für ein erstes Codewort und Modulationssymbolen für ein zweites Codewort zu mehreren Schichten Zuordnungssymbole erzeugt und die Zuordnungssymbole überträgt,

dadurch gekennzeichnet, dass

wenn eine Anzahl der mehreren Schichten größer als 4 ist, wenigstens eines der Modulationssymbole für das erste Codewort und der Modulationssymbole für das zweite Codewort wenigstens 3 Schichten zugeordnet wird und wobei, wenn die Anzahl der mehreren Schichten 5 beträgt, die Modulationssymbole für das erste Codewort 2 Schichten zugeordnet werden und die Modulationssymbole für das zweite Codewort den verbleibenden 3 Schichten zugeordnet werden und

wenn die Anzahl der mehreren Schichten 6 beträgt, die Modulationssymbole für das erste Codewort 3 Schichten zugeordnet werden und die Modulationssymbole für das zweite Codewort den verbleibenden 3 Schichten zugeordnet werden und

wenn die Anzahl der mehreren Schichten 7 beträgt, die Modulationssymbole für das erste Codewort 3 Schichten zugeordnet werden und die Modulationssymbole für das zweite Codewort den verbleibenden 4 Schichten zugeordnet werden und

wenn die Anzahl der mehreren Schichten 8 beträgt, die Modulationssymbole für das erste Codewort 4 Schichten zugeordnet werden und die Modulationssymbole für das zweite Codewort den verbleibenden 4 Schichten zugeordnet werden.

6. Sender (900) nach Anspruch 5,

wobei, wenn die Anzahl der mehreren Schichten 5, 6, 7 oder 8 beträgt, die Modulationssymbole für das erste Codewort und die Modulationssymbole für das zweite Codewort den Schichten gemäß der folgenden Tabelle zugeordnet werden:

Anzahl der mehreren Schichten	Anzahl an Codewörtern	Codewort-Schicht-Zuordnung $i = 0, 1, \dots, M^{\text{layer}}_{\text{symb}} - 1$, $M^{\text{layer}}_{\text{symb}}$: eine Anzahl an Modulationssymbolen für jede Schicht der mehreren Schichten
5	2	$x^{(0)}(i) = d^{(0)}(2i)$ $x^{(1)}(i) = d^{(0)}(2i+1)$ $x^{(2)}(i) = d^{(1)}(3i)$ $M^{\text{layer}}_{\text{symb}} = M^{(0)}_{\text{symb}} = M^{(1)}_{\text{symb}}/3$ $x^{(3)}(i) = d^{(1)}(3i+1)$ $x^{(4)}(i) = d^{(1)}(3i+2)$
6	2	$x^{(0)}(i) = d^{(0)}(3i)$ $x^{(1)}(i) = d^{(0)}(3i+1)$ $x^{(2)}(i) = d^{(0)}(3i+2)$

(fortgesetzt)

5	Anzahl der mehreren Schichten	Anzahl an Codewörtern	Codewort-Schicht-Zuordnung $i = 0, 1, \dots, M^{\text{layer}}_{\text{symb}} - 1,$ $M^{\text{layer}}_{\text{symb}}$: eine Anzahl an Modulationssymbolen für jede Schicht der mehreren Schichten
10			$x^{(3)}(i) = d^{(1)}(3i)$ $M^{\text{layer}}_{\text{symb}} = M^{(0)}_{\text{symb}}/3 = M^{(1)}_{\text{symb}}/3$ $x^{(4)}(i) = d^{(1)}(3i+1)$ $x^{(5)}(i) = d^{(1)}(3i+2)$
15	7	2	$x^{(0)}(i) = d^{(0)}(3i)$ $x^{(1)}(i) = d^{(0)}(3i+1)$ $x^{(2)}(i) = d^{(0)}(3i+2)$ $x^{(3)}(i) = d^{(1)}(4i)$ $M^{\text{layer}}_{\text{symb}} = M^{(0)}_{\text{symb}}/3 = M^{(1)}_{\text{symb}}/4$ $x^{(4)}(i) = d^{(1)}(4i+1)$ $x^{(5)}(i) = d^{(1)}(4i+2)$ $x^{(6)}(i) = d^{(1)}(4i+3)$
20	8	2	$x^{(0)}(i) = d^{(0)}(4i)$ $x^{(1)}(i) = d^{(0)}(4i+1)$ $x^{(2)}(i) = d^{(0)}(4i+2)$ $x^{(3)}(i) = d^{(0)}(4i+3)$ $x^{(4)}(i) = d^{(1)}(4i)$ $M^{\text{layer}}_{\text{symb}} = M^{(0)}_{\text{symb}}/4 = M^{(1)}_{\text{symb}}/4$ $x^{(5)}(i) = d^{(1)}(4i+1)$ $x^{(6)}(i) = d^{(1)}(4i+2)$ $x^{(7)}(i) = d^{(1)}(4i+3)$
25			

wobei in der vorstehenden Tabelle $d^{(0)}(i)$ die Modulationssymbole für das erste Codewort sind, $d^{(1)}(i)$ die Modulationssymbole für das zweite Codewort sind, $x^{(n)}(i)$ einer Schicht n zugeordnete Zuordnungssymbole sind, $M^{(0)}_{\text{symb}}$ eine Anzahl an Modulationssymbolen für das erste Codewort ist und $M^{(1)}_{\text{symb}}$ eine Anzahl an Modulationssymbolen für das zweite Codewort ist.

7. Verfahren zum Empfangen von Daten in einem Mehrantennensystem, wobei das Verfahren umfasst:

Empfangen von Zuordnungssymbolen, die mehreren Schichten zugeordnet sind;
 Aufheben der Zuordnung der Zuordnungssymbole, um Modulationssymbole für ein erstes Codewort und Modulationssymbole für ein zweites Codewort zu erzeugen,

dadurch gekennzeichnet, dass

wenn eine Anzahl der mehreren Schichten größer als 4 ist, wenigstens eines der Modulationssymbole für das erste Codewort und der Modulationssymbole für das zweite Codewort wenigstens 3 Schichten zugeordnet wird, wobei, wenn die Anzahl der mehreren Schichten 5 beträgt, die Modulationssymbole für das erste Codewort 2 Schichten zugeordnet werden und die Modulationssymbole für das zweite Codewort den verbleibenden 3 Schichten zugeordnet werden und
 wenn die Anzahl der mehreren Schichten 6 beträgt, die Modulationssymbole für das erste Codewort 3 Schichten zugeordnet werden und die Modulationssymbole für das zweite Codewort den verbleibenden 3 Schichten zugeordnet werden und
 wenn die Anzahl der mehreren Schichten 7 beträgt, die Modulationssymbole für das erste Codewort 3 Schichten zugeordnet werden und die Modulationssymbole für das zweite Codewort den verbleibenden 4 Schichten zugeordnet werden und
 wenn die Anzahl der mehreren Schichten 8 beträgt, die Modulationssymbole für das erste Codewort 4 Schichten zugeordnet werden und die Modulationssymbole für das zweite Codewort den verbleibenden 4 Schichten zugeordnet werden.

8. Verfahren nach Anspruch 7, wobei, wenn die Anzahl der mehreren Schichten 5, 6, 7 oder 8 beträgt, die Zuordnung der Zuordnungssymbole gemäß der folgenden Tabelle aufgehoben wird, um die Modulationssymbole für das erste Codewort und die Modulationssymbole für das zweite Codewort zu erhalten:

Anzahl der mehreren Schichten	Anzahl an Codewörtern	Codewort-Schicht-Zuordnung $i = 0, 1, \dots, M_{\text{symb}}^{\text{layer}} - 1$, $M_{\text{symb}}^{\text{layer}}$: eine Anzahl an Modulationssymbolen für jede Schicht der mehreren Schichten
5	2	$x^{(0)}(i) = d^{(0)}(2i)$ $x^{(1)}(i) = d^{(0)}(2i+1)$ $x^{(2)}(i) = d^{(1)}(3i)$ $M_{\text{symb}}^{\text{layer}} = M_{\text{symb}}^{(0)}/2 = M_{\text{symb}}^{(1)}/3$ $x^{(3)}(i) = d^{(1)}(3i+1)$ $x^{(4)}(i) = d^{(1)}(3i+2)$
6	2	$x^{(0)}(i) = d^{(0)}(3i)$ $x^{(1)}(i) = d^{(0)}(3i+1)$ $x^{(2)}(i) = d^{(0)}(3i+2)$ $x^{(3)}(i) = d^{(1)}(3i)$ $M_{\text{symb}}^{\text{layer}} = M_{\text{symb}}^{(0)}/3 = M_{\text{symb}}^{(1)}/3$ $x^{(4)}(i) = d^{(1)}(3i+1)$ $x^{(5)}(i) = d^{(1)}(3i+2)$
7	2	$x^{(0)}(i) = d^{(0)}(3i)$ $x^{(1)}(i) = d^{(0)}(3i+1)$ $x^{(2)}(i) = d^{(0)}(3i+2)$ $x^{(3)}(i) = d^{(1)}(4i)$ $M_{\text{symb}}^{\text{layer}} = M_{\text{symb}}^{(0)}/3 = M_{\text{symb}}^{(1)}/4$ $x^{(4)}(i) = d^{(1)}(4i+1)$ $x^{(5)}(i) = d^{(1)}(4i+2)$ $x^{(6)}(i) = d^{(1)}(4i+3)$
8	2	$x^{(0)}(i) = d^{(0)}(4i)$ $x^{(1)}(i) = d^{(0)}(4i+1)$ $x^{(2)}(i) = d^{(0)}(4i+2)$ $x^{(3)}(i) = d^{(0)}(4i+3)$ $x^{(4)}(i) = d^{(1)}(4i)$ $M_{\text{symb}}^{\text{layer}} = M_{\text{symb}}^{(0)}/4 = M_{\text{symb}}^{(1)}/4$ $x^{(5)}(i) = d^{(1)}(4i+1)$ $x^{(6)}(i) = d^{(1)}(4i+2)$ $x^{(7)}(i) = d^{(1)}(4i+3)$

wobei in der vorstehenden Tabelle $d^{(0)}(i)$ die Modulationssymbole für das erste Codewort sind, $d^{(1)}(i)$ die Modulationssymbole für das zweite Codewort sind, $x^{(n)}(i)$ einer Schicht n zugeordnete Zuordnungssymbole sind, $M_{\text{symb}}^{(0)}$ eine Anzahl an Modulationssymbolen für das erste Codewort ist und $M_{\text{symb}}^{(1)}$ eine Anzahl an Modulationssymbolen für das zweite Codewort ist.

9. Empfänger, wobei der Empfänger umfasst:
 eine Funkfrequenzeinheit, RF-Einheit, zum Senden und Empfangen eines Funksignals; und
 einen Prozessor, der mit der RF-Einheit gekoppelt ist,

wobei der Prozessor Zuordnungssymbole empfängt, die mehreren Schichten zugeordnet sind, und die Zuordnung der Zuordnungssymbole aufhebt, um Modulationssymbole für ein erstes Codewort und Modulationssymbole für ein zweites Codewort zu erzeugen,

dadurch gekennzeichnet, dass
 wenn eine Anzahl der mehreren Schichten größer als 4 ist, wenigstens eines der Modulationssymbole für das erste Codewort und der Modulationssymbole für das zweite Codewort wenigstens 3 Schichten zugeordnet wird und wobei, wenn die Anzahl der mehreren Schichten 5 beträgt, die Modulationssymbole für das erste Codewort 2 Schichten zugeordnet werden und die Modulationssymbole für das zweite Codewort den verbleibenden 3 Schichten zugeordnet werden und
 wenn die Anzahl der mehreren Schichten 6 beträgt, die Modulationssymbole für das erste Codewort 3 Schichten zugeordnet werden und die Modulationssymbole für das zweite Codewort den verbleibenden 3 Schichten zugeordnet

EP 2 263 328 B1

werden und

wenn die Anzahl der mehreren Schichten 7 beträgt, die Modulationssymbole für das erste Codewort 3 Schichten zugeordnet werden und die Modulationssymbole für das zweite Codewort den verbleibenden 4 Schichten zugeordnet werden und

5 wenn die Anzahl der mehreren Schichten 8 beträgt, die Modulationssymbole für das erste Codewort 4 Schichten zugeordnet werden und die Modulationssymbole für das zweite Codewort den verbleibenden 4 Schichten zugeordnet werden.

10 Empfänger nach Anspruch 9, wobei, wenn die Anzahl der mehreren Schichten 5, 6, 7 oder 8 beträgt, die Zuordnung der Zuordnungssymbole gemäß der folgenden Tabelle aufgehoben wird, um die Modulationssymbole für das erste Codewort und die Modulationssymbole für das zweite Codewort zu erhalten:

Anzahl der mehreren Schichten	Anzahl an Codewörtern	Codewort-Schicht-Zuordnung $i = 0, 1, \dots, M^{\text{layer}}_{\text{symb}} - 1$, $M^{\text{layer}}_{\text{symb}}$: eine Anzahl an Modulationssymbolen für jede Schicht der mehreren Schichten
5	2	$x^{(0)}(i) = d^{(0)}(2i)$ $x^{(1)}(i) = d^{(0)}(2i+1)$ $x^{(2)}(i) = d^{(1)}(3i)$ $M^{\text{layer}}_{\text{symb}} = M^{(0)}_{\text{symb}}/2 = M^{(1)}_{\text{symb}}/3$ $x^{(3)}(i) = d^{(1)}(3i+1)$ $x^{(4)}(i) = d^{(1)}(3i+2)$
6	2	$x^{(0)}(i) = d^{(0)}(3i)$ $x^{(1)}(i) = d^{(0)}(3i+1)$ $x^{(2)}(i) = d^{(0)}(3i+2)$ $x^{(3)}(i) = d^{(1)}(3i)$ $M^{\text{layer}}_{\text{symb}} = M^{(0)}_{\text{symb}}/3 = M^{(1)}_{\text{symb}}/3$ $x^{(4)}(i) = d^{(1)}(3i+1)$ $x^{(5)}(i) = d^{(1)}(3i+2)$
7	2	$x^{(0)}(i) = d^{(0)}(3i)$ $x^{(1)}(i) = d^{(0)}(3i+1)$ $x^{(2)}(i) = d^{(0)}(3i+2)$ $x^{(3)}(i) = d^{(1)}(4i)$ $M^{\text{layer}}_{\text{symb}} = M^{(0)}_{\text{symb}}/3 = M^{(1)}_{\text{symb}}/4$ $x^{(4)}(i) = d^{(1)}(4i+1)$ $x^{(5)}(i) = d^{(1)}(4i+2)$ $x^{(6)}(i) = d^{(1)}(4i+3)$
8	2	$x^{(0)}(i) = d^{(0)}(4i)$ $x^{(1)}(i) = d^{(0)}(4i+1)$ $x^{(2)}(i) = d^{(0)}(4i+2)$ $x^{(3)}(i) = d^{(0)}(4i+3)$ $x^{(4)}(i) = d^{(1)}(4i)$ $M^{\text{layer}}_{\text{symb}} = M^{(0)}_{\text{symb}}/4 = M^{(1)}_{\text{symb}}/4$ $x^{(5)}(i) = d^{(1)}(4i+1)$ $x^{(6)}(i) = d^{(1)}(4i+2)$ $x^{(7)}(i) = d^{(1)}(4i+3)$

wobei in der vorstehenden Tabelle $d^{(0)}(i)$ die Modulationssymbole für das erste Codewort sind, $d^{(1)}(i)$ die Modulationssymbole für das zweite Codewort sind, $x^{(n)}(i)$ einer Schicht n zugeordnete Zuordnungssymbole sind, $M^{(0)}_{\text{symb}}$ eine Anzahl an Modulationssymbolen für das erste Codewort ist und $M^{(1)}_{\text{symb}}$ eine Anzahl an Modulationssymbolen für das zweite Codewort ist.

55 **Revendications**

1. Procédé de transmission de données dans un système à antennes multiples, le procédé comprenant :

EP 2 263 328 B1

générer des symboles de mappage en mappant des symboles de modulation pour un premier mot de code et des symboles de modulation pour un deuxième mot de code sur une pluralité de couches ; et émettre les symboles de mappage par l'intermédiaire d'une pluralité d'antennes,

5 **caractérisé en ce que** lorsqu'un nombre de couches dans la pluralité de couches est supérieur à 4, au moins l'un des symboles de modulation pour le premier mot de code et des symboles de modulation pour le deuxième mot de code est mappé sur au moins 3 couches, dans lequel, lorsque le nombre de couches dans la pluralité de couches est 5, les symboles de modulation pour le premier mot de code sont mappés sur 2 couches et les symboles de modulation pour le deuxième mot de code sont mappés sur 3 couches restantes, et
 10 lorsque le nombre de la pluralité de couches est 6, les symboles de modulation pour le premier mot de code sont mappés sur 3 couches et les symboles de modulation pour le deuxième mot de code sont mappés sur 3 couches restantes, et
 15 lorsque le nombre de couches dans la pluralité de couches est 7, les symboles de modulation pour le premier mot de code sont mappés sur 3 couches et les symboles de modulation pour le deuxième mot de code sont mappés sur 4 couches restantes, et
 lorsque le nombre de couches dans la pluralité de couches est 8, les symboles de modulation pour le premier mot de code sont mappés sur 4 couches et les symboles de modulation pour le deuxième mot de code sont mappés sur 4 couches restantes.

- 20
2. Procédé selon la revendication 1, dans lequel le nombre de couches dans la pluralité de couches est inférieur ou égal à un nombre d'antennes dans la pluralité d'antennes.
 3. Procédé selon la revendication 1, comprenant en outre déterminer le nombre de couches dans la pluralité de couches.
 - 25 4. Procédé selon la revendication 1, dans lequel, lorsque le nombre de couches dans la pluralité de couches est 5, 6, 7 ou 8, les symboles de modulation pour le premier mot de code et les symboles de modulation pour le deuxième mot de code sont mappés sur des couches selon le tableau suivant :

30

Nombre de couches dans la pluralité de couches	Nombre de mots de code	Mappage des mots de code sur les couches $i=0, 1, \dots, M^{\text{layer}}_{\text{symb}}-1$ $M^{\text{layer}}_{\text{symb}}$: un nombre de symboles de modulation pour chaque couche de la pluralité de couches
5	2	$x^{(0)}(i)=d^{(0)}(2i)$ $x^{(1)}(i)=d^{(0)}(2i+1)$ $x^{(2)}(i)=d^{(1)}(3i)$ $x^{(3)}(i)=d^{(1)}(3i+1)$ $x^{(4)}(i)=d^{(1)}(3i+2)$ $M^{\text{layer}}_{\text{symb}}=M^{(0)}_{\text{symb}}/2=M^{(1)}_{\text{symb}}/3$
6	2	$x^{(0)}(i)=d^{(0)}(3i)$ $x^{(1)}(i)=d^{(0)}(3i+1)$ $x^{(2)}(i)=d^{(0)}(3i+2)$ $x^{(3)}(i)=d^{(1)}(3i)$ $x^{(4)}(i)=d^{(1)}(3i+1)$ $x^{(5)}(i)=d^{(1)}(3i+2)$ $M^{\text{layer}}_{\text{symb}}=M^{(0)}_{\text{symb}}/3=M^{(1)}_{\text{symb}}/3$
7	2	$x^{(0)}(i)=d^{(0)}(3i)$ $x^{(1)}(i)=d^{(0)}(3i+1)$ $x^{(2)}(i)=d^{(0)}(3i+2)$ $x^{(3)}(i)=d^{(1)}(4i)$ $x^{(4)}(i)=d^{(1)}(4i+1)$ $x^{(5)}(i)=d^{(1)}(4i+2)$ $x^{(6)}(i)=d^{(1)}(4i+3)$ $M^{\text{layer}}_{\text{symb}}=M^{(0)}_{\text{symb}}/3=M^{(1)}_{\text{symb}}/4$
8	2	$x^{(0)}(i)=d^{(0)}(4i)$ $x^{(1)}(i)=d^{(0)}(4i+1)$

35

40

45

50

55

EP 2 263 328 B1

(suite)

5	Nombre de couches dans la pluralité de couches	Nombre de mots de code	Mappage des mots de code sur les couches $i=0, 1, \dots, M^{\text{layer}}_{\text{symb}}-1$ $M^{\text{layer}}_{\text{symb}}$: un nombre de symboles de modulation pour chaque couche de la pluralité de couches
10			$x^{(2)}(i)=d^{(0)}(4i+2)$ $x^{(3)}(i)=d^{(0)}(4i+3)$ $x^{(4)}(i)=d^{(1)}(4i)$ $x^{(5)}(i)=d^{(1)}(4i+1)$ $x^{(6)}(i)=d^{(1)}(4i+2)$ $x^{(7)}(i)=d^{(1)}(4i+3)$

$$M^{\text{layer}}_{\text{symb}}=M^{(0)}_{\text{symb}}/4=M^{(1)}_{\text{symb}}/4$$

15 dans lequel, dans le tableau ci-dessus, $d^{(0)}(i)$ représente les symboles de modulation pour le premier mot de code, $d^{(1)}(i)$ représente les symboles de modulation pour le deuxième mot de code, $x^{(n)}(i)$ représente des symboles de mappage mappés sur une couche n , $M^{(0)}_{\text{symb}}$ représente un nombre de symboles de modulation pour le premier mot de code et $M^{(1)}_{\text{symb}}$ représente un nombre de symboles de modulation pour le deuxième mot de code.

20 5. Émetteur (900) comprenant :

une unité radiofréquence, RF, (920) pour émettre et recevoir un signal radio ; et un processeur (910) couplé à l'unité RF,

25 dans lequel le processeur (910) génère des symboles de mappage en mappant des symboles de modulation pour un premier mot de code et des symboles de modulation pour un deuxième mot de code sur une pluralité de couches, et transmet les symboles de mappage,

30 **caractérisé en ce que** lorsqu'un nombre de couches dans la pluralité de couches est supérieur à 4, au moins l'un des symboles de modulation pour le premier mot de code et des symboles de modulation pour le deuxième mot de code est mappé sur au moins 3 couches, et

dans lequel, lorsque le nombre de couches dans la pluralité de couches est 5, les symboles de modulation pour le premier mot de code sont mappés sur 2 couches et les symboles de modulation pour le deuxième mot de code sont mappés sur 3 couches restantes, et

35 lorsque le nombre de couches dans la pluralité de couches est 6, les symboles de modulation pour le premier mot de code sont mappés sur 3 couches et les symboles de modulation pour le deuxième mot de code sont mappés sur 3 couches restantes, et

lorsque le nombre de couches dans la pluralité de couches est 7, les symboles de modulation pour le premier mot de code sont mappés sur 3 couches et les symboles de modulation pour le deuxième mot de code sont mappés sur 4 couches restantes, et

40 lorsque le nombre de la pluralité de couches est 8, les symboles de modulation pour le premier mot de code sont mappés sur 4 couches et les symboles de modulation pour le deuxième mot de code sont mappés sur 4 couches restantes.

45 6. Émetteur (900) selon la revendication 5,

dans lequel, lorsque le nombre de couches dans la pluralité de couches est 5, 6, 7 ou 8, les symboles de modulation pour le premier mot de code et les symboles de modulation pour le deuxième mot de code sont mappés sur des couches selon le tableau suivant :

50	Nombre de couches dans la pluralité de couches	Nombre de mots de code	Mappage des mots de code sur les couches $i=0, 1, \dots, M^{\text{layer}}_{\text{symb}}-1$ $M^{\text{layer}}_{\text{symb}}$: un nombre de symboles de modulation pour chaque couche de la pluralité de couches
55	5	2	$x^{(0)}(i)=d^{(0)}(2i)$ $x^{(1)}(i)=d^{(0)}(2i+1)$ $x^{(2)}(i)=d^{(1)}(3i)$ $x^{(3)}(i)=d^{(1)}(3i+1)$

$$M^{\text{layer}}_{\text{symb}}=M^{(0)}_{\text{symb}}/2=M^{(1)}_{\text{symb}}/3$$

EP 2 263 328 B1

(suite)

Nombre de couches dans la pluralité de couches	Nombre de mots de code	Mappage des mots de code sur les couches $i=0, 1, \dots, M^{\text{layer}}_{\text{symb}}-1$ $M^{\text{layer}}_{\text{symb}}$: un nombre de symboles de modulation pour chaque couche de la pluralité de couches
		$x^{(4)}(i)=d^{(1)}(3i+2)$
6	2	$x^{(0)}(i)=d^{(0)}(3i)$ $x^{(1)}(i)=d^{(0)}(3i+1)$ $x^{(2)}(i)=d^{(0)}(3i+2)$ $x^{(3)}(i)=d^{(1)}(3i)$ $x^{(4)}(i)=d^{(1)}(3i+1)$ $x^{(5)}(i)=d^{(1)}(3i+2)$ $M^{\text{layer}}_{\text{symb}}=M^{(0)}_{\text{symb}}/3=M^{(1)}_{\text{symb}}/3$
7	2	$x^{(0)}(i)=d^{(0)}(3i)$ $x^{(1)}(i)=d^{(0)}(3i+1)$ $x^{(2)}(i)=d^{(0)}(3i+2)$ $x^{(3)}(i)=d^{(1)}(4i)$ $x^{(4)}(i)=d^{(1)}(4i+1)$ $x^{(5)}(i)=d^{(1)}(4i+2)$ $x^{(6)}(i)=d^{(1)}(4i+3)$ $M^{\text{layer}}_{\text{symb}}=M^{(0)}_{\text{symb}}/3=M^{(1)}_{\text{symb}}/4$
8	2	$x^{(0)}(i)=d^{(0)}(4i)$ $x^{(1)}(i)=d^{(0)}(4i+1)$ $x^{(2)}(i)=d^{(0)}(4i+2)$ $x^{(3)}(i)=d^{(0)}(4i+3)$ $x^{(4)}(i)=d^{(1)}(4i)$ $x^{(5)}(i)=d^{(1)}(4i+1)$ $x^{(6)}(i)=d^{(1)}(4i+2)$ $x^{(7)}(i)=d^{(1)}(4i+3)$ $M^{\text{layer}}_{\text{symb}}=M^{(0)}_{\text{symb}}/4=M^{(1)}_{\text{symb}}/4$

dans lequel, dans le tableau ci-dessus, $d^{(0)}(i)$ représente les symboles de modulation pour le premier mot de code, $d^{(1)}(i)$ représente les symboles de modulation pour le deuxième mot de code, $x^{(n)}(i)$ représente des symboles de mappage mappés sur une couche n , $M^{(0)}_{\text{symb}}$ représente un nombre de symboles de modulation pour le premier mot de code et $M^{(1)}_{\text{symb}}$ représente un nombre de symboles de modulation pour le deuxième mot de code.

7. Procédé de réception de données dans un système à antennes multiples, le procédé comprenant :

recevoir des symboles de mappage qui sont mappés sur une pluralité de couches ;
démapper des symboles de mappage pour générer des symboles de modulation pour un premier mot de code et des symboles de modulation pour un deuxième mot de code,

caractérisé en ce que lorsqu'un nombre de couches dans la pluralité de couches est supérieur à 4, au moins l'un des symboles de modulation pour le premier mot de code et des symboles de modulation pour le deuxième mot de code est mappé sur au moins 3 couches,
dans lequel, lorsque le nombre de couches dans la pluralité de couches est 5, les symboles de modulation pour le premier mot de code sont mappés sur 2 couches et les symboles de modulation pour le deuxième mot de code sont mappés sur 3 couches restantes, et
lorsque le nombre de couches dans la pluralité de couches est 6, les symboles de modulation pour le premier mot de code sont mappés sur 3 couches et les symboles de modulation pour le deuxième mot de code sont mappés sur 3 couches restantes, et
lorsque le nombre de couches dans la pluralité de couches est 7, les symboles de modulation pour le premier mot de code sont mappés sur 3 couches et les symboles de modulation pour le deuxième mot de code sont mappés sur 4 couches restantes, et
lorsque le nombre de couches dans la pluralité de couches est 8, les symboles de modulation pour le premier mot de code sont mappés sur 4 couches et les symboles de modulation pour le deuxième mot de code sont mappés

sur 4 couches restantes.

8. Procédé selon la revendication 7, dans lequel, lorsque le nombre de couches dans la pluralité de couches est 5, 6, 7 ou 8, les symboles de mappage sont démappés en symboles de modulation pour le premier mot de code et en symboles de modulation pour le deuxième mot de code selon le tableau suivant :

5
10
15
20
25
30
35
40

Nombre de couches dans la pluralité de couches	Nombre de mots de code	Mappage des mots de code sur les couches $i=0, 1, \dots, M^{\text{layer}}_{\text{symb}}-1$ $M^{\text{layer}}_{\text{symb}}$: un nombre de symboles de modulation pour chaque couche de la pluralité de couches
5	2	$x^{(0)}(i)=d^{(0)}(2i)$ $x^{(1)}(i)=d^{(0)}(2i+1)$ $x^{(2)}(i)=d^{(1)}(3i)$ $x^{(3)}(i)=d^{(1)}(3i+1)$ $x^{(4)}(i)=d^{(1)}(3i+2)$ $M^{\text{layer}}_{\text{symb}}=M^{(0)}_{\text{symb}}/2=M^{(1)}_{\text{symb}}/3$
6	2	$x^{(0)}(i)=d^{(0)}(3i)$ $x^{(1)}(i)=d^{(0)}(3i+1)$ $x^{(2)}(i)=d^{(0)}(3i+2)$ $x^{(3)}(i)=d^{(1)}(3i)$ $x^{(4)}(i)=d^{(1)}(3i+1)$ $x^{(5)}(i)=d^{(1)}(3i+2)$ $M^{\text{layer}}_{\text{symb}}=M^{(0)}_{\text{symb}}/3=M^{(1)}_{\text{symb}}/3$
7	2	$x^{(0)}(i)=d^{(0)}(3i)$ $x^{(1)}(i)=d^{(0)}(3i+1)$ $x^{(2)}(i)=d^{(0)}(3i+2)$ $x^{(3)}(i)=d^{(1)}(4i)$ $x^{(4)}(i)=d^{(1)}(4i+1)$ $x^{(5)}(i)=d^{(1)}(4i+2)$ $x^{(6)}(i)=d^{(1)}(4i+3)$ $M^{\text{layer}}_{\text{symb}}=M^{(0)}_{\text{symb}}/3=M^{(1)}_{\text{symb}}/4$
8	2	$x^{(0)}(i)=d^{(0)}(4i)$ $x^{(1)}(i)=d^{(0)}(4i+1)$ $x^{(2)}(i)=d^{(0)}(4i+2)$ $x^{(3)}(i)=d^{(0)}(4i+3)$ $x^{(4)}(i)=d^{(1)}(4i)$ $x^{(5)}(i)=d^{(1)}(4i+1)$ $x^{(6)}(i)=d^{(1)}(4i+2)$ $x^{(7)}(i)=d^{(1)}(4i+3)$ $M^{\text{layer}}_{\text{symb}}=M^{(0)}_{\text{symb}}/4=M^{(1)}_{\text{symb}}/4$

dans lequel, dans le tableau ci-dessus, $d^{(0)}(i)$ représente les symboles de modulation pour le premier mot de code, $d^{(1)}(i)$ représente les symboles de modulation pour le deuxième mot de code, $x^{(n)}(i)$ représente des symboles de mappage mappés sur une couche n , $M^{(0)}_{\text{symb}}$ représente un nombre de symboles de modulation pour le premier mot de code et $M^{(1)}_{\text{symb}}$ représente un nombre de symboles de modulation pour le deuxième mot de code.

9. Récepteur, le récepteur comprenant :

une unité radiofréquence, RF, pour émettre et recevoir un signal radio ; et
un processeur couplé à l'unité RF,

dans lequel le processeur reçoit des symboles de mappage qui sont mappés sur une pluralité de couches et démappe les symboles de mappage pour générer des symboles de modulation pour un premier mot de code et des symboles de modulation pour un deuxième mot de code,

caractérisé en ce que lorsqu'un nombre de couches dans la pluralité de couches est supérieur à 4, au moins l'un des symboles de modulation pour le premier mot de code et des symboles de modulation pour le deuxième mot de code est mappé sur au moins 3 couches, et

EP 2 263 328 B1

dans lequel, lorsque le nombre de couches dans la pluralité de couches est 5, les symboles de modulation pour le premier mot de code sont mappés sur 2 couches et les symboles de modulation pour le deuxième mot de code sont mappés sur 3 couches restantes, et

5 lorsque le nombre de couches dans la pluralité de couches est 6, les symboles de modulation pour le premier mot de code sont mappés sur 3 couches et les symboles de modulation pour le deuxième mot de code sont mappés sur 3 couches restantes, et

lorsque le nombre de couches dans la pluralité de couches est 7, les symboles de modulation pour le premier mot de code sont mappés sur 3 couches et les symboles de modulation pour le deuxième mot de code sont mappés sur 4 couches restantes, et

10 lorsque le nombre de couches dans la pluralité de couches est 8, les symboles de modulation pour le premier mot de code sont mappés sur 4 couches et les symboles de modulation pour le deuxième mot de code sont mappés sur 4 couches restantes.

10. Récepteur selon la revendication 9, dans lequel, lorsque le nombre de couches dans la pluralité de couches est 5, 6, 7 ou 8, les symboles de mappage sont démappés en symboles de modulation pour le premier mot de code et en symboles de modulation pour le deuxième mot de code selon le tableau suivant :

Nombre de couches dans la pluralité de couches	Nombre de mots de code	Mappage des mots de code sur les couches $i=0, 1, \dots, M^{\text{layer}}_{\text{symb}}-1$ $M^{\text{layer}}_{\text{symb}}$: un nombre de symboles de modulation pour chaque couche de la pluralité de couches
5	2	$x^{(0)}(i)=d^{(0)}(2i)$ $x^{(1)}(i)=d^{(0)}(2i+1)$ $x^{(2)}(i)=d^{(1)}(3i)$ $x^{(3)}(i)=d^{(1)}(3i+1)$ $x^{(4)}(i)=d^{(1)}(3i+2)$ $M^{\text{layer}}_{\text{symb}}=M^{(0)}_{\text{symb}}/2=M^{(1)}_{\text{symb}}/3$
6	2	$x^{(0)}(i)=d^{(0)}(3i)$ $x^{(1)}(i)=d^{(0)}(3i+1)$ $x^{(2)}(i)=d^{(0)}(3i+2)$ $x^{(3)}(i)=d^{(1)}(3i)$ $x^{(4)}(i)=d^{(1)}(3i+1)$ $x^{(5)}(i)=d^{(1)}(3i+2)$ $M^{\text{layer}}_{\text{symb}}=M^{(0)}_{\text{symb}}/3=M^{(1)}_{\text{symb}}/3$
7	2	$x^{(0)}(i)=d^{(0)}(3i)$ $x^{(1)}(i)=d^{(0)}(3i+1)$ $x^{(2)}(i)=d^{(0)}(3i+2)$ $x^{(3)}(i)=d^{(1)}(4i)$ $x^{(4)}(i)=d^{(1)}(4i+1)$ $x^{(5)}(i)=d^{(1)}(4i+2)$ $x^{(6)}(i)=d^{(1)}(4i+3)$ $M^{\text{layer}}_{\text{symb}}=M^{(0)}_{\text{symb}}/3=M^{(1)}_{\text{symb}}/4$
8	2	$x^{(0)}(i)=d^{(0)}(4i)$ $x^{(1)}(i)=d^{(0)}(4i+1)$ $x^{(2)}(i)=d^{(0)}(4i+2)$ $x^{(3)}(i)=d^{(0)}(4i+3)$ $x^{(4)}(i)=d^{(1)}(4i)$ $x^{(5)}(i)=d^{(1)}(4i+1)$ $x^{(6)}(i)=d^{(1)}(4i+2)$ $x^{(7)}(i)=d^{(1)}(4i+3)$ $M^{\text{layer}}_{\text{symb}}=M^{(0)}_{\text{symb}}/4=M^{(1)}_{\text{symb}}/4$

55 dans lequel, dans le tableau ci-dessus, $d^{(0)}(i)$ représente les symboles de modulation pour le premier mot de code, $d^{(1)}(i)$ représente les symboles de modulation pour le deuxième mot de code, $x^{(n)}(i)$ représente des symboles de mappage mappés sur une couche n , $M^{(0)}_{\text{symb}}$ représente un nombre de symboles de modulation pour le premier mot de code et $M^{(1)}_{\text{symb}}$ représente un nombre de symboles de modulation pour le deuxième mot de code.

[Fig. 1]

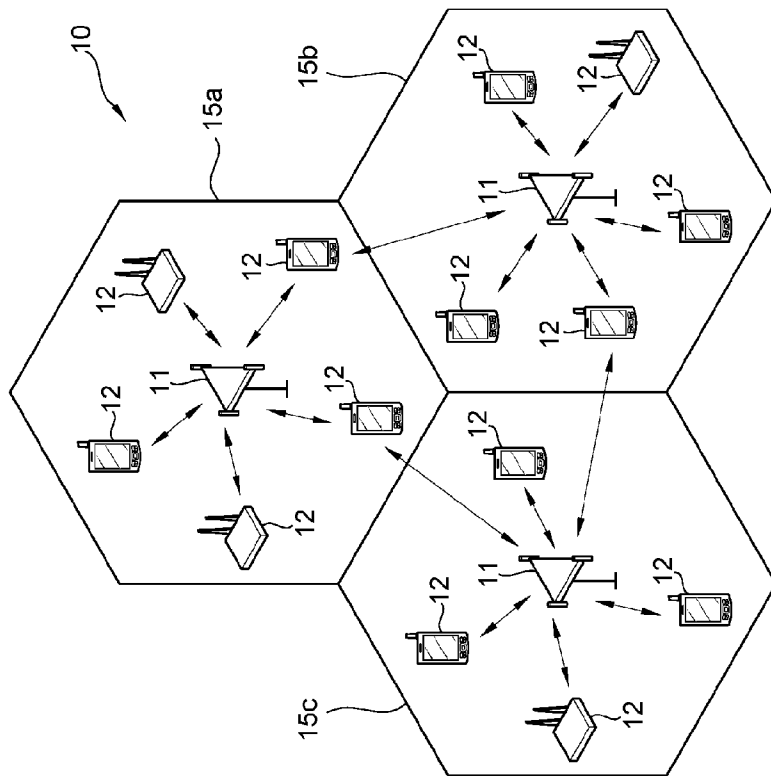

[Fig. 2]

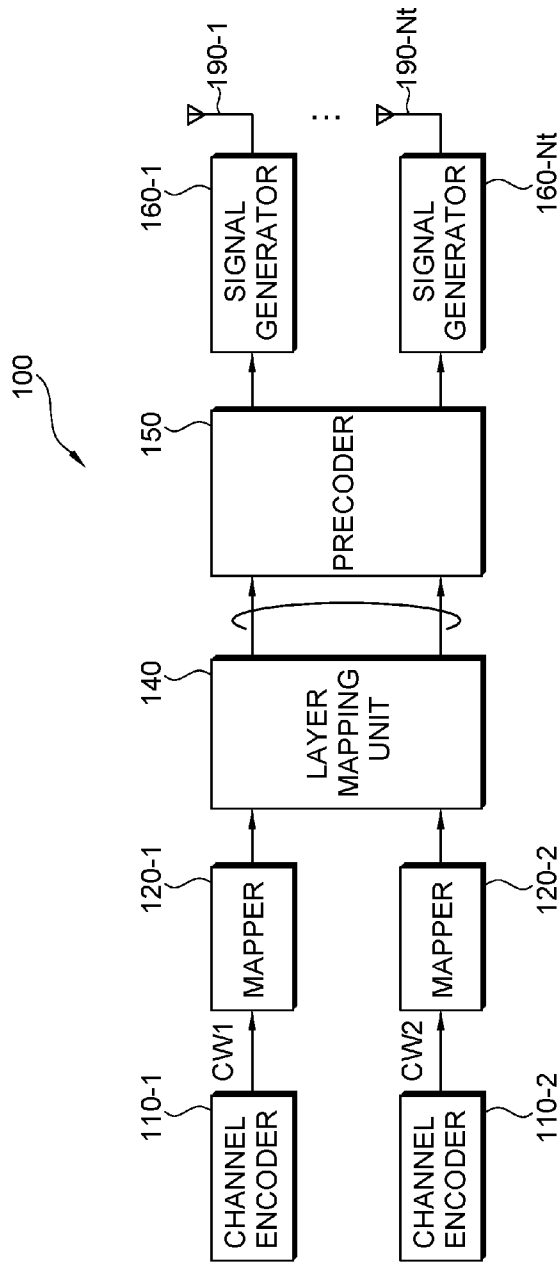

[Fig. 3]

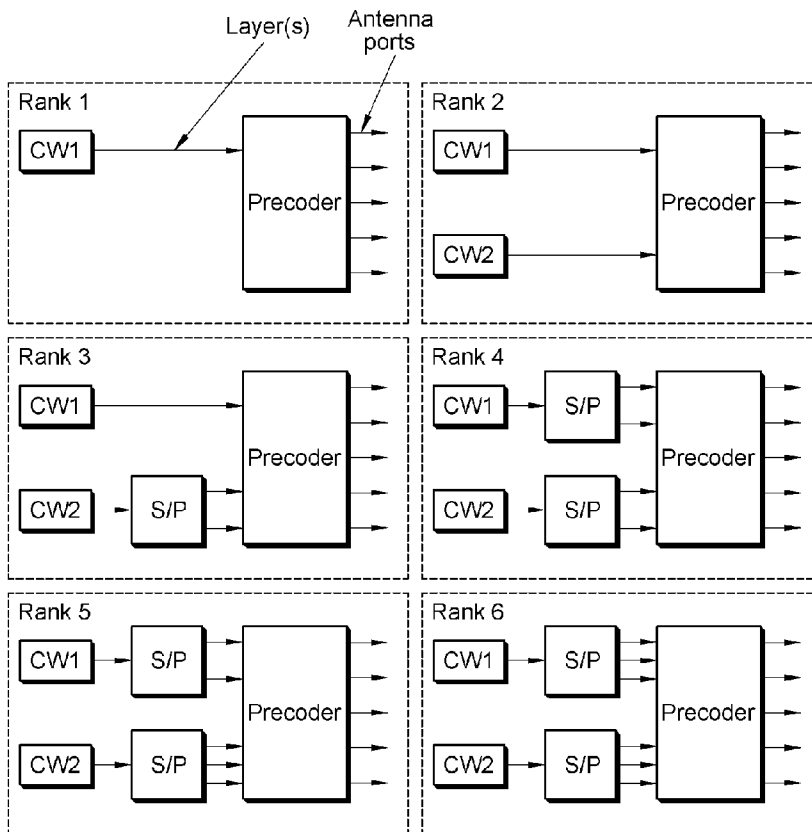

[Fig. 4]

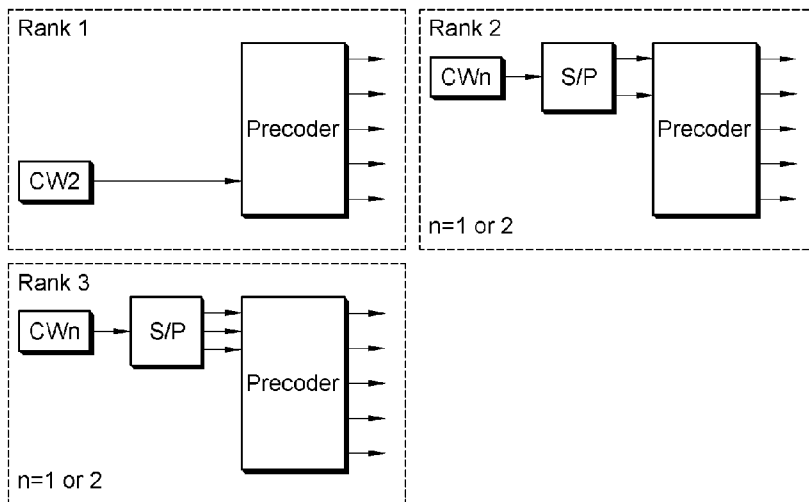

[Fig. 5]

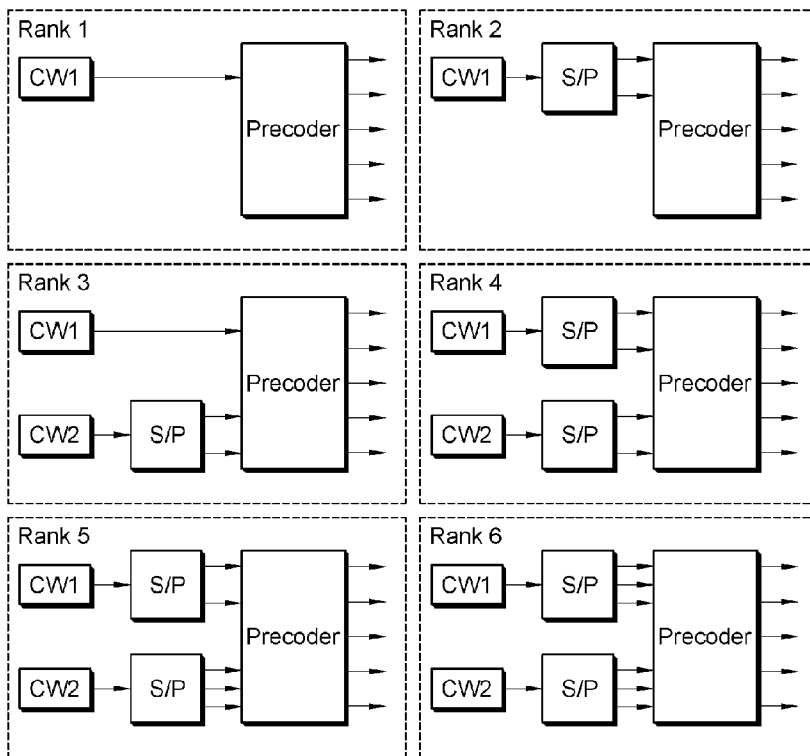

[Fig. 6]

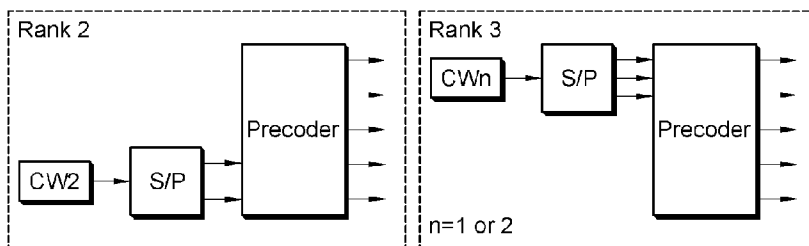

[Fig. 7]

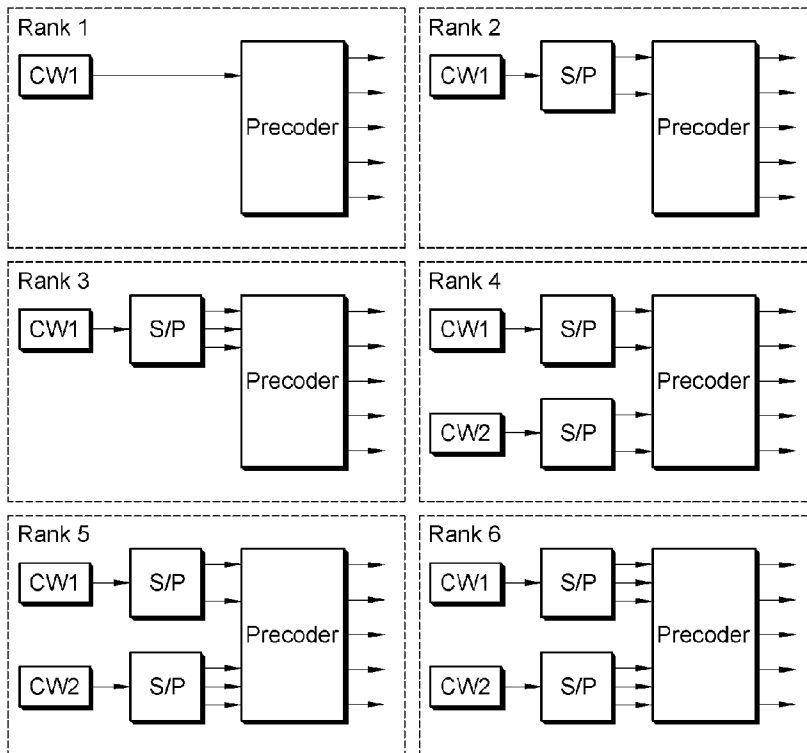

[Fig. 8]

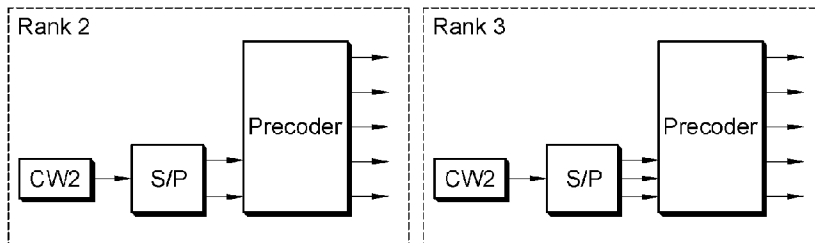

[Fig. 9]

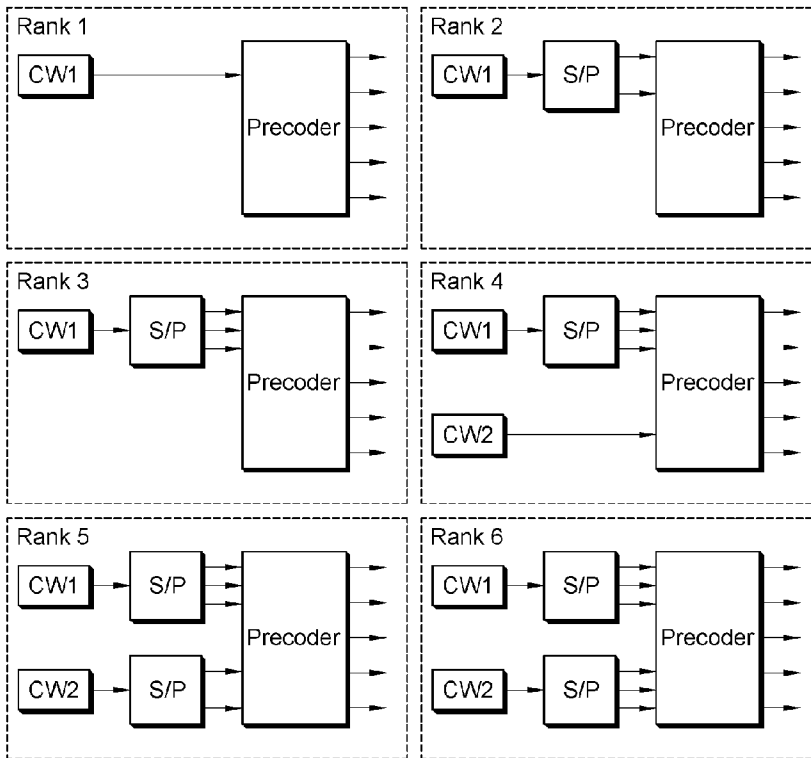

[Fig. 10]

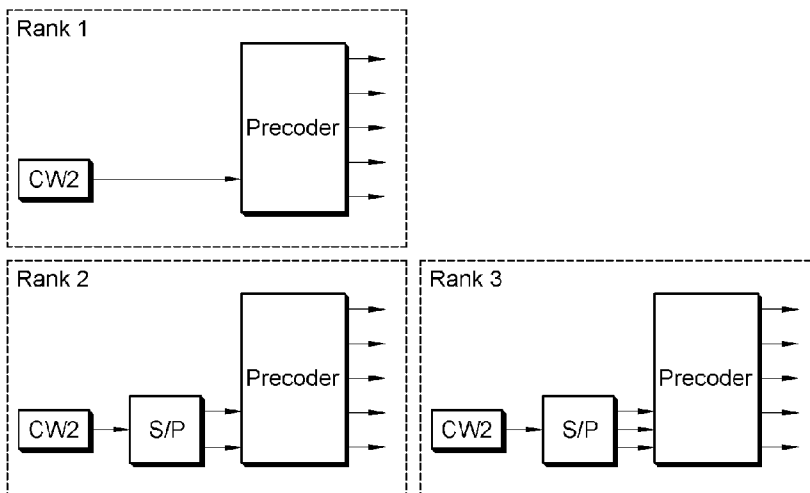

[Fig. 11]

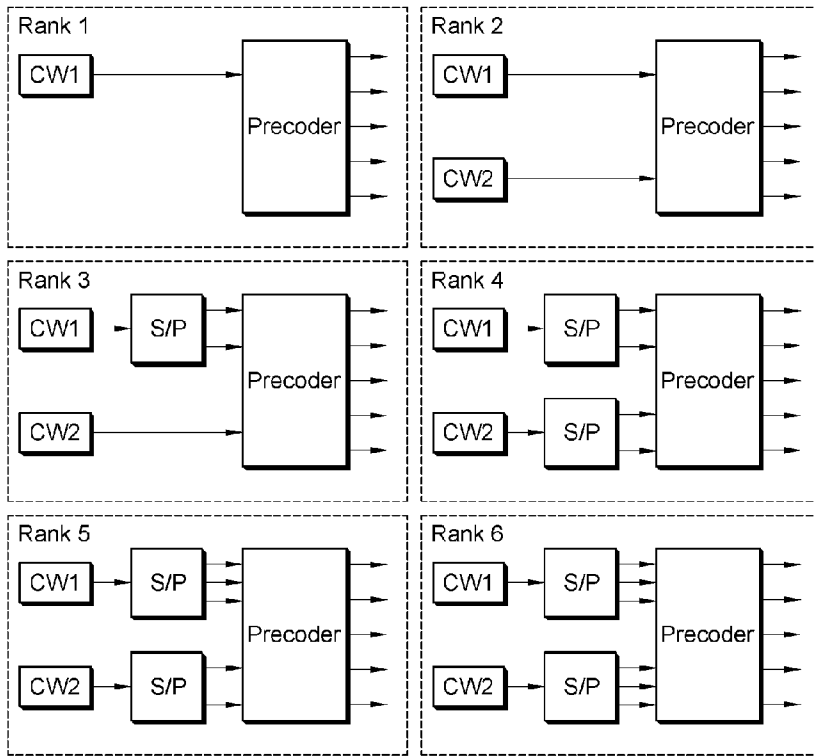

[Fig. 12]

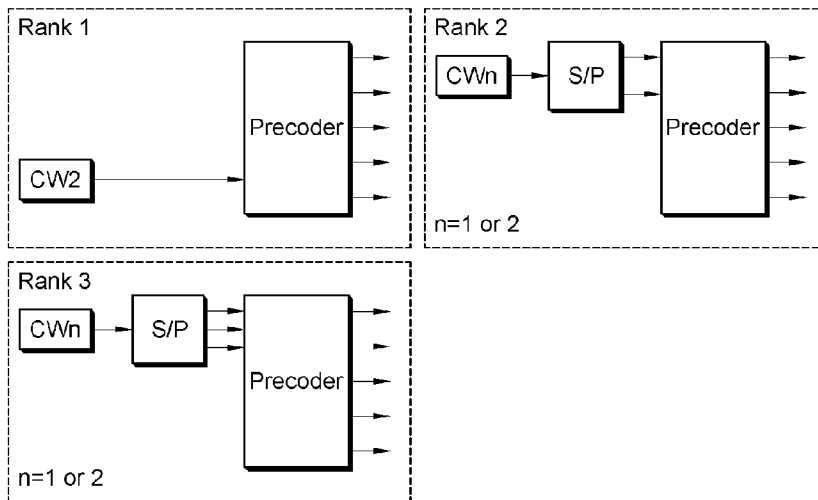

[Fig. 13]

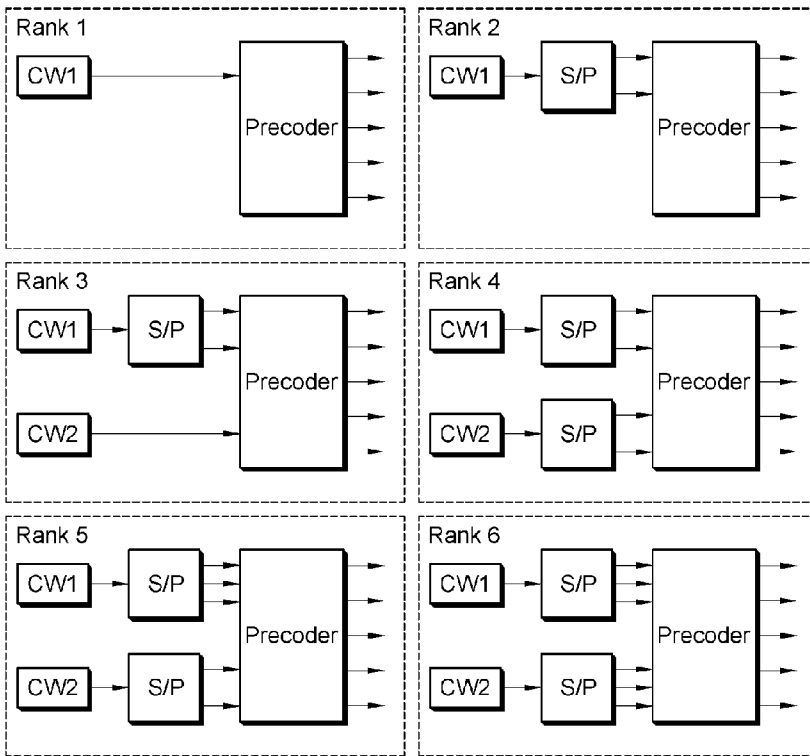

[Fig. 14]

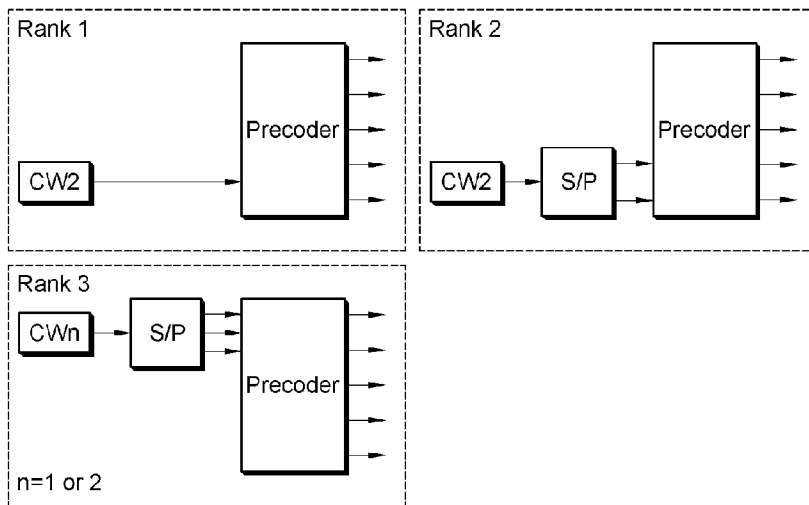

[Fig. 15]

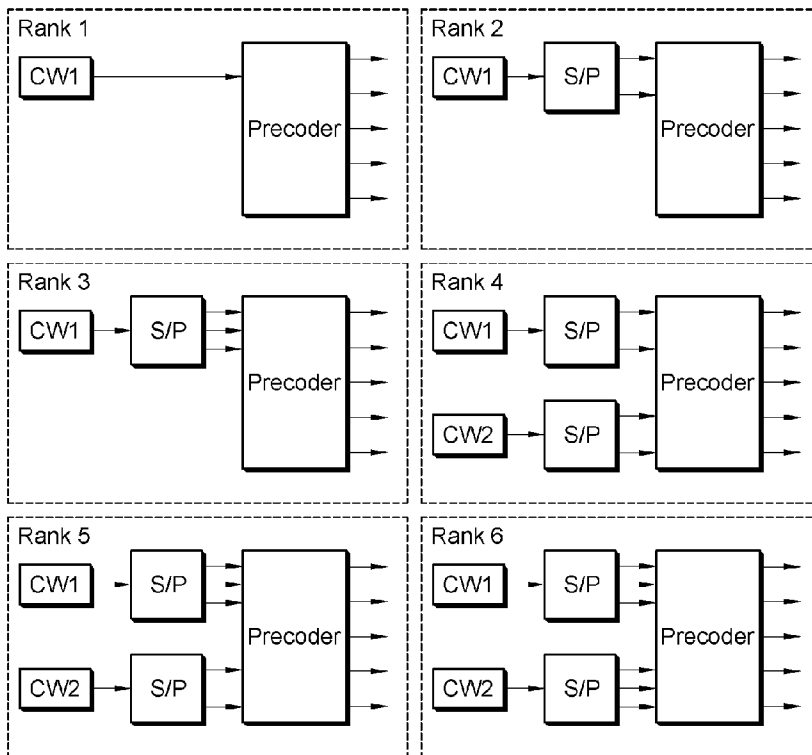

[Fig. 16]

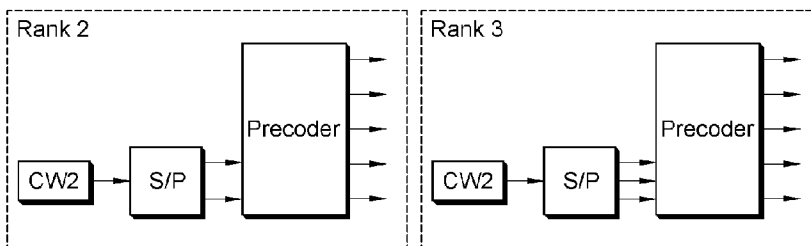

[Fig. 17]

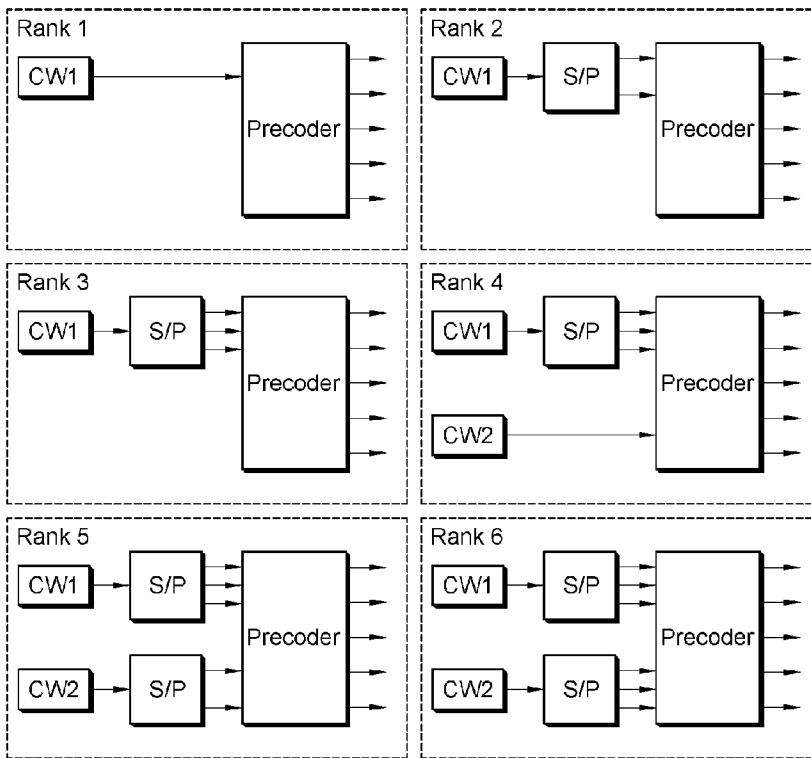

[Fig. 18]

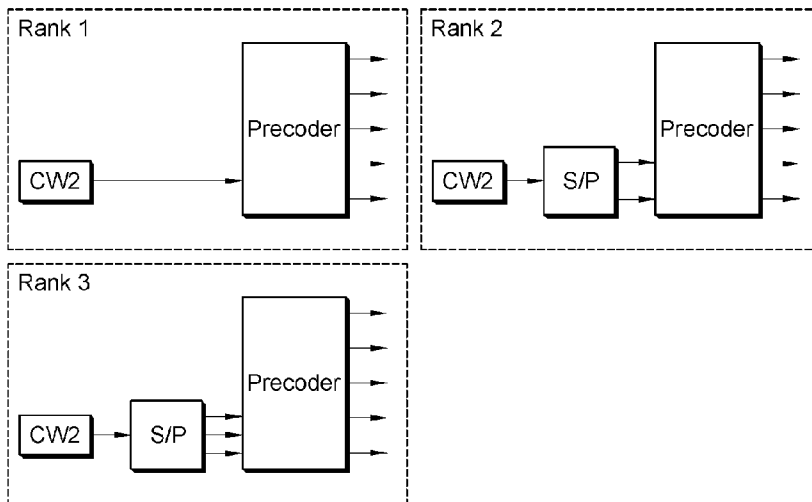

[Fig. 19]

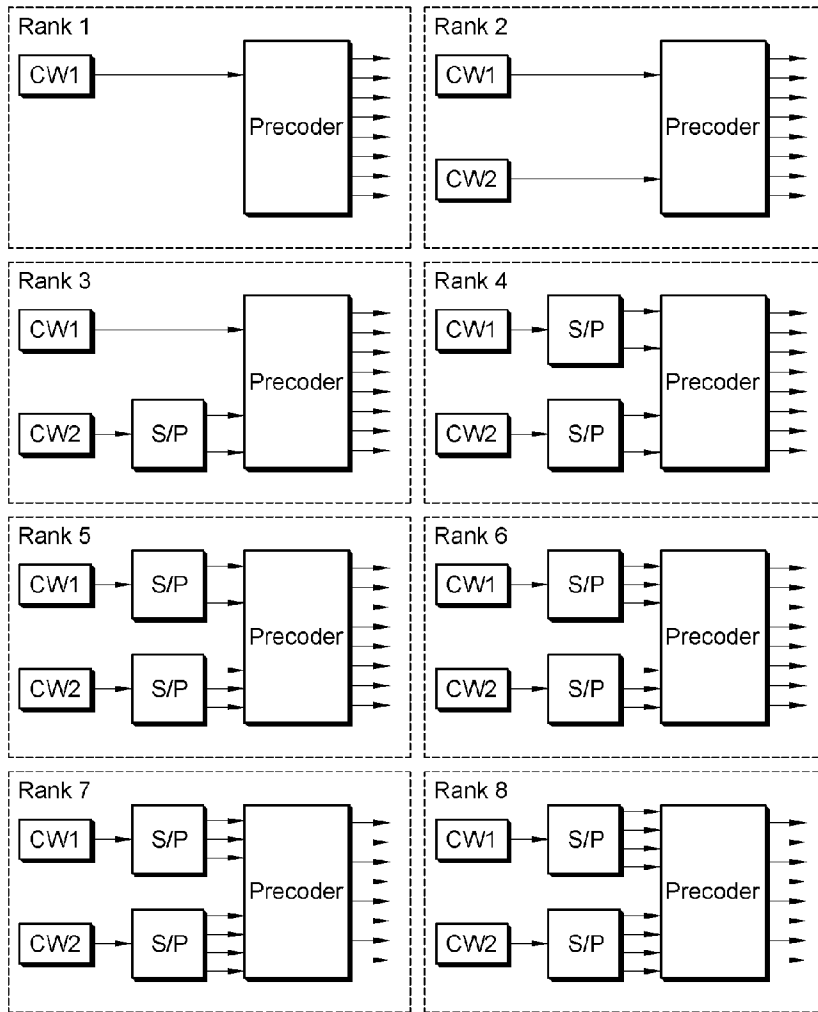

[Fig. 20]

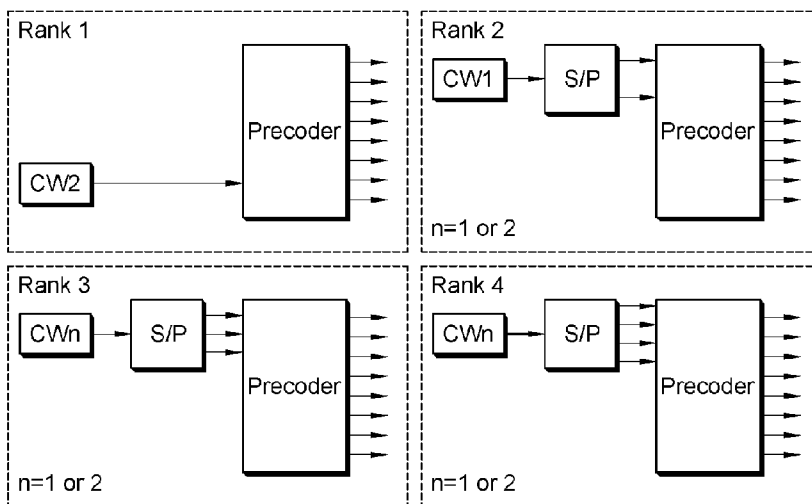

[Fig. 21]

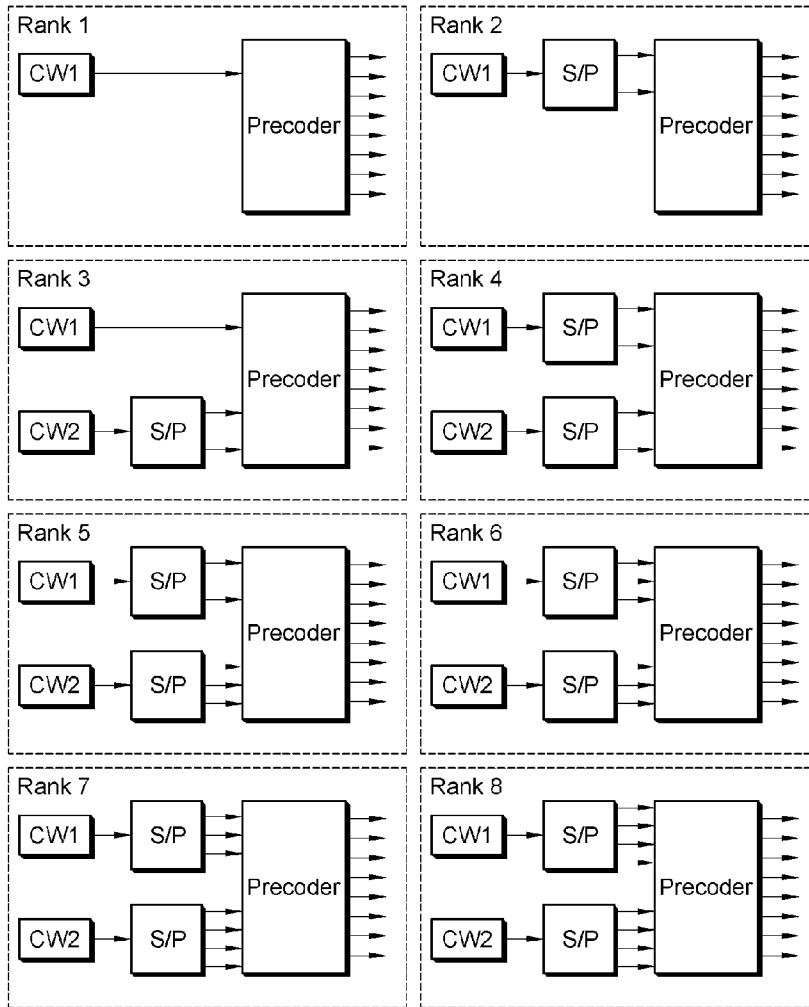

[Fig. 22]

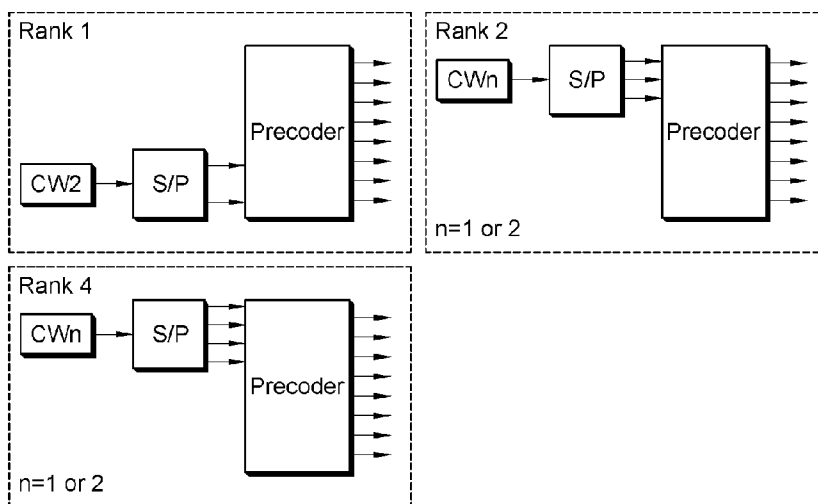

[Fig. 23]

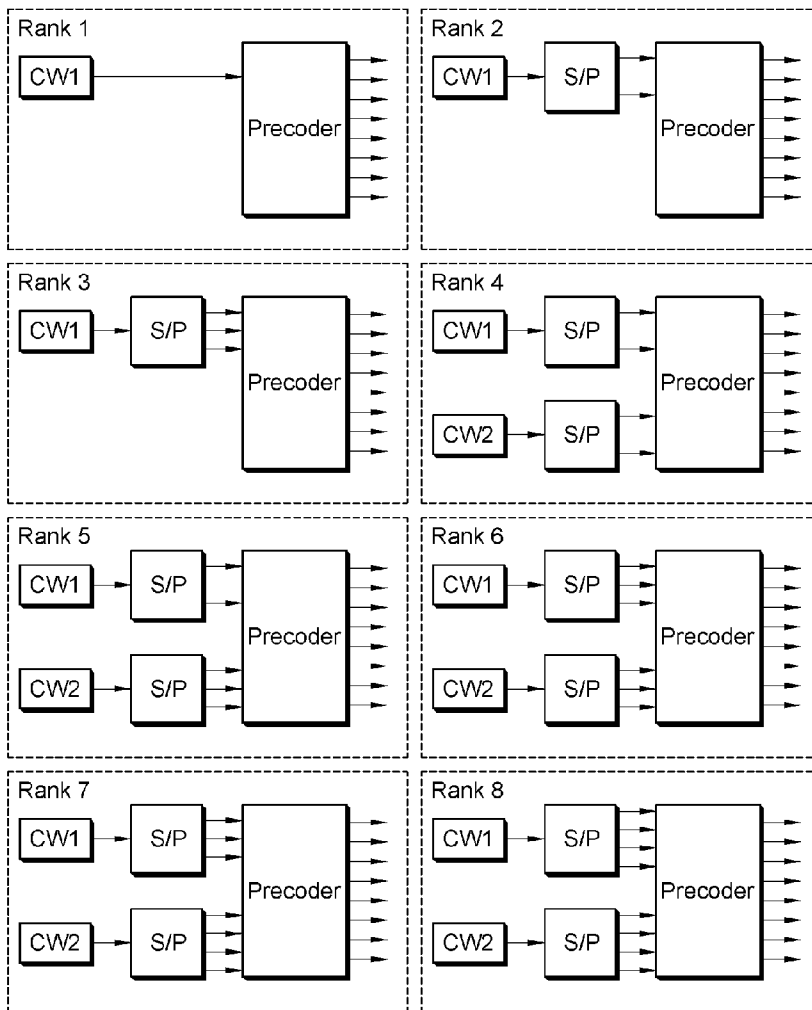

[Fig. 24]

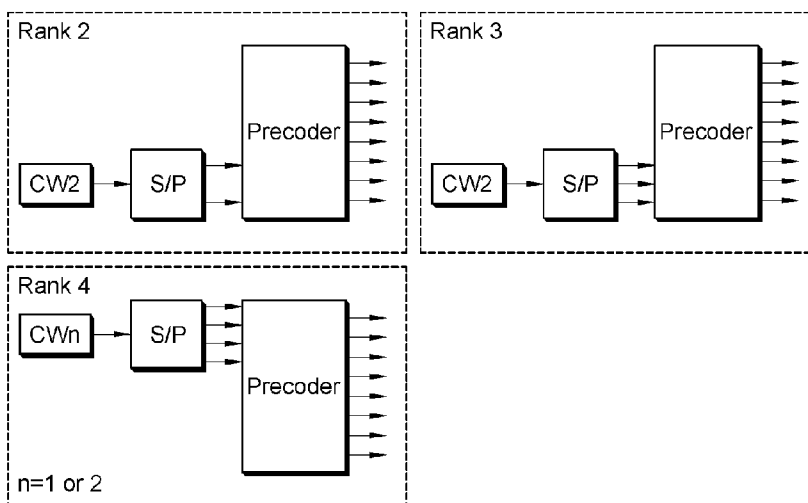

[Fig. 25]

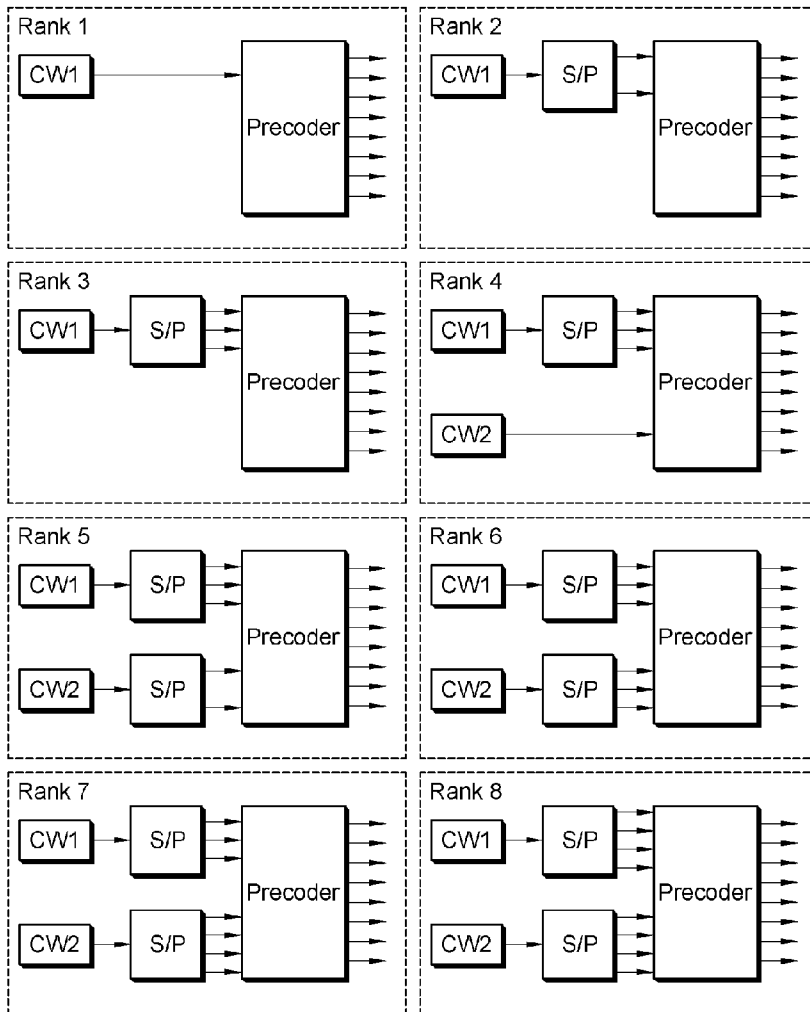

[Fig. 26]

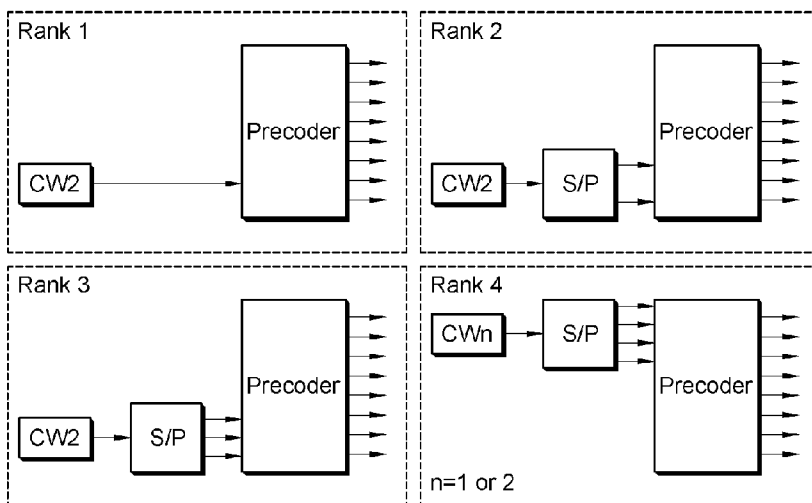

[Fig. 27]

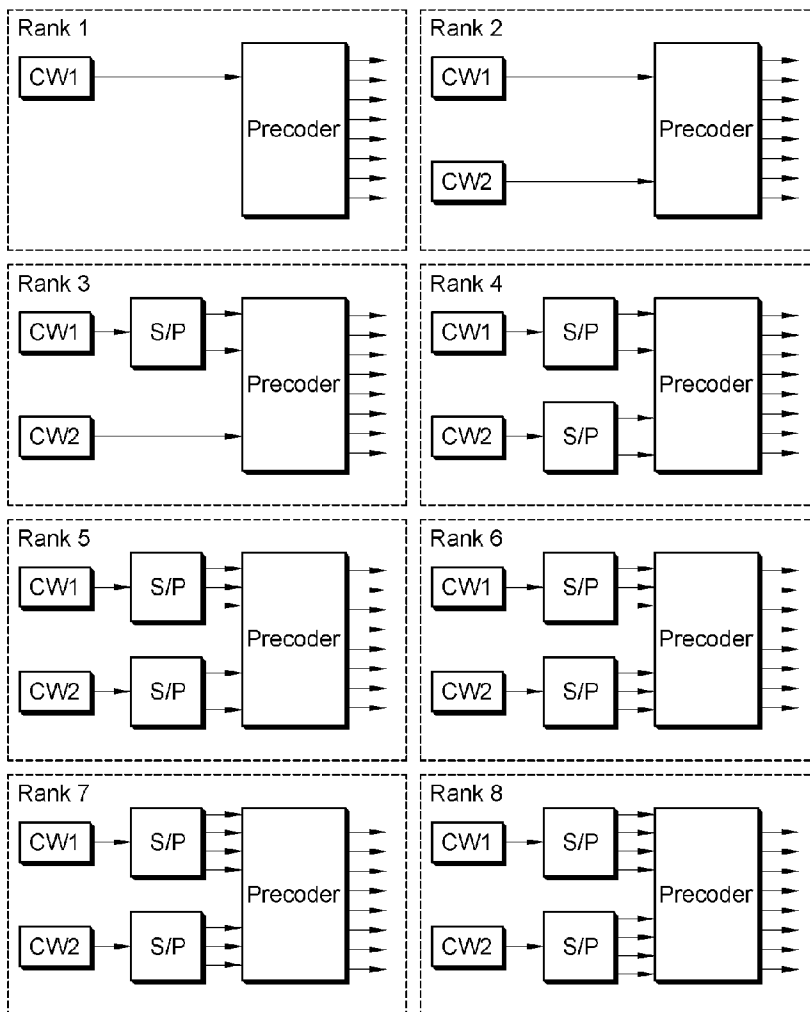

[Fig. 28]

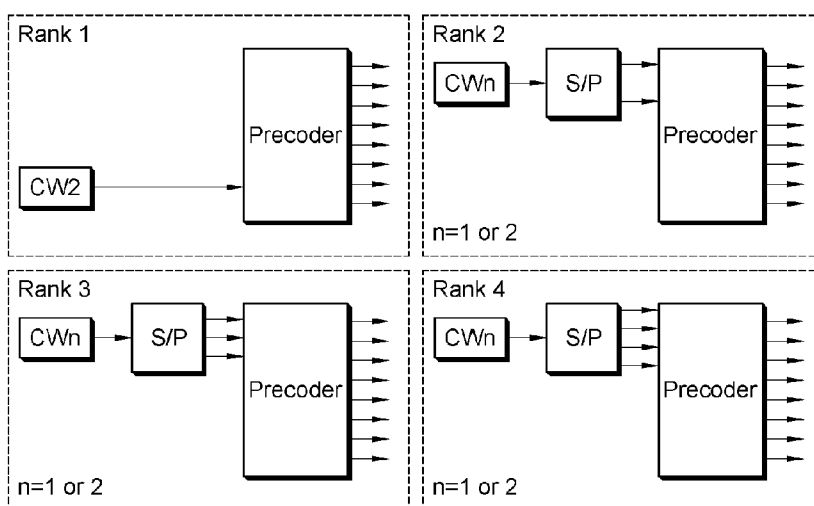

[Fig. 29]

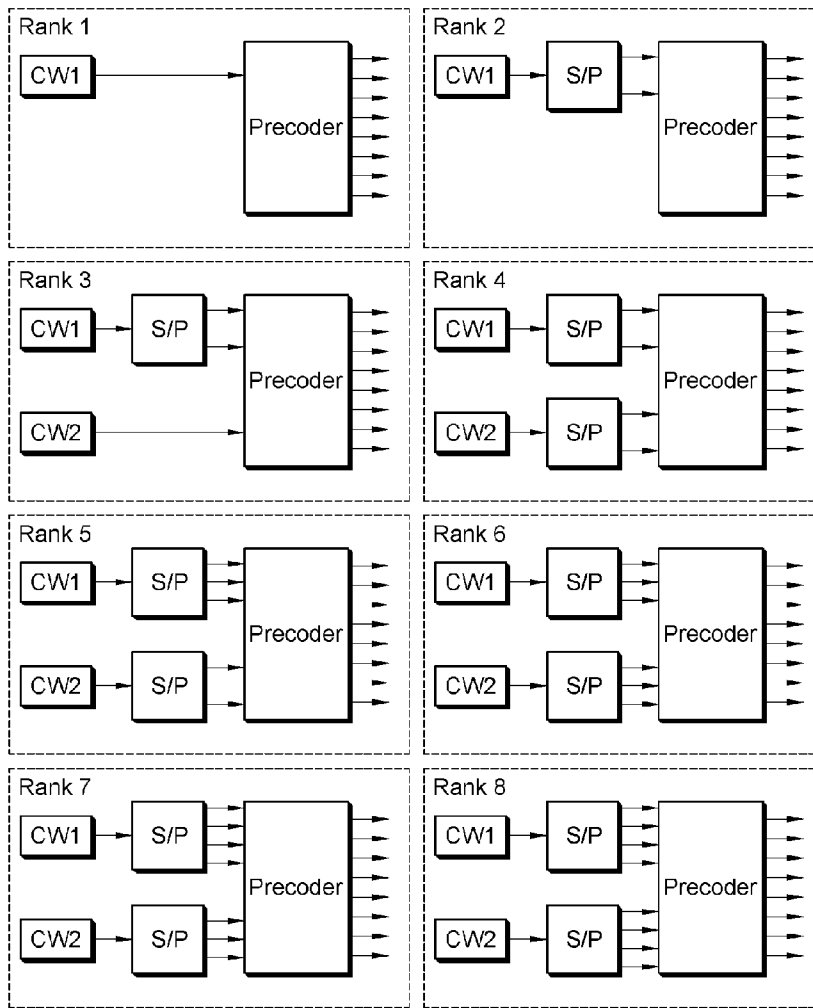

[Fig. 30]

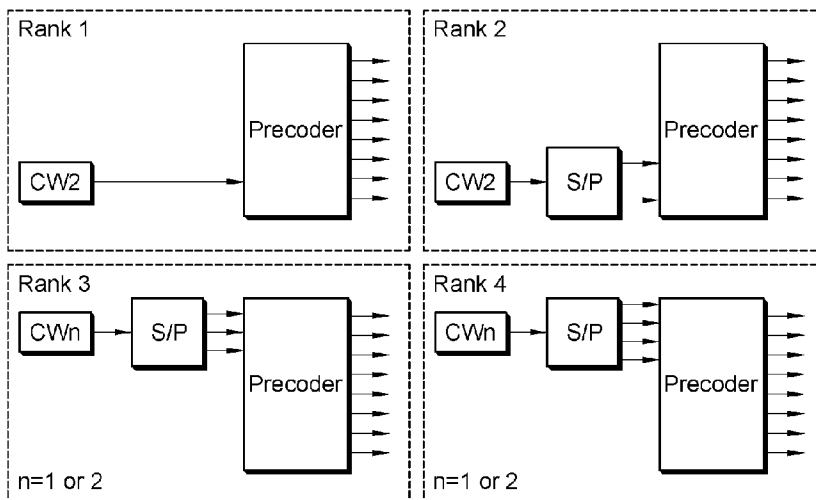

[Fig. 31]

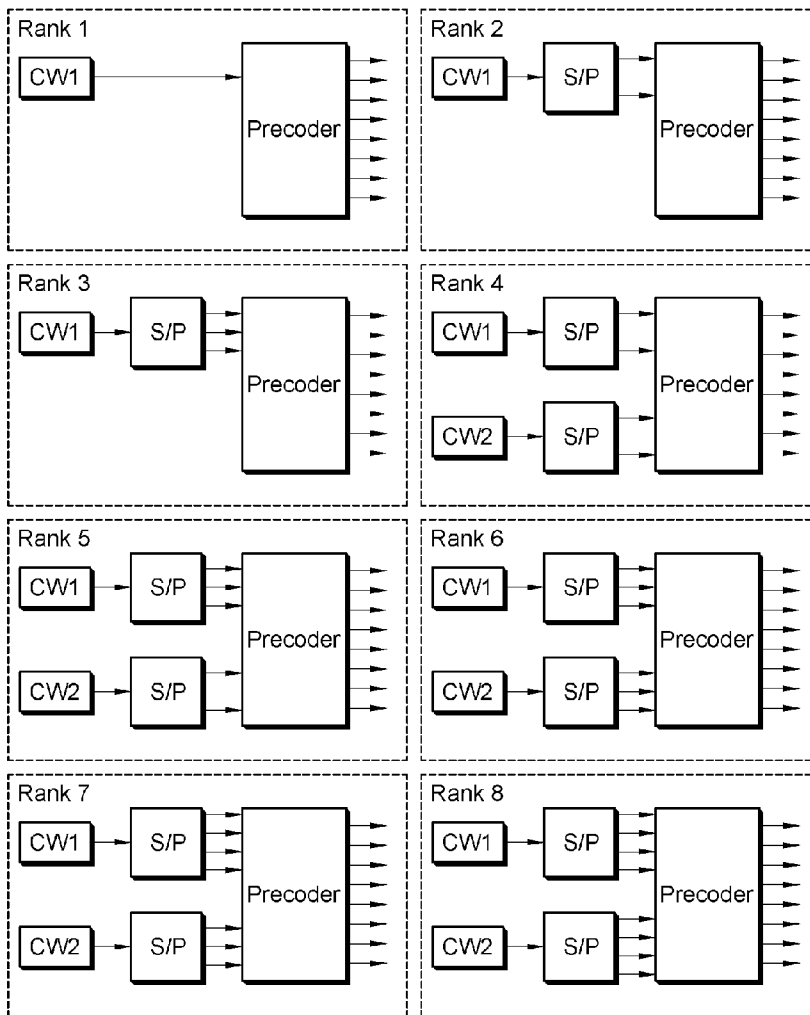

[Fig. 32]

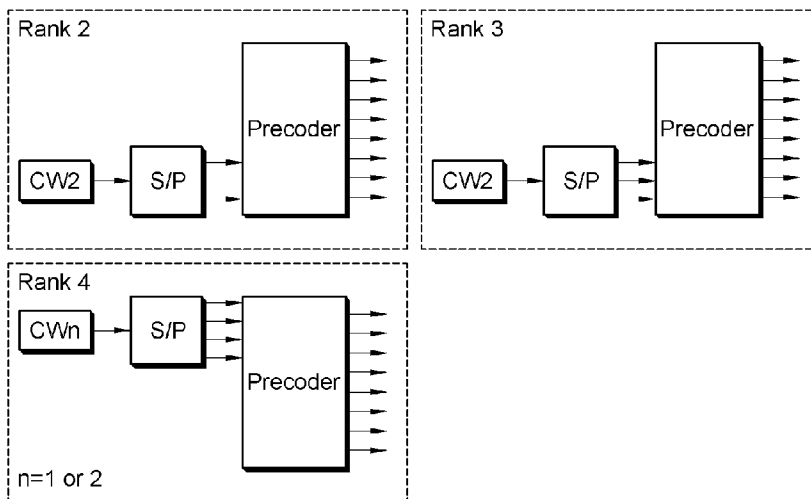

[Fig. 33]

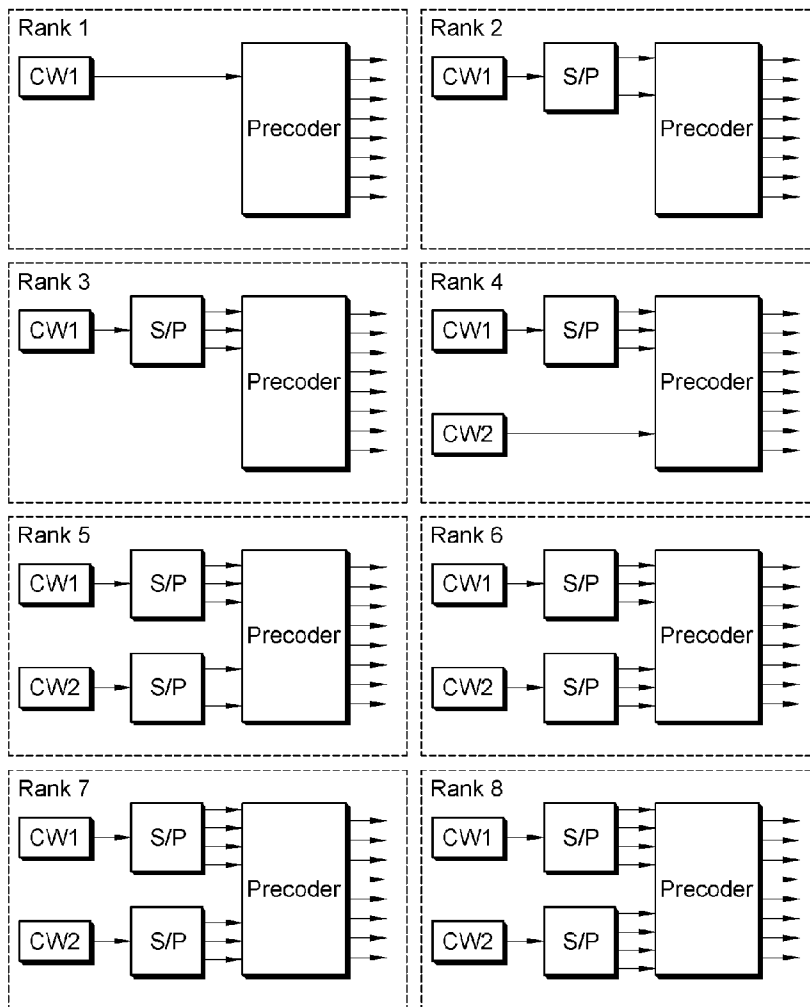

[Fig. 34]

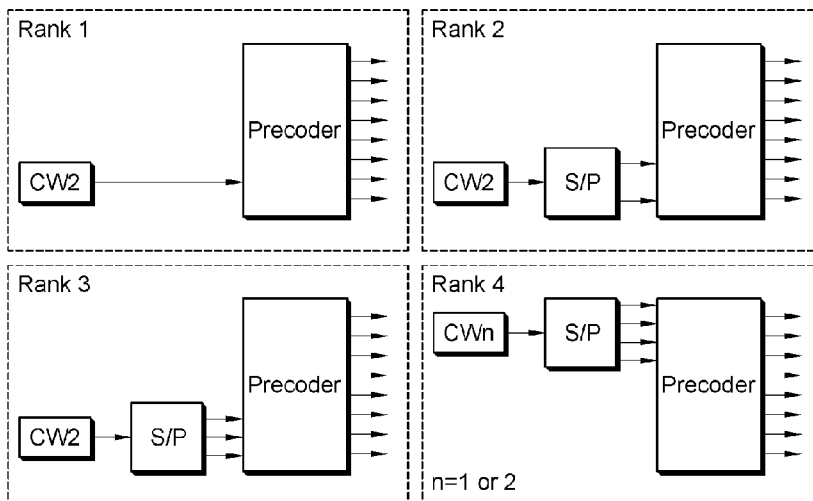

[Fig. 35]

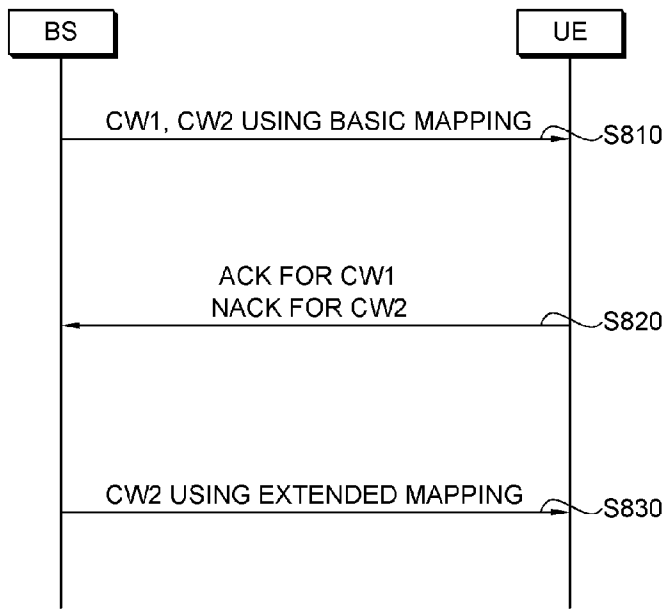

[Fig. 36]

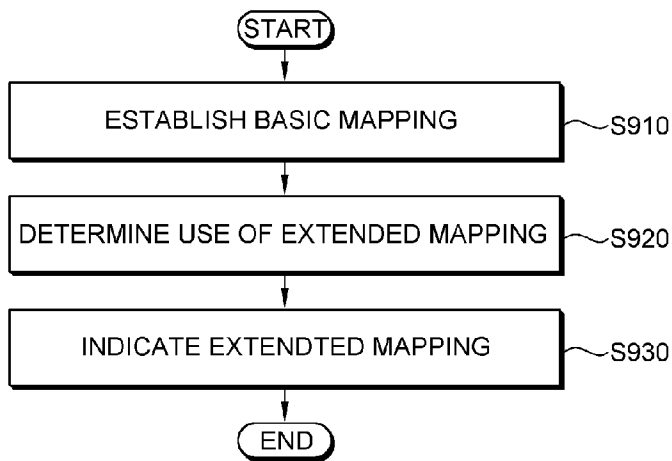

[Fig. 37]

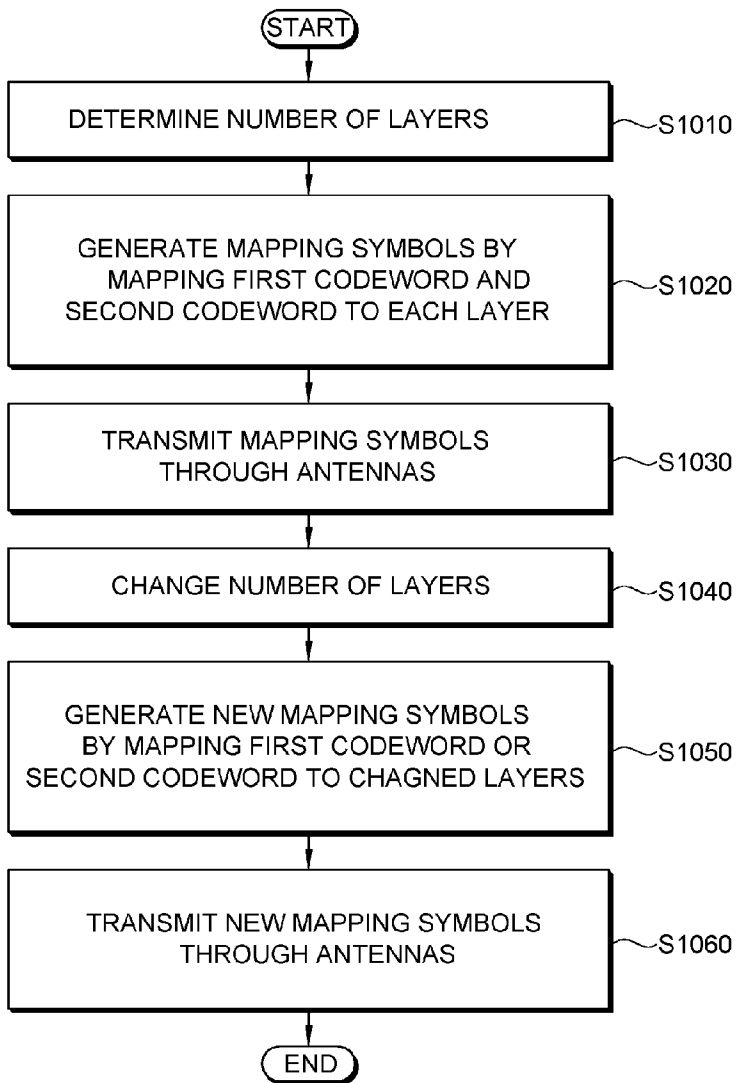

[Fig. 38]

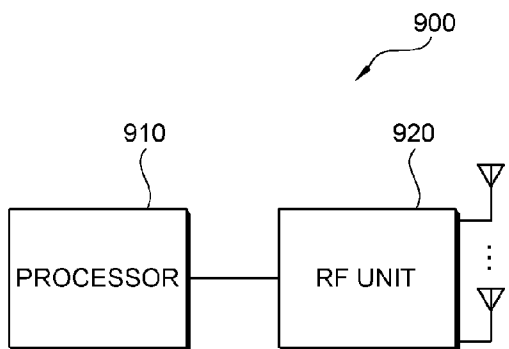

[Fig. 39]

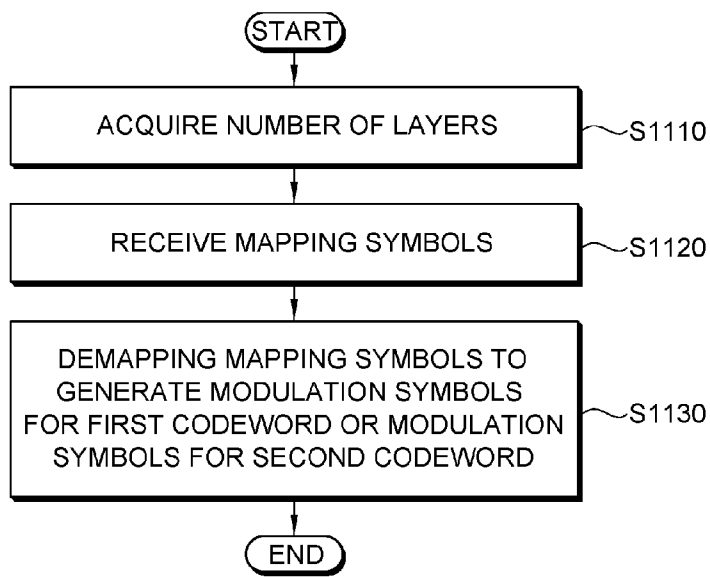

REFERENCES CITED IN THE DESCRIPTION

This list of references cited by the applicant is for the reader's convenience only. It does not form part of the European patent document. Even though great care has been taken in compiling the references, errors or omissions cannot be excluded and the EPO disclaims all liability in this regard.

Non-patent literature cited in the description

- Technical Specification Group Radio Access Network; Evolved Universal Terrestrial Radio Access (E-UTRA); Physical channels and modulation (Release 8). *3GPP TS 36.211 V8.0.0*, September 2007
[0005]

716161/KOT

ADATÁTVITELI ELJÁRÁS TÖBBANTENNÁS RENDSZERBEN

Szabadalmi igénypontok

1. Adatátviteli eljárás többantennás rendszerben, az eljárás a következőket tartalmazza:

leképező jelek előállítására első kódszóhoz való modulálási jeleknek és második kódszóhoz való modulálási jeleknek rétegek sokaságára való leképezésére; és a leképező jelek adása antennák sokaságán keresztül,

azzal jellemezve, hogy amikor a rétegek sokaságának száma nagyobb, mint 4, legalább egy, az első kódszóhoz való modulálási jel és egy, a második kódszóhoz való modulálási jel leképeződik legalább 3 rétegre,

ahol ha a rétegek sokaságának száma nagyobb, mint 5, az első kódszóhoz való modulálási jelek 2 rétegre, a második kódszóhoz tartozó modulálási jelek pedig a fennmaradó 3 rétegre képeződnek le, és

amikor a rétegek sokaságának száma 6, az első kódszóhoz való modulálási jelek 3 rétegre, a második kódszóhoz tartozó modulálási jelek pedig a fennmaradó 3 rétegre képeződnek le, és

amikor a rétegek sokaságának száma 7, az első kódszóhoz való modulálási jelek 3 rétegre, a második kódszóhoz tartozó modulálási jelek pedig a fennmaradó 4 rétegre képeződnek le, és

amikor a rétegek sokaságának száma 8, az első kódszóhoz való modulálási jelek 4 rétegre, a második kódszóhoz tartozó modulálási jelek pedig a fennmaradó 4 rétegre képeződnek le.

2. Az 1. igénypont szerinti eljárás, ahol a rétegek sokaságának a száma kisebb vagy egyenlő az antennák sokaságának a számával.
3. Az 1. igénypont szerinti eljárás továbbá a következőket tartalmazza: a rétegek sokaságának a meghatározása.

4. Az 1. igénypont szerinti eljárás,

ahol amikor a rétegek sokaságának a száma 5, 6, 7 vagy 8, az első kódszóhoz való modulálási jelek és a második kódszóhoz való modulálási jelek a következő táblázat szerint képeződnek le rétegekre:

Rétegek száma	Kódszavak száma	Kódszó rétegre való leképezése $i = 0, 1, \dots, M_{\text{symb}}^{\text{layer}} - 1,$ $M_{\text{symb}}^{\text{layer}}$: modulálási jelek száma a rétegek sokaságának minden egyes rétegére
5	2	$x^{(0)}(i) = d^{(0)}(2i)$ $x^{(1)}(i) = d^{(0)}(2i+1)$ $x^{(2)}(i) = d^{(1)}(3i)$ $x^{(3)}(i) = d^{(1)}(3i+1)$ $x^{(4)}(i) = d^{(1)}(3i+2)$ $M_{\text{symb}}^{\text{layer}} = M_{\text{symb}}^{(0)}/2 = M_{\text{symb}}^{(1)}/3$
6	2	$x^{(0)}(i) = d^{(0)}(3i)$ $x^{(1)}(i) = d^{(0)}(3i+1)$ $x^{(2)}(i) = d^{(0)}(3i+2)$ $x^{(3)}(i) = d^{(1)}(3i)$ $x^{(4)}(i) = d^{(1)}(3i+1)$ $x^{(5)}(i) = d^{(1)}(3i+2)$ $M_{\text{symb}}^{\text{layer}} = M_{\text{symb}}^{(0)}/3 = M_{\text{symb}}^{(1)}/3$
7	2	$x^{(0)}(i) = d^{(0)}(3i)$ $x^{(1)}(i) = d^{(0)}(3i+1)$ $x^{(2)}(i) = d^{(0)}(3i+2)$ $x^{(3)}(i) = d^{(1)}(4i)$ $x^{(4)}(i) = d^{(1)}(4i+1)$ $x^{(5)}(i) = d^{(1)}(4i+2)$ $x^{(6)}(i) = d^{(1)}(4i+3)$ $M_{\text{symb}}^{\text{layer}} = M_{\text{symb}}^{(0)}/3 = M_{\text{symb}}^{(1)}/4$
8	2	$x^{(0)}(i) = d^{(0)}(4i)$ $x^{(1)}(i) = d^{(0)}(4i+1)$ $x^{(2)}(i) = d^{(0)}(4i+2)$ $x^{(3)}(i) = d^{(0)}(4i+3)$ $x^{(4)}(i) = d^{(1)}(4i)$ $M_{\text{symb}}^{\text{layer}} = M_{\text{symb}}^{(0)}/4 = M_{\text{symb}}^{(1)}/4$

		$x^{(5)}(i) = d^{(1)}(4i+1)$ $x^{(6)}(i) = d^{(1)}(4i+2)$ $x^{(7)}(i) = d^{(1)}(4i+3)$
--	--	--

ahol a fenti táblázatban $d^{(0)}(i)$ az első kódszóhoz való modulálási jelek, $d^{(1)}(i)$ a második kódszóhoz való modulálási jelek, $x^{(n)}(i)$ az n rétegre leképezett leképezési jelek, $M^{(0)}_{\text{sym}}$ az első kódszóhoz való modulálási jelek száma, $M^{(1)}_{\text{sym}}$ pedig a második kódszóhoz való modulálási jelek száma.

5. Adó (900), amely a következőket tartalmazza:

RF rádiófrekvenciás egység (920) rádiójel adására és vételére; és
 az RF egységhez csatolt processzor (910),

ahol a processzor (910) leképező jeleket állít elő első kódszóhoz való modulálási jeleknek és második kódszóhoz való modulálási jeleknek rétegek sokaságára való leképezésére, és továbbítja a leképezési jeleket,

azzal jellemezve, hogy amikor a rétegek sokaságának száma nagyobb, mint 4, legalább egy, az első kódszóhoz való modulálási jel és egy, a második kódszóhoz való modulálási jel leképeződik legalább 3 rétegre, és

ahol ha a rétegek sokaságának száma nagyobb, mint 5, az első kódszóhoz való modulálási jelek 2 rétegre, a második kódszóhoz tartozó modulálási jelek pedig a fennmaradó 3 rétegre képeződnek le, és

amikor a rétegek sokaságának száma 6, az első kódszóhoz való modulálási jelek 3 rétegre, a második kódszóhoz tartozó modulálási jelek pedig a fennmaradó 3 rétegre képeződnek le, és

amikor a rétegek sokaságának száma 7, az első kódszóhoz való modulálási jelek 3 rétegre, a második kódszóhoz tartozó modulálási jelek pedig a fennmaradó 4 rétegre képeződnek le, és

amikor a rétegek sokaságának száma 8, az első kódszóhoz való modulálási jelek 4 rétegre, a második kódszóhoz tartozó modulálási jelek pedig a fennmaradó 4 rétegre képeződnek le.



6. Az 5. igénypont szerinti adó (900),

ahol amikor a rétegek sokaságának a száma 5, 6, 7 vagy 8, az első kódszóhoz való modulálási jelek és a második kódszóhoz való modulálási jelek a következő táblázat szerint képeződnek le rétegekre:

Rétegek sokaságának a száma	Kódszavak száma	Kódszó rétegre való leképezése $i = 0, 1, \dots, M_{\text{symb}}^{\text{layer}} - 1$, $M_{\text{symb}}^{\text{layer}}$: modulálási jelek száma a rétegek sokaságának minden egyes rétegeire
5	2	$x^{(0)}(i) = d^{(0)}(2i)$ $x^{(1)}(i) = d^{(0)}(2i+1)$ $x^{(2)}(i) = d^{(1)}(3i)$ $x^{(3)}(i) = d^{(1)}(3i+1)$ $x^{(4)}(i) = d^{(1)}(3i+2)$ $M_{\text{symb}}^{\text{layer}} = M_{\text{symb}}^{(0)} \cdot 2 = M_{\text{symb}}^{(1)} \cdot 3$
6	2	$x^{(0)}(i) = d^{(0)}(3i)$ $x^{(1)}(i) = d^{(0)}(3i+1)$ $x^{(2)}(i) = d^{(0)}(3i+2)$ $x^{(3)}(i) = d^{(1)}(3i)$ $x^{(4)}(i) = d^{(1)}(3i+1)$ $x^{(5)}(i) = d^{(1)}(3i+2)$ $M_{\text{symb}}^{\text{layer}} = M_{\text{symb}}^{(0)} \cdot 3 = M_{\text{symb}}^{(1)} \cdot 3$
7	2	$x^{(0)}(i) = d^{(0)}(3i)$ $x^{(1)}(i) = d^{(0)}(3i+1)$ $x^{(2)}(i) = d^{(0)}(3i+2)$ $x^{(3)}(i) = d^{(1)}(4i)$ $x^{(4)}(i) = d^{(1)}(4i+1)$ $x^{(5)}(i) = d^{(1)}(4i+2)$ $x^{(6)}(i) = d^{(1)}(4i+3)$ $M_{\text{symb}}^{\text{layer}} = M_{\text{symb}}^{(0)} \cdot 3 = M_{\text{symb}}^{(1)} \cdot 4$
8	2	$x^{(0)}(i) = d^{(0)}(4i)$ $x^{(1)}(i) = d^{(0)}(4i+1)$ $x^{(2)}(i) = d^{(0)}(4i+2)$ $x^{(3)}(i) = d^{(0)}(4i+3)$ $x^{(4)}(i) = d^{(1)}(4i)$ $M_{\text{symb}}^{\text{layer}} = M_{\text{symb}}^{(0)} \cdot 4 = M_{\text{symb}}^{(1)} \cdot 4$

		$x^{(5)}(i)=d^{(1)}(4i+1)$ $x^{(6)}(i)=d^{(1)}(4i+2)$ $x^{(7)}(i)=d^{(1)}(4i+3)$
--	--	--

ahol a fenti táblázatban $d^{(0)}(i)$ az első kódszóhoz való modulálási jelek, $d^{(1)}(i)$ a második kódszóhoz való modulálási jelek, $x^{(n)}(i)$ az n rétegre leképezett leképezési jelek, $M^{(0)}_{\text{symb}}$ az első kódszóhoz való modulálási jelek száma, $M^{(1)}_{\text{symb}}$ pedig a második kódszóhoz való modulálási jelek száma.

7. Adatvételi eljárás többantennás rendszerben, az eljárás a következőket tartalmazza:

olyan leképezési jelek vétele, amelyek rétegek sokaságára vannak leképezve;
a leképezési jelek kibontása első kódszóhoz való modulálási jeleknek és második kódszóhoz való modulálási jeleknek az előállítására,

azzal jellemezve, hogy amikor a rétegek sokaságának száma nagyobb, mint 4, legalább egy, az első kódszóhoz való modulálási jel és egy, a második kódszóhoz való modulálási jel leképeződik legalább 3 rétegre,

ahol ha a rétegek sokaságának száma nagyobb, mint 5, az első kódszóhoz való modulálási jelek 2 rétegre, a második kódszóhoz tartozó modulálási jelek pedig a fennmaradó 3 rétegre képeződnek le, és

amikor a rétegek sokaságának száma 6, az első kódszóhoz való modulálási jelek 3 rétegre, a második kódszóhoz tartozó modulálási jelek pedig a fennmaradó 3 rétegre képeződnek le, és

amikor a rétegek sokaságának száma 7, az első kódszóhoz való modulálási jelek 3 rétegre, a második kódszóhoz tartozó modulálási jelek pedig a fennmaradó 4 rétegre képeződnek le, és

amikor a rétegek sokaságának száma 8, az első kódszóhoz való modulálási jelek 4 rétegre, a második kódszóhoz tartozó modulálási jelek pedig a fennmaradó 4 rétegre képeződnek le.

8. A 7. igénypont szerinti eljárás, ahol amikor a rétegek sokaságának a száma 5, 6, 7 vagy 8, a leképező jelek kibontódnak az első kódszóhoz való modulálási jelekre és a második kódszóhoz való modulálási jelekre a következő táblázat szerint:

Rétegek sokaságának a száma	Kódszavak száma	Kódszó rétegre való leképezése $i = 0, 1, \dots, M_{\text{symb}}^{\text{layer}} - 1,$ $M_{\text{symb}}^{\text{layer}}$: modulálási jelek száma a rétegek sokaságának minden egyes rétegére
5	2	$x^{(0)}(i) = d^{(0)}(2i)$ $x^{(1)}(i) = d^{(0)}(2i+1)$ $x^{(2)}(i) = d^{(1)}(3i)$ $x^{(3)}(i) = d^{(1)}(3i+1)$ $x^{(4)}(i) = d^{(1)}(3i+2)$ $M_{\text{symb}}^{\text{layer}} = M_{\text{symb}}^{(0)}/2 = M_{\text{symb}}^{(1)}/3$
6	2	$x^{(0)}(i) = d^{(0)}(3i)$ $x^{(1)}(i) = d^{(0)}(3i+1)$ $x^{(2)}(i) = d^{(0)}(3i+2)$ $x^{(3)}(i) = d^{(1)}(3i)$ $x^{(4)}(i) = d^{(1)}(3i+1)$ $x^{(5)}(i) = d^{(1)}(3i+2)$ $M_{\text{symb}}^{\text{layer}} = M_{\text{symb}}^{(0)}/3 = M_{\text{symb}}^{(1)}/3$
7	2	$x^{(0)}(i) = d^{(0)}(3i)$ $x^{(1)}(i) = d^{(0)}(3i+1)$ $x^{(2)}(i) = d^{(0)}(3i+2)$ $x^{(3)}(i) = d^{(1)}(4i)$ $x^{(4)}(i) = d^{(1)}(4i+1)$ $x^{(5)}(i) = d^{(1)}(4i+2)$ $x^{(6)}(i) = d^{(1)}(4i+3)$ $M_{\text{symb}}^{\text{layer}} = M_{\text{symb}}^{(0)}/3 = M_{\text{symb}}^{(1)}/4$
8	2	$x^{(0)}(i) = d^{(0)}(4i)$ $x^{(1)}(i) = d^{(0)}(4i+1)$ $x^{(2)}(i) = d^{(0)}(4i+2)$ $x^{(3)}(i) = d^{(0)}(4i+3)$ $x^{(4)}(i) = d^{(1)}(4i)$ $x^{(5)}(i) = d^{(1)}(4i+1)$ $M_{\text{symb}}^{\text{layer}} = M_{\text{symb}}^{(0)}/4 = M_{\text{symb}}^{(1)}/4$

		$x^{(6)}(i)=d^{(1)}(4i+2)$ $x^{(7)}(i)=d^{(1)}(4i+3)$
--	--	--

ahol a fenti táblázatban $d^{(0)}(i)$ az első kódszóhoz való modulálási jelek, $d^{(1)}(i)$ a második kódszóhoz való modulálási jelek, $x^{(n)}(i)$ az n rétegre leképezett leképezési jelek, $M^{(0)}_{\text{symsb}}$ az első kódszóhoz való modulálási jelek száma, $M^{(1)}_{\text{symsb}}$ pedig a második kódszóhoz való modulálási jelek száma.

9. Vevő, amely a következőket tartalmazza:

RF rádiófrekvenciás egység rádiójel adására és vételére; és
az RF egységhez csatolt processzor,

ahol a processzor veszi a leképező jeleket, amelyek rétegek sokaságára vannak leképezve, és kibontja a leképező jeleket, hogy egy első kódszóhoz való modulálási jeleket és egy második kódszóhoz való modulálási jeleket állítson elő,

azzal jellemezve, hogy amikor a rétegek sokaságának száma nagyobb, mint 4, legalább egy, az első kódszóhoz való modulálási jel és egy, a második kódszóhoz való modulálási jel leképeződik legalább 3 rétegre, és

ahol ha a rétegek sokaságának száma nagyobb, mint 5, az első kódszóhoz való modulálási jelek 2 rétegre, a második kódszóhoz tartozó modulálási jelek pedig a fennmaradó 3 rétegre képeződnek le, és

amikor a rétegek sokaságának száma 6, az első kódszóhoz való modulálási jelek 3 rétegre, a második kódszóhoz tartozó modulálási jelek pedig a fennmaradó 3 rétegre képeződnek le, és

amikor a rétegek sokaságának száma 7, az első kódszóhoz való modulálási jelek 3 rétegre, a második kódszóhoz tartozó modulálási jelek pedig a fennmaradó 4 rétegre képeződnek le, és

amikor a rétegek sokaságának száma 8, az első kódszóhoz való modulálási jelek 4 rétegre, a második kódszóhoz tartozó modulálási jelek pedig a fennmaradó 4 rétegre képeződnek le.

10. A 9. igénypont szerinti vevő, ahol amikor a rétegek sokaságának a száma 5, 6, 7 vagy 8, a leképező jelek kibontódnak az első kódszóhoz való modulálási jelekre és a második kódszóhoz való modulálási jelekre a következő táblázat szerint:

Rétegek sokaságának a száma	Kódszavak száma	Kódszó rétegre való leképezése $i = 0, 1, \dots, M_{\text{symb}}^{\text{layer}} - 1,$ $M_{\text{symb}}^{\text{layer}}$: modulálási jelek száma a rétegek sokaságának minden egyes rétegére
5	2	$x^{(0)}(i) = d^{(0)}(2i)$ $x^{(1)}(i) = d^{(0)}(2i+1)$ $x^{(2)}(i) = d^{(1)}(3i)$ $x^{(3)}(i) = d^{(1)}(3i+1)$ $x^{(4)}(i) = d^{(1)}(3i+2)$ $M_{\text{symb}}^{\text{layer}} = M_{\text{symb}}^{(0)}/2 = M_{\text{symb}}^{(1)}/3$
6	2	$x^{(0)}(i) = d^{(0)}(3i)$ $x^{(1)}(i) = d^{(0)}(3i+1)$ $x^{(2)}(i) = d^{(0)}(3i+2)$ $x^{(3)}(i) = d^{(1)}(3i)$ $x^{(4)}(i) = d^{(1)}(3i+1)$ $x^{(5)}(i) = d^{(1)}(3i+2)$ $M_{\text{symb}}^{\text{layer}} = M_{\text{symb}}^{(0)}/3 = M_{\text{symb}}^{(1)}/3$
7	2	$x^{(0)}(i) = d^{(0)}(3i)$ $x^{(1)}(i) = d^{(0)}(3i+1)$ $x^{(2)}(i) = d^{(0)}(3i+2)$ $x^{(3)}(i) = d^{(1)}(4i)$ $x^{(4)}(i) = d^{(1)}(4i+1)$ $x^{(5)}(i) = d^{(1)}(4i+2)$ $x^{(6)}(i) = d^{(1)}(4i+3)$ $M_{\text{symb}}^{\text{layer}} = M_{\text{symb}}^{(0)}/3 = M_{\text{symb}}^{(1)}/4$
8	2	$x^{(0)}(i) = d^{(0)}(4i)$ $x^{(1)}(i) = d^{(0)}(4i+1)$ $x^{(2)}(i) = d^{(0)}(4i+2)$ $x^{(3)}(i) = d^{(0)}(4i+3)$ $x^{(4)}(i) = d^{(1)}(4i)$ $x^{(5)}(i) = d^{(1)}(4i+1)$ $M_{\text{symb}}^{\text{layer}} = M_{\text{symb}}^{(0)}/4 = M_{\text{symb}}^{(1)}/4$

		$x^{(6)}(i) = d^{(1)}(4i+2)$ $x^{(7)}(j) = d^{(1)}(4i+3)$
--	--	--

ahol a fenti táblázatban $d^{(0)}(i)$ az első kódszóhoz való modulálási jelek, $d^{(1)}(i)$ a második kódszóhoz való modulálási jelek, $x^{(n)}(i)$ az n rétegre leképezett leképezési jelek, $M^{(0)}_{\text{symb}}$ az első kódszóhoz való modulálási jelek száma, $M^{(1)}_{\text{symb}}$ pedig a második kódszóhoz való modulálási jelek száma.