



INTERNATIONAL APPLICATION PUBLISHED UNDER THE PATENT COOPERATION TREATY (PCT)

<p>(51) International Patent Classification ⁶ : G01N 21/00, G01B 11/00, G02B 26/08, G02F 1/33</p>	<p>A1</p>	<p>(11) International Publication Number: WO 96/19722</p>
<p>(21) International Application Number: PCT/US95/04614 (22) International Filing Date: 13 April 1995 (13.04.95) (30) Priority Data: 361,135 21 December 1994 (21.12.94) US (71) Applicant: TENCOR INSTRUMENTS [US/US]; 2400 Charleston Road, Mountain View, CA 94043 (US). (72) Inventor: NIKOONAHAD, Mehrdad; 271 Oakhurst Place, Menlo Park, CA 94025 (US). (74) Agents: HSUE, James, S. et al.; Majestic, Parsons, Siebert & Hsue, Suite 1450, Four Embarcadero Center, San Francisco, CA 94111 (US).</p>		<p>(43) International Publication Date: 27 June 1996 (27.06.96)</p> <p>(81) Designated States: JP, KR, European patent (AT, BE, CH, DE, DK, ES, FR, GB, GR, IE, IT, LU, MC, NL, PT, SE).</p> <p>Published With international search report.</p>

(54) Title: VARIABLE SPOT-SIZE SCANNING APPARATUS

(57) Abstract

An apparatus for both deflecting a beam of light illuminating a spot on a surface and varying the size of the spot, electronically, without changing any system components. The apparatus includes an acousto-optic deflector (10) driven with a linear FM signal produced by a chirp signal generator (16). The linear FM signal is characterized with a dispersion rate, and the chirp signal generator includes a chirp dispersion selector to vary the dispersion rate. A beam of collimated light (13) passes through the acousto-optic deflector (10) and appropriate focusing optics (14, 15) image the beam onto a spot in a nominal focal plane (17). The chirp dispersion selector (17) sets the dispersion rate in accord to a nominal rate, resulting in the beam illuminating a spot (18) in the focal plane (17). Generally, the focal plane coincides with a wafer surface (24), of the type having periodic (27b) and non-periodic (27c) features on it.

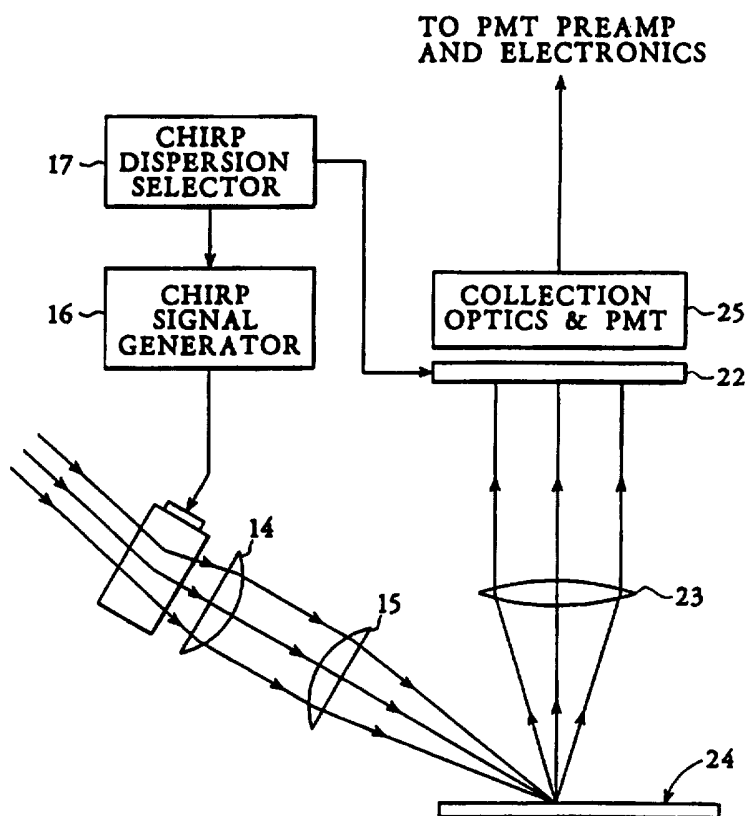

FOR THE PURPOSES OF INFORMATION ONLY

Codes used to identify States party to the PCT on the front pages of pamphlets publishing international applications under the PCT.

AT	Austria	GB	United Kingdom	MR	Mauritania
AU	Australia	GE	Georgia	MW	Malawi
BB	Barbados	GN	Guinea	NE	Niger
BE	Belgium	GR	Greece	NL	Netherlands
BF	Burkina Faso	HU	Hungary	NO	Norway
BG	Bulgaria	IE	Ireland	NZ	New Zealand
BJ	Benin	IT	Italy	PL	Poland
BR	Brazil	JP	Japan	PT	Portugal
BY	Belarus	KE	Kenya	RO	Romania
CA	Canada	KG	Kyrgystan	RU	Russian Federation
CF	Central African Republic	KP	Democratic People's Republic of Korea	SD	Sudan
CG	Congo	KR	Republic of Korea	SE	Sweden
CH	Switzerland	KZ	Kazakhstan	SI	Slovenia
CI	Côte d'Ivoire	LI	Liechtenstein	SK	Slovakia
CM	Cameroon	LK	Sri Lanka	SN	Senegal
CN	China	LU	Luxembourg	TD	Chad
CS	Czechoslovakia	LV	Latvia	TG	Togo
CZ	Czech Republic	MC	Monaco	TJ	Tajikistan
DE	Germany	MD	Republic of Moldova	TT	Trinidad and Tobago
DK	Denmark	MG	Madagascar	UA	Ukraine
ES	Spain	ML	Mali	US	United States of America
FI	Finland	MN	Mongolia	UZ	Uzbekistan
FR	France			VN	Viet Nam
GA	Gabon				

Description

Variable Spot-Size Scanning Apparatus

5 Technical Field

The present invention pertains to the field of semiconductor wafer inspection. Specifically, the present invention pertains to a laser scanner for a semiconductor wafer inspection apparatus.

10

Background Art

Monitoring anomalies during the manufacture of integrated circuits or semiconductor wafers is an important factor to increasing production yields. Numerous types of anomalies, for example, pattern defects and particulate contaminants, can occur on a wafer's surface. Ascertaining the presence, location and type of anomaly can aid in determining both at which step in the process the anomaly occurred and whether a wafer should be discarded.

20

Originally, anomalies were monitored manually by visual inspection of wafer surfaces for the presence of particulate matter. These contaminants, usually dust or microscopic silicon particles, caused many of the defective wafers. However, manual inspection proved time-consuming and unreliable due to operator errors or an operator's inability to observe certain defects. The ever increasing size of the wafer surface, along with the decreasing dimensions of the components thereon, resulted in a sharp increase in the number of components on the wafer's surface. The need for automation became manifest.

25

30

35

To decrease the time required to inspect wafer surfaces, many automatic detection systems were introduced. A substantial majority of these automatic inspection systems detect defects and contamination based on the scattering of light. For example, see U.S. Patent

No. 4,601,576 to L. Galbraith, assigned to the assignee of the present invention.

Another inspection system is disclosed in U.S. Pat. No. 4,912,487 to Porter et al. wherein a system
5 illuminates a target surface with an argon ion laser beam. An acousto-optical deflector is driven with a chirp signal and placed in the path of the beam to cause it to sweep out raster scan lines. The target is placed on a stage capable of bi-directional movement. The beam
10 has an angle of incidence normal to the target and the stage moves so that it is scanned along adjacent contiguous strips of equal width.

In U.S. Pat. No. 4,898,471 to Stonestrom et al., an apparatus and method for detecting particles on a
15 patterned surface is disclosed wherein a single light beam is scanned, at a grazing angle of incidence, across the surface. The surface contains a plurality of identical dies with streets between them. With the beam scanning parallel to the streets, a single channel collection
20 system detects scattered light from an azimuthal angle that maximizes particle signals while reducing pattern signals. A processor constructs templates from the detected light which corresponds to individual dies and then compares the templates to identify particles on the
25 dies.

These aforementioned systems each includes two major components: illumination optics and collection-detection optics. Illumination optics generally consists of a light source producing a beam of
30 light, e.g. a laser, and an apparatus for focusing and scanning the beam. Anomalies present on the wafer's surface scatter incident light. The collection optics detects the scattered light with reference to the known beam position. The scattered light is then converted to
35 electrical impulses which can be measured, counted and displayed as bright spots on an oscilloscope or other monitor.

The sensitivity of the illumination optics is dependent upon the surface of the wafer illuminated. Sensitivity, in this context, is a measure of the signal from an anomaly as compared to the background signal. If
5 the surface illuminated is rough, e.g., a patterned surface, this reduces the sensitivity of the system because such areas produce random scatter which makes it difficult to determine the presence of an anomaly. The random scatter can produce a background signal up to four
10 orders of magnitude larger than the signal from the anomaly. Generally there are two types of patterns: periodic features, e.g. memory arrays, and non-periodic features, e.g. the quasi-random logic, forming a microprocessor.

15 Under laser illumination, the light scattered from periodic features exhibits a periodic diffraction pattern. This diffraction pattern can be removed by an appropriate spatial filter at a Fourier transform plane, resulting in a high signal/background contrast. Based on
20 the theory of Fourier optics, the size of the diffraction spots are inversely proportional to the size of the illumination spot. Therefore, the larger the illumination spot, the more concentrated the power in the diffraction spots, providing more effective spatial filtering to reduce background signals. With respect to
25 periodic regions, it is evident that the larger the illumination spot, the greater the detection sensitivity.

In the case of quasi-random logic, the pattern is non-periodic resulting in a non-periodic intensity
30 distribution at the Fourier transform plane. In this situation, spatial filtering fails to enhance the signal/background contrast. In quasi-random logic area it is desired to use as small a spot size as possible, while maintaining a desirable throughput, to resolve a
35 maximum number of pattern features. To improve the signal/background contrast, periodic feature comparison is employed where adjacent features are compared. On many devices of interest, both array logic and

quasi-random logic are present, resulting in two conflicting requirements for the spot size.

It is an object, therefore, of the present invention to provide a scanning apparatus capable of
5 varying a beam spot size to a plurality of sizes without changing any components of the apparatus.

It is a further object of the present invention to provide a high-speed scanning apparatus that varies a beam spot size during a scan without changing any
10 components in the system.

Disclosure of the Invention

These objects have been achieved with a laser scanner which varies the beam spot size electronically to
15 a plurality of different spot sizes, with one spot size for random logic and another spot size for periodic features. The scanner features an acousto-optic deflector electronically coupled to both a chirp signal generator and a chirp dispersion selector, with the chirp
20 dispersion selector varying a dispersion rate of the chirp signal in accordance with the presence of periodic and non-periodic features on the surface. A laser beam passes through the acousto-optic deflector. A chirp correction lens is positioned to receive the beam exiting
25 the acousto-optic deflector. The beam passing through the chirp correction lens is incident on a scan lens that defines a focal plane. The scan lens is one focal length away from the center of the acousto-optic deflector, thereby providing a telecentric scan on the surface of
30 the wafer.

In operation, the focal plane generally coincides with a wafer surface, of the type having periodic and non-periodic features on it. When the spot illuminates non-periodic features on the surface, the
35 dispersion selector may fix the dispersion of the chirp signal to a nominal rate. For purposes of this invention, a nominal dispersion rate is defined as the dispersion rate which produces a diffraction limited spot

at the focal plane where the surface undergoing inspection is located. When the spot illuminates periodic features, the dispersion selector may vary the dispersion rate from the nominal rate, thereby producing, at the focal plane, a spot with dimensions greater than the dimensions of the diffraction limited spot. The apparatus may operate in two different modes. In a first mode, the size of the spot is fixed throughout the inspection. In a second mode, the size of the spot varies, as it is scanned.

The scanning apparatus can augment an existing wafer inspection. In such a system, the wafer surface, resting on a moveable stage, includes a light source producing a beam directed on a wafer, or the like, at a predefined angle. An acousto-optic deflector is provided to deflect the beam across the surface in a first direction, as a series of lines that are generally normal to the incident beam, while the stage moves in a second direction, perpendicular to the first direction. In this manner the spot scans over the entire surface of the wafer with the light scattering from anomalies present thereon. A suitable light collection system is located so as to optimize the capture of light with optimum contrast between light scattered from the anomalies and that scattered from background.

Brief Description of the Drawings

Fig. 1 is a plan view of the present invention showing different divergence of optical outputs at different chirp rates.

Fig. 2A is a top view of an illuminated spot on a surface having patterned features, traveling along a scan in accord with the present invention.

Fig. 2B is a detailed view of a patterned feature of the type having periodic and non-periodic features.

Fig. 3 is a graphical representation of the field distribution of the spot intensity versus position in accord with the present invention.

Fig. 4 is a plan view of the present invention
5 incorporated into an inspection system.

Best Mode for Carrying Out the Invention

With reference to Fig. 1, an acousto-optic deflector (AOD) 10 having an entrance aperture 11 and an
10 exit aperture 12, opposite the entrance aperture 11 is shown with a beam 13, represented by rays 13a-c, passing through it, from the entrance aperture 11 to the exit aperture 12. The AOD 10 may either be a single axis or a dual axis AOD. In the preferred embodiment, beam 13 is
15 collimated. A chirp correction lens 14 is positioned proximate to the exit aperture 12, to receive the beam exiting the AOD 10. A scan lens 15 is positioned one focal length away from the center of the AOD, measured between the entrance 11 and exit apertures 12, and
20 receives the beam 13 passing through the chirp correction lens 14. In this manner, scan lens 15 provides a telecentric scan at nominal focal plane 17. The distance between said center and the chirp correction lens 14 is only a fraction of said focal length. A chirp signal
25 generator 16 is electronically coupled to the AOD 10. The generator 16 drives the AOD 10 with liner FM rf signals: chirp signals.

Each chirp signal is characterized with a dispersion rate. The dispersion rate of the chirp signal μ ,
30 is defined as:

$$\mu = \frac{B}{T} ,$$

where B and T are the chirp bandwidth and time respectively.
35 The chirp signal induces a variable pitch diffraction grating within the AOD 10 causing the rays within beam 13 to be diffracted at different angles. This decollimates the beam passing through the AOD 10,

causing the beam at the exit aperture 12 to be uncol-
 limated, i.e., either diverging, shown as rays 13d-e, or
 converging (not shown). Assume the beam 13 at the
 entrance aperture 11 is Gaussian in form, at the center
 5 of the AOD, the field is defined as follows:

$$u_1(x_1) = u_0 \exp - \left(\frac{2x_1}{W} \right)^2$$

where $u_1(x_1)$ and W are the field amplitude and the full
 10 width of the beam between the $1/e^2$ points of the intensity
 distribution. The beam at the exit aperture 12 can then
 be characterized as follows:

$$15 \quad u_2(x_2) = u_0 \exp - \left(\frac{2x_1}{W} \right)^2 \text{rect} \left(\frac{x_2}{A} \right) \exp j \left\{ \omega_0 \left(\frac{x_2}{v} \right) + \frac{1}{2} \mu \left(\frac{x_2}{v} \right)^2 \right\}$$

where A is the physical length of the AOD 10 from the
 entrance aperture 12 to the exit aperture 13, ω_0 is the
 center frequency of the chirp signal and v is the acous-
 tic velocity in the AOD 10 crystal. The deflection of
 20 the beam 13 described by $u_2(x_2)$ is defined as the linear
 part of the phase. The quadratic part of the phase
 accounts for the fact that the chirp signal decollimates
 the beam emerging from the AOD, i.e., the beam at the
 exit aperture 12 is either converging or diverging.
 25 The chirp correction lens 14 is chosen so that it
 removes the quadratic phase component of $u_2(x_2)$, thereby
 re-collimating the beam at the exit aperture 12, when the
 dispersion is set at a nominal dispersion rate. To that
 end, the chirp correction lens 14 includes an aspherical
 30 surface, and it is placed very close to the exit aperture
 12, in the manner described above, to reduce the phase
 distortion in $u_2(x_2)$ due to propagation between them and
 to provide a telecentric scan on the scan lens 15.

Referring also to Fig. 2A, at the nominal dis-
 35 persion rate, the scan lens 15 focuses the beam, colli-
 mated by the chirp correction lens 14 having positive
 cylindrical power, into a spot 18 with a small numerical
 aperture, defining a nominal spot size. Changing the

dispersion rate of the chirp signal, from the nominal rate, increases the spot size/dimension, referred to as the variable spot-size (VSS) effect. To change the dispersion rate, the chirp dispersion selector 17 alters
5 either the chirp sweep time T or bandwidth B. Determining which variable to alter is system dependent. In the preferred embodiment, varying the chirp sweep time T is preferred. Adjusting the chirp bandwidth B results in increasing the length of the scan line.

10 Either increasing or reducing the dispersion will provide the VSS effect. For a given slope, increasing the dispersion rate causes the beam at the exit aperture 12 to become more divergent and precludes the chirp correction lens 14 from recollimating the
15 entire beam. In this manner, the beam passing through the scan lens 15 is divergent and comes to a focus at a longer distance from the nominal focal plane 17. This results in a spot size, larger than the nominal spot size, being present at the nominal focal plane 17.
20 Reducing the dispersion rate of the chirp causes the beam at the exit aperture 12 to become less divergent, again precluding the chirp correction lens from recollimating the entire beam. In this manner, the beam entering the scan lens 15 is converging and comes to focus with a
25 nominal spot size at a shorter distance from the nominal focal plane 17. This also results in a spot size, larger than a nominal spot size, being present at the nominal focal plane. If the slope of the chirp were changed, the VSS effect would still be achieved. The beam exiting the
30 AOD, however, would be convergent, requiring a chirp correction lens having negative cylindrical power to recollimate it.

 If a single axis AOD were employed, changing the dispersion rate would change the spot diameter in one
35 direction only: with reference to Fig. 1, the direction would be parallel to the x axis. If a dual axis AOD were employed, changing the dispersion rate would change the spot size in two directions: with reference to Fig. 1,

those directions would be parallel to the x axis and parallel to the y axis.

Fig. 3 is a graphical representation of the VSS effect, showing the intensity distribution at the nominal focal plane. The ordinate, or vertical axis, represents the intensity level of the spot, and the abscissa X represents the position in microns. Assuming the chirp correction lens 14 is a plano-convex lens, the field distribution at the exit aperture of lens 14 is defined as follows:

$$u_3(x_3) = u_2(x_2) \exp \left\{ -j2\pi(n-1) \left(\Delta_0 + R \left(1 - \sqrt{1 - \frac{x_3^2}{R^2}} \right) \right) \right\}$$

where n is the refractive index, R is the radius of curvature of the lens and Δ_0 is the center thickness of the lens. Assuming that the field distribution at the focal plane and $u_3(x_3)$ are Fourier transform pairs, the nominal focal plane distribution is defined as follows:

$$u_4(x_4) = \int_{-\infty}^{\infty} u_3(x_3) \exp \left(\frac{-j2\pi x_4 x_3}{\lambda F} \right) dx_3$$

where λ and F are the wavelength and focal length of the scan lens respectively. It is seen that using $\lambda=488\text{nm}$, $v=0.656 \text{ mm}/\mu\text{s}$, $A=15\text{mm}$, $W=8.1\text{mm}$, $F=120\text{mm}$, $n=1.52238$, $R=675.67\text{mm}$ and the dispersion = $0.68627 \text{ MHz}/\mu\text{s}$, line 20 represents a spot having a size, at the $1/e^2$ points, under 10 microns. Increasing the dispersion to $0.7 \text{ MHz}/\mu\text{s}$ increase the spot size to 27 microns at the $1/e^2$ points, as represented by line 21.

Referring to Fig. 4, shown therein is an optical inspection system for defect and foreign matter detection on a surface including the present invention. The chirp dispersion selector is electronically coupled to a programmable spatial filter 22. The Fourier transform lens 23 is positioned to receive light scattered from the wafer surface 24. In this case, the wafer surface 24 is located at the nominal focal plane defined by scan lens 15. The programmable spatial filter 22 is

-10-

positioned in front of the collection optics 25, which may include a photomultiplier. The collection optics 25 converts the collected light into electrical signals which are further processed by dedicated electronics and finally displayed in various forms, e.g., an image or a template. Although only one collection channel is shown, any number of collection channels may be employed, dependent upon the application.

Referring also to Figs. 2A and 2B, in operation, the topography of the wafer surface 24 is known, either by referencing a map of the surface provided by the manufacturer, or through scanning the surface before inspection. In this manner, the patterned 26 areas of the surface 24 are known. The positions of the periodic 27b and non-periodic 27c features on each die 27a, formed on patterned area 26 are stored in a processor's memory. Generally, a nominal focal plane coincides with the wafer surface 24. The apparatus has at least two modes of operation. In one mode, the dispersion selector fixes the dispersion of the chirp signal in accord with obtaining a desired spot size. In this manner, the dispersion rate of the chirp signal is fixed throughout the entire inspection process of the wafer. For example, if it is desired to inspect for periodic features only, the dispersion selector would be fixed to a dispersion rate that is different from the nominal rate, thereby obtaining a spot size that is larger than a diffraction limited spot size, as described above. This allows inspection by taking advantage of spatial filtering. The entire surface of the wafer would then be scanned so that spot size does not vary during the inspection. If it were desired to detect anomalies in quasi-random logic areas, the dispersion selector would fix the dispersion rate of the chirp signal to the nominal rate. In this manner, periodic feature comparison could be employed. It should be understood that selection of the spot size is not a binary operation. Rather, a range of spot sizes may be obtained by varying the dispersion rate, with the

smallest spot size being diffraction limited, and the largest spot size being system dependent.

In a second mode of operation, the apparatus may vary the spot size during the scan of the wafer. In this manner, the chirp dispersion selector 17 varies the dispersion rate of a chirp signal in accord with the presence of periodic 27b and non-periodic 27c features. When the spot illuminates non-periodic features on the surface, the dispersion selector fixes the dispersion of the chirp signal to a nominal rate. This produces a diffraction limited spot at the nominal focal plane, whereby anomaly detection could be achieved with periodic feature comparison. When the spot illuminates periodic features, the dispersion selector varies the dispersion rate from the nominal rate, thereby producing, at the focal plane, a spot having a size larger than the size of the diffraction limited spot. Contemporaneous with the varying of the dispersion rate, a switch, electronically coupled to the chirp dispersion selector 17, activates the programmable spatial filter 22 when the spot illuminates periodic features, and deactivates the spatial filter when the spot illuminates non-periodic features. In this manner, the system detects anomalies by taking advantage of periodic feature comparison. This enables the spot size to vary as it is scanned by the acousto-optic deflector, without changing any mechanical components or introducing new lenses. The spot size may vary in response to the processor's instruction indicating the topography of the wafer surface 24, e.g., whether periodic or non-periodic features are present, at various points along the scan.

Claims

1. An apparatus for scanning a patterned wafer of the type having periodic and quasi-random features
5 comprising:
 means for providing a beam scanning the surface of a wafer, with a spot; and
 means for varying the dimension of the spot with a first dimension for periodic features and a second
10 dimension for quasi-random features.
2. The apparatus as recited in claim 1 wherein the
15 varying means includes a linear FM signal generator producing a linear FM signal,
 an acousto-optic deflector having an entrance aperture and an exit aperture, opposite the entrance aperture, with the beam passing therethrough, the
20 deflector electronically coupled to the generator to receive the linear FM signal, and
 a chirp dispersion selector, electronically coupled to generator, for changing a dispersion rate of the linear FM signal in accord with the presence of
25 periodic and non-periodic features.
3. The apparatus as recited in claim 2 wherein the
30 acousto-optic deflector is a single axis acousto-optic deflector.
- 35 4. The apparatus as recited in claim 2 wherein the acousto-optic deflector is a dual axis acousto-optic deflector.

5. The apparatus as recited in claim 2 further including a chirp correction lens positioned proximate to the exit aperture, wherein the beam exiting the acousto-optic deflector is characterized by a quadratic phase component defining a phase curvature and the chirp correction lens includes an aspherical surface to remove the phase curvature in the beam exiting the acousto-optic deflector driven by a nominal dispersion rate.

10

6. The apparatus as recited in claim 2 wherein the linear FM signal is characterized with a chirp time and chirp bandwidth and the chirp dispersion selector changes the chirp time in accordance with the spot illuminating periodic features on the surface.

7. The apparatus as recited in claim 2 wherein the linear FM signal is characterized with a chirp time and chirp bandwidth and the chirp dispersion selector changes the chirp bandwidth in accordance with the spot illuminating quasi-random features on the surface.

25

8. An apparatus for deflecting a beam of light illuminating a spot on a surface, of the type having periodic and non-periodic features, comprising:

- an acousto-optic deflector having an entrance aperture and an exit aperture, opposite the entrance aperture,
- a linear FM signal generator electronically coupled to said acousto-optic generator,
- a chirp correction lens positioned proximate to said exit aperture,

means, electronically coupled to said generator, for varying a dispersion rate of a linear FM signal in accord with the presence of periodic and non-periodic features, wherein the beam passes through the acousto-optic deflector from the entrance aperture to the exit aperture, illuminating a spot on the surface with the size of the spot varies in accordance with the dispersion rate.

10

9. The apparatus as recited in claim 8 wherein the acousto-optic deflector is a single axis acousto-optic deflector.

15

10. The apparatus as recited in claim 8 wherein the acousto-optic deflector is a dual axis acousto-optic deflector.

20

11. The apparatus as recited in claim 8 wherein the dispersion rate is characterized with a chirp time and a chirp bandwidth and said varying means varies the chirp time in accordance with the spot illuminating periodic features on the surface.

30

12. The apparatus as recited in claim 8 wherein the dispersion rate is characterized with a chirp time and a chirp bandwidth and said varying means varies the chirp bandwidth in accordance with the spot illuminating periodic features on the surface.

35

13. The apparatus as recited in claim 8 wherein the beam exiting the acousto-optic deflector is characterized by a quadratic phase component defining a phase curvature and the chirp correction lens includes an aspherical surface to remove the phase curvature in the beam exiting the acousto-optic deflector driven by a linear FM signal having a nominal dispersion rate.
14. The apparatus as recited in claim 8 further including a scan lens, defining a focal plane, the scan lens positioned to receive a beam exiting the chirp correction lens, wherein the beam is brought to a diffraction limited focus in the focal plane when the acousto-optic deflector is driven with a linear FM signal having a nominal dispersion rate.
15. The apparatus as recited in claim 14 wherein the chirp correction lens is proximate to the exit aperture, at a distance that is substantially less than the focal length of the scan lens.
16. An optical scanning system for defect and foreign matter detection on a surface comprising:
- means for producing a beam of light,
 - means for directing the beam onto a sample surface of the type having locations with periodic and non-periodic features, producing an illuminated spot,
 - means for scanning the spot across the sample surface,
 - means for varying the spot size in accord with the locations of the periodic and non-periodic features,
 - means for detecting light scattered from the surface which generates a signal representing the light impinging thereon, and
 - means for displaying the signals.

17. The optical scanning system as recited in claim 16 wherein the detecting means is positioned normal to the surface to detect upwardly scattered light.

5

18. The optical scanning system as recited in claim 17 wherein the detecting means includes a programmable spatial filter and further including a means, in
10 electrical communication with the spatial filter, for activating the spatial filter in accord with the spot illuminating periodic features.

15

19. The optical scanning system as recited in claim 16 wherein the means for varying the spot size includes an acousto-optic deflector having an entrance and an exit aperture, electronically coupled to both a linear FM
20 signal generator and a chirp dispersion selector, wherein the beam passes through the acousto-optic deflector from the entrance aperture to the exit aperture, and the acousto-optic deflector is driven with a linear FM signal, produced by the generator and characterized by a
25 dispersion rate, the dispersion rate is varied from a nominal rate, by the chirp dispersion selector, in accord with the spot illuminating periodic features to increase the size of the spot and the dispersion is fixed at the nominal rate in accord with the spot illuminating
30 non-periodic features to maintain a nominal spot size.

20. The optical scanning system as recited in claim 19
35 wherein the means for varying the spot size further comprises a chirp correction lens to collimate a beam exiting the acousto-optic deflector.

21. The optical scanning system as recited in claim 20 wherein the beam exiting the acousto-optic deflector is characterized by a quadratic phase component defining a phase curvature and the chirp correction lens includes an aspherical surface which removes the phase curvature in the beam exiting the acousto-optic deflector driven by a linear FM signal having a nominal dispersion rate.

22. The optical scanning system as recited in claim 20 wherein the dispersion rate is characterized with a chirp time and a chirp bandwidth and the dispersion selector varies the chirp time in accordance with the spot illuminating periodic features on the surface.

23. The optical scanning system as recited in claim 20 wherein the dispersion rate is characterized with a chirp time and a chirp bandwidth and the dispersion selector varies the chirp bandwidth in accordance with the spot illuminating periodic features on the surface.

24. The optical scanning system as recited in claim 20 further including a scan lens, defining a focal plane coinciding with the surface, the scan lens positioned to receive a beam exiting the chirp correction lens, wherein the beam is brought to a diffraction limited focus in the focal plane in accord with illuminating non-periodic features at the focal plane.

25. The optical scanning system as recited in claim 24 wherein the chirp correction lens is proximate to the exit aperture, at a distance that is substantially less than the focal length of the scan lens.

26. A method for scanning a patterned wafer of the type having periodic and quasi-random features comprising:

providing a beam scanning the surface of a wafer with a spot, and

5 varying the dimension of the spot with a first dimension for periodic features and a second dimension for quasi-random features.

10

27. The method as recited in claim 26 wherein the dimension of the spot is varied electronically.

15

28. A method for varying a size of a spot produced by a beam of light illuminating a surface of the type having periodic and non-periodic features comprising the steps of:

20 providing an acousto-optic deflector, a chirp correction lens, positioned to receive a beam of light exiting the deflector, and a scan lens, positioned to receive a beam of light exiting the chirp correction lens,

25 driving the acousto-optic deflector with a linear FM signal, and

varying a dispersion rate of the linear FM signal.

30

29. The method as recited in claim 28 wherein the varying step includes varying a dispersion time.

35

30. The method as recited in claim 28 wherein the varying step includes varying a dispersion bandwidth.

31. The method as recited in claim 28 wherein the beam
exiting the acousto-optic deflector includes a quadratic
phase component and further including the step of
removing the quadratic component of the beam exiting the
5 deflector.

10

15

20

25

30

35

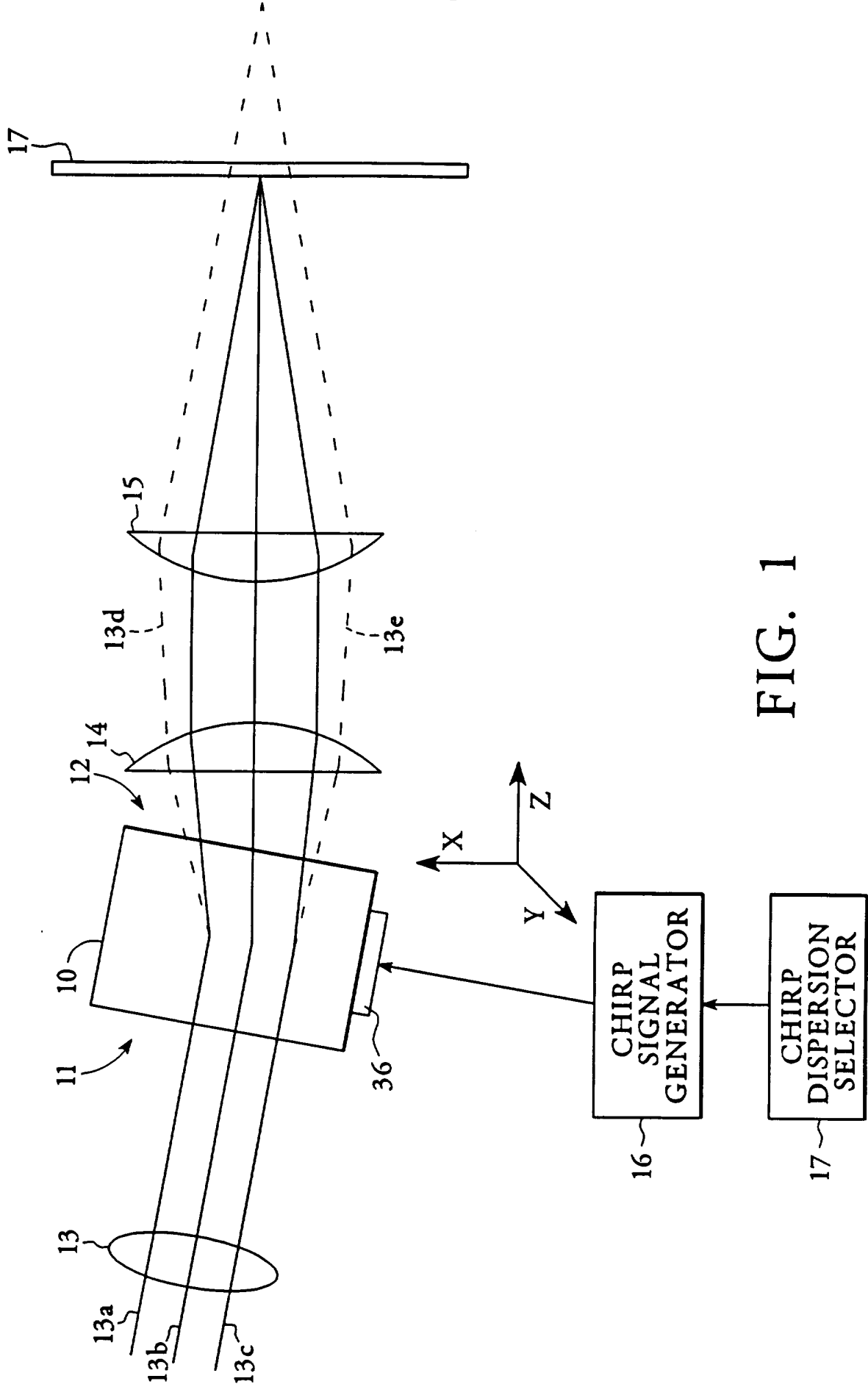

FIG. 1

2/3

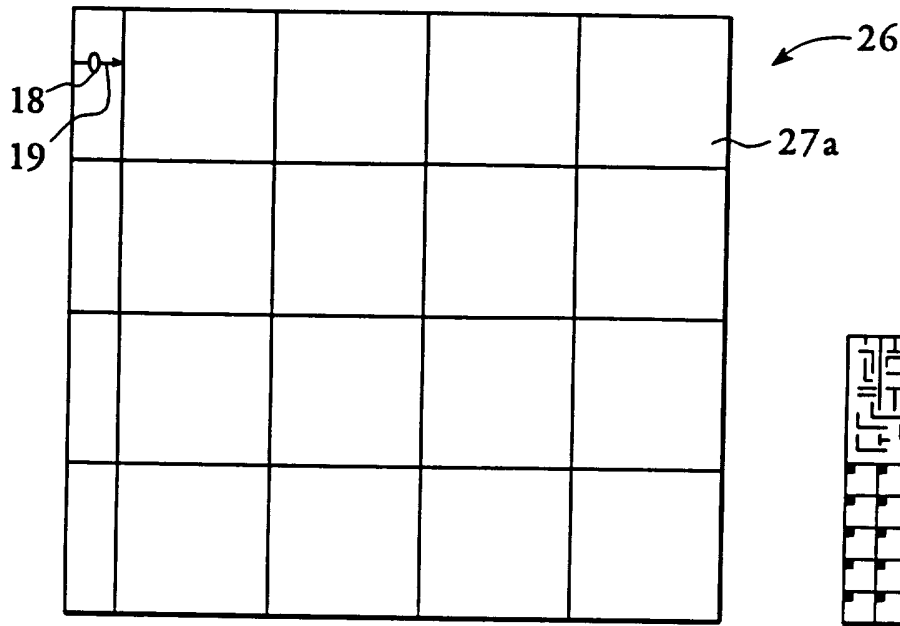

FIG. 2A

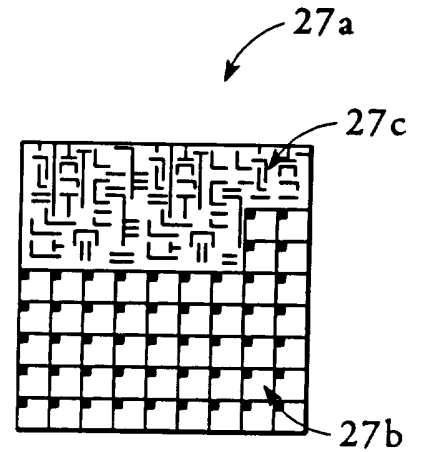

FIG. 2B

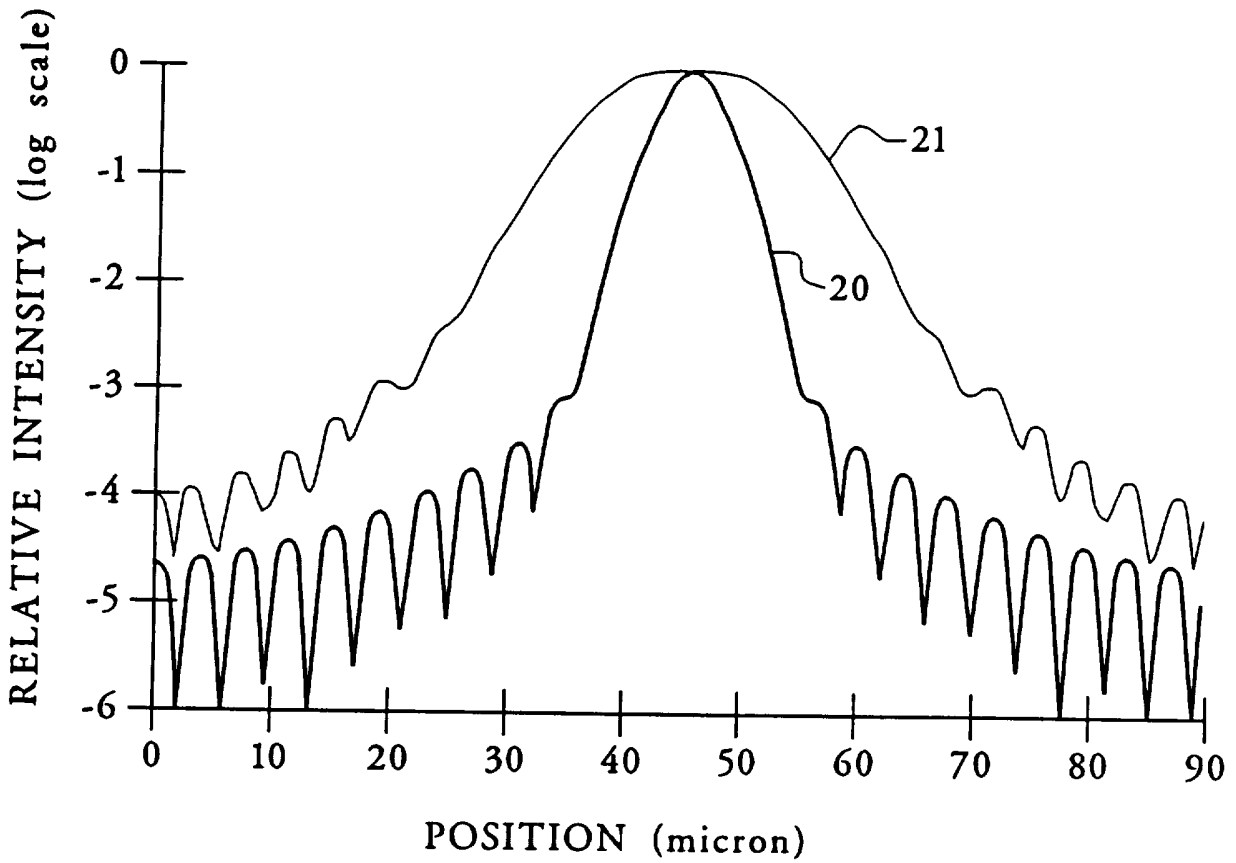

FIG. 3

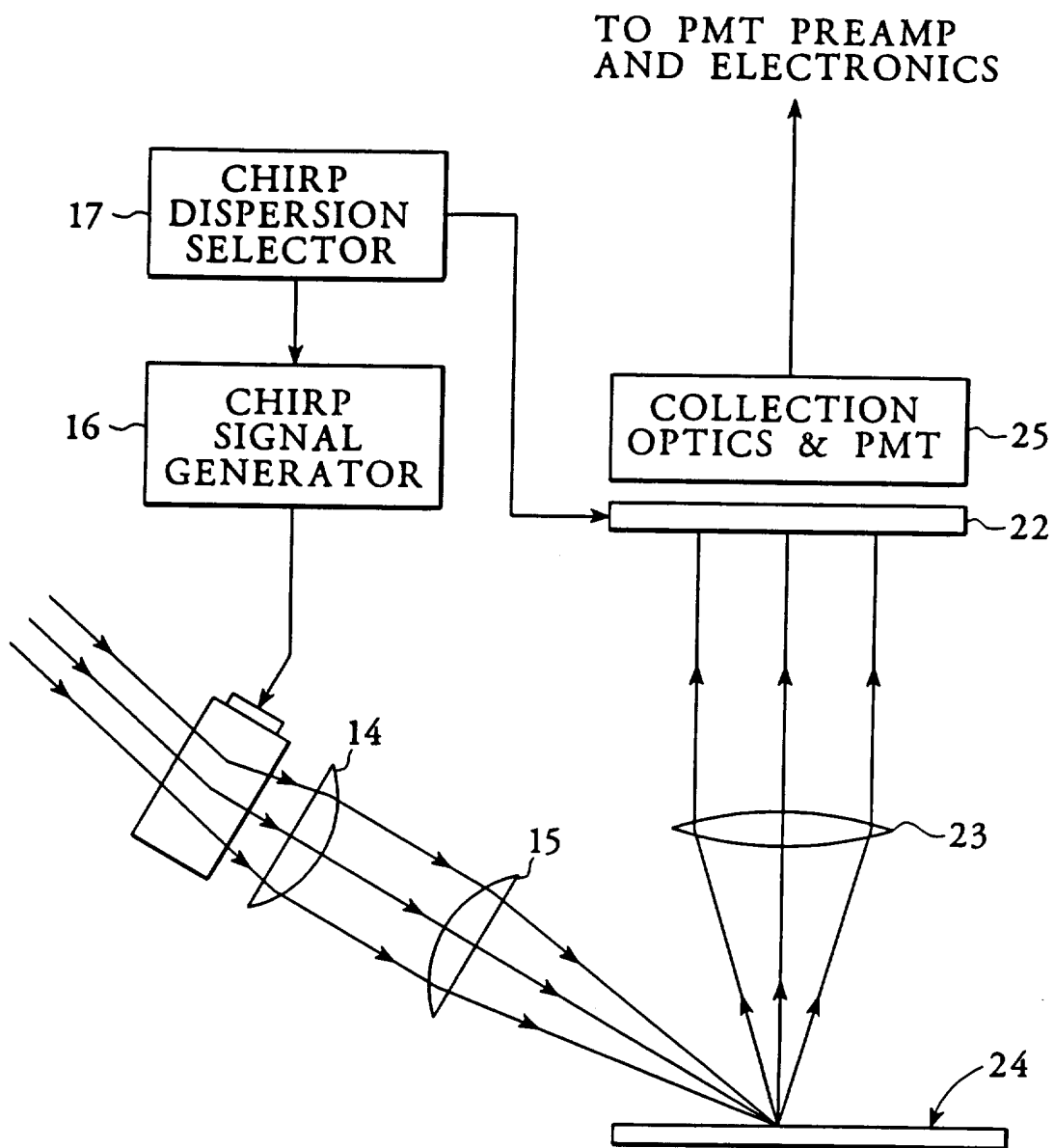

FIG. 4

INTERNATIONAL SEARCH REPORT

International application No.
PCT/US95/04614

A. CLASSIFICATION OF SUBJECT MATTER

IPC(6) :G01N 21/00; G01B 11/00; G02B 26/08; G02F 1/33
US CL :356/237, 394, 338, 398, 431; 250/563, 572; 359/298, 305

According to International Patent Classification (IPC) or to both national classification and IPC

B. FIELDS SEARCHED

Minimum documentation searched (classification system followed by classification symbols)

U.S. : 356/237, 394, 338, 398, 431; 250/563, 572; 359/298, 305

Documentation searched other than minimum documentation to the extent that such documents are included in the fields searched

Electronic data base consulted during the international search (name of data base and, where practicable, search terms used)

C. DOCUMENTS CONSIDERED TO BE RELEVANT

Category*	Citation of document, with indication, where appropriate, of the relevant passages	Relevant to claim No.
Y	US, A, 4,441,124 (HEEBHER ET AL) 03 April 1984, figures 1 and 2.	1-31
Y	US, A, 4,218,142 (KRYGER ET AL) 19 August 1980, figure 1.	1-31
Y	US, A, 4,898,471 (STONESTROM ET AL) 06 February 1990, figure 1.	1-31

Further documents are listed in the continuation of Box C. See patent family annex.

* Special categories of cited documents:	"T"	later document published after the international filing date or priority date and not in conflict with the application but cited to understand the principle or theory underlying the invention
"A" document defining the general state of the art which is not considered to be of particular relevance	"X"	document of particular relevance; the claimed invention cannot be considered novel or cannot be considered to involve an inventive step when the document is taken alone
"E" earlier document published on or after the international filing date	"Y"	document of particular relevance; the claimed invention cannot be considered to involve an inventive step when the document is combined with one or more other such documents, such combination being obvious to a person skilled in the art
"L" document which may throw doubts on priority claim(s) or which is cited to establish the publication date of another citation or other special reason (as specified)	"&"	document member of the same patent family
"O" document referring to an oral disclosure, use, exhibition or other means		
"P" document published prior to the international filing date but later than the priority date claimed		

Date of the actual completion of the international search 20 JULY 1995	Date of mailing of the international search report 31 JUL 1995
---	--

Name and mailing address of the ISA/US Commissioner of Patents and Trademarks Box PCT Washington, D.C. 20231 Facsimile No. N/A	Authorized officer HOA PHAM <i>[Signature]</i> Telephone No. (703) 308-4808
--	---