

(No Model.)

2 Sheets—Sheet 1.

E. J. ENGMAN.  
LEVEE AND DITCHING MACHINE.

No. 379,864.

Patented Mar. 20, 1888.

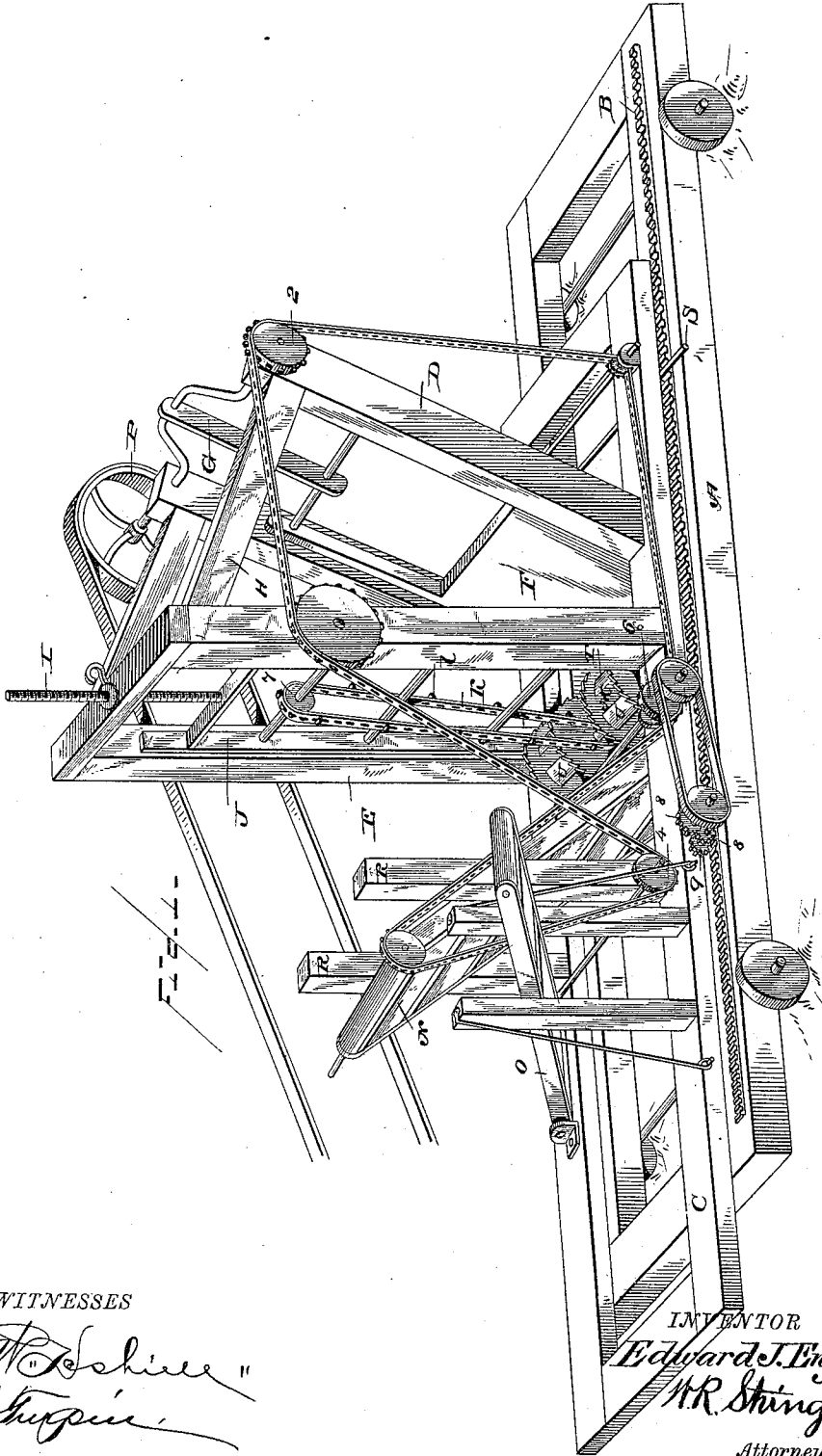

WITNESSES

*W. Schire*  
*H. Turpin*

INVENTOR

*Edward J. Engman.*  
*H. R. Stringfellow*  
Attorney

(No Model.)

2 Sheets—Sheet 2.

E. J. ENGMAN.

LEVEE AND DITCHING MACHINE.

No. 379,864.

Patented Mar. 20, 1888.

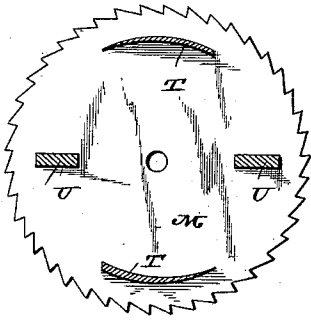

Fig. 2.

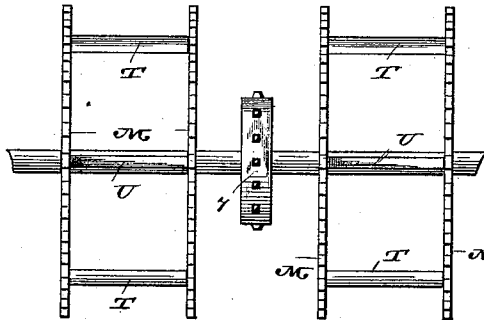

Fig. 3.

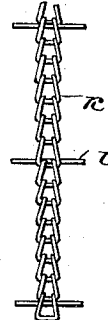

Fig. 4.

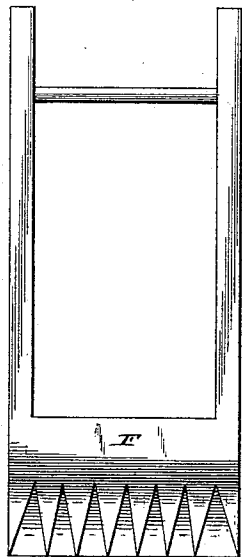

Fig. 5.

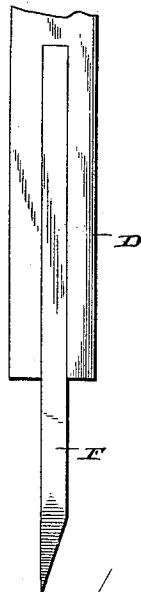

Fig. 6.

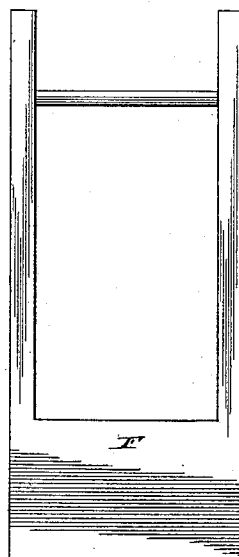

Fig. 7.

WITNESSES

*James Sheehy*

Edward J. Engman,  
INVENTOR,

By *A. R. Stringfellow*,  
Attorney.

# UNITED STATES PATENT OFFICE.

EDWARD JOHN ENGMAN, OF CONCESSION, LOUISIANA.

## LEVEE AND DITCHING MACHINE.

SPECIFICATION forming part of Letters Patent No. 379,864, dated March 20, 1888.

Application filed November 25, 1887. Serial No. 256,084. (No model.)

To all whom it may concern:

Be it known that I, EDWARD JOHN ENGMAN, a citizen of the United States, residing at Concession, in the parish of Plaquemine and State of Louisiana, have invented certain new and useful Improvements in a Levee and Ditching Machine; and I do declare the following to be a full, clear, and exact description of the invention, such as will enable others skilled in the art to which it appertains to make and use the same.

My invention relates to improvements in a levee and ditching machine in which a car with track thereon is made to operate in conjunction with a traveling frame, the latter provided with a spade, in combination with circular saws, knives, and elevators; and the objects of my improvement are to render it possible to construct levees and ditches by steam-power, thereby saving time and labor. I attain these objects by the mechanism illustrated in the accompanying drawings, in which—

Figure 1 is a perspective view. Fig. 2 is a sectional side view of saw. Fig. 3 is a front view of saws. Fig. 4 is a view of chain with buckets thereon. Fig. 5 is a rear view of spade. Fig. 6 is a side sectional view of spade. Fig. 7 is a front view of spade.

Similar letters refer to similar parts throughout the several views.

In constructing my machine I first place a frame on wheels, as shown by A, being of any desired length or width, but prefer the latter to be not less than six feet. On the top of each of the side timbers I place a metal track, B, which is corrugated, and upon which I place traveling frame C, which is provided with cog-wheels 9, which operate in conjunction with wheels 8 for propelling C forward or backward.

D are pieces of timber which are placed on an incline, and which is connected to frame E by arm H, and which holds spade F in position and enables same to be raised or lowered by crank G.

I is a screw for raising or lowering saws, J being metal frame to which shaft upon saws is attached; K, a chain with buckets L thereon.

M are saws.

N is an elevator for raising soil.

P is a driving-wheel.

1 1 are wheels with belt for moving C back and forth.

2, 3, 4, 5, and 6 are sprocket-wheels which

operate in conjunction with chain passing over same.

7 is a sprocket-wheel over which endless chain K passes.

R are posts placed in a vertical position and attached to C, and between which is situated elevator N, with a slot on side of posts for changing position of N.

S is a metal rod resting on B, and which may be shifted as desired.

T are knives placed between saws.

U are metal blocks between saws.

In operating my device force is applied to the driving-wheel, which is connected with an engine, causing spade G to ascend and descend, cutting the soil, say, three feet in width, and by revolution of saws M soil is again cut, when knives again cut same, and metal blocks prevent soil from clogging between saws and knives, while elevator K, by means of buckets L, loosens and lifts up soil which would otherwise cause a choking or clogging of soil at 7; at same time soil is thrown on buckets of elevator N, ascends, and falls on elevator O, and is dumped on one side of machine. After cutting, say, an entire length of car of my machine, say three feet in width, frame C can be shifted on opposite side of A by the usual method, and made to cut an additional width of three feet, thereby enabling a ditch of six feet in width to be obtained, and the soil so removed can be used in building a levee.

Having described my invention, what I claim, and desire to secure by Letters Patent of the United States, is—

1. In a levee and ditching machine such as described, the saws M, knives T, and blocks U, in combination with upright frame E, adjustable frame J, adjusting-screw I, and frames A and C, for the purpose set forth.

2. In a levee and ditching machine such as described, elevator K and wheels 7, in combination with saws M, knives T, and frames A and C, for the purpose set forth.

3. In a levee and ditching machine such as described, elevators N and O, in combination with saws M, blocks U, knives T, and spade F, for the purpose set forth.

In testimony whereof I affix my signature in presence of two witnesses.

EDWARD JOHN ENGMAN.

Witnesses:

HENRY J. RHODES,

PERCY D. PARKS.