

N. BURR.  
STAVE MACHINE.

No. 524,308.

Patented Aug. 14, 1894.

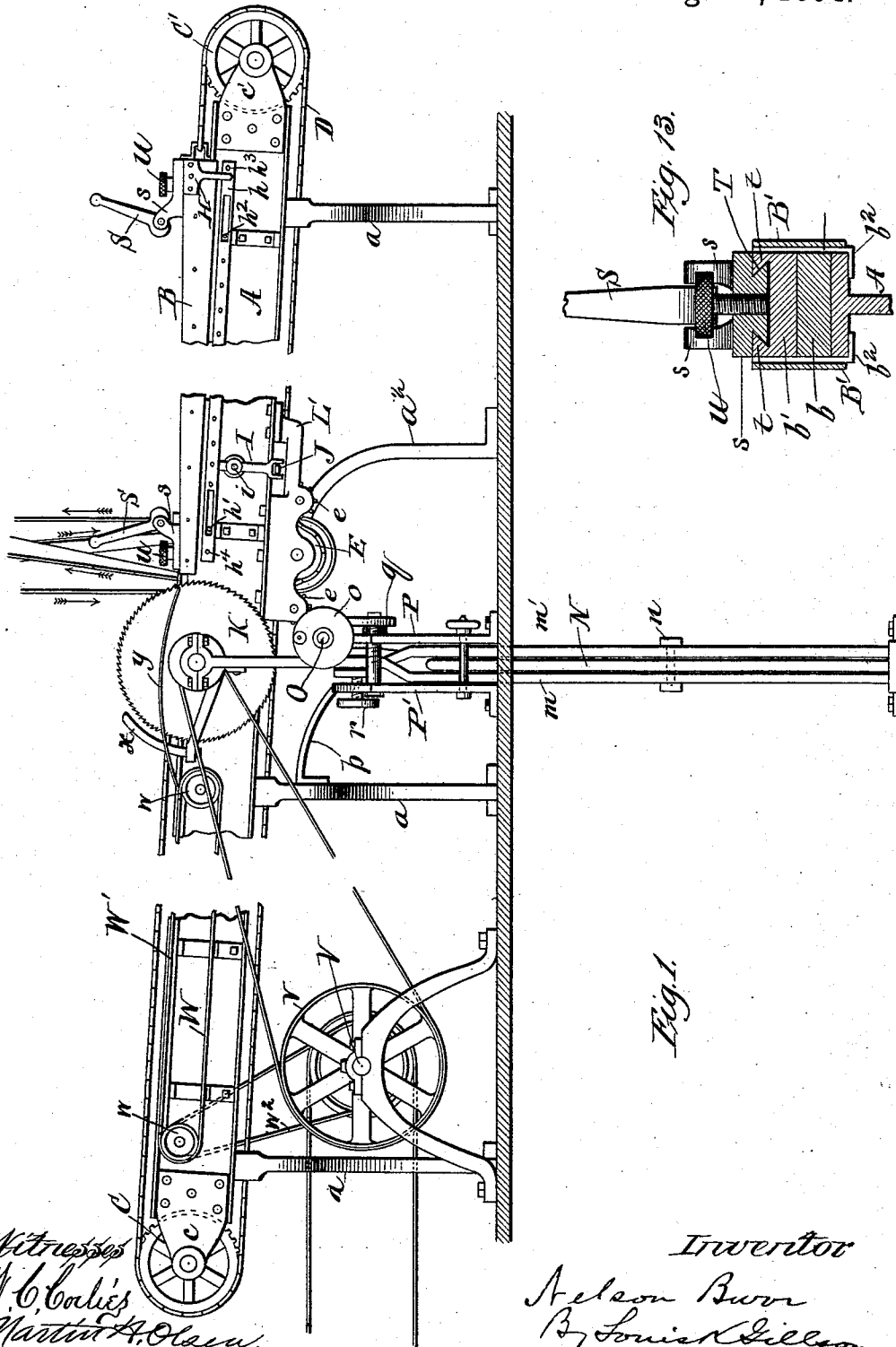

Witnesses  
W. C. Coates  
Martin H. Olm.

Inventor  
Nelson Burr  
By Louis Gillson  
His Attorney.

(No Model.)

4 Sheets—Sheet 2.

# N. BURR. STAVE MACHINE.

No. 524,308.

Patented Aug. 14, 1894.

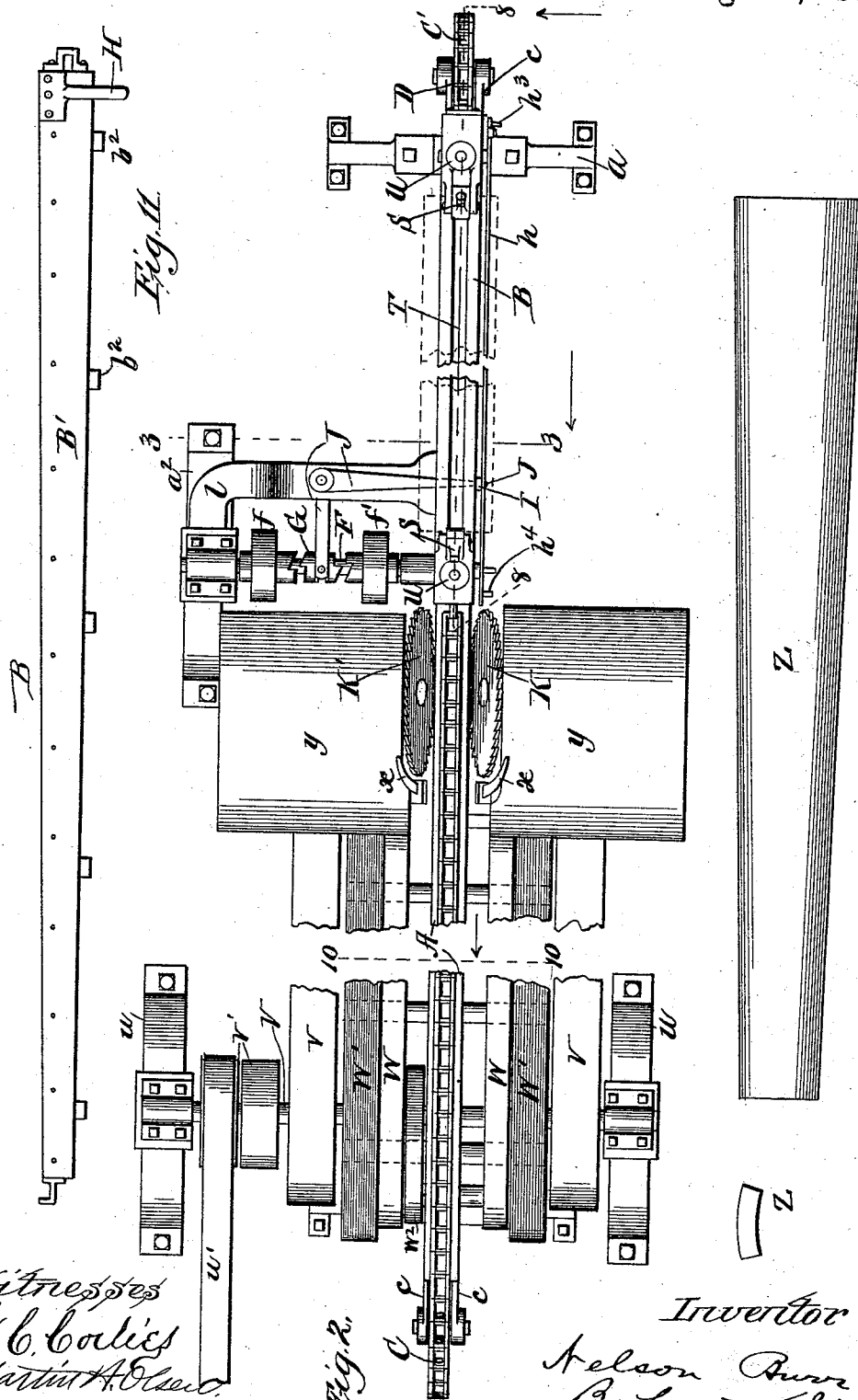

Witnesses  
 W. C. Cortis  
 Martin A. Olson

Fig. 2.

Inventor  
 Nelson Burr  
 By Louis Gillson  
 His Attorney.

# N. BURR. STAVE MACHINE.

No. 524,308.

Patented Aug. 14, 1894.

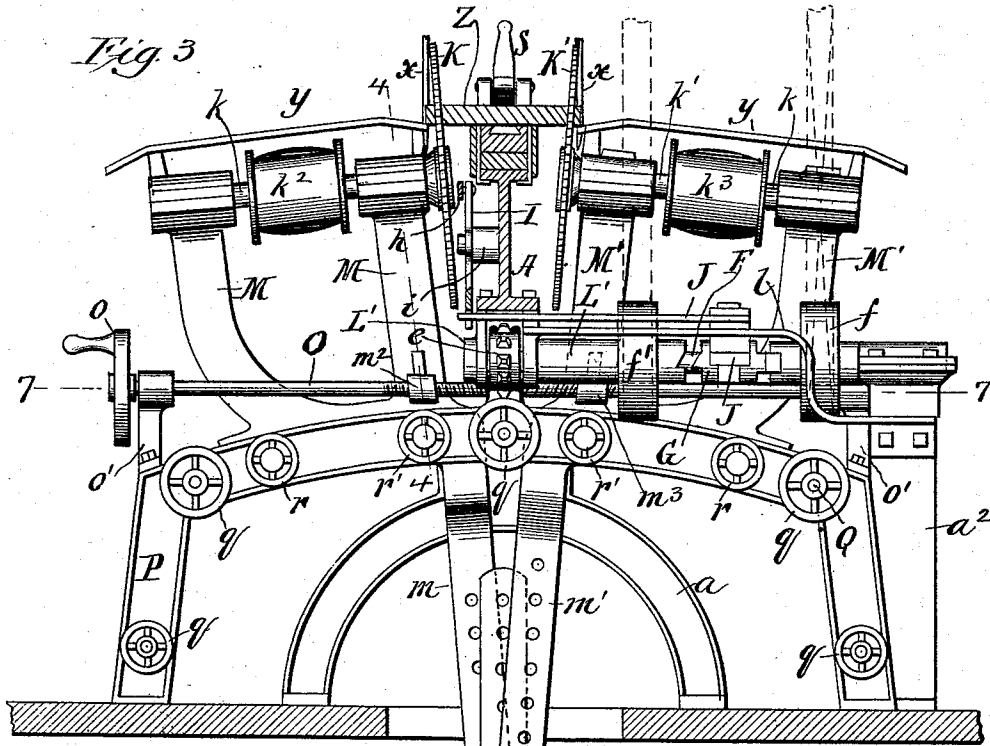
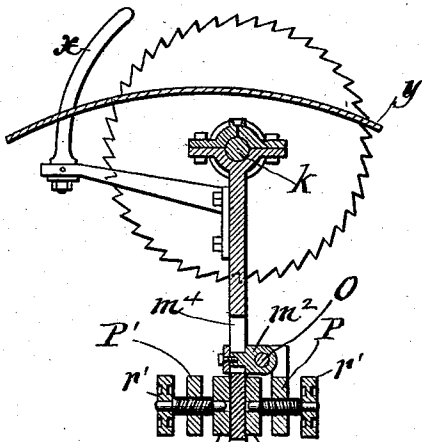

Fig. 4.



Witnesses  
 W. C. Collier  
 Martin A. Olsen

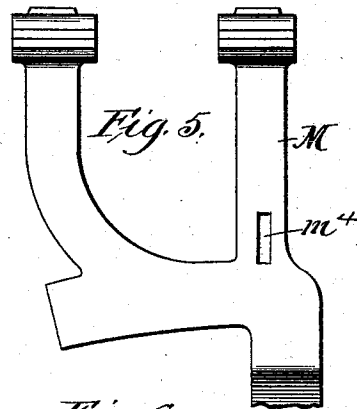
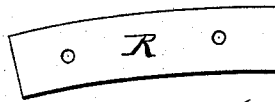

Fig. 6.



Inventor  
 Nelson Burr  
 By Louis K. Gellson  
 His attorney.

N. BURR.  
STAVE MACHINE.

No. 524,308.

Patented Aug. 14, 1894.

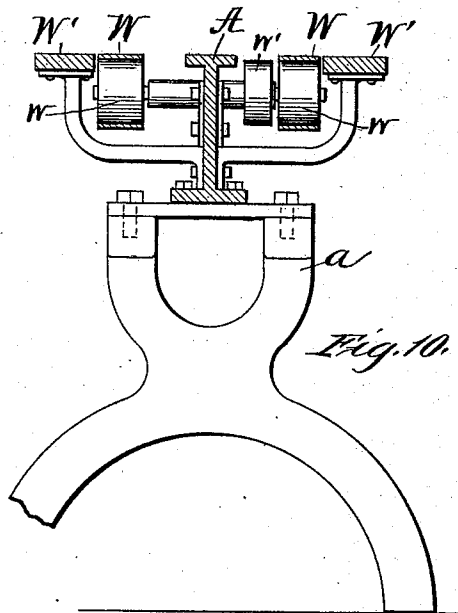
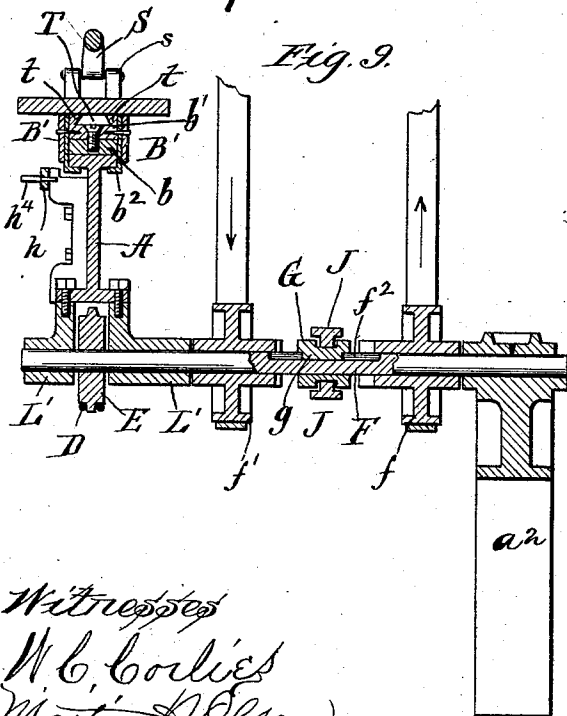
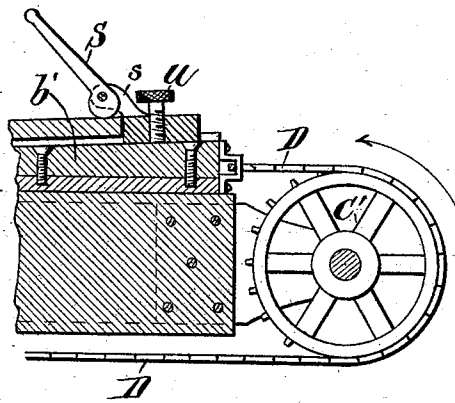
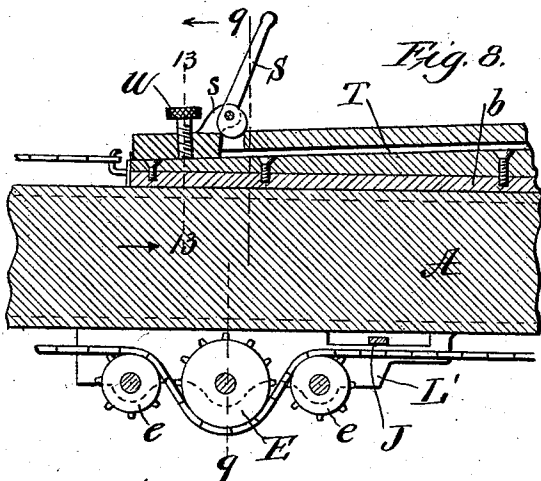
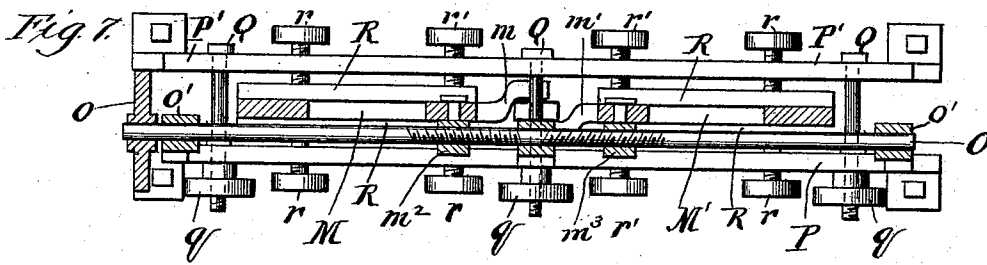

Witnesses  
 W. C. Corlies  
 Martin A. Olsen.

Inventor  
 Nelson Burr  
 By Louis H. Gleson  
 His Attorney.

# UNITED STATES PATENT OFFICE.

NELSON BURR, OF BATAVIA, ILLINOIS.

## STAVE-MACHINE.

SPECIFICATION forming part of Letters Patent No. 524,308, dated August 14, 1894.

Application filed October 8, 1892. Serial No. 448,206. (No model.)

*To all whom it may concern:*

Be it known that I, NELSON BURR, a citizen of the United States, residing at Batavia, in the county of Kane and State of Illinois, have invented certain new and useful Improvements in Stave-Machines; and I do declare the following to be a full, clear, and exact description of the invention, such as will enable others skilled in the art to which it appertains to make and use the same, reference being had to the accompanying drawings, and to the letters of reference marked thereon, which form a part of this specification.

My invention relates to machines for cutting tank staves, and consists of the various parts and arrangement of parts as hereinafter set forth, comprising a machine adapted to complete in one operation the cutting of a stave with both the proper bevel to its edges, and taper of form.

In the accompanying drawings, Figure 1 represents a side elevation of the machine. Fig. 2 is a plan view of the same. Fig. 3 is a vertical cross section on the line 3, 3, of Fig. 2. Fig. 4 is a vertical longitudinal section on the line 4, 4, of Fig. 3. Fig. 5 is a detail of one of the frames for carrying the saws. Fig. 6 is a detail of the saw adjusting device. Fig. 7 is a plan section on the line 7, 7, of Fig. 3. Fig. 8 is a longitudinal section on the line 8—8 of Fig. 2. Fig. 9 is a vertical cross section on the line 9, 9, of Fig. 8. Fig. 10 is a vertical cross section on the line 10, 10, of Fig. 2. Fig. 11 is a side elevation of the carriage. Fig. 12 shows side and end elevations of the product of the machine; and Fig. 13 is an end view of the clamping device for securing the board in the machine.

I use a pair of circular saws K, K', mounted upon arbors journaled in moving frames which swing transversely to the plane of the saws, and from a common center below the machine, the saws being so mounted upon the frames that they lie upon radii of a circle whose center is the pivotal point of the frames, and upon whose circumference the board to be cut lies when adjusted to the carriage B. This imaginary circle is identical in diameter with the tank in which the stave is to be used, so that the angle of the saws is exactly such as to cut the required bevel upon both edges of the stave for use in the tank in view. The

carriage B, upon which the board is fixed is higher at its rearward than at its forward end, so that as the stave advances it is elevated with relation to the saws and consequently gradually widened. The variation in the height of the carriage is such as to produce staves having the required taper for use in the tank in process of construction.

The table or bed of the machine consists of a metal I-beam A, mounted upon standards *a, a, a*. The upper flange of the beam is dressed to form a smooth sliding surface or way for the carriage B, which is mounted upon it.

The carriage is of less width than staves are ever made and may be formed of two strips of wood or iron *b, b'*, placed one above the other, one of them being in tapering form so that the rearward end of the carriage is considerably higher than its forward end, or a series of blocks may be substituted for the lower strip.

The carriage is held to its seat by guide lugs *b<sup>2</sup>*, fixed to its sides and engaged under the flange of the beam A. Dust guards B, B', are fastened to the sides of the carriage and depend below the top of the beam flange.

The top of the carriage is provided with a longitudinal, internally enlarged channel T. The board Z, to be operated upon is placed longitudinally upon the top of the carriage B, and is secured in its place by means of the two cam-clamps S, adapted to engage its ends and which are pivoted to the sliding blocks *s*, which are provided with tenons conforming to and adapted to slide within the channel T. Set screws U, U, pass through the blocks *s*, and their tenons so as to bear against the bottom of the channel T, and lock the blocks in any desired position.

A chain D, has its ends fastened to the ends of the carriage B, and is carried over vertical sprocket sheaves C, C', which are journaled in brackets *c, c'*, projecting from the ends of the beam A, and under the sprocket wheel E, to which power is applied as hereinafter described. The chain is held in engagement with this wheel E, by means of the idle sprocket wheels *e, e*, over which it passes. The wheels E, *e, e*, are mounted upon shafts which are journaled in brackets L', bolted to the lower flange of the beam A. The shaft

F, of the wheel E, is extended some distance beyond the side of the machine and its outer end is journaled in a standard  $a^2$ . Two pulleys  $f, f'$ , are mounted loosely upon the shaft 5 F, and are driven in opposite directions by belts from the line shaft. A clutch G, is mounted upon the shaft F, and adapted to reciprocate between the hubs of the pulleys  $f, f'$ , and to firmly engage either when in 10 contact with it. The shaft F, is formed with a longitudinal groove  $f^2$ , along the path upon which the clutch G, is adapted to slide, and the clutch is provided with an inwardly projecting feather  $g$ , adapted to engage said 15 groove, so that when the clutch is in contact with either of the pulleys, the shaft F, is rotated.

The clutch G, is shifted by means of a bell-crank lever J, one arm of which is forked so 20 as to straddle the clutch, its fork being provided with inwardly projecting studs adapted to engage an annular groove in the clutch. The lever J, is pivoted to the cross arm  $l$ , which extends from the standard  $a^2$ , to the 25 beam A. The free end of the bell-crank lever J, projects under and beyond the beam A, and is engaged by a forked swinging lever I, pivoted to the side of the beam A, at  $i$ .

A shifting bar  $h$ , is located upon the side 30 of the beam A, directly below the path of the carriage B, and is hung upon studs  $h', h^2$ , fixed in the side of the beam and projecting through longitudinal slots in the bar  $h$ . This bar is provided with a pair of movable stop 35 pins  $h^3, h^4$ , which project outwardly so as to be engaged by the downwardly projecting finger H fixed to the carriage B. Contact of the finger H, with either of the pins  $h^3, h^4$ , moves the bar  $h$ , upon the studs  $h', h^2$ .

The upper end of the swinging lever I, is pivotally attached to the bar  $h$ , so that the longitudinal movement of the latter vibrates the lever, thereby moving the free arm of the bell-crank lever J, and shifting the clutch G. 40

It is obvious that connection between the shifting bar  $h$ , and the clutch G, may be secured by various arrangements of the levers I, J, without departing from the scope of the invention the essential feature being such a 45 co-operation between these parts that contact of the finger H, with either of the stop pins  $h^3, h^4$ , shifts the clutch from one pulley to the other.

By the mechanism described the carriage 55 B, is given a reciprocating movement, and the distance of its travel is regulated by the adjustment of the pins  $h^3, h^4$ ,—the bar  $h$ , being provided with any desired number of holes into which they may be set. The movement 60 of the carriage may thus be regulated to correspond with the length of staves being cut.

The circular saws K, K', are located upon opposite sides of the beam A, so that the carriage B, moves between them. The arbors 65 of the saws are journaled in boxes upon the upper ends of the arms of U-shaped frames M, M'. These frames are carried by rigid

supporting bars  $m, m'$ , which project downwardly through the floor upon which the machine rests, to as great a distance as may be 70 required, and are pivotally secured to a fixed post N, by the pin  $n$ . The bars  $m, m'$ , and the post N, are each provided with a longitudinal series of holes adapted to receive the pin  $n$ , so that the pivotal point of the bars 75  $m, m'$ , may be shifted as desired.

The saws K, K', are so mounted upon the frames M, M', as to be in alignment with the series of holes in the supporting bars of their 80 respective frames, so that in whatever position the pivot pin  $n$ , may be placed, each of the saws is upon a radius of a circle of which this pin is the center.

The lower ends of the bars  $m, m'$ , move between two guide flanges  $n'$ , (only one of which 85 is shown) so as to prevent lateral movement.

The frames M, M', are adjusted so as to adapt the machine to use upon staves of a certain width, and held in that position by means of the clamping frames P, P', which 90 are located transversely to the machine, and are bolted to the floor. One of the frames is also braced to the nearest standard  $a$ , as shown at  $p$ . These clamping frames are secured together by bolts Q, as many in number 95 as may be desired, upon the screw threaded ends of which are mounted the lever—or wheel-nuts  $q$ . The height of the clamping frames P, P', is such that the lower portion 100 of the U of each of the frames M, M', lies between them, and is engaged by the contact plates R, R,—four in number, one upon each side of each of the frames M, M'.

The contact plates R, R, are supported upon the inner ends of set screws  $r, r'$ , located 105 in the clamping frames—sockets being provided in the plates for the insertion of the ends of these screws. The principal function of the contact plates R, R, is the adjustment of the saws K, K', in proper alignment. The 110 relative adjustment of the two saws is controlled by a rod O, extending across the machine, and being journaled in brackets  $o'$ , projecting upwardly from the clamping frame 115 P. The rod O, is provided with right and left screw threads to engage the apertured blocks  $m^2, m^3$ , which are secured respectively to the frames M, M', by bolts passing through the vertical slots  $m^4$ , in said frames. The rod O, 120 is provided at one of its ends with a crank arm

$o$ . Power is applied to the saws by means of pulleys  $k^2, k^3$ , keyed to the arbors  $k, k'$ , between the arms of the frames M, M'. Dust shields, Y, Y, are located immediately above 125 the purpose of supporting the strips cut from the edges of the stave until they are engaged by upwardly projecting fingers  $x, x$ , immediately beyond the saws and thereby deflected away from the saws as they are elevated by 130 the forward movement of the carriage, and thrown upon the belts W, W, which run upon the pulleys  $w, w'$ , at each side of the beam, and carried to a suitable dumping place.

I show at  $u, u$ , standards bolted to the floor and provided with journal boxes for carrying the shaft V, upon which are mounted a pair of pulleys  $v'$  one of which is keyed and the other loose, which pulleys are driven by the belt  $u'$ , which transmits power from the line shaft. Belts  $v, v$ , are carried by pulleys keyed upon the shaft V, and drive the pulleys  $k^2, k^3$ . The belts W, W, are also driven by power transmitted from the shaft V, by the belt  $w^2$ , and pulley  $w$ .

Guard rails  $W', W'$ , are located outside of the carrying belts W, W.

In order to leave the edges of the stave smooth and ready for use without further dressing, it is necessary to avoid contact with the rearward edges of the saws. This result is secured by such a relative arrangement of the table or carriage-way and of the supports for the saws that the direction of the movement of the board is oblique to lines from the centers of the saws to the pivotal points of their frames, the board being carried away from the center upon which these frames swing as it advances beyond the cutting edges of the saws. I prefer to accomplish this by inclining the carriage-way upwardly. The standards  $a, a, a$ , are therefore, not of uniform height, so that the forward end of the table or bed is lower than its rearward end, and the carriage is elevated as it advances. By this means the stave passes the rearward edges of the saws at such an elevation that the distance between them is greater than its width.

I claim—

1. In a stave machine the combination with a table or bed whose upper surface inclines upwardly from front to rear, of a carriage adapted to reciprocate upon the table, and a pair of circular saws located upon opposite sides of the table and mounted obliquely so as to flare apart upwardly, substantially as described and for the purpose set forth.

2. In a stave machine the combination with a table or bed whose upper surface inclines upwardly from front to rear, of a carriage

adapted to reciprocate upon the table, a pair of circular saws located upon opposite sides of the table and mounted obliquely so as to flare upwardly, and upwardly projecting fingers at the rear of the saws for deflecting the strips cut from the sides of the stave, substantially as described.

3. In a stave machine the combination with a table or bed and with a carriage tapering upwardly toward its rearward end and adapted to reciprocate upon the table, of a pair of circular saws located upon opposite sides of the table, laterally swinging frames for carrying the saws, and a pair of clamping frames transverse to the table and upon opposite sides of the saw frames and means for drawing said clamping frames tightly against the saw frames whereby the latter are firmly locked, substantially as described.

4. In a stave machine the combination with a table or bed and with a carriage tapering upwardly toward its rearward end and adapted to reciprocate upon the table, of a pair of circular saws located upon opposite sides of the table, laterally swing frames for carrying the saws, clamping frames for locking the saw frames, contact or adjusting plates interposed between the clamping frames and the saw frames and adjustable with reference to the former, whereby the alignment of the saws with reference to the carriage movement can be adjusted, and set screws  $r, r'$  for controlling the adjusting plates, substantially as described, and for the purpose set forth.

5. In a stave machine the combination with a table or carriage way, of a pair of circular saws located upon opposite sides of the table and in divergent planes, the lines of the table top and of the intersection of the planes of the saws diverging, substantially as described and for the purpose specified.

In testimony whereof I affix my signature in presence of two witnesses.

NELSON BURR.

Witnesses:

L. K. GILLSON,  
MAY H. L. WING.