

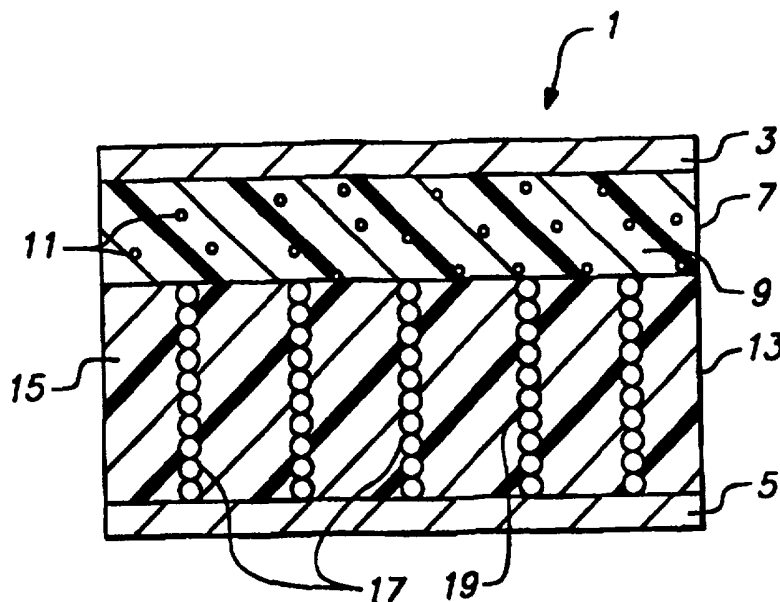

INTERNATIONAL APPLICATION PUBLISHED UNDER THE PATENT COOPERATION TREATY (PCT)

<p>(51) International Patent Classification⁶ : H01C 7/02</p>	<p>A1</p>	<p>(11) International Publication Number: WO 97/21230 (43) International Publication Date: 12 June 1997 (12.06.97)</p>
<p>(21) International Application Number: PCT/US96/19319 (22) International Filing Date: 5 December 1996 (05.12.96) (30) Priority Data: 08/568,716 7 December 1995 (07.12.95) US (71) Applicant: RAYCHEM CORPORATION [US/US]; 300 Constitution Drive, Mail Stop 120/6600, Menlo Park, CA 94025-1164 (US). (72) Inventors: SIMENDINGER, William, H., III; 3916 Yateswood Court, Raleigh, NC 27603 (US). BOYER, Charles, A.; Apartment H, 3330 Walnut Creek Parkway, Raleigh, NC 27606 (US). BUKOVNIK, Rudolf, R.; 100 Red Cedar Place, Chapel Hill, NC 27514 (US). (74) Agents: GERSTNER, Marguerite, E. et al.; Raychem Corporation, Intellectual Property Law Dept., 300 Constitution Drive, Mail Stop 120/6600, Menlo Park, CA 94025-1164 (US).</p>		<p>(81) Designated States: AL, AM, AT, AU, AZ, BB, BG, BR, BY, CA, CH, CN, CZ, DE, DK, EE, ES, FI, GB, GE, HU, IL, IS, JP, KE, KG, KR, KZ, LK, LR, LS, LT, LU, LV, MD, MG, MK, MN, MW, MX, NO, NZ, PL, PT, RO, RU, SD, SE, SG, SI, SK, TJ, TM, TR, TT, UA, UG, UZ, VN, Eurasian patent (AM, AZ, BY, KG, KZ, MD, RU, TJ, TM), European patent (AT, BE, CH, DE, DK, ES, FI, FR, GB, GR, IE, IT, LU, MC, NL, PT, SE).</p> <p>Published <i>With international search report. Before the expiration of the time limit for amending the claims and to be republished in the event of the receipt of amendments.</i></p>

(54) Title: ELECTRICAL DEVICE



(57) Abstract

An electrical device (1) in which a first resistive element (7) which is composed of a first electrically non-linear composition is in electrical contact, and preferably in physical and electrical contact, with a second resistive element (13) which is composed of a second composition which has a resistivity of less than 100 ohm-cm. The first composition has a resistivity of more than 10^9 ohm-cm and contains a first particulate filler (11). The second composition contains a second particulate filler (19) which (a) is magnetic and electrically conductive, and (b) is aligned in discrete regions (17) in the second polymeric component (15). The device also contains first and second electrodes (3, 5) which are positioned so that current can flow between the electrodes through the first and second resistive elements. Devices of the invention have relatively low breakdown voltages and can survive high energy fault conditions.

FOR THE PURPOSES OF INFORMATION ONLY

Codes used to identify States party to the PCT on the front pages of pamphlets publishing international applications under the PCT.

AM	Armenia	GB	United Kingdom	MW	Malawi
AT	Austria	GE	Georgia	MX	Mexico
AU	Australia	GN	Guinea	NE	Niger
BB	Barbados	GR	Greece	NL	Netherlands
BE	Belgium	HU	Hungary	NO	Norway
BF	Burkina Faso	IE	Ireland	NZ	New Zealand
BG	Bulgaria	IT	Italy	PL	Poland
BJ	Benin	JP	Japan	PT	Portugal
BR	Brazil	KE	Kenya	RO	Romania
BY	Belarus	KG	Kyrgystan	RU	Russian Federation
CA	Canada	KP	Democratic People's Republic of Korea	SD	Sudan
CF	Central African Republic	KR	Republic of Korea	SE	Sweden
CG	Congo	KZ	Kazakhstan	SG	Singapore
CH	Switzerland	LI	Liechtenstein	SI	Slovenia
CI	Côte d'Ivoire	LK	Sri Lanka	SK	Slovakia
CM	Cameroon	LR	Liberia	SN	Senegal
CN	China	LT	Lithuania	SZ	Swaziland
CS	Czechoslovakia	LU	Luxembourg	TD	Chad
CZ	Czech Republic	LV	Larvia	TG	Togo
DE	Germany	MC	Monaco	TJ	Tajikistan
DK	Denmark	MD	Republic of Moldova	TT	Trinidad and Tobago
EE	Estonia	MG	Madagascar	UA	Ukraine
ES	Spain	ML	Mali	UG	Uganda
FI	Finland	MN	Mongolia	US	United States of America
FR	France	MR	Mauritania	UZ	Uzbekistan
GA	Gabon			VN	Viet Nam

ELECTRICAL DEVICE

BACKGROUND OF THE INVENTION

5

Field of the Invention

This invention relates to electrical devices comprising electrically non-linear compositions.

10

Introduction to the Invention

Devices comprising electrically non-linear compositions are known for protecting electrical equipment and circuitry. The compositions used in such devices often exhibit non-linear electrical resistivity, decreasing in resistivity from an insulating state, i.e. more than 10^6 ohm-cm, to a conducting state when exposed to a voltage that exceeds a threshold value. This value is known as the breakdown voltage. Compositions exhibiting non-linear electrical behavior are disclosed in U.S. Patents Nos. 4,977,357 (Shrier), 5,294,374 (Martinez et al), and 5,557,250 (Debbaut et al), in International Publication No. WO95/33278 (Raychem Corporation), and in International Application No. PCT/US96/09113 (Raychem Corporation).

20

Electrical devices prepared from these conventional compositions have been described. See, for example, International Publication No. WO95/33278 which discloses an electrically non-linear resistive element suitable for repeated use as the secondary protection in a telecommunications gas tube apparatus. That resistive element comprises a composition in which a particulate filler such as aluminum is dispersed in a polymeric matrix. The composition has an initial resistivity ρ_i at 25°C of at least 10^9 ohm-cm and, even after exposure to a standard impulse breakdown test in which a high energy impulse is applied across the element five times, has a final resistivity ρ_f at 25°C of at least 10^9 ohm-cm. However, such devices, when exposed to a high energy fault condition, will short out and are thus not reusable. Furthermore, the scatter in the breakdown voltage on successive test events is relatively broad.

30

International Application No. PCT/US96/09113 discloses a device which is designed to protect electrical components as a primary protection device rather than as a secondary protection device. In this device, a resistive element is positioned between two

35

electrodes and is composed of a polymeric component in which a first magnetic, electrically conductive particulate filler and a second magnetic particulate filler with a resistivity of at least 1×10^4 ohm-cm are aligned in discrete regions extending from the first to the second electrode. In order to increase the electrical stability of the device, a
5 conductive intermediate layer, e.g. a conductive adhesive or a conductive polymer layer, is positioned between the resistive element and an electrode. This intermediate layer has a resistivity substantially lower than that of the resistive element. While such devices have improved stability over conventional devices, they require relatively high
breakdown voltages, exhibit relatively high scatter, and are not able to withstand the high
10 power conditions necessary for some applications.

SUMMARY OF THE INVENTION

In order to provide maximum protection, it is preferred that the breakdown voltage
15 of the device be relatively low, e.g. less than 500 volts, so that the device will operate under fault conditions in which the applied voltage is relatively low. It is also preferred that the breakdown voltage be relatively constant after multiple fault conditions. In order to effectively and repeatedly provide protection, it is preferred that the device have a
relatively stable insulation resistance, i.e. an insulation resistance of more than 1×10^9
20 ohms after exposure to a breakdown voltage is usually required. Furthermore, it is desirable that the device have the capability to withstand high energy fault conditions such as a lightning-type surge, i.e. a 10×1000 microsecond current waveform and a peak current of 60A. We have now found that a device which comprises at least two layers of different materials can exhibit each of these features. In a first aspect this invention
25 provides an electrical device which comprises

- (A) a first resistive element which is composed of a first electrically non-linear composition which (i) has a resistivity at 25°C of more than 10^8 ohm-cm and (ii) comprises
30
- (1) a first polymeric component, and
 - (2) a first particulate filler dispersed in the first polymeric component;
- (B) a second resistive element which (i) is in electrical contact, and preferably in physical and electrical contact, with the first element, and (ii) is
35

composed of a second composition which has a resistivity of less than 100 ohm-cm and which comprises

- 5
- (1) a second polymeric component, and
 - (2) a second particulate filler which (a) is magnetic and electrically conductive, and (b) is aligned in discrete regions in the second polymeric component; and
- 10 (C) first and second electrodes which are positioned so that current can flow between the electrodes through the first element and the second element.

BRIEF DESCRIPTION OF THE DRAWINGS

15 The invention is illustrated by the drawings in which Figure 1 is a schematic cross-sectional view of an electrical device according to the first aspect of the invention;

Figure 2 is a cross-sectional view of a test fixture used to test a device of the invention; and

20

Figures 3, 4, 5a to 5d, and 6 are graphs of breakdown voltage as a function of test cycle number for devices of the invention.

DETAILED DESCRIPTION OF THE INVENTION

25

The electrical device of the invention comprises at least two resistive elements which, in the preferred embodiment, are in physical and electrical contact with each other. In this specification, the term "electrical contact" means having electrical continuity and includes configurations in which there may not be direct physical contact. It is preferred that the two resistive elements be electrically connected in series, so that electrical current flows through the first resistive element and then the second resistive element. The first resistive element is composed of a first composition which exhibits electrically non-linear behavior. In this specification the term "non-linear" means that the composition is substantially electrically non-conductive, i.e. has a resistivity of more than 10^6 ohm-cm, and preferably more than 10^8 ohm-cm, when an applied voltage is less than the impulse breakdown voltage, but then becomes electrically conductive, i.e. has a resistivity of substantially less than 10^6 ohm-cm, when the applied voltage is equal to or greater than

30

35

the impulse breakdown voltage. For many applications, it is preferred that the first composition have a resistivity in the "non-conducting" state of more than 10^8 ohm-cm, particularly more than 10^9 ohm-cm, especially more than 10^{10} ohm-cm, and a resistivity in the "conducting" state of less than 10^3 ohm-cm.

5

The second resistive element is composed of a second composition which, when cured, is electrically conductive, i.e. has a resistivity of less than 10^5 ohm-cm, preferably less than 10^3 ohm-cm, particularly less than 100 ohm-cm, more particularly less than 10 ohm-cm, especially less than 1 ohm-cm, most especially less than 0.5 ohm-cm. The second composition may exhibit positive temperature coefficient (PTC) behavior, i.e. an increase in resistivity over a relatively narrow temperature range.

10

The first composition comprises a first polymeric component in which is dispersed a first particulate filler and an optional third particulate filler. The second composition comprises a second polymeric component which contains a second particulate filler and an optional fourth particulate filler. The first and second polymeric components may be the same or different and may be any appropriate polymer, e.g. a thermoplastic material such as a polyolefin, a fluoropolymer, a polyamide, a polycarbonate, or a polyester; a thermosetting material such as an epoxy; an elastomer (including silicone elastomers, acrylates, polyurethanes, polyesters, and liquid ethylene/propylene/diene monomers); a grease; or a gel. It is preferred that both the first and the second polymeric components be a curable polymer, i.e. one that undergoes a physical and/or chemical change on exposure to an appropriate curing condition, e.g. heat, light, radiation (by means of an electron beam or gamma irradiation such as a Co^{60} source), microwave, a chemical component, or a temperature change.

15

20

25

For many applications it is preferred that the first and/or the second polymeric component comprise a polymeric gel, i.e. a substantially dilute crosslinked solution which exhibits no flow when in the steady-state. The crosslinks, which provide a continuous network structure, may be the result of physical or chemical bonds, crystallites or other junctions, and must remain intact under the use conditions of the gel. Most gels comprise a fluid-extended polymer in which a fluid, e.g. an oil, fills the interstices of the network. Suitable gels include those comprising silicone, e.g. a polyorganosiloxane system, polyurethane, polyurea, styrene-butadiene copolymers, styrene-isoprene copolymers, styrene-(ethylene/propylene)-styrene (SEPS) block copolymers (available under the tradename Septon™ by Kuraray), styrene-(ethylene-propylene/ethylene-butylene)-styrene block copolymers (available under the tradename Septon™ by Kuraray), and/or styrene-

30

35

(ethylene/butylene)-styrene (SEBS) block copolymers (available under the tradename Kraton™ by Shell Oil Co.). Suitable extender fluids include mineral oil, vegetable oil, paraffinic oil, silicone oil, plasticizer such as trimellitate, or a mixture of these, generally in an amount of 30 to 90% by volume of the total weight of the gel without filler. The gel
5 may be a thermosetting gel, e.g. silicone gel, in which the crosslinks are formed through the use of multifunctional crosslinking agents, or a thermoplastic gel, in which microphase separation of domains serves as junction points. Disclosures of gels which may be suitable as the first and/or the second polymeric component in the composition are found in U.S. Patent Nos. 4,600,261 (Debbaut), 4,690,831 (Uken et al), 4,716,183
10 (Gamarra et al), 4,777,063 (Dubrow et al), 4,864,725 (Debbaut et al), 4,865,905 (Uken et al), 5,079,300 (Dubrow et al), 5,104,930 (Rinde et al), and 5,149,736 (Gamarra); and in International Patent Publication Nos. WO86/01634 (Toy et al), WO88/00603 (Francis et al), WO90/05166 (Sutherland), WO91/05014 (Sutherland), and WO93/23472 (Hammond et al).

15

The first polymeric component generally comprises 30 to 99%, preferably 30 to 95%, particularly 35 to 90%, especially 40 to 85% by volume of the total first composition. The second polymeric component generally comprises 50 to 99.99%, preferably 55 to 99.9%, particularly 60 to 99.9%, especially 65 to 99.9%, e.g. 70 to 99%,
20 by volume of the total second composition.

Dispersed in the first polymeric component is a first particulate filler which may be electrically conductive, nonconductive, or a mixture of two or more types of fillers as long as the resulting composition has the appropriate electrical non-linearity. In this
25 specification the term "electrically conductive" is used to mean a filler which is conductive or semiconductive and which has a resistivity of less than 10^2 ohm-cm and is preferably much lower, i.e. less than 1 ohm-cm, particularly less than 10^{-1} ohm-cm, especially less than 10^{-3} ohm-cm. It is generally preferred that the filler be conductive or semiconductive. Conductive fillers generally have a resistivity of at most 10^{-3} ohm-cm;
30 semiconductive fillers generally have a resistivity of at most 10^2 ohm-cm, although their resistivity is a function of any dopant material, as well as temperature and other factors and can be substantially higher than 10^2 ohm-cm. Suitable fillers include metal powders, e.g. aluminum, nickel, silver, silver-coated nickel, platinum, copper, tantalum, tungsten, gold, and cobalt; metal oxide powders, e.g. iron oxide, doped iron oxide, doped titanium
35 dioxide, and doped zinc oxide; metal carbide powders, e.g. silicon carbide, titanium carbide, and tantalum carbide; metal nitride powders; metal boride powders; carbon black or graphite; and alloys, e.g. bronze and brass. It is also possible to use glass or ceramic

particles, e.g. spheres, coated with any conductive material. Particularly preferred as fillers are aluminum, iron oxide (Fe_3O_4), iron oxide doped with titanium dioxide, silicon carbide, and silver-coated nickel. If the first polymeric component is a gel, it is important that the selected filler not interfere with the crosslinking of the gel, i.e. not "poison" it.

- 5 The first filler is generally present in an amount of 1 to 70%, preferably 5 to 70%, particularly 10 to 65%, especially 15 to 60% by volume of the total first composition.

The volume loading, shape, and size of the filler affect the non-linear electrical properties of the first composition, in part because of the spacing between the particles.

- 10 Any shape particle may be used, e.g. spherical, flake, fiber, or rod, although particles having a substantially spherical shape are preferred. Useful first compositions can be prepared with particles having an average size of 0.010 to 100 microns, preferably 0.1 to 75 microns, particularly 0.5 to 50 microns, especially 1 to 20 microns. A mixture of different size, shape, and/or type particles may be used. The particles may be magnetic or
15 nonmagnetic. Examples of compositions suitable for use in the first composition are found in International Publication No. WO95/33278.

- The second composition comprises a second particulate filler which is present at 0.01 to 50%, preferably 0.1 to 45%, particularly 0.1 to 40%, especially 0.1 to 35%, e.g. 1
20 to 30%, by volume of the total second composition. The second filler is both electrically conductive and magnetic. The term "magnetic" is used in this specification to mean ferromagnetic, ferrimagnetic, and paramagnetic materials. The filler may be completely magnetic, e.g. a nickel sphere; it may comprise a non-magnetic core with a magnetic coating, e.g. a nickel-coated ceramic particle; or it may comprise a magnetic core with a
25 non-magnetic coating, e.g. a silver-coated nickel particle. Suitable second fillers include nickel, iron, cobalt, ferric oxide, silver-coated nickel, silver-coated ferric oxide, or alloys of these materials. Any shape particle may be used, although approximately spherical particles are preferred. In general, the primary particle size of the second filler is less than 300 microns, preferably less than 200 microns, particularly less than 150 microns,
30 especially less than 100 microns, and is preferably in the range of 0.05 to 40 microns, particularly 1 to 10 microns. Because processing techniques, e.g. coating the primary particle, may result in agglomeration, it is possible that the second filler, as mixed into the second polymeric component, may have an agglomerate size of as much as 300 microns. For some applications, a mixture of different particle sizes and/or shapes and/or materials
35 may be desirable.

The second particulate filler is aligned in discrete regions or domains of the second polymeric component, e.g. as a column that extends through the second polymeric component from one side to the other, in particular from one side of the second resistive element (generally in contact with an electrode) to the first resistive element. Such domains can be formed in the presence of a magnetic field that causes the magnetic first and second filler particles to align. When such alignment occurs during curing of the polymeric component, the alignment is maintained in the cured polymeric component. The resulting alignment provides anisotropic conductivity. Any type of magnetic field that is capable of supplying a field strength sufficient to align the particles may be used. A conventional magnet of any type, e.g. ceramic or rare earth, may be used, although for ease in manufacture, it may be preferred to use an electromagnet with suitably formed coils to generate the desired magnetic field. It is often preferred that the uncured polymeric component be positioned between two magnets during the curing process, although for some applications, e.g. a particular device geometry, or the need to cure by means of ultraviolet light, it can be sufficient that there be only one magnet that is positioned on one side of the polymeric component. The polymeric component is generally separated from direct contact with the magnets by means of an electrically insulating spacing layer, e.g. a polycarbonate, polytetrafluoroethylene, or silicone sheet, or by means of first and second electrodes. It is important that the amount of second filler present produces a resistive element which has conductivity only through the thickness of the resistive element, not between adjacent columns, thus providing anisotropic conductivity.

In order to improve the electrical performance of devices of the invention, it is preferred that the first composition and the second composition comprise at least one additional particulate filler, i.e. a third particulate filler for the first composition and a fourth particulate filler for the second composition. This additional particulate filler may be the same for both the first and second compositions, or it may be different. In addition, the additional particulate filler may comprise a mixture of two or more different materials, which may be the same or different, and in the same concentration or different concentrations, for the first and second compositions. The third particulate filler is present in an amount of 0 to 60%, preferably 5 to 50%, particularly 10 to 40% by total volume of the first composition. The fourth particulate filler is present in an amount of 0 to 60%, preferably 5 to 50%, particularly 10 to 40% by total volume of the second composition. Particularly preferred for use as the third or fourth particulate fillers are arc suppressing agents or flame retardants, and oxidizing agents. Compositions with particularly good performance under high current conditions, e.g. 250A, have been

prepared when the third and/or the fourth particulate filler comprises a mixture of (i) an arc suppressing agent or flame retardant, and (ii) an oxidizing agent. It is preferred that the oxidizing agent be present in an amount 0.1 to 1.0 times that of the arc suppressing agent or flame retardant. The oxidizing agent is generally present at 0 to 20%, preferably 5 to 15% by total volume of the first composition, and/or at 0 to 20%, preferably 5 to 15% by total volume of the second composition. Particularly good results are achieved when the oxidizing agent is coated onto the arc suppressing agent or flame retardant prior to mixing. Suitable arc suppressing agents and flame retardants include zinc borate, magnesium hydroxide, alumina trihydrate, aluminum phosphate, barium hydrogen phosphate, calcium phosphate (tribasic or dibasic), copper pyrophosphate, iron phosphate, lithium phosphate, magnesium phosphate, nickel phosphate, zinc phosphate, calcium oxalate, iron (II) oxalate, manganese oxalate, strontium oxalate, and aluminum trifluoride trihydrate. It is important that any decomposition products of the arc suppressing agent be electrically nonconductive. Suitable oxidizing agents include potassium permanganate, ammonium persulfate, magnesium perchlorate, manganese dioxide, bismuth subnitrate, magnesium dioxide, lead dioxide (also called lead peroxide), and barium dioxide. While we do not wish to be bound by any theory, it is believed that the presence of the arc suppressing agent or flame retardant, and the oxidizing agent controls the plasma chemistry of the plasma generated during an electrical discharge, and provides discharge products that are nonconductive.

For some applications, it is preferred that the third and/or fourth particulate fillers comprise a surge initiator. Surge initiators have a low decomposition temperature, e.g. 150 to 200°C, and act to decrease the breakdown voltage of the composition and provide more repeatable breakdown voltage values. Suitable surge initiators include oxalates, carbonates, or phosphates. The surge initiator may also act as an arc suppressant for some compositions. If present, the surge initiator generally comprises 5 to 30%, preferably 5 to 25% by total volume of the composition.

Both the first composition and the second composition may comprise additional components including antioxidants, radiation crosslinking agents (often referred to as prorads or crosslinking enhancers), stabilizers, dispersing agents, coupling agents, acid scavengers, or other components. These components generally comprise at most 10% by volume of the total composition in which they are present.

The first and second compositions may be prepared by any suitable means, e.g. melt-blending, solvent-blending, or intensive mixing. Because it is preferred that the first

and second polymeric components have a relatively low viscosity, particularly prior to curing, the fillers can be mixed into the polymeric component by hand or by the use of a mechanical stirrer. Mixing is conducted until a uniform dispersion of the filler particles is achieved. The composition may be shaped by conventional methods including extrusion, calendaring, casting, and compression molding. If the polymeric component is a gel, the gel may be mixed with the fillers by stirring and the composition may be poured or cast onto a substrate or into a mold to be cured.

In order to accommodate the necessary loading of the particulate fillers, and to allow alignment of the fillers in the polymeric component, it is preferred that the first and second polymeric components, prior to any curing and without any filler, have a viscosity at room temperature of at most 200,000 cps, preferably at most 100,000 cps, particularly at most 10,000 cps, especially at most 5,000 cps, more especially at most 1,000 cps. This viscosity is generally measured by means of a Brookfield viscometer at the cure temperature, T_c , if the polymeric component is curable, or at the mixing temperature at which the particulate fillers are dispersed and subsequently aligned if the polymeric component is not curable.

The electrical device of the invention comprises at least one first resistive element which is preferably in electrical and physical contact with at least one second resistive element. It is preferred that the first and second elements be in direct physical and electrical contact with one another, but it is possible that only some part of the first and second elements is in direct physical contact, or that there is an intermediate layer, e.g. a metal sheet, between the two elements. While a single first resistive element and a single second resistive element can be used, it is also possible that two first resistive elements may be positioned on opposite sides of a second resistive element, or two second resistive elements may be positioned on opposite sides of a first resistive element. The direction of conductivity of the second resistive element is perpendicular to the plane of the first resistive element. Depending on the method of preparing the resistive elements, they may be of any thickness or geometry, although both the first and the second resistive elements are of generally laminar configuration. In a preferred configuration, the first resistive element has a thickness of 0.25 to 1.0 mm, while the second resistive element has a thickness of 1.0 to 2.0 mm. The first and second resistive elements may be attached by any suitable method, e.g. a physical attachment method such as a clamp, or an attachment resulting from physical or chemical bonds. In some cases, if the first and second compositions are curable, the first and second resistive elements may be cured in contact with one another, as long as it is possible to properly align the second particulate filler.

The electrical device comprises first and second electrodes which are positioned so that, when the device is connected to a source of electrical power, current can flow between the electrodes through the first and second resistive elements. Generally the first electrode is attached to the first resistive element, and the second electrode to the second resistive element, but if the device comprises a center first resistive element sandwiched between two second resistive elements, the first electrode may be positioned in contact with one second resistive element and the second electrode may be positioned in contact with the other second resistive element. Similarly, if the device comprises a center second resistive element between two first resistive elements, the first and second electrodes may be positioned in contact with the two first resistive elements. The electrodes and the resistive elements are configured so that the first and second resistive elements are electrically in series. The type of electrode is dependent on the shape of the first and second elements, but is preferably laminar and in the form of a metal foil, metal mesh, or metallic ink layer. The first electrode has a first resistivity and the second electrode has a second resistivity, both of which are generally less than 1×10^{-2} ohm-cm, preferably less than 1×10^{-3} ohm-cm, particularly less than 1×10^{-4} ohm-cm. Particularly suitable metal foil electrodes comprise microrough surfaces, e.g. electrodeposited layers of nickel or copper, and are disclosed in U.S. Patents Nos. 4,689,475 (Matthiesen) and 4,800,253 (Kleiner et al), and in International Publication No. WO95/34081 (Raychem Corporation).

Depending on the type of the polymeric components and the electrodes, it may be desirable to cure the first and second compositions directly in contact with the electrodes. Alternatively, it is possible to cure the compositions partially or completely before attaching the electrodes to the cured compositions. The latter technique is especially appropriate for use with mesh or other foraminous electrode materials. In order to control the thickness of the first and second resistive elements, the uncured composition may be poured or otherwise positioned within a mold of specified thickness, and then cured. For some applications, improved electrical stability for the device may be achieved if at least one and preferably both of the electrodes is both electrically conductive and has at least some portion which is magnetic. Electrodes of this type include nickel, nickel-coated copper, and stainless steel. It is preferred that the entire surface of the electrode comprise the magnetic material. Similar electrodes and techniques may be used to prepare electrical devices as described in International Application No. PCT/US96/09103 (Raychem Corporation).

The first and second polymeric components may be cured by any suitable means, including heat, light, microwave, electron beam, or gamma irradiation, and are often cured by using a combination of time and temperature suitable to substantially cure the polymeric components. The curing temperature T_c may be at any temperature that allows

5 substantial curing of the polymeric component, i.e. that cures the polymeric component to at least 70%, preferably at least 80%, particularly at least 90% of complete cure. When the curable polymeric component is a thermosetting resin which has a glass transition temperature T_g , it is preferred that the curing be conducted at a curing temperature T_c which is greater than T_g . A catalyst, e.g. a platinum catalyst, may be added to initiate the

10 cure and control the rate and/or uniformity of the cure. When the polymeric component is a gel, it is preferred that, when cured without any filler, the gel be relatively hard, i.e. have a Voland hardness of at least 100 grams, particularly at least 200 grams, especially at least 300 grams, e.g. 400 to 600 grams, in order to minimize disruption of the aligned particles when exposed to a high energy condition. In addition, it is preferred that the cured gel

15 have stress relaxation of less than 25%, particularly less than 20%, especially less than 15%. The Voland hardness and stress relaxation are measured using a Voland-Stevens Texture Analyzer Model LFRA having a 1000 gram load cell, a 5 gram trigger, and a 0.25 inch (6.35 mm) ball probe, as described in U.S. Patent No. 5,079,300 (Dubrow et al). To measure the hardness of a gel, a 20 ml glass scintillating vial containing 10 grams of gel

20 is placed in the analyzer and the stainless steel ball probe is forced into the gel at a speed of 0.20 mm/second to a penetration distance of 4.0 mm. The Voland hardness value is the force in grams required to force the ball probe at that speed to penetrate or deform the surface of the gel the specified 4.0 mm. The Voland hardness of a particular gel may be directly correlated to the ASTM D217 cone penetration hardness using the procedure

25 described in U.S. Patent No. 4,852,646 (Dittmer et al).

The device of the invention is nonconductive, i.e. has an insulation resistance at 25°C of more than 10^6 ohms, preferably more than 10^8 ohms, particularly more than 10^9 ohms, especially more than 10^{10} ohms. The resistance of the second resistive element at

30 25°C, if measured on its own, not in contact with the first resistive element, is at most 1000 ohms, preferably at most 100 ohms, particularly at most 10 ohms, especially at most 1 ohm.

Electrical devices of the invention, when tested according to the Standard Impulse

35 Breakdown Voltage Test, described below, preferably exhibit low breakdown voltage and maintain a high insulation resistance. Thus the breakdown voltage when tested at either 60A or 250A is at most 1000 volts, preferably at most 800 volts, particularly at most 700

volts, especially at most 600 volts, more especially at most 500 volts, e.g. 200 to 500 volts, and the final insulation resistance is at least 10^8 ohms, as described above. It is preferred that the breakdown voltage be relatively stable over multiple cycles of the test, i.e. for any given cycle, the breakdown voltage varies from the average breakdown
5 voltage for fifty cycles by $\pm 70\%$, preferably by $\pm 50\%$. When the composition of the invention is formed into a standard device as described below and exposed to a standard impulse breakdown test, the device has an initial breakdown voltage V_{Si} and a final
breakdown voltage V_{Sf} which is from $0.70V_{Si}$ to $1.30V_{Si}$, preferably from $0.80V_{Si}$ to $1.20V_{Si}$, particularly from $0.85V_{Si}$ to $1.15V_{Si}$, especially from $0.90V_{Si}$ to $1.10V_{Si}$.

10

The first resistive element acts as a "switch" due to its non-linear nature, and controls the breakdown voltage of the device. However, if exposed to a very high energy pulse, e.g. a 10×1000 microsecond current waveform and a peak current of 300A, a small region in the first resistive element will short out if not in contact with the second
15 resistive element. The second resistive element acts as a "point-plane" electrode. Each of the domains, generally in the form of columns, behaves as a microfuse which can be destroyed by the breakdown event. As a result, even if an affected portion of the first resistive element shorts out, a corresponding domain in the second resistive element will be destroyed, and will disconnect the shorted section of the first resistive element from
20 the circuit. The device thus returns to a nonconductive state after the breakdown event. In addition, the electric field is concentrated at the tip of each domain or column, thus increasing the repeatability of the breakdown voltage on successive electrical events.

The invention is illustrated by the drawing in which Figure 1 shows in cross-
25 section electrical device 1. First electrode 3 is in contact with first resistive element 7, while second electrode 5 is in contact with second resistive element 13. First resistive element 7 is made of first polymeric component 9 which acts as a matrix in which is dispersed first particulate filler 11. Second resistive element 13 is made of second polymeric component 15 through which is dispersed in discrete domains aligned chains
30 17. Each chain 17 contains particles of second particulate filler 19.

The invention is illustrated by the following examples, each of which was tested using the Standard Impulse Breakdown Test.

Standard Device

Both the first composition and the second composition were prepared by mixing the designated components with a tongue depressor or mechanical stirrer to wet and
5 disperse the particulate filler. Each composition was degassed in a vacuum oven for one minute. The second composition was poured onto a PTFE-coated release sheet, and covered with a second PTFE-coated release sheet separated from the first sheet by spacers having a thickness of about 1 mm. The outer surfaces of the release sheets were supported with rigid metal sheets and magnets with dimensions of 51 x 51 x 25 mm (2 x 2
10 x 1 inch) and having a pull force of 10 pounds (available from McMaster-Carr) were positioned over the metal sheets, sandwiching the composition. The second composition was then cured at 100°C for 15 minutes. The top magnet, the top metal sheet, and the top release sheet were removed, additional spacers were added to give a thickness of 1.5 mm, and the first composition was poured onto the surface of the cured second composition.
15 The top release sheet and the top metal sheet were replaced and a weight (which may be the top magnet) was placed on top of the top metal sheet. The arrangement was then cured at 100°C for an additional 15 minutes to give a laminate of the first and second compositions. A disc 20 (as shown in Figure 2) with a diameter of 15.9 mm and a thickness of 1.5 mm was cut from the cured laminate. The disc 20 consisted of a second
20 resistive element 21 with a thickness of 1.0 mm from the cured second composition and a first resistive element 22 with a thickness of 0.5 mm from the first composition. Molybdenum electrodes 23, 25 having a diameter of 15.9 mm and a thickness of 0.25 mm (0.010 inch) were attached to the top and bottom surfaces of disc 20 to form a standard device 27.

25

Standard Impulse Breakdown Test

A standard device 27 was inserted into the test fixture 29 shown in Figure 2. Two copper cylinders 31,33, approximately 19 mm (0.75 inch) in diameter, were mounted in a
30 polycarbonate holder 35 such that the end faces 37,39 were parallel. One end 37 was fixed and immobile; the other end 39 was free to travel while still maintaining the parallel end-face geometry. Movement of cylinder 33 was controlled by barrel micrometer 41 mounted through mounting ring 43. Device 27 was mounted between cylinders 31,33, and micrometer 41 was adjusted until contact with zero compressive pressure was made
35 to both sides of device 27. Pressure was then applied to device 27 by further moving cylinder 33 (via micrometer 41) to compress the sample 10% (generally 0.1 to 0.3 mm). Electrical leads 45,47 were connected from copper cylinders 31,33 to the testing

equipment (not shown). Prior to testing, the insulation resistance R_i for the device was measured at 25°C with a biasing voltage of 50 volts using a Genrad 1864 Megaohm meter; the initial resistivity ρ_i was calculated. Electrical connection was then made to a Keytek ECAT Series 100 Surge Generator using an E514A 10x1000 waveform generator.

5 For each cycle a high energy impulse with a 10 x 1000 μ s current waveform (i.e. a rise time to maximum current of 10 μ s and a half-height at 1000 μ s) and a peak current of 60A was applied. The peak voltage measured across the device at breakdown, i.e. the voltage at which current begins to flow through the gel, was recorded as the impulse breakdown voltage. The final insulation resistance R_f after fifty or one hundred cycles for

10 the standard test was measured and the final resistivity ρ_f was calculated.

Examples 1 to 15

The first and second resistive elements for Examples 1 to 15 were prepared from

15 compositions using the formulations shown in Table I. In each case the silicone gel was formulated using 49.420% 1000 cs divinyl-terminated polydimethylsiloxane (available from United Chemical Technology (UCT)), 49.956% 50 cs silicone oil (polydimethylsiloxane fluid from UCT), 0.580% tetrakis(dimethyl siloxy silane) (UCT), 0.04% catalyst, and 0.004% inhibitor, all amounts by weight of the composition. The

20 stoichiometry was adjusted for peak hardness, i.e. 600 grams using a Volland texture analyzer with a 7 mm stainless steel probe. The aluminum was a powder with an average particle size of 15 to 20 microns (-200 mesh) and a substantially spherical shape, available from Aldrich Chemicals. The nickel, available from Alfa Aesar, had a mesh size of -300 mesh and an average particle size of 3 to 10 microns. The arc suppressing

25 agents, i.e. magnesium phosphate ($Mg_3(PO_4)_2 \cdot 8H_2O$), zinc phosphate ($Zn_3(PO_4)_2 \cdot 2H_2O$), calcium phosphate ($CaHPO_4 \cdot 2H_2O$), iron oxalate ($FeC_2O_4 \cdot 2H_2O$), and zinc borate ($3ZnO \cdot 2B_2O_3$), the oxidizing agents, i.e. bismuth subnitrate ($4BiNO_3(OH)_2 \cdot BiO(OH)$) and lead peroxide (PbO_2), and the surge initiators, i.e. calcium carbonate ($CaCO_3$, decomposition temperature 898°C), manganese oxalate ($MnC_2O_4 \cdot 2H_2O$, decomposition

30 temperature 100°C), and iron oxalate (which also acts as an arc suppressing agent, decomposition temperature 190°C), were available from Alfa Aesar. Standard devices were prepared as above and tested using the Standard Impulse Breakdown Test for either 50 or 100 cycles, as indicated. (Testing for Example 11 was done at 100A rather than 60A.) In each case, except for comparative Examples 5 and 7, the devices had R_i greater

35 than 10^9 ohms. For Examples 5 and 7 the value of R_i was greater than 10^8 ohms. The

average breakdown voltage over the total number of test cycles and the standard deviation (i.e. a measure of the reproducibility of the breakdown voltage) are shown in Table I.

5 Examples 1 to 4, which contained an arc suppressing agent, showed good low breakdown voltage (i.e. less than 1000 volts, and, for Examples 2 to 4, less than 400 volts), and good reproducibility. Each had an R_f value of greater than 10^8 ohms. The test results for Example 2 are shown in Figure 3.

10 Examples 5 to 11 show the effects of the presence of both an arc suppressing agent and an oxidizing agent. Examples 5 and 7, which contained bismuth subnitrate in both the first and second resistive elements had an R_f value of 1×10^7 . When bismuth subnitrate, which becomes conductive when exposed to moisture, was used in the second resistive element only (Example 11), the device had an R_f value of greater than 10^8 ohms, and excellent reproducibility. Examples 12 to 15 show the effects of the presence of a surge initiator. Examples 14 and 15, which contained a surge initiator which had a low decomposition temperature, had low breakdown voltages and good reproducibility. Each 15 of Examples 12 to 15 had an R_f value of greater than 10^8 ohms. The test results for Examples 4, 9, 10, and 11 are shown in Figure 4. The test results for Examples 12 to 15 are shown in Figures 5a to 5d, respectively. In each of Figures 5a to 5d results are shown 20 for three different samples of each type of device. The values reported in Table I are averages of the three samples for each example.

Monolayer devices which contained only a first resistive element made from a composition containing aluminum powder dispersed in a silicone, shown, for example in 25 International Publication No. WO95/33278, the disclosure of which is incorporated herein by reference, had a breakdown voltage of more than 1000 volts when tested using a 10×1000 microsecond waveform and a current of at most 1A. They did not survive fifty cycles when tested at 60A.

30 Example 16

Following the procedure of Examples 1 to 15, a first composition was prepared containing 30% aluminum (-200 mesh), 10% zinc borate, 10% potassium permanganate, and 50% silicone gel (as in Example 1), and a second composition was prepared 35 containing 11.25% nickel with a mesh size of -100 to +200 (available from Alfa Aesar, with an average particle size of about 100 microns), 3.75% nickel with a mesh size of -300, 20% zinc borate, 10% potassium permanganate, and 55% silicone gel (as in Example

1), all percentages by volume of each total composition. A Standard Device was prepared and tested 50 cycles at 60A with a 10 x 1000 microsecond waveform. The average breakdown voltage was 318 volts, with a standard deviation of 27. Both R_i and R_f were 1×10^{11} ohms. The test results are shown in Figure 6.

5

Example 17

A device was prepared as in Example 16 and tested 50 cycles at 220A with a 10 x 1000 microsecond waveform. The average breakdown voltage was 365 volts, with a standard deviation of 32. Both R_i and R_f were 1×10^{11} ohms. The test results are shown in Figure 6.

10

TABLE I
(Loadings in Volume %)

Example	1	2	3	4	5*	6	7*	8	9	10	11	12	13	14	15
<u>First Element</u>															
Aluminum	30	30	30	30	30	30	30	30	30	30	30	30	30	30	30
Magnesium phosphate	20														
Zinc phosphate		20			10	10									
Calcium phosphate			20				10	10		10	10			5	
Iron oxalate				20											
Bismuth subnitrate					10		10		10						
Lead peroxide						10		10		10	10		15	10	10
Zinc borate													5		
Calcium carbonate															5
Manganese oxalate															
Silicone Gel	50	50	50	50	50	50	50	50	50	50	50	55	55	55	55

TABLE I, continued (Loadings in Volume %)

Example	1	2	3	4	5*	6	7*	8	9	10	11	12	13	14	15
<u>Second Element</u>															
Nickel	15	15	15	15	15	15	15	15	15	15	15	15	15	15	15
Magnesium phosphate	25														
Zinc phosphate		25			20	20									
Calcium phosphate			25				20	20							
Iron oxalate				25					20	20	20				
Bismuth subnitrate					10		10	10	10		10				
Lead peroxide						10		10		10					
Zinc borate												30	30	30	30
Manganese oxalate															
Silicone Gel	60	60	60	60	55	55	55	55	55	55	55	55	55	55	55
<u>Breakdown voltage</u>															
Average (volts)	882	354	327	342	384	324	402	400	498	292	413	477	565	365	501
Standard deviation	156	29	26	16	45	54	50	53	77	19	17	58	69	27	30
Test current (A)	60	60	60	60	60	60	60	60	60	60	100	60	60	60	60
Test cycles	50	50	50	50	50	100	50	100	100	100	100	50	50	50	50

*Examples 5 and 7 are comparative examples.

What is claimed is:

1. An electrical device which comprises
 - (A) a first resistive element which is composed of a first electrically non-linear composition which (i) has a resistivity at 25°C of more than 10^9 ohm-cm and (ii) comprises
 - (1) a first polymeric component, and
 - (2) a first particulate filler dispersed in the first polymeric component;
 - (B) a second resistive element which (i) is in electrical contact with the first element, and (ii) is composed of a second composition which has a resistivity of less than 100 ohm-cm and which comprises
 - (1) a second polymeric component, and
 - (2) a second particulate filler which (a) is magnetic and electrically conductive, and (b) is aligned in discrete regions in the second polymeric component; and
 - (C) first and second electrodes which are positioned so that current can flow between the electrodes through the first element and the second element.
2. A device according to claim 1 wherein the second resistive element is in physical contact with the first resistive element.
3. A device according to claim 1 wherein at least one of the first component and the second component comprises a curable polymer, preferably a curable polymer which has a viscosity of less than 200,000 cps when uncured.
4. A device according to claim 3 wherein the curable polymer comprises a gel, preferably a thermosetting gel or a thermoplastic gel.

5. A device according to claim 3 wherein the curable polymer comprises a thermosetting resin, preferably a silicone elastomer, an acrylate, an epoxy, or a polyurethane.
6. A device according to any one of the preceding claims wherein the first filler comprises a conductive filler or a semiconductive filler, and is selected from the group consisting of metal powders, metal oxide powders, metal carbide powders, metal nitride powders, and metal boride powders, preferably a filler which comprises aluminum, nickel, silver, silver-coated nickel, platinum, copper, tantalum, tungsten, iron oxide, doped iron oxide, doped zinc oxide, silicon carbide, titanium carbide, tantalum carbide, glass spheres coated with a conductive material, or ceramic spheres coated with a conductive material.
7. A device according to any one of the preceding claims wherein the first filler comprises 1 to 70% by volume of the first composition, and the second filler comprises 0.01 to 50% by volume of the second composition.
8. A device according to any one of the preceding claims wherein the second filler comprises nickel, iron, cobalt, ferric oxide, silver-coated nickel, silver-coated ferric oxide, or alloys of these materials.
9. A device according to any one of the preceding claims which comprises (i) two first resistive elements, positioned on opposite sides of the second resistive element, or (ii) two second resistive elements, positioned on opposite sides of the first resistive element.
10. A device according to any one of the preceding claims wherein
 - (A) the first resistive element further comprises a third particulate filler dispersed in the first polymeric component which is an arc suppressant, an oxidizing agent, or a surge initiator; and (i) the first polymeric component is a gel, and (ii) the first particulate filler is a conductive filler or a semiconductive filler, preferably aluminum; and
 - (B) the second resistive element (i) is in physical and electrical contact with the first element, (ii) has a resistance at 25°C of at most 100 ohms, and (iii) further comprises a fourth particulate filler dispersed in the second

polymeric component which is an arc suppressant, an oxidizing agent, or a surge initiator; and (a) the second polymeric component is a gel, and (b) the second particulate filler preferably comprises nickel;

said device having a breakdown voltage when measured at 60A in a Standard Impulse Breakdown Test of less than 1000 volts.

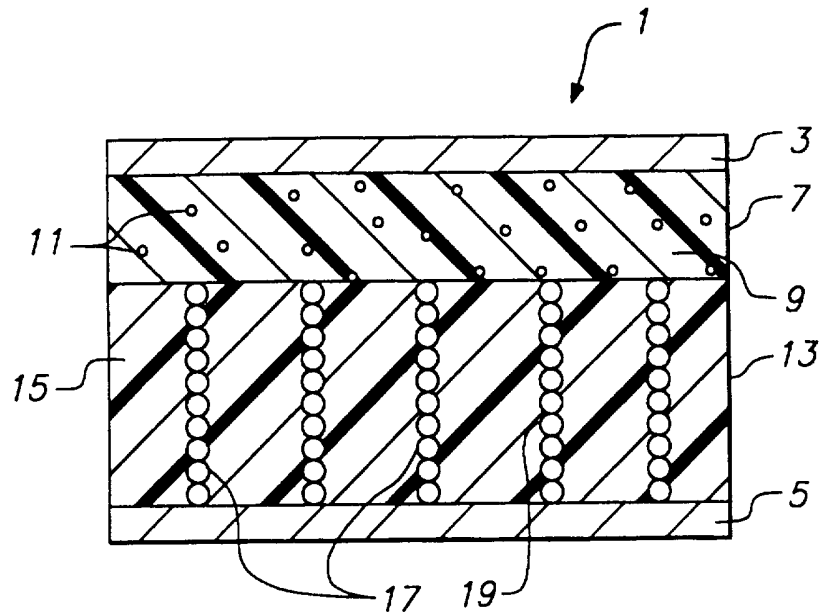

FIG. 1

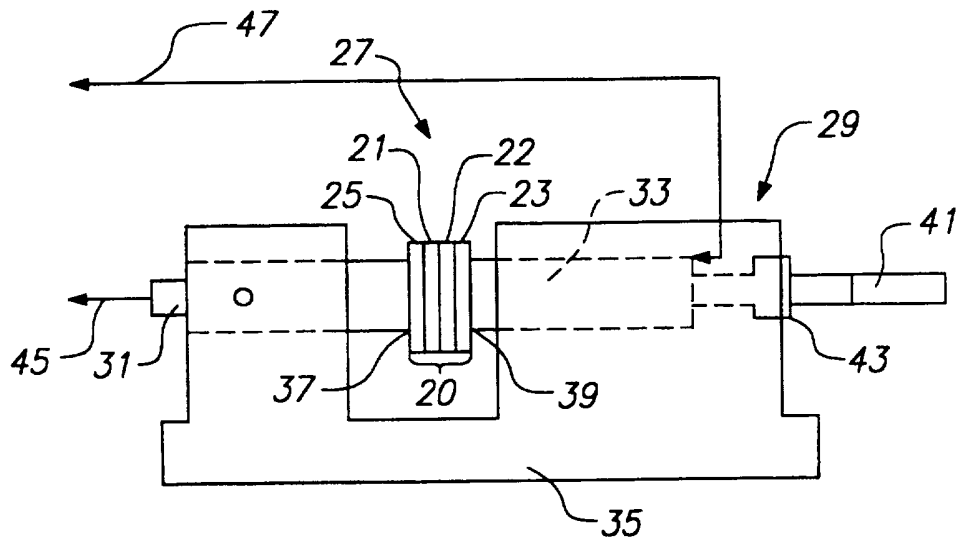

FIG. 2

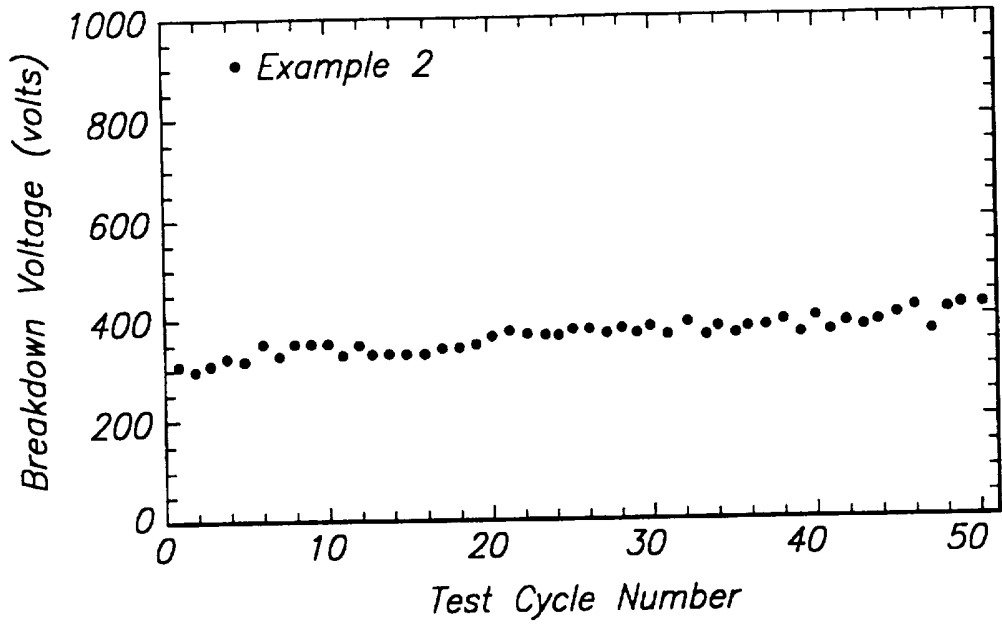

FIG. 3

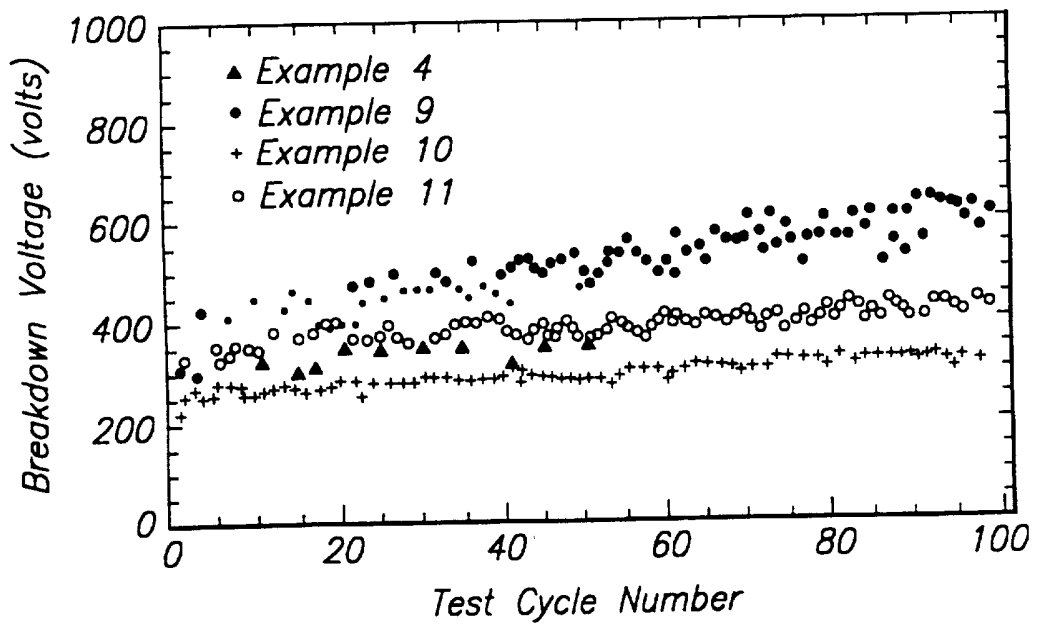

FIG. 4

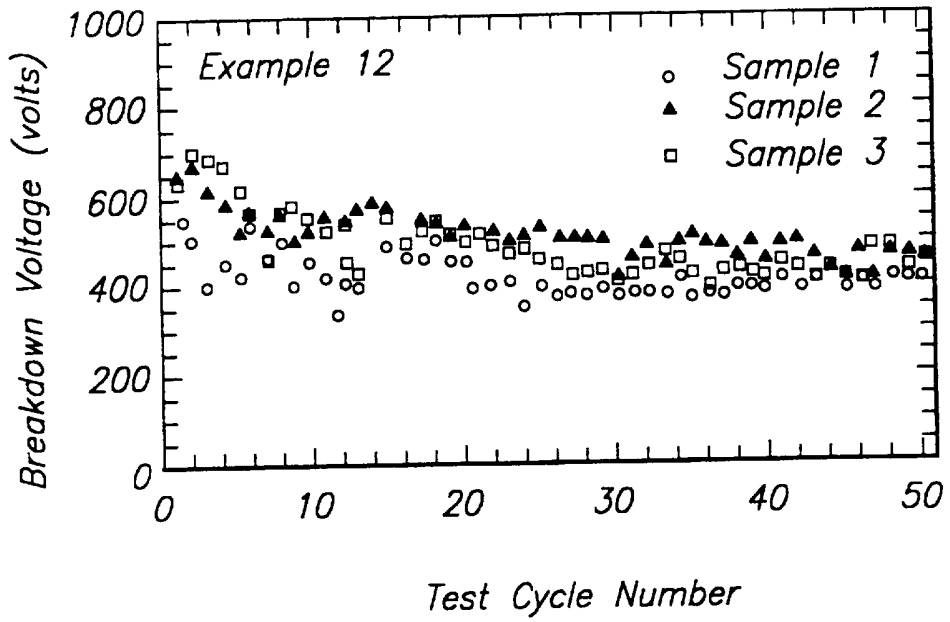

FIG. 5a

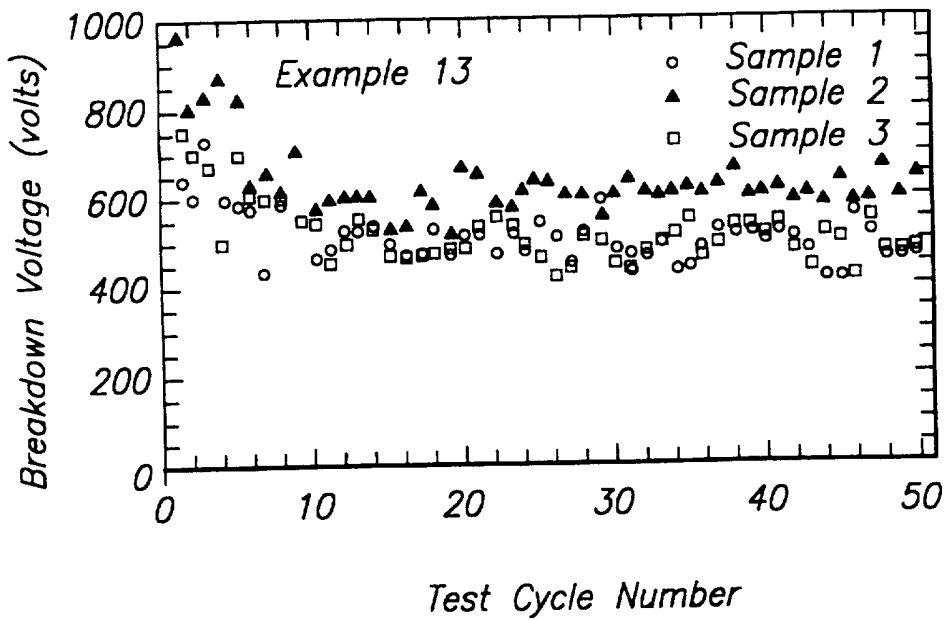

FIG. 5b

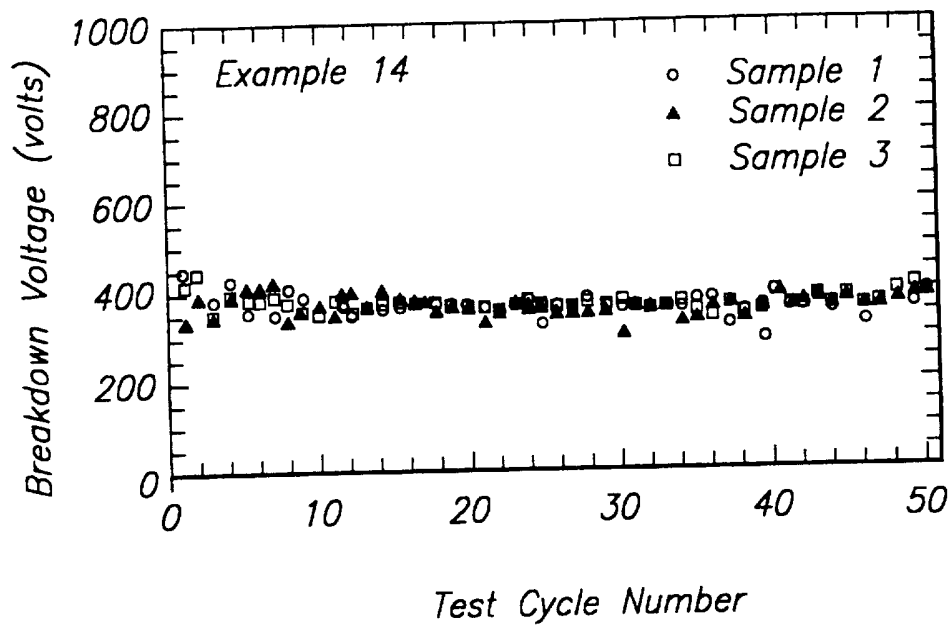

FIG. 5c

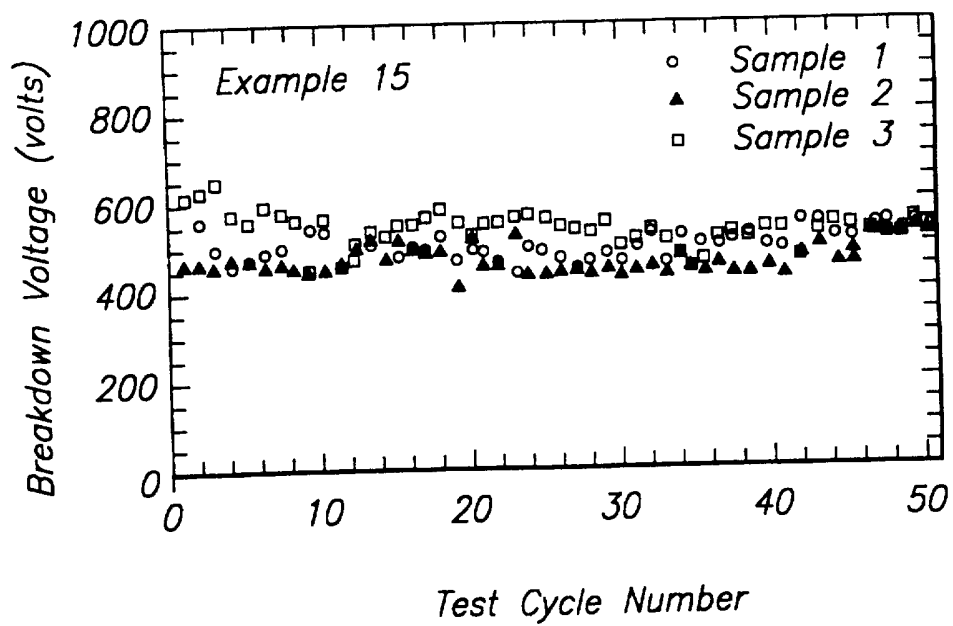

FIG. 5d

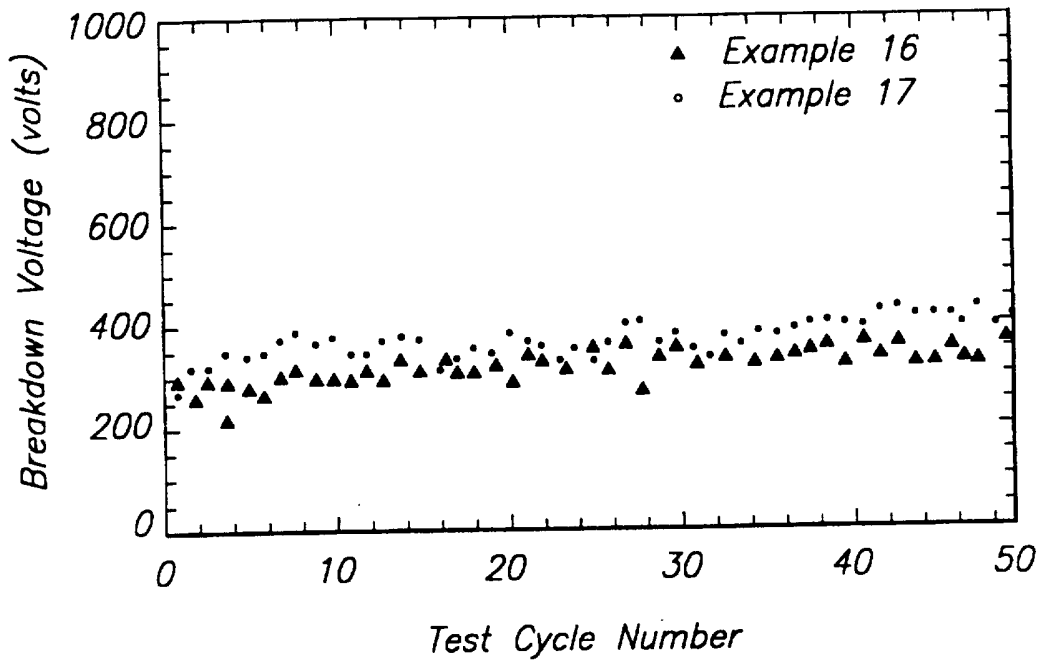

FIG. 6

INTERNATIONAL SEARCH REPORT

International Application No
PCT/US 96/19319

A. CLASSIFICATION OF SUBJECT MATTER
IPC 6 H01C7/02

According to International Patent Classification (IPC) or to both national classification and IPC

B. FIELDS SEARCHED

Minimum documentation searched (classification system followed by classification symbols)

IPC 6 H01C

Documentation searched other than minimum documentation to the extent that such documents are included in the fields searched

Electronic data base consulted during the international search (name of data base and, where practical, search terms used)

C. DOCUMENTS CONSIDERED TO BE RELEVANT

Category *	Citation of document, with indication, where appropriate, of the relevant passages	Relevant to claim No.
A	US 5 106 540 A (BARMA PRADEEP ET AL) 21 April 1992 see claims ---	1,2,6,8
A	US 4 101 862 A (TAKAGI KATSUYUKI ET AL) 18 July 1978 see the whole document ---	1,2,6
A	US 3 974 105 A (SATO KUNIO ET AL) 10 August 1976 see column 2, line 44 - column 3, line 11; figure 8 ---	1,2,6
A	WO 86 01634 A (RAYCHEM CORP) 13 March 1986 cited in the application see the whole document ---	1-10
	-/--	

Further documents are listed in the continuation of box C.

Patent family members are listed in annex.

* Special categories of cited documents :

- *A* document defining the general state of the art which is not considered to be of particular relevance
- *E* earlier document but published on or after the international filing date
- *L* document which may throw doubts on priority claim(s) or which is cited to establish the publication date of another citation or other special reason (as specified)
- *O* document referring to an oral disclosure, use, exhibition or other means
- *P* document published prior to the international filing date but later than the priority date claimed

- *T* later document published after the international filing date or priority date and not in conflict with the application but cited to understand the principle or theory underlying the invention
- *X* document of particular relevance; the claimed invention cannot be considered novel or cannot be considered to involve an inventive step when the document is taken alone
- *Y* document of particular relevance; the claimed invention cannot be considered to involve an inventive step when the document is combined with one or more other such documents, such combination being obvious to a person skilled in the art.
- *&* document member of the same patent family

Date of the actual completion of the international search

27 March 1997

Date of mailing of the international search report

17. 04. 97

Name and mailing address of the ISA
European Patent Office, P.B. 5818 Patentlaan 2
NL - 2280 HV Rijswijk
Tel. (+ 31-70) 340-2040, Tx. 31 651 epo nl,
Fax (+ 31-70) 340-3016

Authorized officer

Lina, F

INTERNATIONAL SEARCH REPORT

International Application No
 PCI/US 96/19319

C.(Continuation) DOCUMENTS CONSIDERED TO BE RELEVANT

Category *	Citation of document, with indication, where appropriate, of the relevant passages	Relevant to claim No.
A	US 5 294 374 A (MARTINEZ HENRY ET AL) 15 March 1994 cited in the application see the whole document -----	1-10

INTERNATIONAL SEARCH REPORT

Information on patent family members

International Application No

PCT/US 96/19319

Patent document cited in search report	Publication date	Patent family member(s)	Publication date
US 5106540 A	21-04-92	CA 1302609 A	02-06-92
		DE 3789325 D	21-04-94
		DE 3789325 T	27-10-94
		EP 0231068 A	05-08-87
		JP 2513659 B	03-07-96
		JP 62167358 A	23-07-87
		WO 8900755 A	26-01-89
-----	-----	-----	-----
US 4101862 A	18-07-78	NONE	
-----	-----	-----	-----
US 3974105 A	10-08-76	JP 1068304 C	23-10-81
		JP 50009053 A	30-01-75
		JP 56008457 B	24-02-81
		CA 1006209 A	01-03-77
		DE 2426348 A	12-12-74
		FR 2232071 A	27-12-74
		GB 1466004 A	02-03-77
NL 7407142 A,C	03-12-74		
-----	-----	-----	-----
WO 8601634 A	13-03-86	AU 4693385 A	06-03-86
		AU 4724889 A	14-06-90
		CA 1295766 A	11-02-92
		DE 3585086 A	13-02-92
		EP 0174165 A	12-03-86
		EP 0193581 A	10-09-86
		JP 7014432 A	17-01-95
		JP 7077089 B	16-08-95
		JP 6057773 B	03-08-94
		JP 61069847 A	10-04-86
		JP 62500130 T	16-01-87
		NO 174853 B	11-04-94
		US 5177143 A	05-01-93
-----	-----	-----	-----
US 5294374 A	15-03-94	NONE	
-----	-----	-----	-----