

(No Model.)

H. O. AMUNDSON.
CLOTHES LINE REEL.

No. 574,870.

Patented Jan. 12, 1897.

Fig: 1.

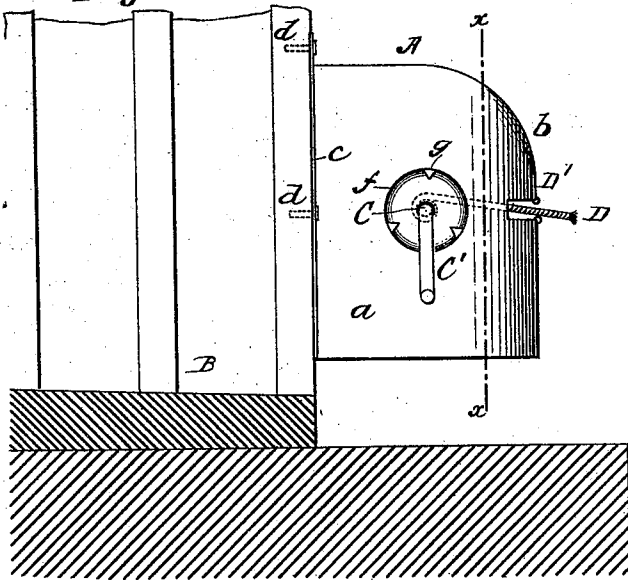

Fig: 3.

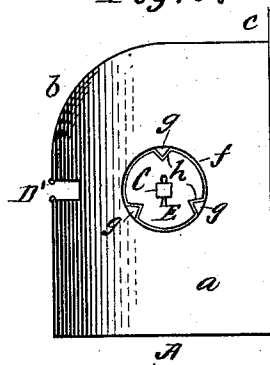
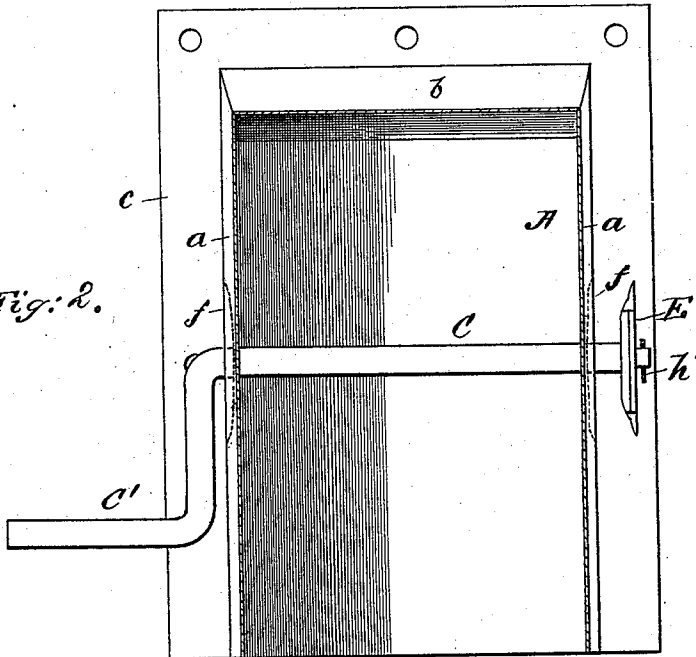

Fig: 2.



WITNESSES:

Charles Bree
H. E. Spencer

INVENTOR

Henry O. Amundson.

BY *A. A. West.*

ATTORNEY

UNITED STATES PATENT OFFICE.

HENRY O. AMUNDSON, OF CLEAR LAKE, SOUTH DAKOTA.

CLOTHES-LINE REEL.

SPECIFICATION forming part of Letters Patent No. 574,870, dated January 12, 1897.

Application filed April 1, 1896. Serial No. 585,706. (No model.)

To all whom it may concern:

Be it known that I, HENRY O. AMUNDSON, a citizen of the United States, and a resident of Clear Lake, in the county of Deuel and State of South Dakota, have invented certain new and useful Improvements in Clothes-Line Reels, of which the following is a specification.

The object of my invention is to provide a cheap and practical clothes-line reel whereby the line may be wound up and protected when not in use and whereby the slack of the line may be readily taken up when in use; and to this end my invention consists of the construction, arrangement, and combination of parts, all as hereinafter described and claimed.

In the accompanying drawings, to which reference is made, and which form a part of this specification, Figure 1 is a sectional elevation showing my invention secured to a building or other support in position for use. Fig. 2 is an enlarged sectional elevation of the same, taken on line *xx* of Fig. 1; and Fig. 3 is a side view of the device.

A represents a main frame or casing made of metal (sheet metal preferred) and formed of the side pieces *a a* and the curved top and front *b*. The edges of the top *b* and sides *a a* are formed with a flange *c*, by which the device may be secured by nails or screws *d* to a post, the side of a building B, or other suitable support.

C represents a crank-shaft journaled in openings in the sides *a a*, so as to constitute a reel to which the line D is secured, and on which it may be wound up within the casing, and by which the line may be drawn taut and all slack taken up. The line plays through a slot D' in the front of the casing. Around each of the journals of the shaft C is formed

a depression or cup *f*, at the margin of which are formed V-shaped lugs *g*, as shown clearly in Figs. 1 and 3, and on the end of the shaft C is keyed a disk E, which is formed with marginal recesses or notches *h* to receive and engage with the lugs *g* for locking the shaft C against rotation. The shaft C is adapted to be moved longitudinally in its bearings, so that the disk E, by such movement, may be moved out of engagement with the lugs *g*, as shown in Fig. 2, or moved into engagement therewith, as shown in Fig. 3.

In reeling the line either out or in the shaft C will be moved to the position shown in Fig. 2, which permits the shaft to be revolved for winding up or paying out the line, and when this is done the shaft C has simply to be moved back longitudinally to place to cause the disk E to engage the lugs *g*, whereupon the shaft will be firmly locked, so that it will firmly hold the line.

The disk E may be removed from the shaft C by removing pin *h'*, so that the shaft may be drawn out of its bearings and reversed to bring the crank C' of the shaft upon the opposite side of the casing to suit the situation in which the device is to be placed.

Having thus described my invention, what I claim as new, and desire to secure by Letters Patent, is—

As a new article of manufacture a clothes-line reel comprising a top or cover, flanged side pieces, a crank-shaft journaled in said side pieces and a notched disk keyed on said shaft, the said side pieces being provided with recesses and marginal lugs, substantially as described.

HENRY O. AMUNDSON.

Witnesses:

J. A. THRONSON,
OLE BLEGSTAD.