

(19) AUSTRALIAN PATENT OFFICE

(54) Title

Connector

(51)⁶ International Patent Classification(s)

H01R 13/62 (2006.01) 24/02
H01R 24/02 (2006.01) 20060101ALI2005100
H01R 33/20 (2006.01)⁸BMEP **H01R**
H01R 13/62 33/20
20060101AFI2005100 20060101ALI2005100
⁸BMEP **H01R** ⁸BMEP
PCT/GB2003/003080

(21) Application No: 2003254462

(22) Application Date: 2003 .07 .16

(87) WIPO No: W004/008581

(30) Priority Data

(31) Number	(32) Date	(33) Country
0216448.1	2002 .07 .16	GB

(43) Publication Date : 2004 .02 .02

(43) Publication Journal Date : 2004 .03 .18

(71) Applicant(s)

Graham Mcleish

(72) Inventor(s)

McLeish, Graham

(74) Agent/Attorney

Graham John Mcleish, Suite 2148, 9 Tanbark Circuit, Wellington Downs, NSW, 2747

(56) Related Art

GB 2162701

FR 2808624

US 5971810

EP 0922426

FR 2625847

US 5401175

US 6283767

MOD EXAM GB GRANT 2406723

FR 2638907

(19) World Intellectual Property
Organization
International Bureau



(43) International Publication Date
22 January 2004 (22.01.2004)

PCT

(10) International Publication Number
WO 2004/008581 A1

- (51) International Patent Classification⁷: **H01R 13/62**, 24/02, 33/20
- (21) International Application Number:
PCT/GB2003/003080
- (22) International Filing Date: 16 July 2003 (16.07.2003)
- (25) Filing Language: English
- (26) Publication Language: English
- (30) Priority Data:
0216448.1 16 July 2002 (16.07.2002) GB
- (71) Applicant and
(72) Inventor: **MCLEISH, Graham** [GB/GB]; Woolmill
Croft, Ardlethen, Ellon AB41 8JB (GB).
- (81) Designated States (*national*): AE, AG, AI, AM, AT, AU, AZ, BA, BB, BG, BR, BY, BZ, CA, CH, CN, CO, CR, CU, CZ, DE, DK, DM, DZ, EC, EE, ES, FI, GB, GD, GE, GI, GM, HR, HU, ID, IL, IN, IS, JP, KE, KG, KP, KR, KZ, LC, LK, LR, LS, LF, LU, LV, MA, MD, MG, MK, MN, MW, MX, MZ, NO, NZ, OM, PH, PL, PT, RO, RU, SC, SD, SE, SG, SK, SL, TJ, TM, TN, TR, TT, TZ, UA, UG, US, UZ, VC, VN, YU, ZA, ZM, ZW.
- (84) Designated States (*regional*): ARIPO patent (GH, GM, KE, LS, MW, MZ, SD, SL, SZ, TZ, UG, ZM, ZW), Eurasian patent (AM, AZ, BY, KG, KZ, MD, RU, TJ, TM), European patent (AT, BE, BG, CH, CY, CZ, DE, DK, EE, ES, FI, FR, GB, GR, HU, IE, IT, LU, MC, NL, PT, RO, SE, SI, SK, TR), OAPI patent (BF, BJ, CF, CG, CI, CM, GA, GN, GQ, GW, ML, MR, NE, SN, TD, TG).
- (74) Agent: **MURGITROYD & COMPANY**; Scotland House, 165-169 Scotland Street, Glasgow G5 8QA (GB).
- Published: — with international search report

[Continued on next page]

(54) Title: CONNECTOR

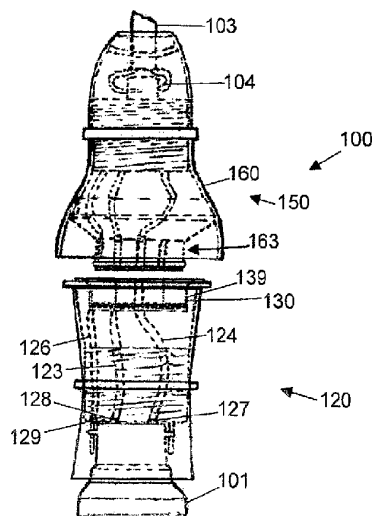

(57) Abstract: An electrical connector (100) comprising a male (120) and female (150) part, each part (120, 150) having a magnet (135, 165) adapted to attract the parts (120, 150) together to make a connection. The parts (120, 150) can connect at any relative rotational orientation and preferred embodiments prevent offset connection between the magnets (135, 165) or parts (120, 150). The connector (100) is particularly suited for use in out of reach locations, for example to easily and safely replace light bulbs into sockets suspended from a ceiling.

WO 2004/008581 A1



For two-letter codes and other abbreviations, refer to the "Guidance Notes on Codes and Abbreviations" appearing at the beginning of each regular issue of the PCT Gazette.

1 "Connector"

2

3 This invention relates to an electrical connector,
4 particularly but not exclusively for use in
5 difficult to and/or out of reach locations.

6

7 Electrical connectors are used in a variety of
8 domestic and industrial Applications. A number of
9 different connectors are known and these vary from
10 application to application, a 3-pin plug and wall
11 socket is a typical example.

12

13 There are two popular types of connector for
14 connecting light bulbs to a socket; a thread
15 connection and a bayonet connection. For the thread
16 connection, the bulb thread is rotationally aligned
17 with a thread of the socket and then screwed into
18 the socket allowing respective electric terminals on
19 the bulb and socket to connect.

20

21 The bayonet connection has pins which extend
22 radially from the bulb. The pins are aligned with
23 apertures in a circumferentially extending rim of

1 the socket and inserted therethrough against action
2 of a spring in the socket and so to allow respective
3 terminals on the bulb and socket to electrically
4 connect. The bulb is then turned so that the pins
5 move into small recesses in the rim and are no
6 longer aligned with the apertures. The action of
7 the spring engages the pins with an edge of the
8 recesses to hold the bulb in the socket and maintain
9 the electrical connection.

10

11 Although these connectors are generally competent,
12 they can be difficult to secure and release,
13 particularly in out of reach places such as sockets
14 suspended from the ceiling.

15

16 Moreover, some current light sockets are hazardous
17 because they contain exposed live electrical
18 contacts and are replaced in such out of reach
19 environments when it is often dark because the light
20 is inoperable at that moment. Inadvertent contact
21 with exposed electrical contacts can have
22 potentially fatal consequences.

23

24 A connector for a cordless kettle is described in
25 US5971810 the disclosure of which is incorporated
26 herein by reference. This connector, shown in Figs.
27 1a - 1c allow the connection between a male part 20
28 and female part 50 of the connector regardless of
29 relative rotational orientation.

30

2003254462 26 Feb 2006

1 According to the present invention there is provided
2 an electrical connector comprising a male part and a
3 female part for engagement therewith;

4 the male part comprising a first terminal
5 having a circular cross section and a second
6 terminal;

7 the female part comprising engaging means to
8 engage said terminals;

9 wherein the male and female parts each comprise a
10 magnetic portion adapted to attract the parts
11 together to form an electrical connection;
12 comprising magnetic misconnection means
13 to prevent the male and female parts from
14 connecting in a non-concentric position;
15 wherein at least some of the magnetic field or flux
16 emitted from at least one of the magnetic portions
17 extends beyond the magnetic misconnection means
18 to attract the parts together to form
19 an electrical connection.

20

21

22 Preferably, the first and second terminals are
23 concentric.

24

25 Preferably, the second terminal is a pin terminal.
26 Preferably, the second terminal has a circular cross
27 section. Preferably, the first terminal is an
28 annular terminal.

29

30 Preferably, the male or female part is attached to
31 pendent means, more preferably, the female part is
32 attached to the pendent means.

1 Preferably, the parts can engage with each other in
2 any relative rotational orientation.
3
4 Preferably, the magnetic portions have a circular
5 cross section, and are preferably in the form of an
6 annular ring.
7
8 Preferably, at least one magnetic portion is
9 provided in a recessed portion to prevent the
10 magnets from connecting in a non-concentric
11 position. Preferably, one of the male and female
12 parts comprise walls extending away from its
13 magnetic portion, the walls being adapted to prevent
14 the male and female parts from connecting in a non-
15 concentric position. Preferably, the male part
16 comprises the walls.
17
18 It will be appreciated by the skilled person that a
19 substantially concentric position is not to be
20 regarded as a non-concentric position.
21
22 Preferably, the parts seek and locate with each
23 other when brought into the vicinity of each other.
24
25 Preferably, the parts are adapted to be attracted
26 together to form an electrical connection when they
27 are between 1cm and 30cm apart.
28
29 More preferably, the parts are adapted to be
30 attracted together to form an electrical connection
31 when they are between 2cm and 30cm apart, although
32 the parts may be adapted to be attracted together to

1 form an electrical connection when they are between
2 5cm and 30cm apart. Indeed the parts may be adapted
3 to be attracted together to form an electrical
4 connection at greater distances.
5
6 Preferably, the terminals are male terminals.
7
8 Preferably, the first terminal is a neutral terminal
9 and the second terminal is a live terminal and the
10 engaging means of the female part may comprise
11 respective female neutral and live terminals.
12
13 Preferably, the neutral and live terminals of the
14 female part are enclosed. By 'enclosed' it is
15 intended to mean that they are generally
16 inaccessible except to the male terminals. This may
17 be achieved by providing narrow apertures
18 (preferably less than 3mm wide) within the female
19 part or providing a shutter means.
20
21 Optionally a male earth terminal may be provided.
22 Preferably, the earth terminal has a circular cross
23 section and is concentric with the first and second
24 terminals. More preferably, the male earth terminal
25 has a greater diameter than the other male
26 terminals.
27
28 Preferably, the female portion has a
29 circumferentially projecting portion. Preferably
30 the said projecting portion has an aperture therein
31 to receive the first male terminal. More preferably

1 the projecting portion also has an annular groove
2 therein to receive the second male terminal.
3
4 Preferably, the projecting portion is adapted to
5 extend into or around the male part, preferably, the
6 male earth terminal. More preferably, the diameter
7 of the projecting portion allows it to pivot in the
8 male part or the male earth terminal to a limited
9 extent. Even more preferably, the projecting
10 portion comprises a lip which is adapted to closely
11 fit with the male part or male earth terminal.
12 Preferably therefore, the rest of the projecting
13 portion comprises a smaller outer diameter than an
14 outer diameter of the lip.
15
16 Preferably, the projecting portion comprises a boss.
17
18 Preferably, the magnetic portion of the female part
19 has a magnetic field which extends beyond the
20 projecting portion to attract the parts together to
21 form an electrical connection.
22
23 A corresponding female earth terminal may extend
24 through the projecting portion of the female part.
25
26 Alternatively the first terminal is a pin terminal
27 and the second terminal can be a leaf terminal. In
28 alternative embodiments the pin terminal may be an
29 earth terminal. Also, a resiliently mounted shutter
30 may be provided on the female part.
31

2003254462 26 Feb 2006

1 Preferably, the male terminals are adapted to engage
2 with the female terminals so that in use, the earth
3 connection is the first to be made, then the neutral
4 connection and lastly the live connection.

5
6 Preferably, the male terminals are adapted to
7 disengage with the female terminals in the order:
8 live first, neutral second, earth last.

9
10 Preferably, the female live and neutral terminals
11 comprise a means to reduce the possibility of arcing
12 during connection and disconnection; for example the
13 female terminals may be coated with silver or silver
14 pads.

15
16 Preferably, the male and/or female terminals are
17 resilient in order such that they will maintain a
18 connection with the corresponding female/male
19 terminals. More preferably, the female terminals are
20 resilient.

21
22 Preferably, at least one part comprises guide means
23 to guide the parts together. The guide means may be
24 in the form of a tapered face.

25
26
27
28
29
30
31 Preferably, the strength of the magnet is sufficient
32 to attract the parts of the connector together. For

1 example, where at least one part of the connector is
2 connected to the pendent means and the other part of
3 the connector is brought within 8cm of the first
4 part, the parts will preferably attract each other,
5 and move towards each other and connect. Optionally,
6 even stronger magnets may be used so that the parts
7 can attract each other at distances of 12-15cm.

8

9 The strength grade may be 30 although other grades
10 may be used. The magnetic portions may be exposed
11 on the outside of the parts or may be provided
12 within a body of the parts.

13

14 Preferably, the magnetic portions are protected by
15 at least one shield and may be protected by
16 respective shields, such that when the male and
17 female parts are connected together, the shield(s)
18 is interposed between the magnetic portions. Thus,
19 when the connector is engaged, the magnets do not
20 come into direct physical contact.

21

22 Preferably, at least one of the magnetic portions is
23 provided as a replaceable cartridge.

24

25 More preferably, an aperture is provided in at least
26 one of the male and female parts through which the
27 magnetic portions may be removed and replaced.

28

29 Alternatively, a removable cap may be provided on
30 the male or female parts to allow the magnetic
31 portions to be removed and replaced.

32

1 The connector may be used to connect electrical
2 appliances to mains electrical supplies.

3
4 Alternatively one part of the connector may further
5 comprise a standard bulb fitting at one end, such as
6 a screw or bayonet, so that a bulb can be placed in
7 that one part before the connection is made, thus
8 allowing easier connection of the bulb to a
9 difficult to reach or out of reach socket since the
10 parts attract one another.

11
12 Embodiments of the present invention will now be
13 described by way of example only with reference to
14 the accompanying drawings wherein-

15 Fig. 1a is an upper perspective view of a known
16 connector in its disconnected position;

17 Fig. 1b is a lower perspective view of the
18 known connector of Fig. 1a;

19 Fig. 1c is an upper perspective view of the
20 known connector of Fig. 1a but in its connected
21 position;

22 Fig. 2a is a side view of a first embodiment of
23 a connector in accordance with the present
24 invention, in a disconnected position with an
25 attached light bulb;

26 Fig. 2b is a plan view of a female part of the
27 connector of Fig. 2a;

28 Fig. 2c is a plan view of a male part of the
29 connector of Fig. 2a;

30 Fig. 2d is a partially cut-away perspective
31 view of the female part of Fig. 2b;

1 Fig. 2e is a partially cut-away perspective
2 view of the male part of Fig. 2c;
3 Fig. 2f is a perspective view of the female
4 part of Fig. 2b;
5 Fig. 2g is a perspective view of the male part
6 of Fig. 2c;
7 Fig. 3 is a side view of the connector of Fig.
8 2a but in its connected position;
9 Fig. 4a is a side sectional view of a second
10 embodiment of a connector in accordance with
11 the present invention;
12 Fig. 4b is a side view of the connector of Fig.
13 4a;
14 Fig. 4c is a plan view of a female part of the
15 connector of Fig. 4b;
16 Fig. 4d is a plan view of a male part of the
17 connector of Fig. 4b;
18 Fig. 5a is a perspective view of the female
19 part of Fig. 4c;
20 Fig. 5b is a perspective view of the male part
21 of Fig. 4d;
22 Fig. 5c is a second perspective view of the
23 male part of Fig. 4d with a portion cut away;
24 Fig. 6a is a side view of a third embodiment of
25 a connector in accordance with the present
26 invention, in its disconnected position with an
27 attached light bulb;
28 Fig. 6b is a plan view of a female part of the
29 connector of Fig. 6a;
30 Fig. 6c is a perspective view of the female
31 part of Fig. 6b;

1 Fig. 6d is a partially cut away perspective
2 view of the female part of Fig. 6b;
3 Fig. 6e is a partially cut away perspective
4 view of a male part of the connector of Fig.
5 6a;
6 Fig. 6f is a perspective view of the male part
7 of Fig. 6e;
8 Fig. 6g is a plan view of the male part of Fig.
9 6e;
10 Fig. 7 is a side view of the connector of Fig.
11 6a but in its connected position;
12 Fig. 8 is a perspective view of the connector
13 of Fig. 6a with an attached light bulb;
14 Fig. 9a is a side sectional view of a fourth
15 embodiment of a connector in accordance with
16 the present invention, in its disconnected
17 position;
18 Fig. 9b is a side view of the connector of Fig.
19 9a;
20 Fig. 9c is a plan view of a female part of the
21 connector of Fig. 9b;
22 Fig. 9d is a plan view of a male part of the
23 connector of Fig. 9b;
24 Fig. 10 is a side sectional view of the
25 connector of Fig. 9a but in its connected
26 position;
27 Fig. 11 is a side sectional view of the
28 connector of Fig. 9a showing magnetic
29 attraction between the male and female parts;
30 Fig. 12a is a perspective view of the female
31 part of Fig. 9c;

1 Fig. 12b is a partially cut away perspective
2 view of the female part of Fig. 9c;
3 Fig. 12c is a second partially cut away view of
4 the female part of Fig. 9c;
5 Fig. 12d is a partially cut away perspective
6 view of the male part of Fig. 9d;
7 Fig. 12e is a perspective view of the male part
8 of Fig. 9d;
9 Fig. 12f is a second partially cut away view of
10 the male part of Fig. 9d;
11 Fig. 13 is an enlarged view of the female part
12 of the connector of Fig. 12c;
13 Fig. 14 is a sectional view of a male part of a
14 fifth embodiment of a connector in accordance
15 with the present invention;
16 Fig. 15 is a sectional view of a female part of
17 the embodiment of Fig. 14;
18 Fig. 16 is a sectional view of the male and
19 female parts of the connector of Figs. 14 and
20 15 in a connected position;
21 Fig. 17a is a sectional view of a pair of ring
22 magnets approaching each other;
23 Fig. 17b is a sectional view of the ring
24 magnets of Fig. 17a in a concentrically
25 connected position;
26 Fig. 18a is a sectional view of a pair of ring
27 magnets also approaching each other but at a
28 different angle than the ring magnets of Fig.
29 17a;
30 Fig. 18b is a sectional view of the ring
31 magnets of Fig. 18a in an offset connected
32 position;

1 Fig. 19 is a further sectional view of a pair
2 of ring magnets approaching each other;
3 Figs. 20a-20d are a series of front views
4 showing the male and female parts of the Fig.
5 4a connector, connecting with each other;
6 Figs. 20e-20f are a pair of front views showing
7 the male and female parts of the Fig. 4a
8 connector disconnecting from each other;
9 Fig. 21 is a perspective view of a cartridge
10 and magnet of the fourth embodiment of the
11 invention; and
12 Fig. 22 is a top view of the cartridge and
13 magnet of Fig. 21.

14
15 A known connector 10 is shown in Figs. 1a-1c and is
16 disclosed in more detail in US 5,971,810 the
17 disclosure of which is incorporated herein by
18 reference. The connector 10 comprises a male part
19 20 adapted to mate and form an electrical connection
20 with a female part 50. The male part 20 comprises a
21 live central pin terminal 21, and first neutral 22
22 and second earth 23 annular terminals. The female
23 part comprises a boss 63 which projects from a body
24 60 of the female part 50, a central aperture 61 for
25 receiving the pin terminal 21 and an annular recess
26 62 for receiving the annular terminal 22 of the male
27 part 20. When connected, as shown in Fig. 1c, the
28 second annular terminal 23 of the male part 20
29 locates around the boss 63 and live and neutral
30 female terminals 51, 52 are located within the
31 central aperture 61 and annular recess 62
32 respectively for electrical connection with the

1 corresponding male terminals 21, 22. An earth
2 terminal 53 is provided through a side wall 64 of
3 the boss 63 to connect with the annular earth
4 terminal 23 of the male part 20. All male and female
5 terminals 21-23, 51-53 are attached to spade
6 connectors 31-33, 71-73 respectively and in turn to
7 electrical appliances or powers sources (not shown).

8
9 A first embodiment of a connector 100 in accordance
10 with the present invention is shown in Fig. 2a. The
11 connector 100 comprises a male part 120 adapted to
12 mate and form an electrical connection with a female
13 part 150. A light bulb 101 is attached to the male
14 part 120 at the opposite end of the connection with
15 the female part 150 by any known means, in this
16 embodiment, by a bayonet fitting 102, and can be
17 removed and replaced when required by such known
18 means. The male part 120, shown in plan view in
19 Fig. 2c, comprises a body 130 having a central pin
20 terminal 121, and first 122 and second annular
21 terminals 123. The three terminals 121-123 are
22 concentric.

23
24 In this embodiment the pin terminal 121 of the male
25 part 120 is connected to a live terminal 127 of the
26 standard connector 102 by wire 124 and the first and
27 second annular terminals 122, 123 to neutral 128 and
28 earth 129 terminals of the connector 102
29 respectively, also by wire 125, 126. It will be
30 appreciated that some light fittings do not have
31 earth connections and so their inclusion is
32 optional. The male part 120 includes a tapered

1 surface 140 to facilitate location with the female
2 part 150.
3
4 The female part 150 is suspended from a ceiling (not
5 shown) by a pendent or cable 103 and secured to the
6 cable 103 by a cable clamp 104. The female part
7 comprises a boss 163 which projects from a body 160,
8 a central aperture 161 for receiving the pin
9 terminal 121 and an annular recess 162 for receiving
10 the first annular terminal 122 of the male part 120.
11
12 The boss 163 has a lip 168 which extends
13 circumferentially outwards therefrom such that the
14 diameter of the boss 163 with the lip 168 is greater
15 than the diameter of the boss 163 without the lip
16 168. The lip 168 is sized to closely fit with the
17 second annular terminal 123 and thus helps to align
18 the parts 120, 150 together. The smaller diameter
19 of the remaining portion of the boss 163 allows the
20 parts 120, 150 to connect when they are at an angle
21 to each other, and for the boss 163 to pivot within
22 the annular earth terminal 123 into axial alignment
23 with the male part 120.
24
25 When connected, as shown in Fig. 3, the second
26 annular terminal 123 of the male part 120 locates
27 around the boss 163. Female terminals 151, 152 are
28 located within the central aperture 161 and annular
29 recess 162 for electrical connection with the
30 corresponding male annular terminals 121, 122. An
31 earth terminal 153 is provided through a side wall

1 164 of the boss 163 to connect with the second
2 (earth) annular terminal 123 of the male part 120.
3
4 The terminals in the female part 150 are spring
5 loaded to maintain the connection between the
6 respective male and female terminals and adapted so
7 that a connection forms between the respective earth
8 terminals 123, 153 then between the neutral
9 terminals and then between the live terminals when
10 the male 120 and female 150 parts are connected.
11 Conversely, when the connection between the male 120
12 and female 150 parts is broken, the live terminals
13 121, 151 are adapted to disengage first, then the
14 neutral terminals 122, 152 and lastly the earth
15 terminals 123, 153. This ensures that sparking or
16 arcing is minimised during connection and
17 disconnection of the parts of the connector so that
18 it is safe to use. Also, the male live and neutral
19 connections are surrounded by the earth terminal 123
20 which reduces the possibility of electrocution when
21 connected. The live 151 and neutral 152 terminals
22 of the female part 150 are also safely enclosed
23 within the female part 150 in line with British
24 safety regulations. In order to further reduce the
25 possibility of arcing during
26 connection/disconnection of the parts 120, 150; the
27 live 151 and neutral 152 terminal of the female part
28 150 are coated with silver or have silver pads.
29
30 A magnetic ring 135 is secured by spring clips (not
31 shown) or any other suitable means to the male part
32 120 between the first annular terminal 122 and the

2003254462 26 Feb 2006

1 second (earth) annular terminal 123. An oppositely
2 attracting magnetic ring 165 is secured between the
3 annular recess 162 and an edge 166 of the boss 163
4 of the female part 150, as shown in Fig. 2f. A
5 suitable heat resistant glue may also be used to
6 secure the magnetic rings 135, 165 to the parts 120,
7 150 although this is less preferred.

8
9 The magnetic ring 135 is provided in a recessed
10 portion of the male part 120 such that the boss 163
11 of the female part 150 must extend into the male
12 part 120 in order for the magnets to engage. This
13 prevents the magnets joining in an offset position
14 and is explained more thoroughly hereinafter.

15
16 In this embodiment the magnetic rings are annular
17 rings and around 1.5mm thick and have an outer
18 diameter of 27mm and a central aperture of diameter
19 15mm although it will be appreciated that a variety
20 of sizes may be used. A further embodiment has a
21 diameter of 28mm and a central aperture of 16mm for
22 the female part 150. The magnetic rings 135, 165
23 are powerful enough to attract the parts 120, 150 of
24 the connector 100 at a distance of up to 8cm. For
25 stronger magnetic rings, the parts may attract each
26 other at a distance of 12-20 cm. However there
27 is a balance between proximity of location and ease
28 of separation for different embodiments - extremely
29 strong magnetic rings that locate one another over
30 30cm apart would be increasingly difficult to
31 separate when required. On the other hand, weak
32 magnetic rings which are easier to separate would

2003254462 26 Feb 2006

1 require the parts 120, 150 to be offered closer in
2 order to seek and locate with each other and may not
3 be powerful enough to maintain the weight of the
4 male part 120 and attached bulb 101. Therefore the
5 direction of magnetism is through depth.

6
7
8
9
10 For other
11 embodiments, for example, those used in industrial
12 applications, the strength grade may be higher.

13
14
15
16
17
18
19
20

21 The magnetic rings are
22 available from Swift Levick Magnets Ltd, Barlborough
23 UK; Goudsmit magnetics UK Limited of Surrey, United
24 Kingdom or the Stanford Magnets Company of Aliso
25 Viejo, California, USA. Alternatively, magnetic
26 discs instead of magnetic rings may be utilised.

27
28
29
30
31
32

In alternative embodiments, magnetic particles can
be mixed with nylon/plastic compound and injection
moulded to the appropriate shape. For example, the
boss 163 of the female connector could be formed
from a mixture of magnetic particles and

1 plastic which has been moulded to an appropriate
2 shape. In such an embodiment, the magnetic
3 particles are preferably distributed close to the
4 edge of the boss such that it behaves similar to a
5 separate boss and magnet attached together such as
6 the boss 163 and magnet 165.

7
8 Pole pieces (not shown) may be provided within the
9 male or female parts behind the magnets 135, 165 to
10 direct the magnetic attraction more efficiently and
11 thus aid the location of the parts 120, 150
12 together. Where pole pieces are used, the magnets
13 135, 165 may be weaker without reducing the forces
14 attracting the opposite part. Pole pieces placed at
15 the side of magnets increase the force of connection
16 with the opposite part but decrease the distance at
17 which the parts can attract each other. Therefore,
18 in preferred embodiments, the pole pieces are not
19 placed at the side of the magnets as greater
20 attraction of the parts together is normally
21 preferred to the strength of the eventual connection
22 between the parts.

23
24 Optionally, a plastic sheath (not shown) may be
25 provided over the pin terminal 121 leaving only its
26 tip exposed for electrical connection with the
27 female terminal 151. This reduces the possibility
28 of arcing between the live and neutral terminals
29 caused by metallic debris. To the same end, a
30 plastic cone (not shown) may be provided around a
31 portion of the pin terminal 121, and a tapered wall

1 (not shown) may be provided on the inner face of the
2 second annular terminal 122.
3
4 Thus, in use, the male part 120 of the connector 100
5 may be completely detached from the female part 150
6 and held in an operator's hand in the most
7 convenient position. In this position, the light
8 bulb 101 may be inserted into the socket 102 of the
9 male part 120 so that the live, neutral and earth
10 (if provided) terminals (not shown) of the bulb 101
11 connect with the respective terminals 127, 128 and
12 129 of the bayonet connector 102. The male part 120
13 with the attached light bulb 101 can then be raised
14 towards the female part 150. This may be done by
15 hand or, for example on a telescopic gripping pole
16 (not shown). When the male 120 and female 150 parts
17 are within the vicinity of each other the parts 120,
18 150 will automatically seek each other and form a
19 connection with each other (as shown in Fig. 3) due
20 to the magnetic attraction between the magnetic
21 rings 135, 165 without the need for accurate
22 alignment of the parts 120, 150 by the operator.
23 The connection of the magnetic rings 135, 165 also
24 results in the male terminals 121-123 and the female
25 terminals 151-153 connecting with each other to form
26 an electrical connection between the male and female
27 parts 120, 150. Therefore the current can flow from
28 a mains supply (not shown) through the cable 103,
29 through the female part 150, through the connection
30 formed between the female part 150 and the male part
31 120, through the male part 120, through the standard
32 connection 102 and into the bulb 101. The magnetic

1 rings 135, 165 therefore have two distinct
2 functions, one, to locate the male 120 and female
3 150 parts together, and two, to hold the parts 120,
4 150 together.

5

6 Embodiments of the present invention benefit from
7 being able to seek and locate the parts together at
8 a relatively large distance, for example, 8cm or up
9 to 20cm or more. This is in contrast to some
10 previous magnetic connectors which must be aligned
11 together by a user and where the magnetic field
12 simply holds the different parts together. A
13 variety of factors determine the distance at which
14 the parts will seek together and automatically
15 locate. These include the strength, shape and type
16 of magnets used, the presence or absence of pole
17 pieces, the weight of the suspended female part, and
18 the length of the pendent upon which the female part
19 is suspended. Preferred embodiments of the invention
20 provide for such automatic connection when the parts
21 120, 150 are at least 2cm apart.

22

23 The parts 120, 150 also locate automatically due to
24 the recessed position of the magnet 135 of the male
25 part 120 behind the wall 139 which prevents the
26 parts from joining in an offset, non-concentric
27 manner. Figs 17-19 show concentric and off-set
28 connections which are possible by a pair of ring
29 magnets 41, 42 approaching each other at an angle.
30 Magnets 41, 42, shown in Fig. 17a, produce a
31 magnetic field or flux attracting oppositely poled
32 magnets or certain metals towards them. If the

1 attractive force A which would result in a
2 concentric connection is bigger than the attractive
3 force B which would result in an offset connection,
4 then the magnets 41, 42 will connect concentrically.
5 Conversely, if the attractive force B is greater
6 than the attractive force A then the magnets will
7 connect in an offset position, as shown in Figs.
8 18a, 18b. The attractive force B is only great
9 enough to cause such offset connection when offset
10 connection zones 43 of the magnets 41, 42 overlap in
11 a non-concentric position. Lastly, as shown in Fig.
12 19a, if the magnet 42 has a wall 44, the magnet 41
13 is prevented from entering a position where the
14 attractive force B is greater than that of A and so
15 the magnets 41, 42 will always connect
16 concentrically. The provision of the magnet 135 in
17 a recessed position behind a wall 139 similarly
18 prevents the parts 120, 150 connecting in an offset
19 position because the wall 139 prevents the female
20 part 150 from entering any area where the forces
21 attracting the parts 120, 150 into an offset
22 connection are greater than those which attract the
23 parts 120, 150 into a concentric connection. Where
24 such walls are provided, the magnets should be able
25 to exert their magnetic fields beyond the walls in
26 order to attract the two parts together.
27
28 The required height of the walls 139 to prevent off-
29 set connection depends on the strength, type and
30 size of the magnets. For example, if the male part
31 120 has a ring magnet of grade 30 Neo, 22mm outside
32 diameter, 8mm inside diameter and is 10mm thick, and

1 a female part has a 2:17 grade SmCo female magnet of
2 23mm outside diameter, 17mm inside diameter and 5mm
3 thick, the separation between the magnets and the
4 end of the walls should be at least 3mm.
5 Alternatively, for a male part 120 with a grade 30
6 Neo magnet, 20mm outside diameter, 15mm inside
7 diameter and 5mm thick interacting with the same
8 female magnet, the separation should be at least
9 around 5mm. A further alternative is to have the
10 male 120 and female 150 parts each with grade 30 Neo
11 magnets 27mm outer diameter, 15mm inner diameter and
12 1.5mm thickness, the minimum separation would be
13 around 7mm.

14
15 As well as ensuring a concentric connection, the
16 length of the wall 139 should be sufficiently large
17 to provide a good mechanical connection and resist
18 accidental disconnection. Moreover, the length of
19 the wall 139 also affects the influence of the
20 magnetic flux emitted by the magnet 135 - longer
21 walls effectively increase the axial attraction
22 relative to the transverse attraction. Shorter
23 walls on the other hand effectively increase the
24 transverse attraction relative to the axial
25 attraction. Indeed it has been found that more
26 powerful magnets have a tighter flux and therefore
27 require smaller walls than some weaker magnets which
28 have a greater axial attraction. A balance between
29 axial and transverse attraction is required in order
30 for the parts to self-seek and locate together
31 without the need to be accurately aligned by the
32 user. Therefore the separation is preferably larger

1 than the minimum required to prevent off-set
2 connection - around 1cm for preferred embodiments.
3
4 Thus the operation of replacing a light bulb 101 is
5 far more convenient than those of standard bayonet
6 or screw thread connections because the more
7 difficult act of locating the pins of the bayonet
8 connection of the bulb 101 into the corresponding
9 sockets or screwing a screw threaded bulb into the
10 socket is done with hand held components in a
11 position convenient to the operator rather than the
12 out of reach or difficult to reach position where
13 the light bulb 101 is attached and eventually hung.
14
15 Certain embodiments of the invention such as the
16 connector 100 benefit from the advantage that the
17 parts 120, 150 may connect together without being
18 rotationally aligned making the connection even
19 easier to form.
20
21 Certain embodiments of the invention such as the
22 connector 100 benefit in that the parts 120, 150 of
23 the connector 100 locating each other due to the
24 interacting magnetic fields before securing the
25 parts together. Therefore where it is difficult to
26 align the male 120 and female 150 parts (for example
27 the female part being in a difficult to reach
28 position) then the operator only has to hold the
29 male part 120 with attached light bulb 101 in the
30 vicinity of the female part 150 for the parts to
31 automatically seek, locate and form an electrical
32 connection. This is in contrast to forming a

1 bayonet connection which would require bringing the
2 bulb in line with the socket, rotationally aligning
3 the bulb with the socket, pressing the bulb and the
4 socket together and twisting the bulb and socket
5 with respect to each other before releasing; all in
6 a position which is difficult to reach. Thus the
7 use of steps, ladders or chairs in order to gain
8 access to the out of reach socket/female part 150 is
9 required less frequently for embodiments of the
10 invention due to their ease of connection when
11 compared with known sockets.

12
13 The nature of some ring magnets may make them
14 susceptible to attract each other and join offset,
15 in a non-concentric position. However certain
16 embodiments of the invention, such as the connector
17 100, benefit in that the magnetic rings cannot
18 misalign in such a manner because the magnet 165 on
19 the female part 150 cannot access the magnet 135 due
20 to the wall 139 unless it locates in a concentric
21 position. Thus such an advantage further eases the
22 location of the male 120 and female 150 parts for
23 certain embodiments.

24
25 A second embodiment of a connector 200 in accordance
26 with the invention is shown in Figs. 4a-4d, 5a-5c
27 and 20a-20f. The second embodiment is largely
28 similar to the first embodiment 100 and like parts
29 will not be described further. The major difference
30 with the embodiment described so far is that a male
31 part 220 part of the connector 200 is in turn

1 connected to any electrical appliance (not shown)
2 rather than a light bulb 101.

3
4 Thus embodiments of the invention, such as the
5 connector 200, have the additional benefit in that
6 they can provide a socket to a mains supply (not
7 shown) for use with any type of electrical
8 appliance, for example buffers, vacuum cleaners or
9 industrial electrical appliances.

10
11 The connector 200 comprises a female part 250
12 suspended from a cable or pendent 203. The male
13 part 220 being attached to the appliance via a cable
14 205 may be offered up to the female part 250 and the
15 respective parts 220, 250 can seek and make a
16 connection as described for the first embodiment.

17
18 The male part 220 of the connector 200 also has a
19 lip 268 on a boss 263 of the female part for close
20 fitting with an second annular terminal 223 of the
21 male part 220. The reduced diameter of the
22 remaining part of the boss 263 compared to that
23 around the lip 268 allows for the boss 263 to pivot
24 to a limited extent within the second annular
25 terminal 223 of the male part 220. Figs. 20a-20f
26 show the male 220 and female 250 parts of the
27 connector being assembled and disassembled. The
28 female part 250 is suspended from a cable 203 and
29 the male part 220 is brought into its vicinity by a
30 user 206. The interactive attraction between
31 respective magnets 235, 365 (not shown in Figs. 20a-
32 20f) on the male 220 and female 250 parts

1 respectively causes the female part 250 to swing
2 towards the male part 220 and for the boss 263 to
3 travel within the male part 220. A tapered surface
4 (not shown) and walls 239 on the male part help to
5 guide the boss 263 into the male part 220. As can
6 be seen from the diagram, the parts 220, 250 connect
7 at an angle to each other and would do so in most
8 instances in practice unless the parts 220, 250 are
9 offered up in axial alignment. Thus the ability to
10 connect together at an angle is an important feature
11 of preferred embodiments of the invention. The
12 reduced diameter of the boss compared with that of
13 the second annular terminal allows for such angled
14 connection. The slightly increased diameter at the
15 lip 268 helps to centre the boss 263 in the second
16 annular terminal 223. Electrical contacts 221-223,
17 251-253 and magnets 235, 265 then connect as
18 described in respect of the first embodiment and as
19 shown in Fig. 20d. To disassemble the connector
20 200, a user prises apart the parts 220, 250
21 typically resulting in the male part 220 being
22 released from the female part at an angle, since it
23 is easier to first break the magnetic connection at
24 one side rather than breaking the whole of the
25 connection at once. The diameter of the boss 263
26 also provides for an angled disconnection, Figs.
27 20e, 20f.

28
29 In common with other preferred embodiments, the
30 electrical contacts are arranged to connect in the
31 order: earth, neutral, live and to disconnect in the
32 order: live, neutral, earth for safe working and to

1 reduce the possibility of sparking or arcing. Even
2 when connected at an angle, as shown in Figs. 20a-
3 20f, such an order of connection and disconnection
4 of the respective terminals is maintained.

5
6 Optionally the male part 220 could be suspended from
7 the cable 203 and the female part 250 brought into
8 its vicinity but this is less preferred since the
9 live contacts in the male part would be exposed
10 which may be against safety regulations. Thus an
11 advantage of certain embodiments of the present
12 invention is that they are far safer to use than
13 previous light sockets because the live contacts are
14 enclosed within the female part and only accessible
15 through narrow apertures (preferably, less than 3mm
16 wide).

17
18 Whereas an earth connection for the first embodiment
19 of the invention was optional, an earth connection
20 for the second embodiment is preferred. The
21 annular earth terminal 223 of the male part is shown
22 in Figs. 4a, 4b, and is connected to an earth
23 terminal (not shown) of the appliance via a wire
24 226.

25
26 Where an earth connection is provided for the second
27 embodiment of the invention but not for the first
28 embodiment of the invention, it is anticipated that
29 the first embodiment of the invention could have a
30 face 166 of the magnetic ring 165 of the female part
31 160 south poled whereas a face 266 of a magnetic
32 ring 265 of the female part 260 of the second

1 embodiment 200 could be North poled. Corresponding
2 magnetic rings 136, 236 on the male parts 120, 220
3 would be oppositely poled so that a male part 220
4 belonging to the second embodiment 200 and having an
5 earth connection would connect only to a female part
6 260 of the same embodiment which also has an earth
7 connection but be repelled by the female part 160
8 belonging to the first embodiment of the invention
9 which has no earth connection. Conversely a male
10 part 120 belonging to the first embodiment 100 and
11 having no earth connection would connect only to a
12 female part 160 of the same embodiment which also
13 has no earth connection but be repelled by the
14 female part 260 belonging to the second embodiment
15 of the invention which has an earth connection.
16 This would add an extra safety feature to the
17 connectors 100, 200 to ensure the respective male
18 parts 120, 220 are connected to the correct female
19 parts 160, 260 respectively.

20

21 Third and fourth embodiments of connectors 300, 400
22 in accordance with the invention are shown in Figs.
23 6a-6g, Fig. 8 and Fig. 9a-9d respectively. These
24 embodiments 300, 400 correspond with the first 100
25 and second 200 embodiments of the invention and
26 differ in the position and size of magnetic rings
27 used.

28

29 The connector 300 comprises a magnetic ring 365
30 which is embedded in a female part 350 of the
31 connector 300, as best shown in Fig. 6d. The
32 magnetic ring 365 is around 5mm in depth. A second

1 magnetic ring 335 is mounted behind a body 330 of
2 the male part 320 in order to protect the second
3 magnetic ring 335 from connecting impact damage,
4 accidental damage or rusting by the body 330 of the
5 male part 320. A non-magnetic shield 338 is
6 provided between the magnet 335 and the end of the
7 male part 320. The magnetic ring 335 is around 10mm
8 in depth. However, the depth of the magnetic ring
9 335 may be increased without increasing the size of
10 annular rings 322, 323 to allow a boss 363 to enter
11 therebetween. The magnetic ring 365 of the female
12 part 350 may additionally or alternatively be
13 embedded within the female part 350 behind a similar
14 shield (not shown) for the same reasons. In such
15 embodiments the magnetic rings 365, 335 being
16 thicker than the corresponding magnetic rings of the
17 first and second embodiments, can provide a stronger
18 magnetic field and increase the distance between
19 which the parts 320, 350 of the connector 300 can
20 locate each other. Thus when the parts 320, 350 are
21 in their connected position the magnets will self-
22 align, as for previous embodiments, but will not
23 connect face to face due to the shield 338. Fig. 7
24 shows the connector 300 in its connected position.
25
26 The connector 400 also has the thicker magnetic
27 rings 435, 465. The typical magnetic fields created
28 by the annular magnets 435, 465 is shown in Fig. 11
29 and the connector 400 in its connected position is
30 shown in Fig. 10 and further views are shown in
31 Figs. 12a-12 & 13.
32

2003254462 26 Feb 2006

1 A significant advantage of certain embodiments of
2 the invention, such as the third and fourth
3 embodiments, is that any brittle magnets
4 are protected by shields making them less liable to
5 chipping, breakage or other connection impact
6 damage. Thus, the male 335 and female 365 magnets
7 will never come into direct contact even when the
8 parts 320, 350 have connected because they will
9 remain spaced apart by the shield(s) 338. The
10 shield(s) 338 may be made from, for example, any
11 suitable plastic and are also preferably designed to
12 absorb the high impact shock when the two parts
13 engage with each other. Although providing shields
14 338 will reduce the magnetic attraction and strength
15 of the connection between the magnets 335, 365 it
16 has been found that this does not prevent the male
17 and female parts, such as the parts 320, 350,
18 seeking and locating with each other. Moreover,
19 less metallic dust or debris will be attracted into
20 the connector 300, 400 if the magnets are spaced
21 away from the outer periphery of the parts 320, 350.

22
23 The height of the shield 338 should also be taken
24 into account when determining the necessary height
25 of walls. Thus, as described above, where a
26 separation of at least 3mm is required to prevent
27 the magnets joining in an off-set position, the
28 walls need only be, for example 2mm, if the shield
29 is 1mm thick.

30

1 The magnet 435 is provided in a cartridge 449 (shown
2 in Figs. 10, 11, 21 and 22) which can be slotted in
3 and out of the male part 420 of the connector 400.
4 The cartridge 449 has clips 448 to secure it into
5 the male part 420. Alternatively a male body 430 of
6 the male part 420 can comprise a releasable cap (not
7 shown) which itself comprises walls 439 and a shield
8 438 which is removable from the rest of the male
9 body 430 to provide access to the magnet 435. This
10 can allow for easy cleaning of the connector 400
11 since any metallic dust or debris which has
12 collected on the shield(s) 438 will be released
13 therefrom when the magnet 435 is removed. The
14 magnet 435 can also be conveniently replaced with
15 new magnets or magnets of a more suitable strength
16 for particular applications. Similar cartridges
17 (not shown) may be used to slot into the female part
18 450 although cartridges are particularly useful for
19 the male part 420 as it is more likely to gather
20 debris because it is normally a hand-held component
21 whereas the female part 450 which is normally
22 suspended from a pendent.

23
24 A fifth embodiment 500 in accordance with the
25 present invention is shown in Figs. 14-16 and
26 comprises a male part 520 and female part 550. A
27 comparable connector is disclosed in EP0922426, the
28 disclosure of which is incorporated herein by
29 reference. The fifth embodiment is similar to the
30 first and third embodiments of the invention in that
31 the male part 520 comprises a portion (not shown)
32 which is adapted to receive a light bulb and the

1 female part is connected to, and suspended from a
2 pendent (not shown).

3

4 The male part 520, shown in Fig. 14, comprises a
5 ring magnet 535, a central pin earth terminal 521,
6 spring neutral and live terminals 522, 523, and a
7 cylindrical abutment 532; all housed within an outer
8 casing 530.

9

10 The female part 550, shown in Fig. 15, comprises a
11 spring contact finger 551 and annular terminals 552,
12 553 for respective connection with the terminals
13 521-523 of the male part 520. The female part also
14 includes an oppositely poled ring magnet 565, a
15 shutter 556, a spring 557 and a hollow post 555 with
16 an aperture 554; all housed within an outer casing
17 560.

18

19 In use, the female part 550 is suspended by the
20 cable. The male part 520 is brought into proximity
21 with the suspended female part 550 and their
22 oppositely poled magnets 535, 565 attract each
23 other. This causes a circular shaped bottom face
24 531 of the abutment 532 to abut with the shutter 556
25 of the female part 550. The shutter 556 is
26 depressed into the outer casing 560 of the female
27 part 550 against the action of the spring 557 by the
28 attraction of the respective magnetic rings 535,
29 565. Concurrently, the earth pin terminal 521 moves
30 through the aperture 554 of the post 555 and
31 connects with the spring finger 551. As the male
32 part 520 continues to move into the female part 550,

1 the spring terminals 522, 523 of the male part 520
2 connect with the annular terminals 552, 553 of the
3 female part to complete the connection. The
4 connector 500 is shown in its connected state in
5 Fig. 16.

6

7 The provision of a shutter 556 within the female
8 part 550 encloses the terminals 521-523 within the
9 female part and thus reduces the likelihood of
10 electrical shock to a user. Should the shutter 556
11 be depressed at a single point, then it will move
12 laterally, pivoting around the point 559 causing a
13 side wall 558 of the shutter 556 to abut with an
14 inner face of the casing 560 and so resist further
15 depression into the female part 550. This ensures
16 the female terminals 551-553 are not exposed unless
17 the shutter 556 is depressed at at least two
18 generally opposite points on its surface.

19

20 It is clear from the foregoing description that the
21 earth, neutral and live terminals in any embodiment
22 may be provided as pins, springs or annular rings.

23

24 Suspending cables from the ceiling for mains power
25 supply may be safer than having the cables left
26 along the floor. Connectors in accordance with the
27 present invention would provide a straightforward
28 way in which to connect and disconnect appliances
29 from such cables. Moreover, should one trip on a
30 trailing cable the connection would break apart
31 without damage to the connection and would allow the

1 cable to give under action of the person tripping,
2 reducing the possibility of injury to that person.

3

4 Certain embodiments of the invention are useful in
5 areas where electrical power has to be made
6 conveniently and safely available but out of reach
7 for Health and Safety reasons. Certain connectors
8 in accordance with the invention may be used in
9 areas which need to be cleared quickly such as
10 hotels, schools or shopping precincts and quickly
11 connected or disconnected as required or as dictated
12 by floor movements.

13

14 Embodiments of the invention are also suitable to be
15 used not only for mains voltages but also for
16 higher, industrial level voltages, for example of
17 around 1000Volts.

18

19 Thus it will be appreciated that for certain
20 embodiments of the invention such as the connector
21 300 or 400, the magnetic rings need not come into
22 direct physical connection with each other as they
23 may be protected, for example, by providing them
24 within a body of the respective parts in order to
25 protect them from accidental damage and/or from
26 rusting. They nevertheless aid the parts' connection
27 with each other due to the attraction between their
28 respective magnetic fields.

29

30 Improvements and modifications may be made without
31 departing from the scope of the invention. For
32 example, the male (or female) part may be wired to

- 1 any other type of standard connector such as a 2 or
- 2 3 pin plug socket to allow for onward connection to
- 3 appliances having cables with such 2 or 3 pin plugs.

2003254462 26 Feb 2006

1 Claims

2

3 1. An electrical connector comprising a male part
4 and a female part for engagement therewith; the male
5 part comprising a first terminal having a circular
6 cross section and a second terminal;
7 the female part comprising engaging means to engage
8 said terminals;
9 wherein the male and female parts each comprise a
10 magnetic portion adapted to attract the parts
11 together to form an electrical connection;
12 comprising magnetic misconnection means to prevent the
13 male and female parts from connecting in a
14 non-concentric position;
15 wherein at least some of a magnetic field emitted
16 from at least one of the magnetic portions
17 extends beyond the magnetic misconnection means
18 to attract the parts together to form
19 an electrical connection.

20

21

22

23

24 2. A connector as claimed in claim 1,
25 wherein the magnetic misconnection means comprises a
26 wall extending away from the magnetic portion of one
27 of the male and female parts, the wall being adapted
28 to prevent the male and female parts from connecting
29 in a non-concentric position.

30

31

2003254462 26 Feb 2006

1 3. A connector as claimed in any preceding claim,
2 wherein at least one of the male and female parts is
3 attached to pendent means.

4
5 4. A connector as claimed in claim 3, wherein one
6 of the male and female parts is attached to pendent
7 means and the other of the male and female parts
8 comprises the wall.

9
10 5. A connector as claimed in any preceding claim,
11 wherein at least one of the magnetic portions is
12 protected by a non-magnetic shield, such that when
13 the male and female parts are connected together,
14 the shield is interposed between the magnetic
15 portions.

16
17 6. A connector as claimed in any preceding claim,
18 wherein the female part has a projecting portion
19 which is adapted to be received within the male
20 part.

21
22 7. A connector as claimed in claim 6, wherein the
23 magnetic portion of the female part has a magnetic
24 field which extends beyond the projecting portion to
25 attract the parts together to form an electrical
26 connection.

27
28 8. A connector as claimed claim 6 or claim 7,
29 wherein the projecting portion is adapted to have a
30 degree of freedom to pivot within the male part.

31

2003254462 26 Feb 2006

- 1 9. A connector as claimed in any one of claims 6
2 to 8, wherein the projecting portion comprises a
3 lip which is adapted to closely fit with the male
4 part.
5
- 6 10. A connector as claimed in any one of claims 7
7 to 9, wherein the projecting portion has at least
8 one aperture to receive at least one of the male
9 terminals.
10
- 11 11. A connector as claimed in any preceding claim,
12 wherein the first terminal is a neutral terminal and
13 the second terminal is a live terminal and the
14 engaging means of the female part comprise
15 respective neutral and live terminals.
16
- 17 12. A connector as claimed in claim 11, wherein the
18 neutral and live terminals of the female part are
19 enclosed.
20
- 21 13. A connector as claimed in claim 11 or 12,
22 wherein the neutral and live terminals of at least
23 one of the male and female parts are resilient.
24
- 25 14. A connector as claimed in any preceding claim,
26 wherein the male and female parts each include an
27 earth terminal which are adapted to engage with each
28 other.
29
- 30 15. A connector as claimed in claim 14, wherein the
31 male earth terminal is concentric with at least

2003254462 26 Feb 2006

1 one of the first and second terminals of the male
2 part.

3
4 16. A connector as claimed in claim 14 or 15,
5 wherein the male earth terminal has a greater
6 diameter than the first and second terminals of the
7 male part.

8
9 17. A connector as claimed in claim 16 when
10 dependent on any one of claims 6 to 10, wherein the
11 female earth terminal extends through a side wall of
12 the projecting portion.

13
14 18. A connector as claimed in claim 17, wherein the
15 earth terminals of the male and female part are
16 adapted to engage before any other terminals between
17 the male and female part engage when the parts are
18 being connected together, and wherein said earth
19 terminals are adapted to disengage after all said
20 other terminals have disengaged when the parts are
21 being disconnected from each other.

22
23 19. A connector as claimed in claim 18, wherein the
24 terminals are adapted to engage in the order: earth,
25 then neutral, then live when the male and female
26 parts are being connected and are adapted to
27 disengage in the order: live, then neutral, then
28 earth when said parts are being disconnected.

29
30
31
32

2003254462 26 Feb 2006

- 1
- 2
- 3
- 4
- 5
- 6 20. A connector as claimed in any preceding claim,
- 7 wherein the magnetic portions have a circular cross
- 8 section.
- 9
- 10 21. A connector as claimed in claim 20, wherein the
- 11 magnetic portions are in the form of an annular
- 12 ring.
- 13
- 14 22. A connector as claimed in any preceding claim,
- 15 wherein at least one of the male and female parts
- 16 comprise removable means to allow for the removal of
- 17 the magnetic portions.
- 18
- 19 23. A connector as claimed in claim 22, wherein the
- 20 removable means comprise an aperture provided in at
- 21 least one of the male and female parts to allow for
- 22 the removal of the magnetic portion(s).
- 23
- 24 24. A connector as claimed in claim 21 or 22,
- 25 wherein the removable means comprise a removable cap
- 26 to allow for the removal of the magnetic portion(s).
- 27
- 28 25. A connector as claimed in any preceding claim,
- 29 wherein one of the male and female parts is also
- 30 adapted for use with any type of electrical appliance.
- 31

2003254462 26 Feb 2006

- 1 26. A connector as claimed in any preceding claim,
2 wherein the male and female parts are adapted to be
3 attracted together to form an electrical connection
4 when they are between 1cm and 30cm apart.
5
- 6 27. A connector as claimed in any one of claims 1-
7 25, wherein the male and female parts are adapted to
8 be attracted together to form an electrical
9 connection when they are between 2cm and 30cm apart.
10
- 11 28. A connector as claimed in any one of claims 1-
12 25, wherein the male and female parts are adapted to
13 be attracted together to form an electrical
14 connection when they are at between 5cm and 30cm
15 apart.
16
- 17 29. A connector as claimed in any preceding claim,
18 wherein at least one of the parts comprises a
19 tapered face adapted to guide the parts together.
20
- 21 30. A connector as claimed in any preceding claim,
22 wherein the first and second terminals are
23 concentric.
24
- 25 31. A connector as claimed in any preceding claim,
26 wherein the second terminal has a circular cross
27 section.
28
- 29 32. A connector as claimed in any preceding claim,
30 wherein the second terminal is a pin terminal.
31

1 33. A connector as claimed in any preceding claim,
2 wherein the first terminal is an annular terminal.

3

4 34. A connector as claimed in any one of claims 14
5 or claims 15-33 when dependent on claim 14; wherein
6 the male earth terminal has a circular cross
7 section.

8

9 35. A connector as claimed in any one of claims 1 -
10 29, wherein the first terminal is a pin terminal and
11 the second terminal is a leaf terminal.

12

13 36. A connector as claimed in claim 35, further
14 comprising a resiliently mounted shutter.

15

16 37. A connector as claimed in any preceding claim,
17 wherein the male and female parts are adapted to
18 engage with each other in any relative rotational
19 orientation.

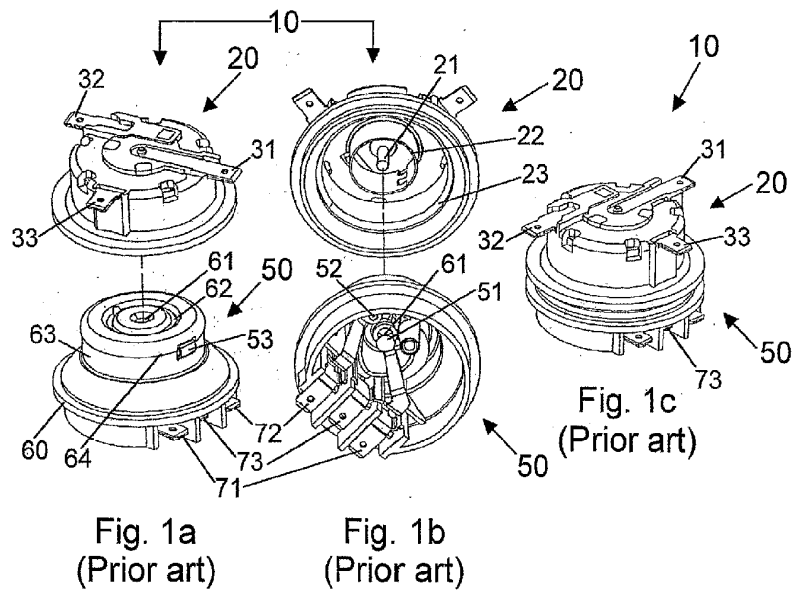

SUBSTITUTE SHEET (RULE 26)

2/17

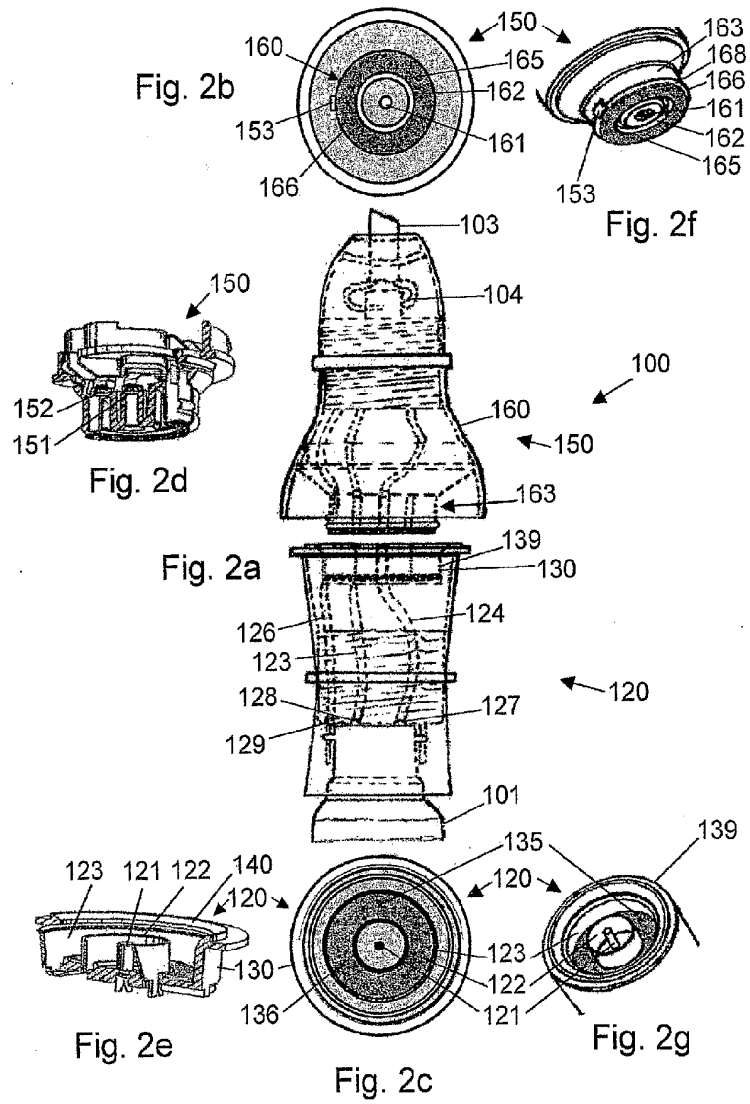

SUBSTITUTE SHEET (RULE 26)

3/17

Fig. 3

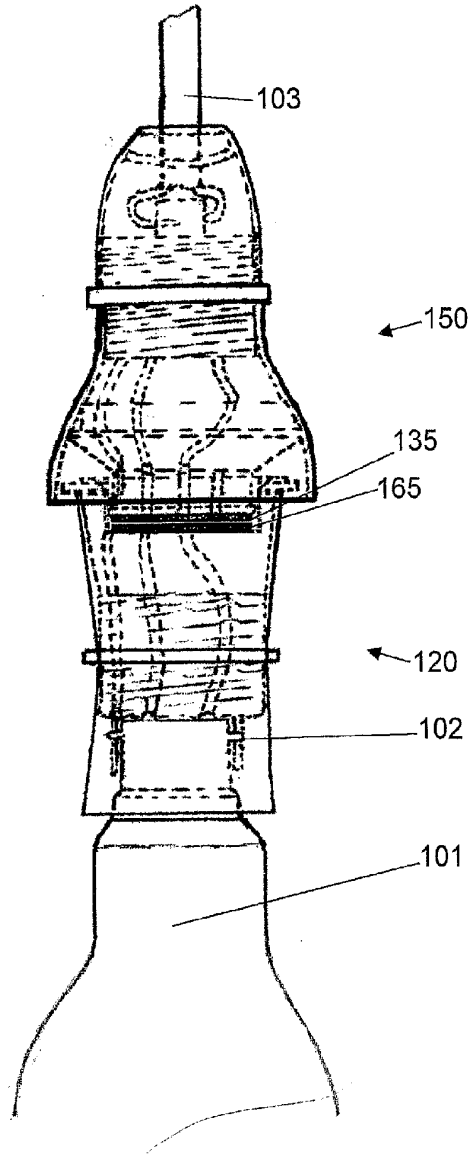

SUBSTITUTE SHEET (RULE 26)

4/17

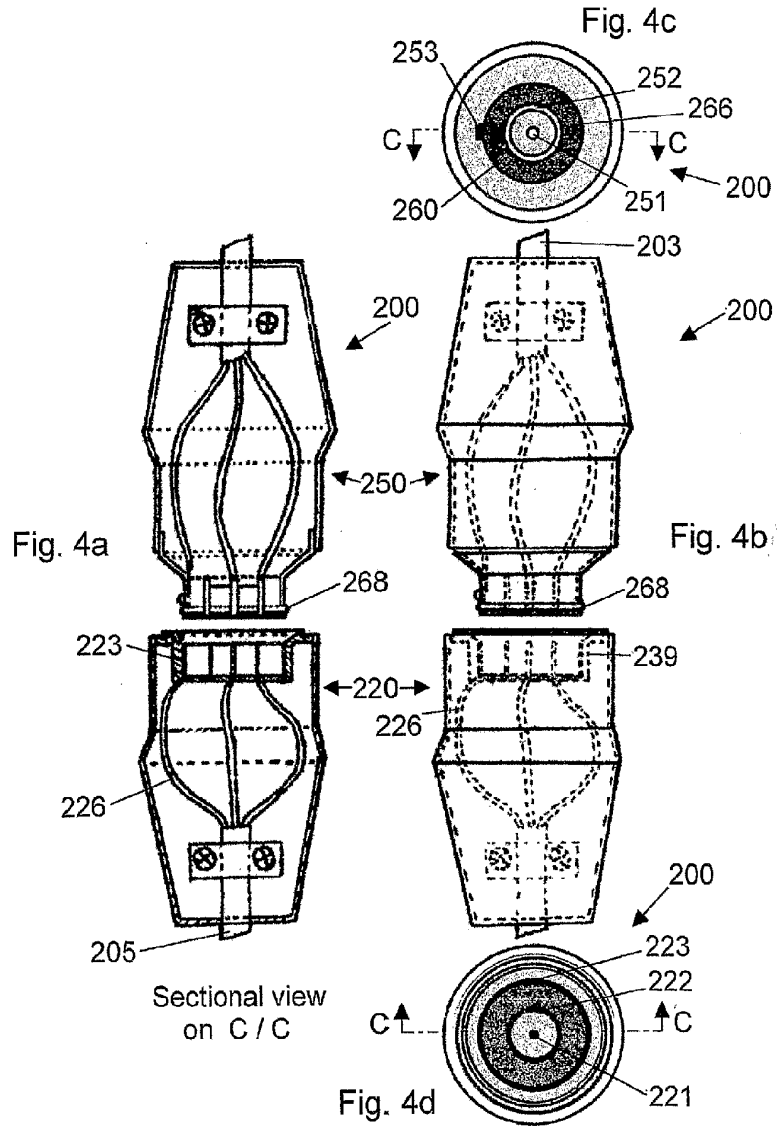

SUBSTITUTE SHEET (RULE 26)

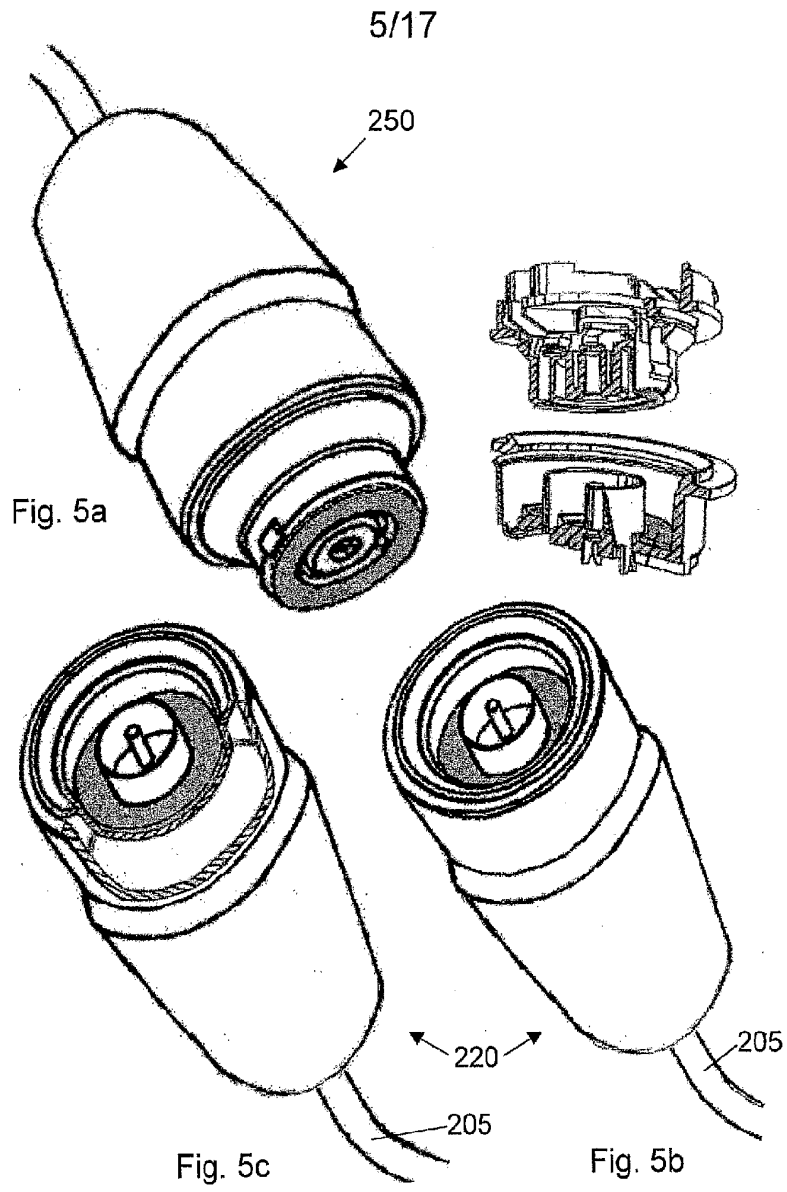

SUBSTITUTE SHEET (RULE 26)

6/17

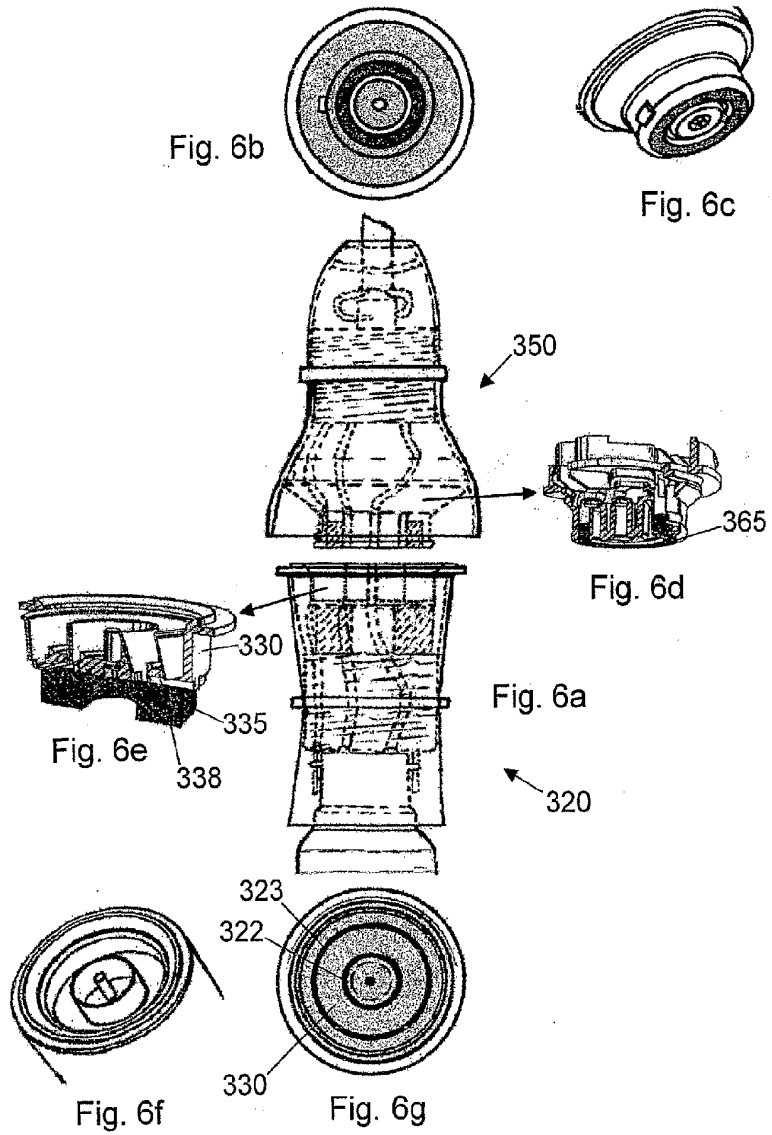

SUBSTITUTE SHEET (RULE 26)

7/17

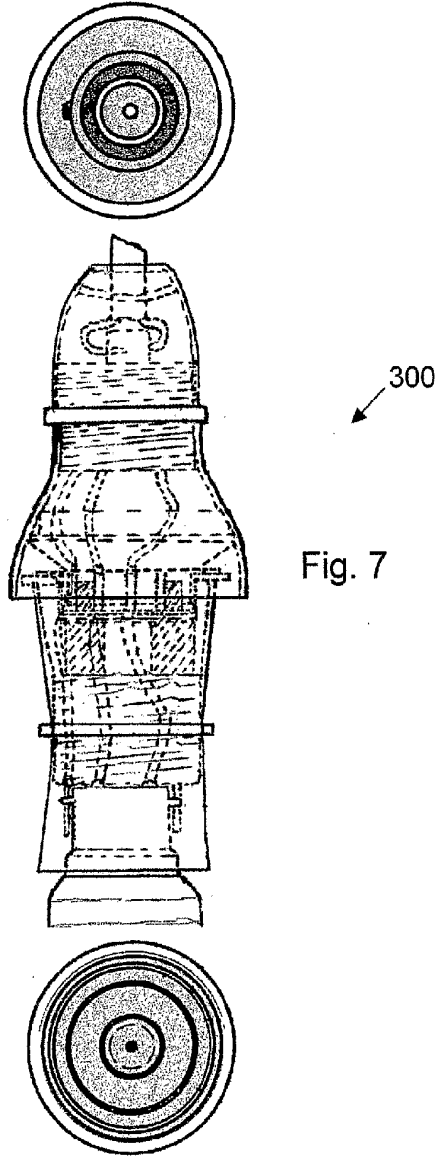

Fig. 7

SUBSTITUTE SHEET (RULE 26)

8/17

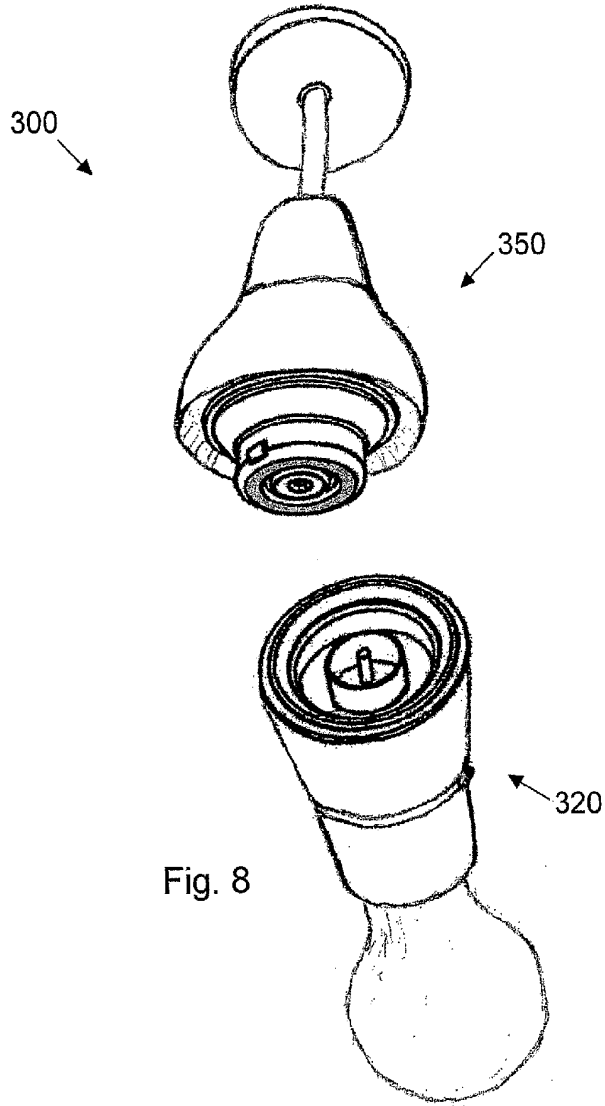
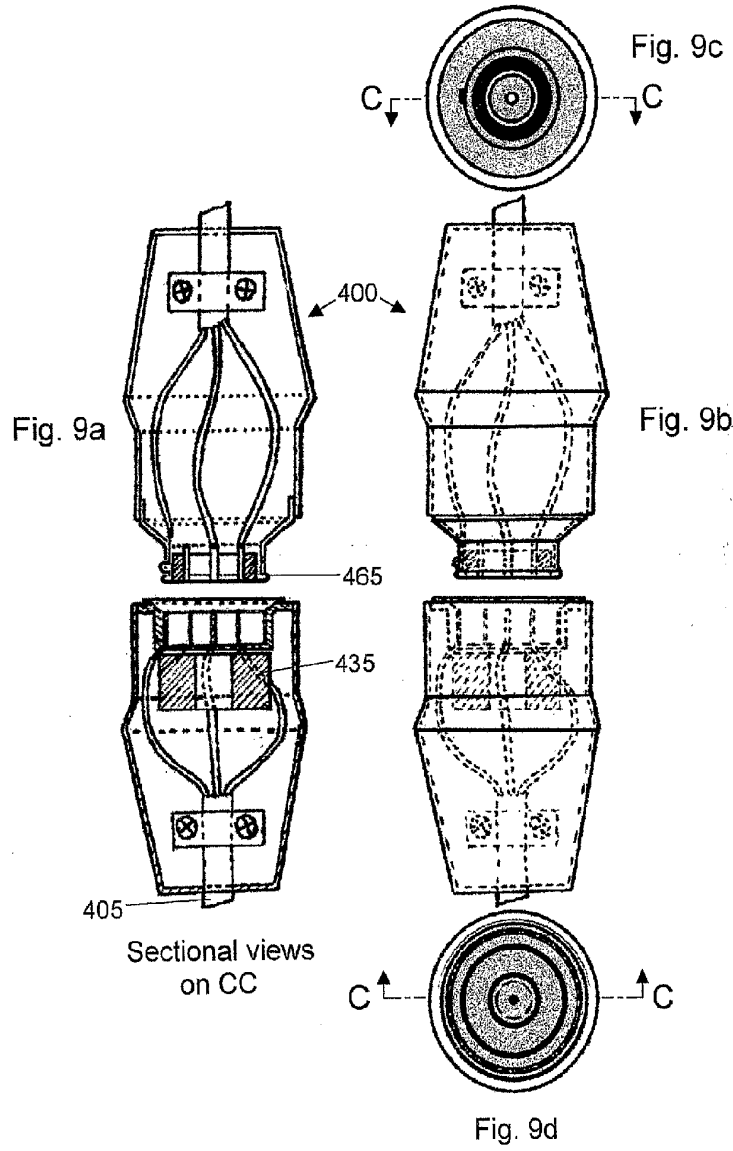

Fig. 8

SUBSTITUTE SHEET (RULE 26)

9/17



SUBSTITUTE SHEET (RULE 26)

10/17

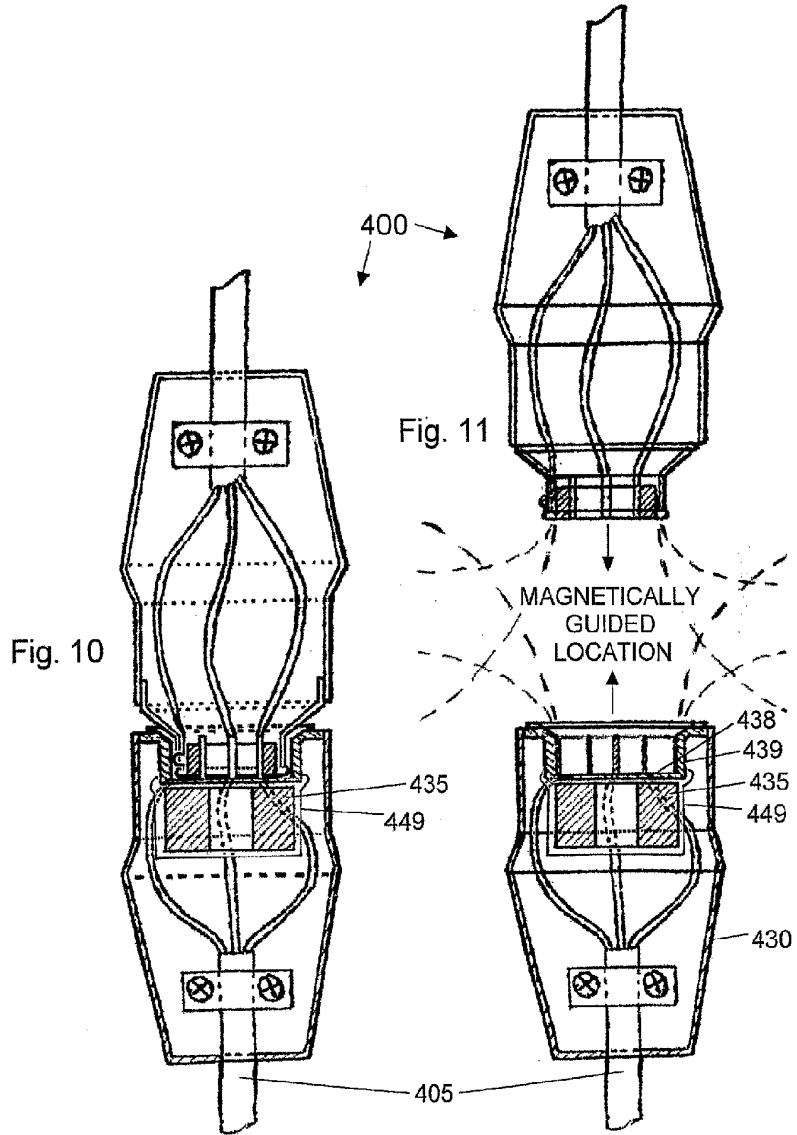

SUBSTITUTE SHEET (RULE 26)

11/17

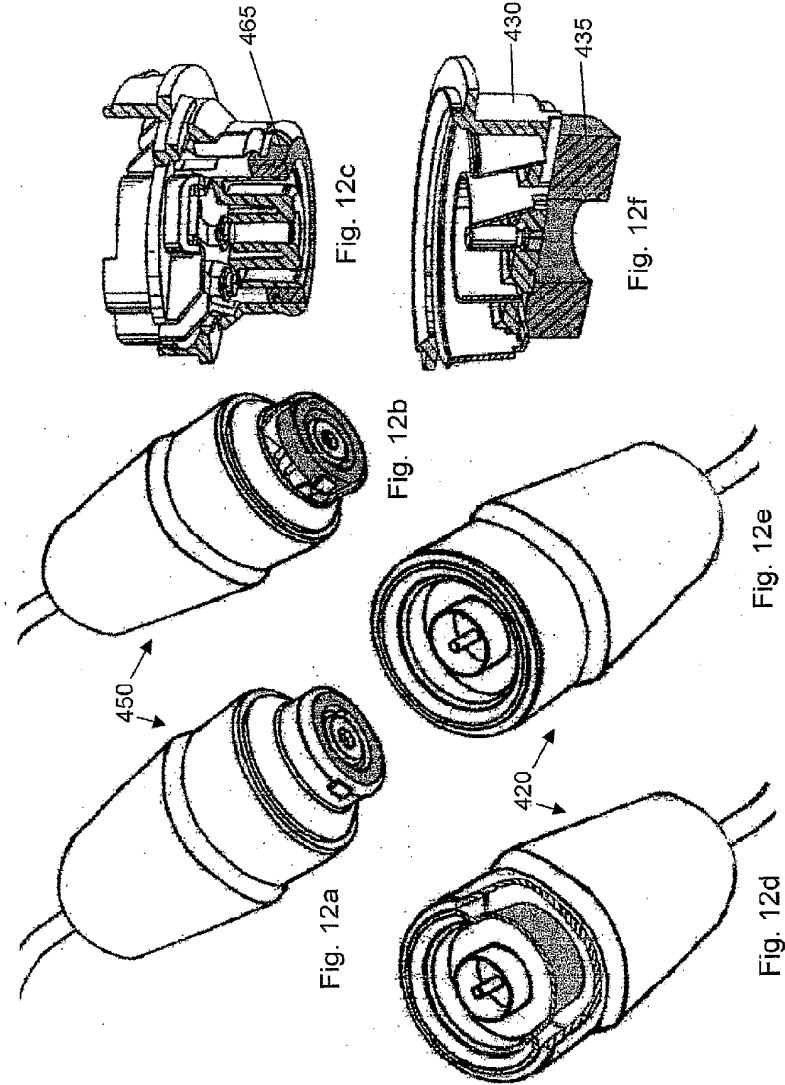

SUBSTITUTE SHEET (RULE 26)

12/17

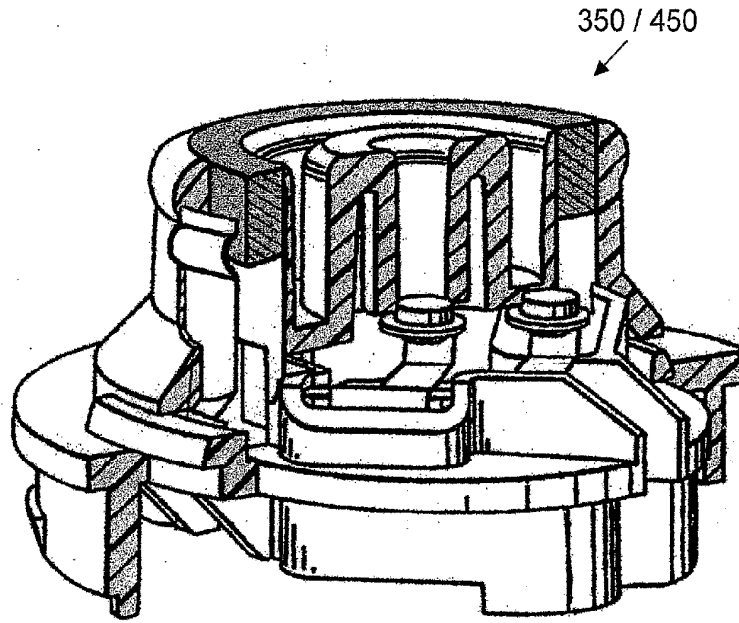

Fig. 13

SUBSTITUTE SHEET (RULE 26)

13/17

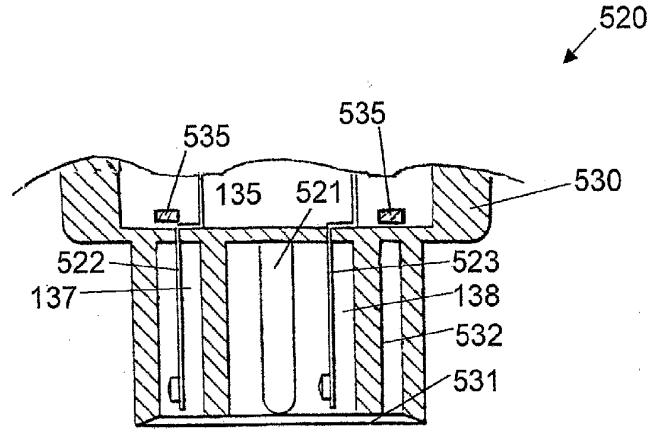

Fig. 14

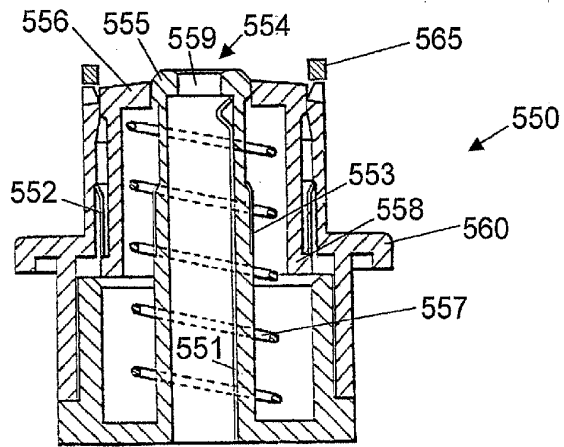

Fig. 15

SUBSTITUTE SHEET (RULE 26)

14/17

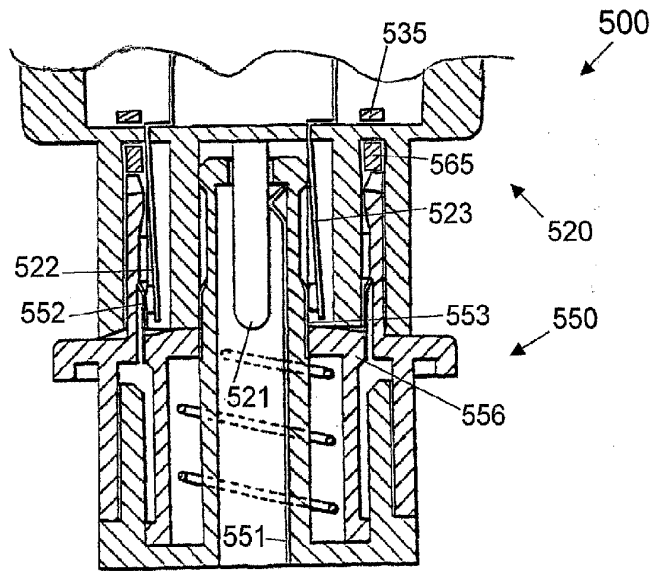
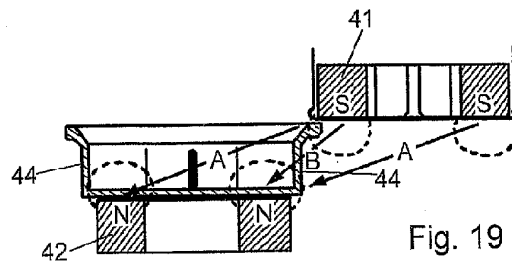
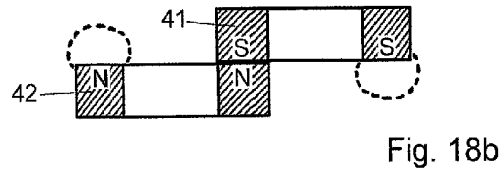
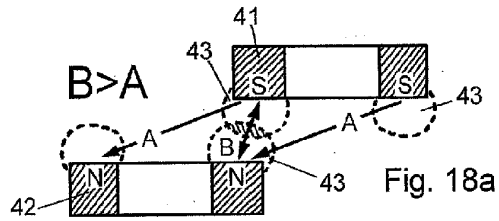
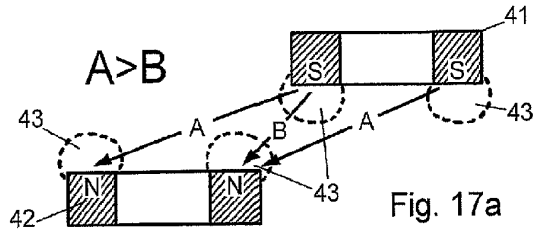

Fig. 16

SUBSTITUTE SHEET (RULE 26)

15/17



SUBSTITUTE SHEET (RULE 26)

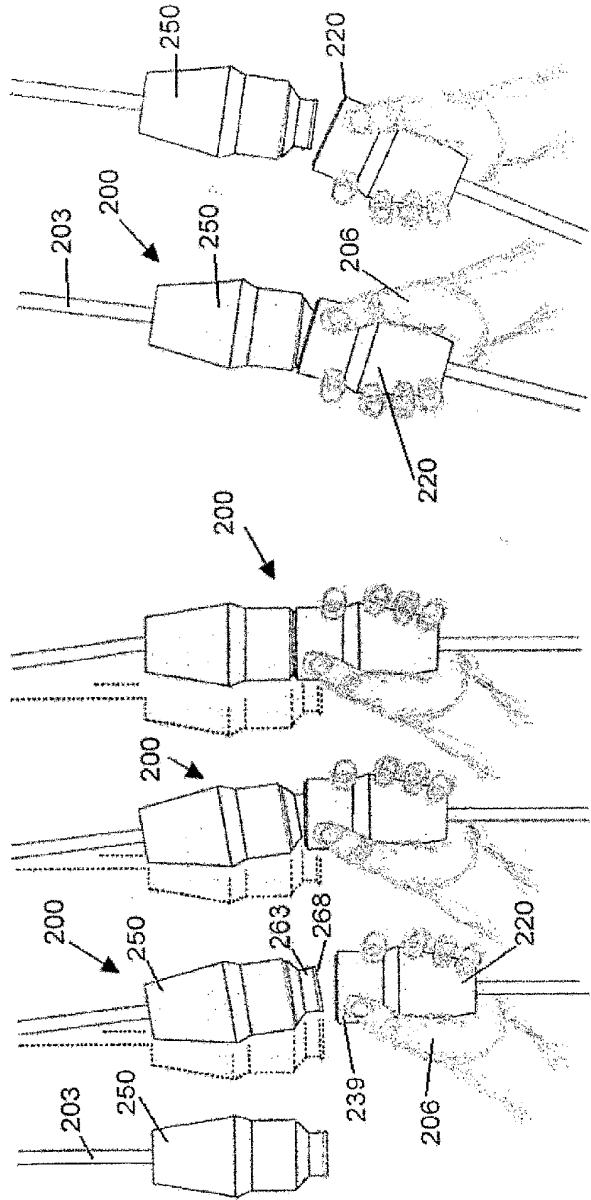

Fig. 20a Fig. 20b Fig. 20c Fig. 20d Fig. 20e Fig. 20f

SUBSTITUTE SHEET (RULE 26)

17/17

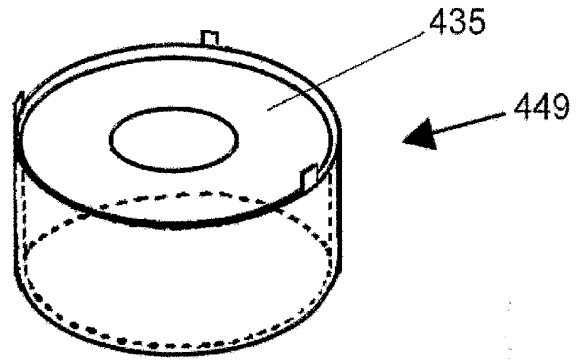

Fig. 21

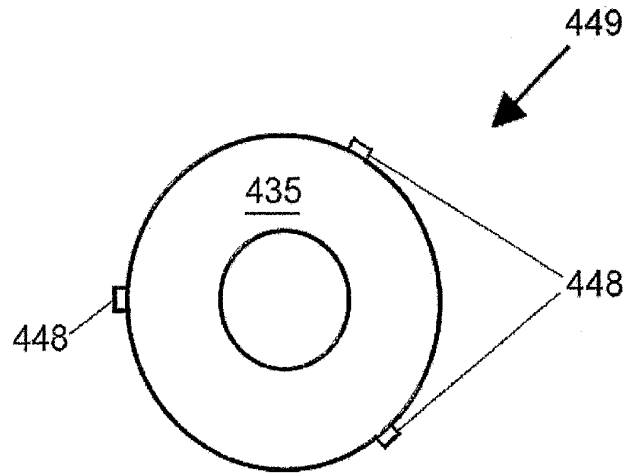

Fig. 22

SUBSTITUTE SHEET (RULE 26)