

March 6, 1956

E. J. PALMER

2,736,954

DEVICE FOR PULLING COUPLINGS, BEARINGS, AND WHEELS

Filed Nov. 18, 1952

Fig. 1

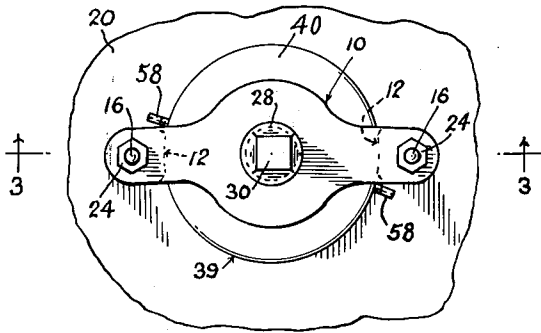

Fig. 3.

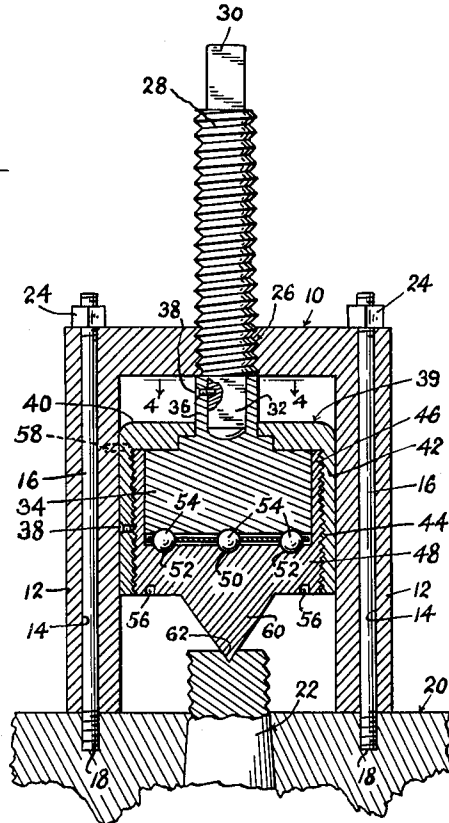

Fig. 2.

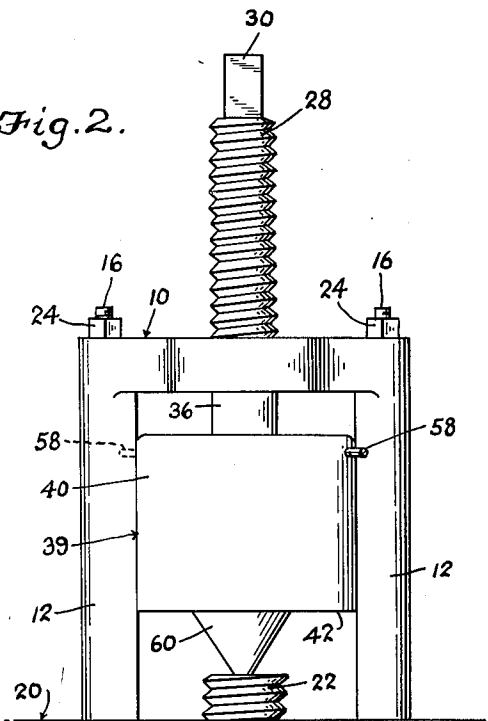

Fig. 5.

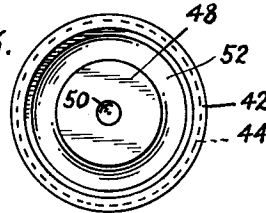

Fig. 4.

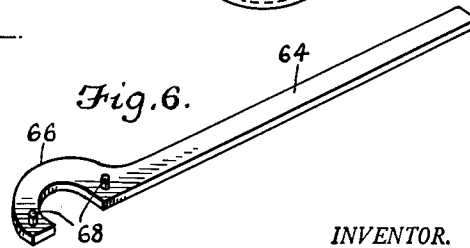
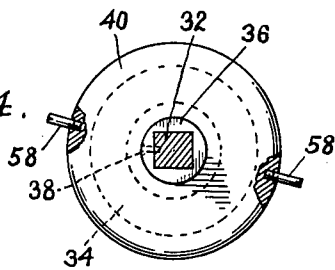

Fig. 6.

INVENTOR.
Ernest J. Palmer
BY

Mc Morrow, Berman & Davidson
Attorneys.

1

2,736,954

DEVICE FOR PULLING COUPLINGS, BEARINGS, AND WHEELS

Ernest J. Palmer, Bayonne, N. J.

Application November 18, 1952, Serial No. 321,161

2 Claims. (Cl. 29—259)

This invention relates to a puller of the mechanical type, and more particularly, has reference to a puller adapted primarily to the pulling of couplings, bearings, and wheels from shafts on which they are mounted.

It is one important object of the present invention to provide an improved device of the type stated which will be so designed as not to damage in any way the shaft against which pressure is exerted during the pulling of a coupling, bearing, or wheel.

Another object of importance is to provide a device as described which will be so formed as to pull couplings, bearings, or wheels varying in size from one another.

Yet another object is to provide a device of the type stated which will include a pressure exerting means engageable with the center of a shaft, said means being so formed as to automatically move into coaxial alignment with the shaft, thus to prevent damage to the shaft center.

Still another object of importance is to provide a device of the type stated which will be of simple construction, but which will nevertheless be ruggedly formed and so designed as to be usable over an indefinite period of time while requiring a minimum of repairs.

Still another object of importance is to provide a device of the type stated which, when applied to the article to be pulled, will be securely held in place upon said article, so as not to slip from its proper position while the article is being pulled.

Yet another object is to provide a device for pulling couplings, bearings, or wheels from shafts, which device will have a pressure block provided therein, the pressure block being rotatably mounted on ball bearings, thus to reduce friction to a minimum during the operation of the pulling mechanism.

Still another object is to provide a pulling device that will be operable with ease and speed.

Other objects will appear from the following description, the claims appended thereto, and from the annexed drawing, in which like reference characters designate like parts throughout the several views, and wherein:

Figure 1 is a top plan view of a puller formed in accordance with the present invention as it appears when in use, a wheel to be pulled being illustrated fragmentarily and in top plan;

Figure 2 is a side elevational view;

Figure 3 is a longitudinal sectional view taken substantially on line 3—3 of Figure 1;

Figure 4 is a transverse sectional view taken on line 4—4 of Figure 3;

Figure 5 is a plan view of a portion of the pressure block support member; and

Figure 6 is a perspective view of a wrench used in assembling and disassembling the pulling device.

Referring to the drawings in detail, the reference numeral 10 has been applied generally to a yoke constituting a component part of the invention.

The yoke 10 is of inverted U shape, and is integrally or otherwise rigidly formed to include a pair of spaced,

2

vertically disposed legs 12, fixedly connected at their upper ends by a horizontally disposed yoke.

Formed in the respective legs 12 are longitudinal bores 14, said bores opening at one end upon the upper surface of the bight of the yoke, and opening at their other ends upon the lower ends of the legs 12. Bolts 16 are removably positioned through the bores 14, and are threaded at their lower ends for engagement in recesses 18 provided in a wheel 20 to be pulled. The recesses 18, of course, are threaded complementarily to the threaded lower ends of the bolts 16.

The upper ends of the bolts 16 are also threaded, and project above the top surface of the bight of the yoke, to receive nuts 24.

By reason of the construction so far illustrated and described, it is seen that the yoke 10 is adapted to be fixedly attached to the gear or wheel 20 to be pulled, so as to remain stationary during the pulling operation.

Formed in the bight of the yoke, at a location equidistant from both legs 12, is a threaded opening 25, receiving the complementarily threaded shank 28 of a stud having a reduced head 30 at its upper end, and a reduced lower end portion 32. The head 30 and end portion 32 are of non-circular cross sectional configuration, and in the illustrated example, these parts of the stud are square in cross section. However, other non-circular cross sectional shapes can be used if desired.

A pressure block has been designated by the reference numeral 34, and is of solid, cylindrical formation, said pressure block having at its upper end an axial, upwardly extended neck 36 recessed to receive the end portion 32 of the stud. The recess of the neck 36 is shaped cross sectionally to complement the cross sectional shape of the end portion 32 of the stud, and after the stud has been inserted in the recessed neck 36, a set screw 38 is threaded into the portion 32 through the side wall of the neck, to prevent accidental separation of the stud and pressure block 34.

From the construction illustrated and described, it is seen that the yoke 10 may be secured to a wheel 20 to be pulled; and will remain stationary during the pulling operation. The stud 28 and pressure block 34, however, are jointly rotatable within and relative to the yoke, and when rotated, will be shifted longitudinally of the yoke, due to the threaded engagement between the stud and the opening 26 of the yoke.

A pressure block support member is also utilized in the invention, said member being designated generally by the reference numeral 39. The pressure block support member 39, in this connection, is formed as a pair of opposed cups. One of the cups has been designated by the reference numeral 40, said cup being formed as a disc-like member having a center opening through which the neck 36 of the pressure block extends. Integral with the peripheral portion of the disc of the cup 40 is a depending, cylindrical skirt 42, having internal threads 44 engageable with external threads provided upon the upstanding, cylindrical side wall 46 of a second cup 48.

The cups 40, 48 cooperate to define a pressure block support member having a hollow cavity in which the pressure block 34 is rotatably mounted.

A ball bearing is interposed between the rotatable pressure block 34 and its associated pressure block support member, and to this end, a center recess 50 is provided in the bottom of the cup 48, said recess 50 being concentric with and being surrounded by an annular recess 52.

Anti-friction elements 54 are disposed in the recesses 50, 52, the underside of the pressure block 34 having complementary recesses, thereby to provide a ball bearing that will assure rotation of the pressure block 34 within the pressure block support member, with a minimum of friction.

In the underside of the pressure block support member, there is provided a pair of diametrically opposite indentations 56, for a purpose to be made presently apparent.

Threadedly engaged in opposite sides of the cup 48 are screws 58 (Figure 4), said screws being disposed diametrically opposite one another and projecting outwardly of the cup 40.

The screws 58 are adapted to provide a means whereby rotation of the pressure block support member 39 relative to the yoke 10 is prevented. In other words, when the stud 28 is rotated by a suitable wrench or similar tool, the pressure block 34 will be rotated with the stud. Any tendency on the part of the pressure block support member to rotate with the pressure block 34 is precluded by engagement of the screws 58 against the respective legs 12 (see Figure 1).

Integrally formed upon the underside of the cup 48 is a depending, conical point 60, said point being engageable in a complementarily shaped recess 62 formed in the end of the shaft 22 on which the wheel 20 is mounted.

It will be apparent from the construction illustrated and described that on rotation of the stud 28, the pressure block support member and its associated pressure block 34 will be shifted longitudinally of the yoke 10, against the shaft 22. As a result, pressure will be exerted downwardly against the shaft 22, and this pressure will be translated into upward pull upon the wheel 20, said upward pull being transmitted through the yoke 10.

As a result, the wheel will be pulled from the shaft 22, in a minimum time and with little difficulty.

It is considered to be an important characteristic of the invention that the device is so formed as to prevent damage to the shaft 22, the point 60 automatically centering itself in the shaft center 62. Of course, there are other advantages, notably the simple construction of the device and the ease of operation of the same, and it is also thought to be of importance that the device can be used for pulling any of various articles, such as couplings, bearings, gears, and wheels.

In Figure 6, there is shown a wrench specially designed for use in assembling the various parts of the device. As will be noted, the wrench includes a handle or shank 64, integral at one end with an arcuate head 66. At opposite ends of the arcuate head 66 there are provided upstanding lugs 68.

In assembling the device, constituting the present invention, the lugs 68 can be entered into the diametrically opposite recesses 56, for the purpose of rotating the cup 48 relative to the cup 40, thereby to assemble said cups about the pressure block 34.

It will be understood that the cup or center 48, and the pressure block 34 would both be made of a hardened steel, and the stud 28 would be made of heat-treated steel, to avoid damage to the puller when in use and therefore lengthen the useful life thereof.

It will be further understood that if desired, a steel extension rod of circular cross section could be used, to extend the point 60 of cup or center 48. Such a rod would have a conical recess at one end receiving the point, and would have a point at the other end extendable into the recess 62 of the shaft 22.

It is believed apparent that the invention is not necessarily confined to the specific use or uses thereof described above, since it may be utilized for any purpose to which it may be suited. Nor is the invention to be necessarily limited to the specific construction illustrated and described, since such construction is only intended to be

illustrative of the principles of operation and the means presently devised to carry out said principles, it being considered that the invention comprehends any minor change in construction that may be permitted within the scope of the appended claims.

What is claimed is:

1. In a puller for wheels and the like, a U-shaped yoke having a bight portion and legs, said legs terminating in free ends for engaging a wheel or the like, said bight portion having a threaded opening therethrough, a threaded stud threaded through said opening, an outer cup having a sidewall slidably and non-rotatably engaged with and positioned between said legs, said outer cup having an endwall at the end thereof adjacent to said bight portion and an open end remote from said bight portion, said sidewall being internally threaded, said endwall being provided with a central opening, an inner cup within said outer cup, said inner cup having an open end facing said bight portion and an endwall remote from said bight portion, said inner cup having an externally threaded sidewall threadably engaging the sidewall of the outer cup, the side of the endwall of the inner cup remote from said bight portion having a central element for engaging a member from which a wheel is to be pulled, a cylindrical block rotatably confined in said inner cup, said block having a neck extending through the central opening in the outer cup endwall, means non-rotatably connecting said neck and said stud together, and anti-friction bearing means operatively interposed between the endwall of the inner cup and the end of said block remote from said neck.

2. In a puller for wheels and the like, a U-shaped yoke having a bight portion and legs, said legs terminating in free ends for engaging a wheel or the like, said bight portion having a threaded opening therethrough, a threaded stud threaded through said opening, an outer cup having a sidewall slidably and non-rotatably engaged with and positioned between said legs, said outer cup having an endwall at the end thereof adjacent to said bight portion and an open end remote from said bight portion, said sidewall being internally threaded, said endwall being provided with a central opening, an inner cup within said outer cup, said inner cup having an open end facing said bight portion and an endwall remote from said bight portion, said inner cup having an externally threaded sidewall threadably engaging the sidewall of the outer cup, the side of the endwall of the inner cup remote from said bight portion having a central element for engaging a member from which a wheel is to be pulled, a cylindrical block rotatably confined in said inner cup, said block having a neck extending through the central opening in the outer cup endwall, means non-rotatably connecting said neck and said stud together, and anti-friction bearing means operatively interposed between the endwall of the inner cup and the end of said block remote from said neck, said block having an end rotatably engaged with the endwall of the outer cup and a peripheral surface rotatably engaged with the sidewall of the inner cup.

References Cited in the file of this patent

UNITED STATES PATENTS

611,832	Coughlan	Oct. 4, 1898
1,268,541	Benedict	June 4, 1918
1,354,390	Gilmore	Sept. 28, 1920
1,597,909	Livesay	Aug. 31, 1926
2,385,000	Hoke	Sept. 18, 1945