

United States Patent

[11] 3,589,070

[72] Inventor **Carl Arthur Hansen**
Bethel, Conn.
[21] Appl. No. **25,504**
[22] Filed **Apr. 3, 1970**
[45] Patented **June 29, 1971**
[73] Assignee **Ray Proof Corporation**
Norwalk, Conn.

FOREIGN PATENTS

909,009 10/1962 Great Britain..... 49/483
968,968 9/1964 Great Britain..... 49/483

Primary Examiner—David J. Williamowsky
Assistant Examiner—Philip C. Kannan
Attorney—Pennie, Edmonds, Morton, Taylor and Adams

[54] **RADIATION-RESISTANT JOINT BETWEEN DOOR AND FRAME**
4 Claims, 4 Drawing Figs.

[52] U.S. Cl..... 49/483,
49/488, 174/35 MS
[51] Int. Cl..... E06b 7/22
[50] Field of Search..... 49/483,
488, 475; 174/35 GC, 35 MS; 339/217 S

[56] **References Cited**
UNITED STATES PATENTS

3,296,356 1/1967 McAdams 49/483 X
3,437,735 4/1969 Schaller, Jr. 174/35 MS

ABSTRACT: A device for use with a radiation-resistant enclosure in forming a radiation-resistant joint between the edges of a door for the enclosure and the door frame, the device including cooperating parts on the edges of the door and frame respectively, one of the parts having a lateral slot at right angles to the door when it is closed and with parallel walls extending lengthwise of said edges and with spaced inwardly engaged bowed resilient metallic fingers on the walls of said slot. The other of said parts has a member which enters between the bowed fingers for establishing both mechanical and electrical connection between the parts when the door is closed. The fingers are specially shaped and specially mounted so that they cannot be accidentally removed but at the same time greatly facilitate assembly and repair in case of breakage.

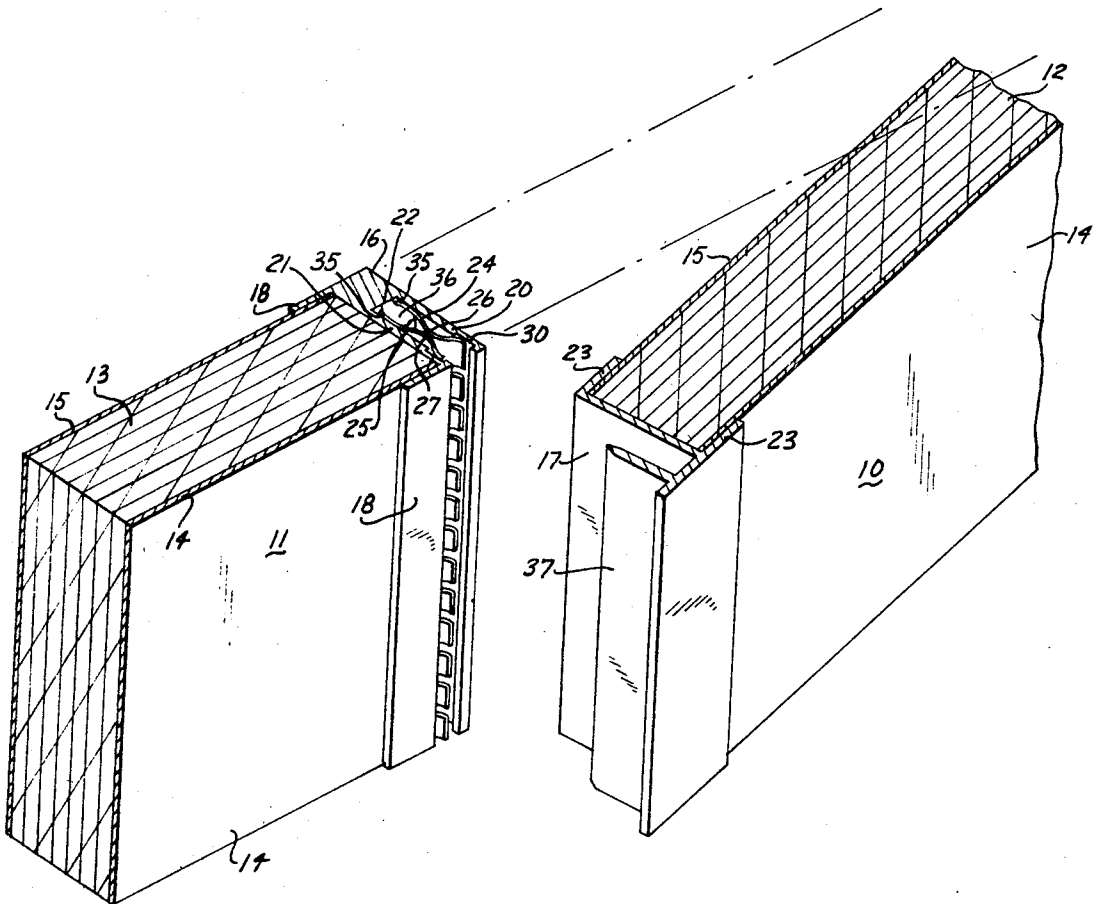

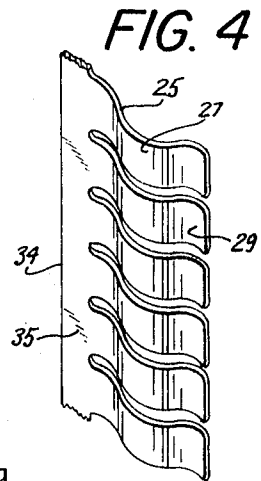
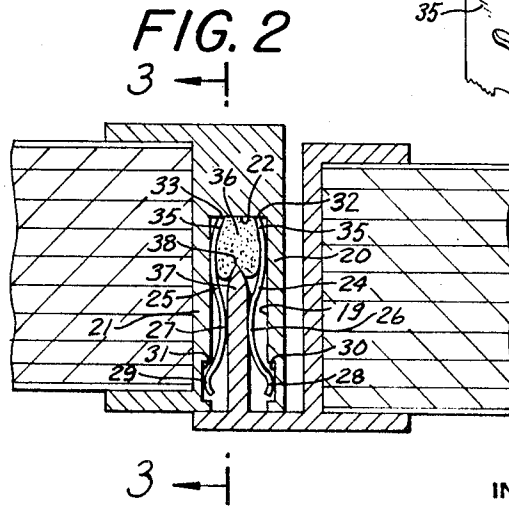
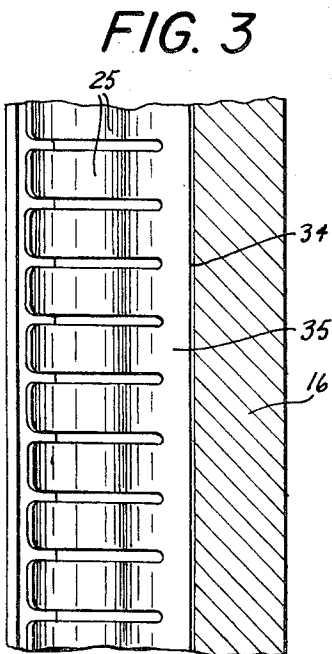
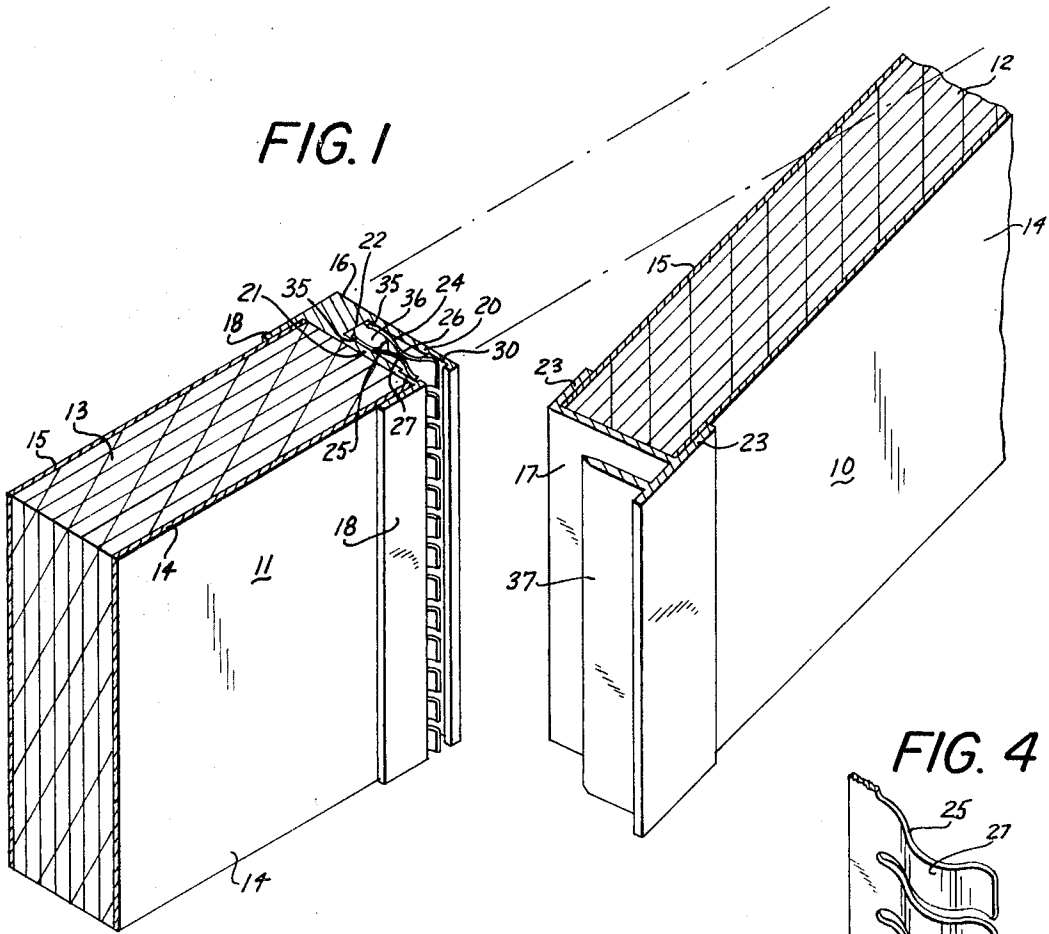

INVENTOR
CARL ARTHUR HANSEN
BY
Pennie, Edmonds, Minton, Taylor & Adams
ATTORNEYS

RADIATION-RESISTANT JOINT BETWEEN DOOR AND FRAME

BACKGROUND OF THE INVENTION

1. Field of the Invention

Relates to the improvement and construction of radiation-shielded enclosures of the type designed to have an interior that may be relatively isolated from radio interference and other radiation. The invention is particularly directed to the construction of door joints for such enclosures for the purpose of increasing the resistance to radiation penetration through the joints between the edges of a door and its frame.

2. Description of the Prior Art

The Tibbs et al. British Pat. No. 909,009 discloses a channel on one enclosure or screening member and a lip on the cooperating member arranged to fit into this channel when the door is closed. A contact spring, or springs, "arranged within the channel" make contact with the opposite sides of the lip which is on the lid or door. The arrangement of these contact springs is objectionable because in some instances they may become dislodged from their positions within the channel, and if any of these contact springs should be missing the interference with radiation would be seriously impaired.

SUMMARY OF THE INVENTION

The radiation-resistant joint of the present invention comprises first and second cooperating members, one being fixed permanently to the edge of the door and the other similarly attached to the edge of the door frame. The first member includes a slot having bottom and sidewalls, the slot being rectangular in cross section and lying in a plane substantially at right angles to the plane of the door when it is closed, the mouth or opening of the slot facing outwardly from the chamber or enclosure with which the door is associated. This rectangular slot extends throughout the length of the edges of the door and its frame. The walls of this slot are provided with shallow grooves which face one another near the opening of the slot. Arranged on the opposite walls of the slot are resilient contact fingers the central portions of which are bowed into contact with each other. Such contact fingers are prevented from moving laterally out of the slot by the engagement of the ends of the fingers within the shallow grooves.

Fixed on the second of said cooperating members is a rigid metallic plate the width of which is comparable to the depth of the slot referred to and the length of which corresponds with the length of the slot. When the door is closed the forward vertical edge of this member is forced between the contacting bowed central portions of the resilient contact fingers, and forces them apart, making good electrical and mechanical contact with both sets of fingers and causing the end portions of the fingers to shift on the surfaces of the walls of the slot thereby renewing and maintaining their electrical contact with these walls. In order to provide a sound and air seal as well a strip of flexible resilient material such as a foam plastic is inserted between the inner end portions of the contact fingers associated with the opposite walls of the slot. This sealing member extends throughout the length of the slot and its outer surface is engaged by the inner edge of the cooperating member on the door when the door is closed.

The spring fingers are advantageously formed on a comblike member extending lengthwise of the slot and serving to interconnect the bowed spring fingers at their rear ends.

BRIEF DESCRIPTION OF THE DRAWING

FIG. 1 is an isometric view of a portion of a door for a radiation-resistant enclosure and a portion of the frame of the enclosure against which the front edge of the door closes, the door being shown in slightly open position.

FIG. 2 is a horizontal sectional view of the two edge portions of the door and frame with the door in fully closed position.

FIG. 3 is a vertical section taken on line 3-3 of FIG. 2, and

FIG. 4 is an isometric view of a fragmentary portion of one of the comblike members.

DESCRIPTION OF THE PREFERRED EMBODIMENT

In FIG. 1 of the drawings a door 10 is arranged to swing about hinges (not shown) located at the right of the portion of the door illustrated. This door cooperates with a frame 11 which may be a portion of the wall of the enclosure in which the door is placed. A radiation-proof enclosure and a door for entering and leaving the enclosure are disclosed in applicant's copending application Ser. No. 888,091 filed Dec. 24, 1969 entitled "Automatic Door Operating Mechanism for Radiation-Proof Enclosures."

As shown in FIG. 1 of the present application both door 10 and frame or wall 11 are composed of wood laminations 12 and 13 respectively and these are sheathed on their opposite sides or faces by metallic sheets 14 and 15. Joint member 16 of the present invention is mounted on the front vertical edge of door frame 11 and the cooperating joint member 17 is mounted on the corresponding edge of door 10.

Joint member 16 has a pair of flanges 18 which are mounted in fixed relation to door frame 11 as for example by being soldered or welded to the frame side sheets 14 and 15. Joint member 16 has a vertical rectangular slot 19 formed by outer and inner parallel walls 20 and 21 which project forwardly from the bottom or rear wall 22. The mouth or opening of slot 19 faces the outside of the enclosure, the enclosure being disposed at the left of door 10 and frame 11 as shown in FIG. 1.

Cooperating member 17 of the radiation-resistant joint is secured to the front vertical edge of door 10 in a manner similar to that above described. In this case flanges 23 are fixed, as for example, by soldering or welding, to the side sheets 14 and 15 of the door.

The radiation-resistant joint of the invention includes outer and inner sets of opposed resilient contact fingers 24 and 25 desirably made of Beryllium copper. Each of the fingers 24 has a bowed central section 26 and fingers 25 have similarly bowed central sections 27. The tip portions 28 of fingers 24 and the tip portions 29 of fingers 25 are formed as shown in FIGS. 2 and 4. The respective fingers 24 and 25 are held in position in the rectangular slot 19 by their tip portions 28 and 29 which are received in shallow grooves 30 and 31 arranged in the walls 20 and 21 of slot 19 close to the mouth of the slot and by the engagement of the rear ends 32 and 33 with the back wall 22 of slot 19.

These bowed fingers need no other positioning in slot 19 except to maintain them in parallel spaced relation. This may be done in any convenient way, but as shown it is accomplished by forming the bowed contact fingers 24 and 25 as the teeth of two comblike members, one extending along each side of slot 19. A section of the comblike member 34 for the contact fingers 25 is shown in FIG. 4. The contact fingers project outwardly from a common strip of metal 35 which would correspond to the back of a comb. The comblike member for the contact fingers 24 is like member 34 although not shown in the drawings.

Between the inner portions or strips of metal 35 of the two comb members a sound and air seal 36 may be placed. This is composed of a foam plastic such as urethane having a covering of vinyl.

When door 10 is moved into closed position a vertical rigid plate member 37 which is mounted on joint member 17 enters between the bowed portions 26 and 27 of the contact fingers which, before the door was closed, are in contact with one another as shown in FIG. 1. The entrance of member 37 forces the bowed opposing portions of the contact fingers 24 and 25 apart and to the positions shown in FIG. 2. This movement of the bowed portions 26 and 27 causes a rocking movement of both the tip portions 28 and 29 and the back strips 35.

In FIG. 1 these portions 35 are shown in flat position against the inner surfaces of the walls 20 and 21 of slot 19 adjacent the back wall 22. In FIG. 2 the rocking movement referred to

has caused portions 35 to swing inwardly and slightly away from the surface of the slot. This rocking of the tips 28 and 29 and the rear portions 35 produces a sliding movement of the parts on the surfaces of grooves 30, 31 and the rear portions of walls 20 and 21. These motions are important as they maintain good electrical contacts, such being necessary in order to provide a radiation-proof joint.

In FIG. 2 it is shown that the inner edge of plate 37, which is desirably pointed, has created a lengthwise depression 38 in the foam plastic seal 36. This produces an air seal throughout the length of the edges of the door and frame. It also imparts to the joint greater sound-proofness.

The two comblike members 34 are continuous and extend throughout the length of slot 19, but should any of the contact fingers become damaged or broken it is a simple matter to remove a section or sections of either of the comblike members and insert new sections.

It will be understood that the radiation-resistant joint which has been described is applied to the top and bottom edges of the door and frame and to the rear edges thereof, as well as to the front edges shown in the drawings.

It is desirable to renew the two electrical contacts between the parts of the radiation-resistant joint from time to time. The construction described permits of the application of a fluid which washes down and flows away the oxydized materials which may have collected during the previous weeks or months of use of the radiation-resistant joint.

The comblike members are not soldered or otherwise attached to the walls of slot 19 but are held in place by the engagement of the tips 28 and 29 of the contact fingers in the shallow grooves 30 and 31, and the engagement of back strips 35 with the back wall of this slot.

I claim:

1. A closure for use in forming a radiation-resistant joint between the edges of a door and its frame, the closure for one edge of the door and the corresponding edge of the frame comprising:

- a. first and second members, one of said members being fixed to the door edge and the other member fixed to the frame edge.

b. the first member having a lengthwise slot with back and sidewalls, said slot being transverse to the plane of the door in the closed position, the walls of said slot being parallel and having grooves near their outer edges extending opposite each other throughout the length of said slot.

c. opposed resilient contact fingers disposed in spaced approximately parallel relation on said respective walls throughout the length of said slot, the central portions of said opposed fingers being bowed into contact with each other, said fingers being held in position laterally by the engagement of their inner ends with the bottom of said slot and the engagement of their outer ends in said grooves, and

d. said second member having mounted thereon a plate extending throughout the closure edge of the door and frame, said plate being insertable within said slot and engaging the centrally bowed portions of said fingers so as to force them apart in good electrical contact therewith.

2. A closure for use in a radiation-resistant joint between the edges of a door and its frame according to claim 1 in which the contact fingers along each wall of the slot project in slightly spaced relation from a common supporting portion extending along one edge of said row of fingers forming a comblike member.

3. A closure for use in forming a radiation-resistant joint between the edges of a door and its frame according to claim 2 in which a pair of said comblike members is arranged with their bowed fingers opposing and in contact with one another and positioned laterally within said slot and with the common edge portions of the comblike members resting in unattached relation to the back wall of the slot and the adjacent portions of the two sidewalls.

4. A closure for use in forming a radiation-resistant joint between the edges of a door and its frame according to claim 3 wherein a sealing member of soft resilient material is disposed adjacent the back wall of said slot and in contact with the surfaces of the opposing comb members, the front surface of the sealing member being depressed by the edge of said plate when the door is closed.

45

50

55

60

65

70

75