

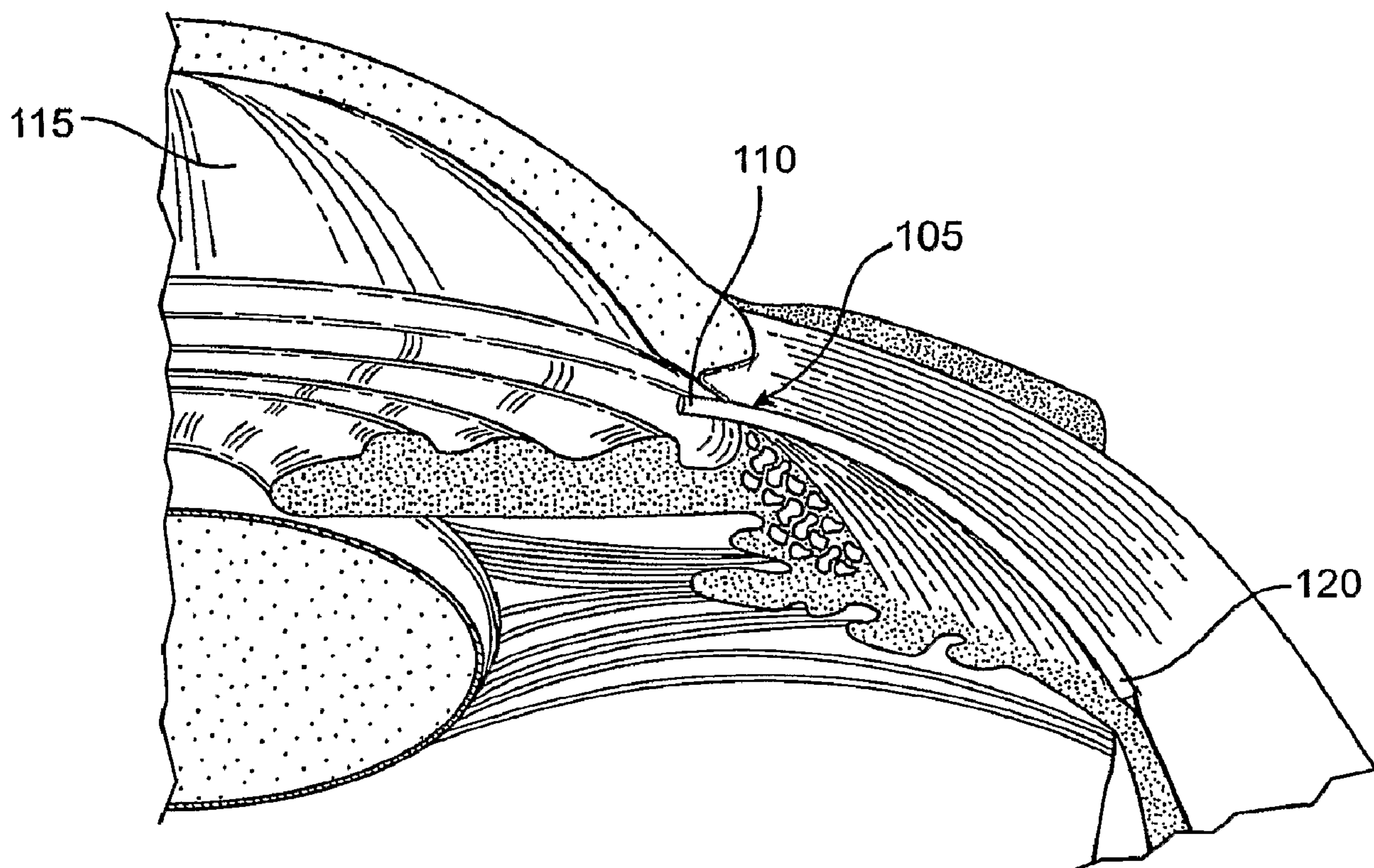

(86) Date de dépôt PCT/PCT Filing Date: 2006/12/22
 (87) Date publication PCT/PCT Publication Date: 2007/08/02
 (85) Entrée phase nationale/National Entry: 2008/07/17
 (86) N° demande PCT/PCT Application No.: US 2006/049234
 (87) N° publication PCT/PCT Publication No.: 2007/087061
 (30) Priorités/Priorities: 2006/01/17 (US60/759,835);
 2006/03/17 (US60/783,632); 2006/09/01 (US60/824,396)

(51) Cl.Int./Int.Cl. *A61M 5/00* (2006.01)
 (71) Demandeur/Applicant:
 TRANSCEND MEDICAL, INC., US
 (72) Inventeurs/Inventors:
 DE JUAN, EUGENE, US;
 BOYD, STEPHEN, US;
 DEEM, MARK E., US;
 GIFFORD, HANSON S., III, US;
 ROSENMAN, DAN, US
 (74) Agent: MBM INTELLECTUAL PROPERTY LAW LLP

(54) Titre : DISPOSITIF DE TRAITEMENT DE GLAUCOME
 (54) Title: GLAUCOMA TREATMENT DEVICE



(57) Abrégé/Abstract:

Methods and devices are adapted for implanting into the eye. An incision is formed in the cornea of the eye and a shunt is inserted through the incision into the anterior chamber of the eye. The shunt includes a fluid passageway. The shunt is passed along a pathway from the anterior chamber through the scleral spur of the eye into the suprachoroidal space and positioned in a first position such that a first portion of the fluid passageway communicates with the anterior chamber and a second portion of the fluid passageway communicates with the suprachoroidal space to provide a fluid passageway between the suprachoroidal space and the anterior chamber.

(12) INTERNATIONAL APPLICATION PUBLISHED UNDER THE PATENT COOPERATION TREATY (PCT)

(19) World Intellectual Property Organization
International Bureau(43) International Publication Date
2 August 2007 (02.08.2007)

PCT

(10) International Publication Number
WO 2007/087061 A3

(51) International Patent Classification:

A61M 5/00 (2006.01)

(21) International Application Number:

PCT/US2006/049234

(22) International Filing Date:

22 December 2006 (22.12.2006)

(25) Filing Language:

English

(26) Publication Language:

English

(30) Priority Data:

60/759,835 17 January 2006 (17.01.2006) US

60/783,632 17 March 2006 (17.03.2006) US

60/824,396 1 September 2006 (01.09.2006) US

(71) Applicant (for all designated States except US): **TRANSCEND MEDICAL, INC.** [US/US]; 199 Jefferson Drive, Menlo Park, CA 94025 (US).

(72) Inventors; and

(75) Inventors/Applicants (for US only): **DE JUAN, Eugene** [US/US]; 276 Edgewood Avenue, San Francisco, CA 94117 (US). **BOYD, Stephen** [US/US]; 23809 Hayes Avenue, Murrieta, CA 92562 (US). **DEEM, Mark, E.** [US/US]; 685 Sierra Avenue, Mountain View, CA 94041(US). **GIFFORD, Hanson, S., III** [US/US]; 3180 Woodside Road, Woodside, CA 94062 (US). **ROSENMAN, Dan** [US/US]; 205 Caselli Avenue, San Francisco, CA 94114 (US).(74) Agents: **HERNANDEZ, Fred, C.** et al.; FISH & RICHARDSON P.C., 12390 El Camino Real, San Diego, CA 92130 (US).

(81) Designated States (unless otherwise indicated, for every kind of national protection available): AE, AG, AL, AM, AT, AU, AZ, BA, BB, BG, BR, BW, BY, BZ, CA, CH, CN, CO, CR, CU, CZ, DE, DK, DM, DZ, EC, EE, EG, ES, FI, GB, GD, GE, GH, GM, GT, HN, HR, HU, ID, IL, IN, IS, JP, KE, KG, KM, KN, KP, KR, KZ, LA, LC, LK, LR, LS, LT, LU, LV, LY, MA, MD, MG, MK, MN, MW, MX, MY, MZ, NA, NG, NI, NO, NZ, OM, PG, PH, PL, PT, RO, RS, RU, SC, SD, SE, SG, SK, SL, SM, SV, SY, TJ, TM, TN, TR, TT, TZ, UA, UG, US, UZ, VC, VN, ZA, ZM, ZW.

(84) Designated States (unless otherwise indicated, for every kind of regional protection available): ARIPO (BW, GH, GM, KE, LS, MW, MZ, NA, SD, SL, SZ, TZ, UG, ZM, ZW), Eurasian (AM, AZ, BY, KG, KZ, MD, RU, TJ, TM), European (AT, BE, BG, CH, CY, CZ, DE, DK, EE, ES, FI,

[Continued on next page]

(54) Title: GLAUCOMA TREATMENT DEVICE

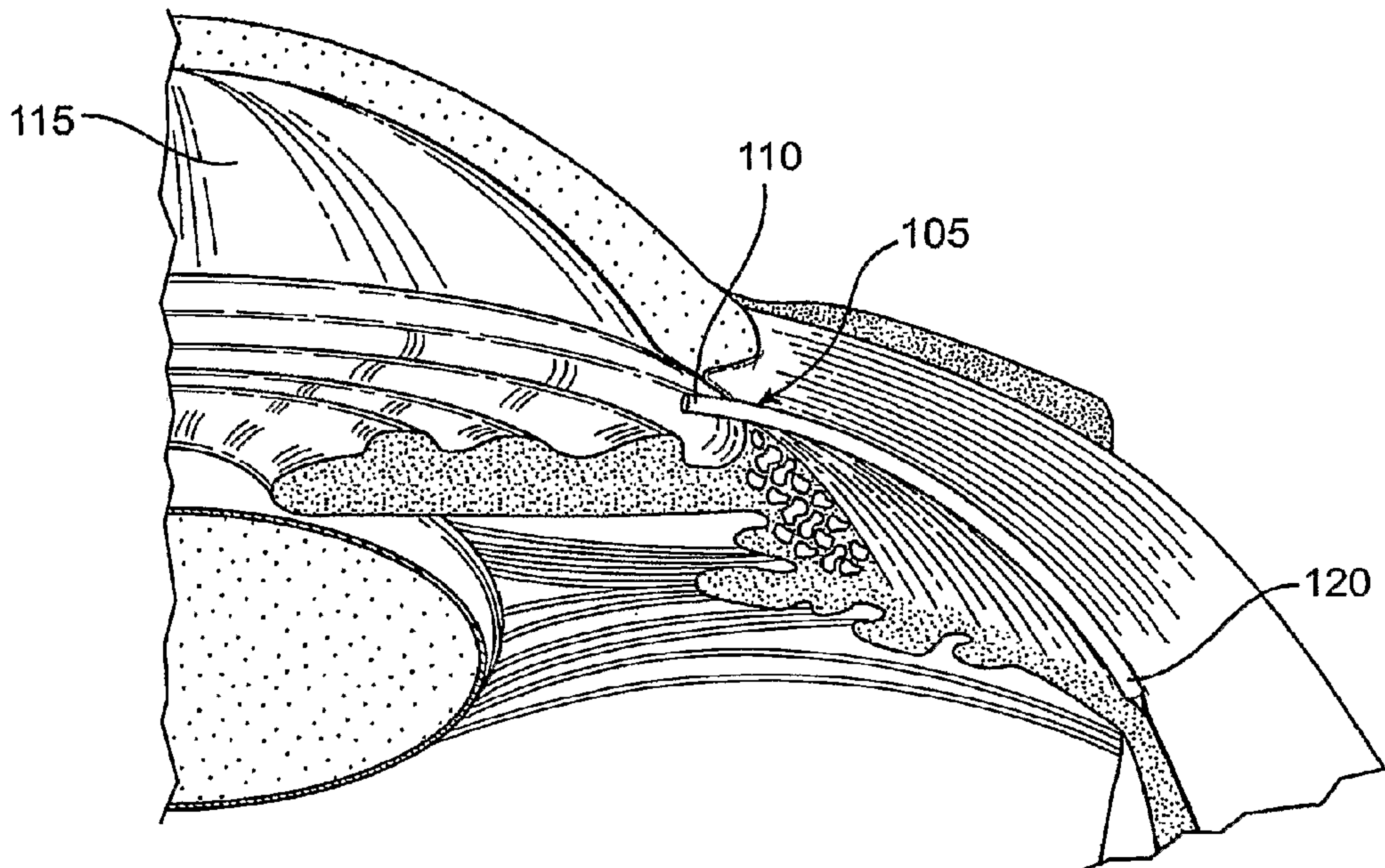

(57) Abstract: Methods and devices are adapted for implanting into the eye. An incision is formed in the cornea of the eye and a shunt is inserted through the incision into the anterior chamber of the eye. The shunt includes a fluid passageway. The shunt is passed along a pathway from the anterior chamber through the scleral spur of the eye into the suprachoroidal space and positioned in a first position such that a first portion of the fluid passageway communicates with the anterior chamber and a second portion of the fluid passageway communicates with the suprachoroidal space to provide a fluid passageway between the suprachoroidal space and the anterior chamber.

WO 2007/087061 A3

WO 2007/087061 A3



FR, GB, GR, HU, IE, IS, IT, LT, LU, LV, MC, NL, PL, PT,
RO, SE, SI, SK, TR), OAPI (BF, BJ, CF, CG, CI, CM, GA,
GN, GQ, GW, ML, MR, NE, SN, TD, TG).

For two-letter codes and other abbreviations, refer to the "Guidance Notes on Codes and Abbreviations" appearing at the beginning of each regular issue of the PCT Gazette.

Published:

- *with international search report*
- *before the expiration of the time limit for amending the claims and to be republished in the event of receipt of amendments*

(88) Date of publication of the international search report:

13 December 2007

GLAUCOMA TREATMENT DEVICE

Related Applications

Benefit of priority under 35 U.S.C. § 119(e) is claimed to U.S. Provisional Application Serial No 60/759,835, filed January 17, 2006, to Eugene de Juan, Jr., Stephen Boyd, Mark E. Deem, Hanson S. Gifford III and Angela Macfarlane, entitled "GLAUCOMA TREATMENT DEVICE;" to U.S. Provisional Application Serial No 60/783,632, filed March 17, 2006, to Eugene de Juan, Jr., Stephen Boyd, Mark E. Deem, Hanson S. Gifford III and Angela Macfarlane, entitled "GLAUCOMA TREATMENT DEVICE"; and to U.S. Provisional Application Serial No. 60/824,396, filed September 1, 2006, to Eugene de Juan, Jr., Stephen Boyd, Mark E. Deem, and Hanson S. Gifford III, entitled "GLAUCOMA TREATMENT DEVICE."

This application also is related to U.S. application No. (attorney docket no. 21800-002001) filed the same day herewith.

The subject matter of each of the above-noted provisional applications and international applications is incorporated by reference in its entirety by reference thereto.

BACKGROUND

This disclosure relates generally to methods and devices for use in treating glaucoma. The mechanisms that cause glaucoma are not completely known. It is known that glaucoma results in abnormally high pressure in the eye, which leads to optic nerve damage. Over time, the increased pressure can cause damage to the optic nerve, which can lead to blindness. Treatment strategies have focused on keeping the intraocular pressure down in order to preserve as much vision as possible over the remainder of the patient's life.

Past treatment has included the use of drugs that lower intraocular pressure through various mechanisms. The glaucoma drug market is an approximate two

billion dollar market. The large market is mostly due to the fact that there are not any effective surgical alternatives that are long lasting and complication-free. Unfortunately, drug treatments need much improvement, as they can cause adverse side effects and often fail to adequately control intraocular pressure. Moreover, patients are often lackadaisical in following proper drug treatment regimens, resulting in a lack of compliance and further symptom progression.

With respect to surgical procedures, one way to treat glaucoma is to implant a drainage device, or shunt, in the eye. The drainage device functions to drain aqueous humour from the anterior chamber and thereby reduce the intraocular pressure. The drainage device is typically implanted using an invasive surgical procedure. Pursuant to one such procedure, a flap is surgically formed in the sclera. The flap is folded back to form a small cavity and a shunt is inserted into the eye through the flap. Such a procedure can be quite traumatic as the implants are large and can result in various adverse events such as infections and scarring, leading to the need to re-operate.

The following references describe various devices and procedures for treating glaucoma: United States Patent 6,827,700 to Lynch, 6,666,841 to Bergheim, 6,508,779 to Suson, 6,544,208 to Ethier, 5,601,094 to Reiss, 6,102,045 to Nordquist, United States Patent Application 2002/0156413 to Williams, 2002/0143284 to Tu, 2003/0236483 to Ren, 2002/0193725 to Odrich, 2002/0165478 to Gharib, 2002/0133168 to Smedley, 2005/0107734, 2004/0260228 to Lynch, 2004/0102729 to Haffner, 2004/0015140 to Shields, 2004/0254521 to Simon, and 2004/0225250 to Yablonski. The aforementioned references are all incorporated herein by reference in their entireties.

Current devices and procedures for treating glaucoma have disadvantages and only moderate success rates. The procedures are very traumatic to the eye and also require highly accurate surgical skills, such as to properly place the drainage device in a proper location. In addition, the devices that drain fluid from the anterior chamber to a subconjunctival bleb beneath a scleral flap are prone to

infection, and can occlude and cease working. This can require re-operation to remove the device and place another one, or can result in further surgeries. In view of the foregoing, there is a need for improved devices and methods for the treatment of glaucoma.

5

SUMMARY

Disclosed are devices and methods for treatment of eye disease such as glaucoma. A shunt is placed in the eye wherein the shunt provides a fluid pathway for the flow or drainage of aqueous humour from the anterior chamber to the
10 suprachoroidal space. The shunt is implanted in the eye using a delivery system that uses a minimally invasive procedure, as described below. By guiding fluid directly into the supraciliary or suprachoroidal space rather than to the surface of the eye, complications commonly encountered with conventional glaucoma surgery should be avoided. Shunting aqueous fluid flow directly into the supraciliary or
15 suprachoroidal space should minimize scarring since the angle region is populated with a single line of non-proliferating trabecular cells. Shunting aqueous flow directly into the supraciliary or suprachoroidal space should minimize hypotony and also potentially eliminate complications such as endophthalmitis and leaks since an external filtering bleb is not the goal of surgery. The device described herein is
20 designed to enhance aqueous flow through the normal outflow system of the eye with minimal to no complications. Any of the procedures and device described herein can be performed in conjunction with other therapeutic procedures, such as laser iridotomy, laser iridoplasty, and goniosynechialysis (a cyclodialysis procedure).

In one aspect, there is disclosed a glaucoma treatment device comprising an
25 elongate member having a flow pathway, at least one inflow port communicating with the flow pathway, and an outflow port communicating with the flow pathway. The inflow port and outflow port are positioned such that the flow pathway provides a fluid pathway between an anterior chamber and a suprachoroidal space when the elongate member is implanted in the eye.

Among the methods provided herein, is a method of implanting an ocular device into the eye, comprising forming an incision in the cornea of the eye; inserting a shunt through the incision into the anterior chamber of the eye wherein the shunt includes a fluid passageway; passing the shunt along a pathway from the anterior chamber through the scleral spur of the eye into the suprachoroidal space; and positioning the shunt in a first position such that a first portion of the fluid passageway communicates with the anterior chamber and a second portion of the fluid passageway communicates with the suprachoroidal space to provide a fluid passageway between the suprachoroidal space and the anterior chamber.

10 In other embodiments, provided herein is a method of implanting an ocular device into the eye, comprising forming an incision in the cornea of the eye; inserting a shunt through the incision into the anterior chamber of the eye wherein at least a portion of the shunt can be opened to permit fluid flow along the shunt; passing the shunt along a pathway from the anterior chamber through the scleral spur of the eye into the suprachoroidal space; positioning the shunt in a first position such that a first portion of the shunt communicates with the anterior chamber and a second portion of the shunt communicates with the suprachoroidal space; and opening the shunt to permit fluid flow so that the shunt provides a fluid passageway between the suprachoroidal space and the anterior chamber.

20 In other embodiments, provided herein is a method of implanting an ocular device into the eye, comprising forming an incision in the cornea of the eye; mounting a shunt on a delivery device wherein at least a portion of the shunt or the delivery device has a curvature that matches a curvature of the eye; inserting the shunt through the incision into the anterior chamber of the eye wherein the shunt includes a fluid passageway; aiming the shunt relative to the suprachoroidal space such that the curvature of the shunt or the delivery device aligns with the curvature of the eye; and inserting at least a portion of the shunt into the suprachoroidal space to provide a fluid passageway between the suprachoroidal space and the anterior chamber.

In still further embodiments, provided herein is a method of implanting an ocular device into the eye, comprising forming an incision in the cornea of the eye; inserting a shunt through the incision into the anterior chamber of the eye wherein the shunt includes a fluid passageway; passing the shunt along a pathway from the anterior chamber through the scleral spur of the eye into the suprachoroidal space; and positioning the shunt in a first position such that a first portion of the fluid passageway communicates with the anterior chamber and a second portion of the fluid passageway communicates with the suprachoroidal space to provide a fluid passageway between the suprachoroidal space and the anterior chamber wherein the shunt is pre-shaped to position the first portion away from the iris.

In further embodiments, provided herein is a method of implanting an ocular device into the eye, comprising forming an incision in the sclera of the eye; inserting a shunt through the incision into the suprachoroidal space of the eye wherein the shunt includes a fluid passageway; passing the shunt along a pathway from the suprachoroidal space through the scleral spur of the eye into the anterior chamber; and positioning the shunt in a first position such that a first portion of the fluid passageway communicates with the anterior chamber and a second portion of the fluid passageway communicates with the suprachoroidal space to provide a fluid passageway between the suprachoroidal space and the anterior chamber.

Also provided herein, is a glaucoma treatment device, comprising an elongate member having a flow pathway, at least one inflow port communicating with the flow pathway, and an outflow port communicating with the flow pathway, wherein the elongate member is adapted to be positioned in the eye such that the inflow port communicates with the anterior chamber, the outflow port communicates with the suprachoroidal space, and at least a portion of the elongate member passes through the scleral spur to provide a fluid pathway between the anterior chamber and the suprachoroidal space when the elongate member is implanted in the eye.

In other embodiments, provided herein is a glaucoma treatment device, comprising an elongate member having a flow pathway, at least one inflow port communicating with the flow pathway, and an outflow port communicating with the flow pathway, wherein the elongate member is adapted to be positioned in the eye such that the inflow port communicates with the anterior chamber and the outflow port communicates with the suprachoroidal space, wherein at least a portion of the elongate member includes an enlarged bulbous region adapted to form a space within the suprachoroidal space for accumulation of fluid within the suprachoroidal space.

10 In another embodiment, provided herein is a glaucoma treatment device, comprising an elongate member having a flow pathway, at least one inflow port communicating with the flow pathway, and an outflow port communicating with the flow pathway, wherein the elongate member is adapted to be positioned in the eye such that the inflow port communicates with the anterior chamber and the outflow port communicates with the suprachoroidal space, the elongate member having a first region and a second region, wherein the second region is adapted to transition from a first shape to a second shape while the first regions remains unchanged.

15 In another embodiment, provided herein is a glaucoma treatment device, comprising a curved member sized to fit within an angle between the cornea and the iris of an eye; at least two legs extending outwardly from the curved member and shaped to extend into the suprachoroidal space, wherein at least one of the legs provides a fluid flow pathway into the suprachoroidal space.

20 In still further embodiments, provided herein is a glaucoma treatment system, comprising an elongate member having a flow pathway, at least one inflow port communicating with the flow pathway, and an outflow port communicating with the flow pathway, wherein the elongate member is adapted to be positioned in the eye such that the inflow port communicates with the anterior chamber and the outflow port communicates with the suprachoroidal space, wherein at least a portion of the elongate member includes an enlarged bulbous region adapted to form a space

within the suprachoroidal space for accumulation of fluid within the suprachoroidal space; and a delivery device having an elongate applier that removably attaches to the elongate member, the delivery device including an actuator that removes the elongate member from the applier.

5 Other features and advantages should be apparent from the following description of various embodiments, which illustrate, by way of example, the principles of the invention.

BRIEF DESCRIPTION OF THE DRAWINGS

10 Figure 1 is a cross-sectional, perspective view of a portion of the eye showing the anterior and posterior chambers of the eye.

Figure 2 is a cross-sectional view of a human eye.

Figure 3A shows a first embodiment of any eye shunt.

Figure 3B shows a shunt formed of an elongate wick member through which fluid can flow.

15 Figure 3C shows a shunt that combines a tube and a wicked member.

Figure 4 shows the shunt including one or more retention structures.

Figure 5 shows an exemplary embodiment of a delivery system that can be used to deliver the shunt into the eye.

Figure 6A shows another embodiment of a delivery system.

20 Figure 6B shows another embodiment of a delivery system.

Figures 6C and 6D show the delivery system of Figure 6B during actuation.

Figures 6E-6G show a distal region of the delivery system during various stages of actuation.

25 Figure 6H shows an enlarged view of an exemplary distal region of an applier of the delivery system.

Figure 7 shows an enlarged view of an end region of the shunt.

Figure 8 shows another embodiment of the shunt wherein a plurality of holes are located on the side walls of the shunt.

Figure 9A shows another embodiment of the shunt that includes an elongate portion of fixed size and one or more expansion members.

Figure 9B shows an embodiment of the expansion members that are formed of splayed tines.

5 Figure 10 shows another embodiment of the shunt that includes a retaining member located on the proximal end of the shunt.

Figure 11 shows an embodiment of the shunt that includes one or more slots.

Figure 12 shows an embodiment of the shunt that includes a distal coil member.

10 Figure 13 shows a distal region of an embodiment of the shunt that includes a distal coil member and a sharpened distal end.

Figure 14 shows a cross-sectional view of the eye and a viewing lens.

Figure 15A shows the delivery system positioned for penetration into the eye.

15 Figure 15B shows an embodiment wherein the delivery system is connected to an energy source.

Figure 16 shows an enlarged view of the anterior region of the eye with a portion of the delivery system positioned in the anterior chamber.

Figure 17 shows the distal tip of the applicator positioned within the suprachoroidal space.

20 Figure 18 shows a shunt having a skirt.

Figure 19 shows a shunt that is equipped with a pronged skirt.

Figure 20 shows the skirted shunt positioned in the eye.

Figure 21 shows a shunt implanted in the eye so as to provide a fluid pathway between the anterior chamber and the suprachoroidal space.

25 Figures 22 and 23 shows shunts that include external fluid flow features.

Figure 24, 25A, and 25B shows a shunt that includes an elongate outer member mounted over a plug member.

Figure 26 shows an embodiment of the shunt formed of a sponge-like flow member.

Figure 27 shows a shunt as in Figure 26 having an internal lumen.

Figure 28 shows an embodiment of the shunt that includes a pair of anchor members located on opposite ends of the shunt.

Figure 29 shows an end region of the shunt that includes slices.

5 Figure 30 shows an embodiment of the shunt with outer sleeves.

Figure 31 shows another embodiment of the shunt with sleeves.

Figure 32 shows another embodiment of the shunt, which has a coiled structure.

10 Figures 33A and 33B and 34 show embodiments of the shunt that include a grasping loop.

Figure 35 shows an embodiment of an elongate device with a snare that can be positioned inside a shunt.

Figure 36 shows an embodiment of a spatula-shaped end region of a shunt.

Figure 37 shows a shunt having an atraumatic tip.

15 Figure 38 shows an embodiment wherein the shunt that includes a resilient region.

Figures 39, 40A, and 40B show alternate embodiments of the shunt.

Figure 41 shows an embodiment of the shunt with holes that communicate with an internal lumen.

20 Figures 42A, 42B, and 43 show embodiments of the shunt that include valved regions.

Figures 44 and 45 show embodiments of the shunt that include one or more bulbous elements.

25 Figures 46 and 47 show embodiments of the bulbous element shunt positioned in the suprachoroidal space.

Figure 48 shows an embodiment of the shunt that includes a bullet-shaped tip member.

Figure 49 shows an embodiment of a shunt that mounts over a mandrel.

Figures 50 and 51A show embodiments of shunts that change shape after removal from a mandrel.

Figure 51B shows another embodiment of a shunt.

Figure 51C shows another embodiment of a shunt.

5 Figure 52 shows a shunt with a curved proximal region positioned in the eye.

Figure 53 shows a schematic, front view of the upper region of a patient's face including the two eyes.

10 Figures 54A and 54B show perspective and plan views of an exemplary delivery pathway of the applicator and shunt during implantation of the shunt into the eye.

Figures 55A-55D show plan and perspective views of a delivery system being inserted into the eye.

Figure 56 shows a plan view of an exemplary delivery pathway.

15 Figure 57 shows a perspective view of an alternate delivery pathway into the eye.

Figures 58A-58D show yet another delivery pathway into the eye.

Figure 59 shows a shunt having an extension sized and positioned such that a proximal end is positioned over a crest of the iris.

Figure 60 shows a shunt with a curved extension positioned in the eye.

20 Figure 61 shows another embodiment wherein the shunt extends through the iris such that the proximal end and the internal lumen of the shunt communicate with the posterior chamber.

Figures 62 and 63 show a trans-scleral delivery approach for the shunt.

DETAILED DESCRIPTION

25 Figure 1 is a cross-sectional, perspective view of a portion of the eye showing the anterior and posterior chambers of the eye. A shunt 105 is positioned inside the eye such that a proximal end 110 is located in the anterior chamber 115 and a distal end 120 is located in the suprachoroidal space (sometimes referred to as the

perichoroidal space). The shunt 105 is illustrated in Figure 1 as an elongate element having one or more internal lumens through which aqueous humour can flow from the anterior chamber 115 into the suprachoroidal space. Embodiments of the shunt 105 with various structural configurations are described in detail below.

5 Exemplary Eye Anatomy

Figure 2 is a cross-sectional view of a human eye. The eye is generally spherical and is covered on the outside by the sclera S. The retina R lines the inside posterior half of the eye. The retina registers the light and sends signals to the brain via the optic nerve. The bulk of the eye is filled and supported by the vitreous body, a clear, jelly-like substance.

The elastic lens L is located near the front of the eye. The lens L provides adjustment of focus and is suspended within a capsular bag from the ciliary body CB, which contains the muscles that change the focal length of the lens. A volume in front of the lens L is divided into two by the iris I, which controls the aperture of the lens and the amount of light striking the retina. The pupil is a hole in the center of the iris I through which light passes. The volume between the iris I and the lens L is the posterior chamber PC. The volume between the iris I and the cornea is the anterior chamber AC. Both chambers are filled with a clear liquid known as aqueous humour.

The ciliary body CB continuously forms aqueous humour in the posterior chamber PC by secretion from the blood vessels. The aqueous humour flows around the lens L and iris I into the anterior chamber and exits the eye through the trabecular meshwork, a sieve-like structure situated at the corner of the iris I and the wall of the eye (the corner is known as the iridocorneal angle). Some of the aqueous humour filters through the trabecular meshwork into Schlemm's canal, a small channel that drains into the ocular veins. A smaller portion rejoins the venous circulation after passing through the ciliary body and eventually through the sclera (the uveoscleral route).

Glaucoma is a disease wherein the aqueous humor builds up within the eye. In a healthy eye, the ciliary processes secrete aqueous humor, which then passes through the angle between the cornea and the iris. Glaucoma appears to be the result of clogging in the trabecular meshwork. The clogging can be caused by the exfoliation of cells or other debris. When the aqueous humor does not drain properly from the clogged meshwork, it builds up and causes increased pressure in the eye, particularly on the blood vessels that lead to the optic nerve. The high pressure on the blood vessels can result in death of retinal ganglion cells and eventual blindness.

10 Closed angle (acute) glaucoma can occur in people who were born with a narrow angle between the iris and the cornea (the anterior chamber angle). This is more common in people who are farsighted (they see objects in the distance better than those which are close up). The iris can slip forward and suddenly close off the exit of aqueous humor, and a sudden increase in pressure within the eye follows.

15 Open angle (chronic) glaucoma is by far the most common type of glaucoma. In open angle glaucoma, the iris does not block the drainage angle as it does in acute glaucoma. Instead, the fluid outlet channels within the wall of the eye gradually narrow with time. The disease usually affects both eyes, and over a period of years the consistently elevated pressure slowly damages the optic nerve.

20 **Shunt and Delivery System**

Figure 3A shows a first embodiment of the shunt 105. As mentioned, the shunt 105 is an elongate member having a proximal end 110, a distal end 120, and a structure that permits fluid (such as aqueous humour) to flow along the length of the shunt such as through the shunt or around the shunt. In the embodiment of Figure 3A, the elongate member includes at least one internal lumen 305 having at least one opening for ingress of fluid and at least one opening for egress of fluid. In the embodiment of Figure 3A, the shunt includes a single opening in the proximal end 110 and a single opening in the distal end 120 that both communicate with the

internal lumen 305. However, the shunt 105 can include various arrangements of openings that communicate with the lumen(s), as described below.

The internal lumen 305 serves as a passageway for the flow of aqueous humour through the shunt 105 directly from the anterior chamber to the
5 suprachoroidal space. In addition, the internal lumen 305 can be used to mount the shunt 105 onto a delivery system, as described below. The internal lumen 305 can also be used as a pathway for flowing irrigation fluid into the eye generally for flushing or to maintain pressure in the anterior chamber, or using the fluid to hydraulically create a dissection plane into or within the suprachoroidal space. In
10 the embodiment of Figure 3A, the shunt 105 has a substantially uniform diameter along its entire length, although the diameter of the shunt can vary along its length, as described below. Moreover, although the shunt 105 is shown as having a circular cross-sectional shape, the shunt can have various cross-sectional shapes (such as an oval or rectangular shape) and can vary in cross-sectional shape moving along
15 its length. The cross-sectional shape can be selected to facilitate easy insertion into the eye.

The shunt 105 can include one or more features that aid in properly positioning the shunt 105 in the eye. For example, the shunt can have one or more visual, tomographic, echogenic, or radiopaque markers 112 that can be used to aid
20 in placement using any of the devices referenced above tuned to its applicable marker system. In using the markers to properly place the implant, the shunt is inserted in the suprachoroidal space, until the marker is aligned with a relevant anatomic structure, for example, visually identifying a marker on the anterior chamber portion of the shunt that aligns with the trabecular meshwork, or scleral
25 spur, such that an appropriate length of the shunt remains in the anterior chamber. Under ultrasound, an echogenic marker can signal the placement of the device within the suprachoroidal space. Any marker can be placed anywhere on the device to provide sensory feedback to the user on real-time placement, confirmation of

placement or during patient follow up. Other structural features are described below.

The shunt 105 can also include structural features that aid in anchoring or retaining the implanted shunt 105 in the eye. For example, as shown in Figure 4, the shunt 105 can include one or more retaining or retention structures 410, such as protrusions, wings, tines, or prongs, that lodge into anatomy to retain the shunt in place. The retention structures 410 can be deformable or stiff. The retention structures 410 can be made of various biocompatible materials. For example, the retention structures 410 can be made from thin 0.001" thick polyimide, which is flexible, thin 0.003" silicone elastomer which is also flexible, or stainless steel or Nitinol. Alternatively, the retention structures 410 could be rings of polyimide. It should be appreciated that other materials can be used to make the retention structures 410. The shape of retention structures 410 can vary. For example, Figure 4 shows the retention structures 410 as barb-shaped with pointed edges of the barbs pointing in opposite directions. In other embodiment, the retention structures 410 can be rectangular, triangular, round, combinations thereof, or other shapes. Additional embodiments of retention structures 410 are described below.

Other anchoring or retaining features can be employed with the shunt 105. For example, one or more hairs, such as human hairs, or synthetic hairs made from polymers, elastomers or metals can be attached to the shunt. The hairs can be glued or thermally bonded to the shunt. The hairs, if they are polyimide, can be attached to the shunt by dipping and polymerized by heat and pressure if the dipping material is polyimide. The hairs can be crimped to the shunt by rings. Alternatively, the shunt can have through-hole features that the hairs can be threaded through and tied or knotted. The hairs can be overmolded onto the shunt body. The hairs are positioned relative to the shunt such that at least a portion of the hair extends outwardly from the shunt for anchoring within or against the tissue of the eye. Various anchoring and retaining features are described herein and it

should be appreciated that the features can be implemented in any of the shunt embodiments described herein.

The retaining features, such as wings or collars, can be manufactured by various methods. In one embodiment, the retaining features can be inherent in the raw material from which the shunt is constructed. The shunt can be machined or laser ablated from a unitary rod or block of stock of material with the material subtracted or removed, leaving the retaining features behind.

Alternatively, the retaining features can be manufactured as separate parts and assembled onto the shunt. They can be joined to the shunt by a friction fit or attached with biocompatible adhesives. They can fit into grooves, holes or detents in the body of the shunt to lock them together. If the retaining features are constructed from hairs or sutures, they can be threaded or tied onto the shunt. Alternatively, the retaining features can be overmolded onto the shunt via an injection molding process. Alternatively, the entire shunt and retention features can be injection molded in one step. Alternatively, the retaining features can be formed into the shunt with a post-processing step such as flaring or thermoforming parts of the shunt.

The shunt 105 can be made of various materials, including, for example, polyimide, Nitinol, platinum, stainless steel, molybdenum, or any other suitable polymer, metal, metal alloy, or ceramic biocompatible material or combinations thereof. Other materials of manufacture or materials with which the shunt can be coated or manufactured entirely include Silicone, PTFE, ePTFE, differential fluoropolymer, FEP, FEP laminated into nodes of ePTFE, silver coatings (such as via a CVD process), gold, prolene/polyolefins, polypropylene, poly(methyl methacrylate) (PMMA), acrylic, PolyEthylene Terephthalate (PET), Polyethylene (PE), PLLA, and parylene. The shunt 105 can be reinforced with polymer, Nitinol, or stainless steel braid or coiling or can be a co-extruded or laminated tube with one or more materials that provide acceptable flexibility and hoop strength for adequate lumen support and drainage through the lumen. The shunt can alternately be

manufactured of nylon (polyamide), PEEK, polysulfone, polyamideimides (PAI), polyether block amides (Pebax), polyurethanes, thermoplastic elastomers (Kraton, etc), and liquid crystal polymers.

Any of the embodiments of the shunt 105 described herein can be coated on its inner or outer surface with one or more drugs or other materials, wherein the drug or material maintains the patency of the lumen or encourages in-growth of tissue to assist with retention of the shunt within the eye or to prevent leakage around the shunt. The drug can also be used for disease treatment. The shunt can also be coated on its inner or outer surface with a therapeutic agent, such as a steroid, an antibiotic, an anti-inflammatory agent, an anticoagulant, an antiglaucomatous agent, an anti proliferative, or any combination thereof. The drug or therapeutic agent can be applied in a number of ways as is known in the art. Also the drug can be embedded in another polymer (nonabsorbable or bioabsorbable) that is coated on the shunt.

The shunt can also be coated or layered with a material that expands outward once the shunt has been placed in the eye. The expanded material fills any voids that are positioned around the shunt. Such materials include, for example, hydrogels, foams, lyophilized collagen, or any material that gels, swells, or otherwise expands upon contact with body fluids.

The shunt can also be covered or coated with a material (such as polyester, ePTFE(also known as GORETEX®), PTFE that provides a surface to promote healing of the shunt into the surrounding tissue. In order to maintain a low profile, well-known sputtering techniques can be employed to coat the shunt. Such a low profile coating would accomplish a possible goal of preventing migration while still allowing easy removal if desired.

In another embodiment shown in Figure 3B that can be useful in some glaucoma cases depending on how much flow is desired, the shunt 105 is formed of an elongate wick member through which fluid can flow. The wick member can be formed of a single strand of material or can be formed of a plurality of strands that

are interconnected, such as in a twisted, braided, or woven fashion, and through or along which fluid can flow. The wick member(s) do not necessarily include internal lumens, as flow through the wick member can occur via capillary action. In the case of a solid polymer wick, certain surface detents can provide flow lumens
5 between the central body member and the tissue of the suprachoroidal space.

The features of the shunts shown in Figure 3A and 3B can be combined as shown in Figure 3C. Thus, the shunt 105 can include one or more wick members 315 in fluid communication with an internal lumen 305 (or external lumen) of an elongate member. The flow of aqueous humour occurs both through the internal
10 lumen 305 and through or along the wick member 315.

In an exemplary embodiment, the shunt has a length in the range of 0.1" to 0.75" and an inner diameter for a flow path in the range of 0.002" to 0.015". In an embodiment, the inner diameter is 0.012", 0.010", or 0.008". A wicking shunt can have a diameter in the range of 0.002" to 0.025". In the event that multiple shunts
15 are used, and for example each shunt is 0.1", the fully implanted device can create a length of 0.2" to 1.0", although the length can be outside this range. An embodiment of the shunt is 0.250" long, 0.012" in inner diameter, and 0.015" in outer diameter. One embodiment of the shunt is 0.300" long.

The shunt 105 has a column strength sufficient to permit the shunt 105 to be
20 inserted into suprachoroidal space such that the distal tip of the shunt 105 tunnels through the eye tissue (such as the ciliary body) without structural collapse or structural degradation of the shunt 105. In addition, the surface of the inner lumen 305 is sufficiently smooth relative to the delivery device (described in detail below) to permit the shunt 105 to slide off of the delivery device during the delivery process.
25 In an embodiment, the column strength is sufficient to permit the shunt to tunnel through the eye tissue into the suprachoroidal space without any structural support from an additional structure such as a delivery device.

The shunt 105 can be configured to transition between a first state of reduced size and a second state of expanded size. For example, the shunt 105 can be in a

first state wherein the shunt 105 has a reduced radial size and/or overall length in order to facilitate fitting the shunt through a small portal during delivery. The shunt can then transition to a second state of increased radial size and/or overall length. The shunt can also change cross sectional shape along the length.

5 The transition between the first and second states can be implemented in various manners. For example, the shunt can be manufactured of a material such as Nitinol that deforms in response to temperature variations or a release of a constraining element. Thus, the shunt can be self-expanding or self-restricting at various locations along the length. In another embodiment or in combination with a
10 self-expanding shunt, the shunt can be expanded manually, such as through use of an expansion balloon or by passing the shunt along a pre-shaped device, such as a reverse-tapered delivery trocar that increases in diameter. In addition, the shunt can be positioned inside a sheath during delivery wherein the sheath maintains the shunt in the first state of reduced size. Upon delivery, the sheath can be removed to
15 permit the shunt to expand in size.

Figure 5 shows an exemplary delivery system 510 that can be used to deliver the shunt 105 into the eye pursuant to methods described in detail below. The delivery system 510 includes a handle component 515 that controls a shunt placement mechanism, and a delivery component 520 that removably couples to the
20 shunt 105 for delivery of the shunt 105 into the eye. The delivery component 520 includes an elongate applier 525. In one embodiment, the applier 525 has a sharpened distal tip. The applier 525 is sized to fit through the lumen in the shunt 105 such that the shunt 105 can be mounted on the applier 525. The applier 525 can have a cross-sectional shape that complements the cross-sectional shape of
25 the internal lumen of the shunt 105 to facilitate mounting of the shunt onto the applier 525. It should be appreciated the applier 525 does not have to employ a sharpened distal tip. The applier 525 can have an atraumatic or blunt distal tip such that it serves as a component for coupling to the shunt, or performing blunt dissection, rather than as a cutting component.

The delivery component 520 also includes a shunt deployment or advancing structure 530 positioned on a proximal end of the applier 525. The advancing structure 530 can be an elongated tube that is positioned over the applier 525. The delivery system 510 can be actuated to achieve relative, sliding movement between the advancing structure 530 and the applier 525. For example, the advancing structure 520 can be moved in the distal direction (as represented by the arrow 532), while the applier 525 remains stationary to push or otherwise advance the shunt 105 along the applier 525 for delivery of the shunt 105 into the eye. In an alternate embodiment, the applier 525 withdraws distally into the advancing structure 530 to remove the shunt 105 from the applier 525, as described below with reference to Figure 6B. In yet another embodiment, both the advancing structure 530 and the applier 525 move relative to one another to remove the shunt 105.

In an embodiment, the applier 525 can have a length sufficient to receive a plurality of shunts in an end-to-end series arrangement on the applier 525. In this manner, multiple shunts 105 can be loaded onto the applier 525 and delivered one at a time such that the shunts collectively form an elongated lumen of sufficient length for adequate drainage. This permits relatively short length shunts that can be collectively used in various eye sizes. In addition, multiple shunts can be placed in multiple separate locations within one eye.

The applier 525 or any portion of the delivery component 520 can have an internal lumen that extends along its length for receipt of a guidewire that can be used during delivery of the shunt 105. The internal lumen in the delivery component 520 can also be used for the flow of fluid in order to irrigate the eye. The internal lumen can be sufficiently large to receive the shunt 105 such that the shunt 105 is mounted inside the applier 525, rather than over the applier 525, during delivery.

The handle component 515 of the delivery system 510 can be actuated to control delivery of the shunt 105. In this regard, the handle component 515 includes an applier control 540 that can be actuated to cause the applier 525 to extend in length in the distal direction or to retract in the opposite direction (proximal

direction). The handle component 515 also includes an implant advancing actuator 535 that can be actuated to selectively move the advancing structure 530 along the applier 525 in the proximal or distal direction. In this manner, the advancing structure 530 can be used to push the shunt 105 in the distal direction and off of the
5 applier 525 during delivery, or else to hold the shunt 105 in a fixed location in the eye while the applier 525 is withdrawn.

The handle component 515 can be adapted such that it can be actuated using only a single hand. In addition, the delivery system 510 can include an actuation member that is separate from the handle 515 such that the operator can
10 use a foot to actuate the delivery system 510. For example, a foot pedal or hydraulics can be coupled to or incorporated within the delivery system 510 to save the use of the physician's hand at the worksite. Thus, the physician simply positions a cannula or delivery system with his or her hands and uses the foot pedal to advance the shunt. PCT Publication No. WO06012421, which is incorporated
15 herein by reference in its entirety, describes an exemplary hydraulic assist for an ablation catheter with a steerable tip.

In another embodiment, some of the functions of the applier 525 and the shunt 105 are combined. That is, the distal tip of the shunt 105 can have a pointed or other type of shape (such as a beveled or blunted shape) on the distal end that
20 facilitates penetration of the shunt 105 through tissue. Exemplary methods for delivering the shunt 105 into the eye are described in detail below.

As mentioned, the applier 525 can be equipped with one or more mechanisms that cause expansion of the shunt 105. For example, the applier 525 can include an expandable structure, such as an inflatable sheath, that is mounted
25 over a solid core of the applier 525. The inflatable sheath is positioned at least partially within the internal lumen of the shunt 105 when the shunt 105 is mounted on the applier 525. During delivery of the shunt 105, the inflatable sheath is expanded when the shunt 105 is positioned in the appropriate location in the eye to expand the shunt 105 and cause the shunt 105 to lodge in the location. The sheath

is then deflated or otherwise reduced in size to permit the applier 525 to be withdrawn from the shunt 105. Exemplary methods are described below.

The applier 525 can be made of various materials, including, for example, stainless steel and Nitinol. The applier 525 can be straight (as shown in Figure 5) or the applier 525 can be curved along all or a portion of its length (as shown in Figure 6A) in order to facilitate proper placement through the cornea. In this regard, the curvature of the applier 525 can vary. For example, the applier 525 can have a radius of curvature of 3mm to 50mm and the curve can cover from 0 degrees to 180 degrees. In one embodiment, the applier 525 has a radius of curvature that corresponds to or complements the radius of curvature of a region of the eye, such as the suprachoroidal space. For example, the radius of curvature can be around 12 mm. Moreover, the radius of curvature can vary moving along the length of the applier 525. There can also be means to vary the radius of curvature of portions of the applier 525 during placement.

The applier can also have a structure that enables or facilitates use of the applier 525. For example, the distal tip of the applier 525 can have a shape that facilitates blunt dissection of targeted tissue such as to facilitate dissection into the suprachoroidal space. In this regard, the distal tip of the applier 525 can have a flat, shovel, spade, etc. shape, for example.

Figure 6B shows another embodiment of the delivery device 510. The handle component 515 includes an actuator comprised of a knob 550 that can slide relative to the handle component 515. The knob 550 serves as an actuator that controls relative, sliding movement between the advancing member 530 and the applier 525. For example, with reference to Figures 6C and 6D, the advancing member 530 can be fixed relative to the handle component 515. In a first state shown in Figure 6C, the applier 525 is extended outwardly relative to the advancing member 530. Movement of the knob 550, such as in the proximal direction, causes the applier 525 to slide proximally into the advancing element 530 as shown in Figure 6D.

This is described in more detail with reference to Figure 6E, which shows the shunt 105 mounted on the applier 525 distal of the advancing structure 530. When the knob 550 is actuated, the applier 525 slides in the proximal direction and into the advancing structure 530, as shown in Figure 6F. The proximal edge of the shunt 105 abuts the distal edge of the advancing structure 530 to prevent the shunt 105 from sliding in the proximal direction. Thus, the applier 525 gradually withdraws from the shunt 105. As shown in Figure 6G, the applier 525 can be fully withdrawn into the advancing structure 530 such that the shunt 105 is released from the applier 525.

Figure 6H shows an enlarged view of an exemplary distal region 537 of the applier 525. The distal region 537 of the applier 525 can be shaped to facilitate an approach into the suprachoroidal space. In this regard, as mentioned above, the distal region 537 can have a curved contour that compliments the curved contour of the dissection plane, such as the suprachoroidal space.

At least a portion of the applier 525 can be flexible. For example, the distal region 537 of the applier 525 can be flexible such that it conforms to the shape of the shunt 105 when the shunt 105 is mounted on the distal region 537. The distal region 537 can also conform to the shape of the advancing element 530 when the applier 525 is withdrawn into the advancing element 530.

Various other embodiments of the shunt 105 are now described. The reference numeral 105 is used to refer to all embodiments of the shunt and it should be appreciated that features in the various embodiments can be combined with other embodiments. As mentioned, the shunt 105 can include various types of structures and mechanisms for retaining or otherwise anchoring the position of the shunt 105 in the eye. For example, the shunt 105 can be equipped with a structure (such as a mesh structure or spray coating) that facilitates endothelial growth of tissue around the shunt for permanent placement of the shunt.

Figure 7 shows an enlarged view of an end region, such as the distal end region, of the shunt 105. The end region includes retaining structures comprised of

one or more fenestrations, slits or slots 705 located on the shunt 105. The slots 705 are shown arranged in a series along the end region of the shunt 105, although it should be appreciated that the spatial configuration, size, and angle of the slots 705 can vary. The shunt 105 shown in Figure 7 has a distal wall 710 that at least
5 partially encloses the distal end of the internal lumen. The distal wall 710 can have a slot 705 for fluid flow into and out of the lumen. Alternately, the distal wall 710 can be absent such that an opening is present for the flow of fluid. The slots can operate to allow fluid flow in addition to the central lumen of the shunt 105.

10 The slots 705 form edges that interface with surrounding tissue to prevent the shunt 105 from becoming dislodged once implanted in the eye. The slots 705 form holes that communicate with the internal lumen of the shunt 105 for inflow and outflow of aqueous humour relative to the lumen. The proximal end of the shunt can also be equipped with an arrangement of slots 705.

15 Figure 8 shows another embodiment of the shunt 105 wherein a plurality of holes are located on the side walls of the shunt 105 and interspersed along the length of the shunt 105. The holes facilitate the flow of fluid into and out of the internal lumen of the shunt 105. The shunt 105 can be configured such that it initially does not have any holes. After the shunt 105 is placed in the eye, one or more holes can be formed in the shunt, such as by applying a laser (e.g., a YAG
20 laser) to the shunt 105 or using other means to form the holes.

Each of the holes can communicate with a separate flow path that extends through the shunt 105. That is, the shunt 105 can include a plurality of internal lumens wherein each internal lumen communicates with one or more of the holes in side wall of the shunt.

25 Figure 9A shows another embodiment of the shunt 105 that includes an elongate portion 905 of fixed size and one or more expansion members 910. The elongate portion 905 includes an internal lumen and one or more openings for ingress and egress of fluid relative to the lumen. The expansion members 910 are configured to transition between a first state of reduced size and a second state of

expanded or increased size. The structure of the expansion members 910 can vary. In the illustrated embodiment, each expansion member 910 is formed of a plurality of axially-extending rods or tines that are connected at opposed ends. The rods can deform outward along their length to expand the radial size of the expansion member 910. The expansion of the expansion members 910 can be implemented in various manners, such as by using an expansion balloon or by manufacturing the expansion members of a material such as Nitinol that deforms or expands in response to temperature variations or a retractable sheath 915 that allows expansion of a shunt formed from a resilient material. The expansion members can also be biased outward such that they self-expand when unrestrained.

As shown in Figure 9B, an embodiment of the expansion members 910 are formed of tines that are splayed or fanned outward. The tines are configured to hold tissue of the suprachoroidal space open. Either one or both of the expansion members 910 can include splayed tines. For example, the expansion member 910a can be as configured in Figure 9A, while the expansion member 910b can be as configured in Figure 9B (or vice-versa). Furthermore, the shunt can include three or more expansion members.

The expansion members 910 can be biased toward the expanded state such that, when unopposed, the expansion members 910 automatically move toward the expanded state. In such a case, each of the expansion members 910 can be positioned within a sheath 915 during delivery, wherein the sheath 915 maintains the expansion members 910 in the reduced-size state. The sheath 915 is removed from the expansion members to permit the expansion members 910 to self-expand. The sheath 915 can have a strong hoop and tensile strength to hold the expansion members 910 in an unexpanded state until the shunt 105 is in a proper place in the eye. In one embodiment, the sheath 915 is manufactured of PolyEthylene Terephthalate (PET).

The embodiment of Figure 9A includes a first expansion member 910a on a distal end of the shunt 105 and a second expansion member 910b on a proximal

end of the shunt 105. It should be appreciated that the quantity and location of the expansion members 910 on the shunt can vary. For example, the shunt 105 can include only a single expansion member 910 on either the proximal end or the distal end, or could include one or more expansion members interspersed along the length of the portion 905. Expansion members can be configured in other geometries e.g. latticed, coiled or combinations of each.

Figure 10 shows another embodiment of the shunt 105 that includes a retaining member 1005 located on the proximal end of the shunt 105. The retaining member 1005 has an enlarged size with respect to the remainder of the shunt and has a shape that is configured to prevent the shunt from moving further into the suprachoroidal space after being properly positioned. The enlarged shape of the retaining member 1005 can lodge against tissue to prevent movement of the shunt 105 into or out of a predetermined location, such as the suprachoroidal space. The retaining member 1005 of Figure 10 has a funnel or cone-like shape, although the retaining member 1005 can have various shapes and sizes that are configured to prevent the shunt from moving further into the suprachoroidal space. For example, the retaining member 1005 can have a plate or flange-like shape.

The shunt 105 of Figure 10 is tapered moving along its length such that the diameter of the shunt 105 gradually reduces moving in the distal direction. The distal direction is represented by the arrow 532 in Figure 10. The tapered configuration can facilitate a smooth insertion into the eye. The taper can exist along the entire length of the shunt or it can exist only along one or more regions, such as a distal region. Further, the shunt can have a bulbous section at approximately its midpoint to create an additional means to anchor. The bulbous section can be an expandable member or balloon element. Shunts with bulbous sections are described in detail below.

As mentioned, the shunt 105 includes an internal lumen. The lumen can have a uniform diameter along the length of the shunt or that can vary in diameter along the length of the shunt. In this regard, the diameter of the internal lumen can

taper in a manner that achieves a desired fluid flow rate through the shunt. Thus, the diameter of the lumen can be varied to regulate fluid flow through the shunt. Flow regulation can also be achieved by variation in size, quantity, and/or position of holes 1010 in the distal region of the shunt 105, wherein the holes 1010
5 communicate with the internal lumen. Thus, the holes 1010 can have shapes, sizes, and quantities that are selected to achieve a desired intraocular pressure of the eye as a result of the flow of aqueous humour through the shunt. In addition, the use of multiple holes permit fluid to flow through the shunt 105 even when one of the holes 1010 is blocked.

10 During delivery of the shunt 105, the holes 1010 can be positioned so as to align with predetermined anatomical structures of the eye. For example, one or more holes 1010 can align with the suprachoroidal space to permit the flow of aqueous humour into the suprachoroidal space, while another set of holes 1010 aligns with structures proximal to the suprachoroidal space, such as structures in the
15 ciliary body or the anterior chamber of the eye. The shunt can have visual markers along its length to assist the user in positioning the desired portion of the shunt within the anterior chamber. Further, the shunt and delivery system can employ alignment marks, tabs, slots or other features that allow the user to know alignment of the shunt with respect to the delivery device.

20 Figure 11 shows an embodiment of the shunt 105 that includes one or more slots 1105 that are positioned around the circumference of the shunt. The slots 1105 provide variations in the shunt structure that permit the shunt to flex during delivery such as to enable proper placement of the shunt 105 from the anterior chamber of the eye to the suprachoroidal space. The shunt 105 can also be
25 manufactured of a flexible material with or without slots 1105. The shunt 105 can have other features that provide flexibility to the shunt. For example, the shunt can be scored or laser cut for flexibility at various locations along the shunt. The scores can be located at various positions along the length of the shunt 105 to provide localized variation in the flexibility of the shunt. For example, a distal region can

have a plurality of scores to provide increased flexibility, while a proximal region includes a reduced number of scores that provide less flexibility than the distal region.

Figure 12 shows an embodiment of the shunt 105 that includes a distal coil member 1205. The coiled configuration of the coil member 1205 provides increased flexibility to the distal region of the shunt 105 to facilitate traction into the suprachoroidal space. Moreover, the coil member 1205 can facilitate fluid flow from the internal lumen into the suprachoroidal space. The coil member 1205 can permit a screwing motion to advance and/or secure the shunt 105 in the eye. The distal tip of the shunt 105 can have an atraumatic shape, such as a ball shape (as shown in Figure 12). The distal tip can alternately have a sharpened tip and a shape with barbs that retains the shunt in the eye, as shown in Figure 13. Any of the features that are described herein as being on the distal tip could also be located on the proximal tip of the shunt.

15 **Exemplary Methods of Delivery and Implantation**

An exemplary method of delivering and implanting the shunt into the eye is now described. In general, the shunt is implanted using the delivery system by accessing the scleral spur to create a low profile dissection in the tissue plane between the choroid and the sclera. The shunt is then secured in the eye so that it provides communication between the anterior chamber and the suprachoroidal space.

Figure 14 shows a cross-sectional view of the eye. A viewing lens 1405 (such as a gonioscopy lens represented schematically in Figure 14) is positioned adjacent the cornea. The viewing lens 1405 enables viewing of internal regions of the eye, such as the scleral spur and scleral junction, from a location in front of the eye. The viewing lens 1405 can optionally include one or more guide channels 1410 that are sized to receive the delivery portion 520 of the delivery device 510. It should be appreciated that the locations and orientations of the guide channels 1410 in Figure 14 are merely exemplary and that the actual locations and

orientations can vary depending on the angle and location where the shunt 105 is to be delivered. An operator can use the viewing lens 1405 during delivery of the shunt into the eye. The viewing lens 1405 can have a shape or cutout that permits the surgeon to use the viewing lens 1405 in a manner that does not cover or impede
5 access to the corneal incision. Further, the viewing lens can act as a guide through which a delivery device 510 can be placed to predetermine the path of the device as it is inserted through the cornea.

An endoscope can also be used during delivery to aid in visualization. For example, a twenty-one to twenty-five gauge endoscope can be coupled to the shunt
10 during delivery such as by mounting the endoscope along the side of the shunt or by mounting the endoscope coaxially within the shunt. Ultrasonic guidance can be used as well using high resolution bio-microscopy, OCT and the like. Alternatively, a small endoscope can be inserted through another limbal incision in the eye to image the tissue during the procedure.

In an initial step, one or more shunts 105 are mounted on the delivery device
15 510 for delivery into the eye. As mentioned, at least one shunt 105 can be mounted over the applier 525 or can be mounted within the applier 525. The eye can be viewed through the viewing lens 1405 or other viewing means such as is described above, in order to ascertain the location where the shunt 105 is to be delivered. At
20 least one goal is to deliver the shunt 105 in the eye so that it is positioned such that the internal lumen of the shunt provides a fluid pathway between the anterior chamber and the suprachoroidal space. If a tube shunt having an internal lumen is used, then the internal lumen is positioned such that at least one ingress to the lumen communicates with the anterior chamber and at least one egress
25 communicates with the suprachoroidal space. If a wick shunt is used, then the wick member can communicate with both the anterior chamber and the suprachoroidal space. As mentioned, the tube member and wick member can be combined. In such a case, the internal lumen can be open into the anterior chamber and be open

at least partially into the suprachoroidal space, while the wick member extends further into the suprachoroidal space.

With reference to Figure 15A, the delivery device 510 is positioned such that the distal tip of the applier 525 or the shunt 105 itself can penetrate through the cornea. In this regard, an incision is made through the eye, such as within the
5 limbus of the cornea. In an embodiment, the incision is very close to the limbus, such as either at the level of the limbus or within 2 mm of the limbus in the clear cornea. The applier 525 can be used to make the incision or a separate cutting device can be used. For example, a knife-tipped device or diamond knife can be
10 used to initially enter the cornea. A second device with a spatula tip can then be advanced over the knife tip wherein the plane of the spatula is positioned to coincide with the dissection plane. Thus, the spatula-shaped tip can be inserted into the suprachoroidal space with minimal trauma to the eye tissue.

The incision has a size that is sufficient to permit passage of the shunt
15 therethrough. In this regard, the incision can be sized to permit passage of only the shunt without any additional devices, or be sized to permit passage of the shunt in addition to additional devices, such as the delivery device or an imaging device. In an embodiment, the incision is about 1 mm in size. In another embodiment, the incision is no greater than about 2.85 mm in size. In another embodiment, the
20 incision is no greater than about 2.85 mm and is greater than about 1.5 mm. It has been observed that an incision of up to 2.85 mm is a self-sealing incision. For clarity of illustration, the drawing is not to scale and the viewing lens 1405 is not shown in Figure 15A, although the applier can be guided through one or more guide channels in the viewing lens. The applier 525 can approach the suprachoroidal space from
25 the same side of the anterior chamber as the deployment location such that the applier does not have to be advanced across the iris. Alternately, the applier can approach the location from across the anterior chamber such that the applier is advanced across the iris and/or the anterior chamber. The applier 525 can approach the eye and the suprachoroidal space along a variety of pathways.

Various pathways for approaching the eye and deploying the shunt are described in detail below.

After insertion through the incision, the applier 525 is advanced through the cornea and the anterior chamber. The applier is advanced along a pathway that
5 enables the shunt to be delivered from the anterior chamber into the suprachoroidal space. In one embodiment, the applier travels along a pathway that is toward the scleral spur such that the applier crosses through the scleral spur on the way to the suprachoroidal space. The applier 525 can be pre-shaped, steerable, articulating, or shapeable in a manner that facilitates the applier approaching the suprachoroidal
10 space along a proper angle or pathway.

As mentioned, a guidewire can also be used to guide the applier or the shunt over the guidewire to the proper location in the eye. The guidewire can be looped at a distal end to assist in making suprachoroidal dissection. Once the shunt is properly in place, the loop can be released. If the shunt needs to be removed prior
15 to releasing the loop, the guidewire loop can act as a retrieval mechanism. The loop can be larger than the distal lumen opening of the shunt such that when the guidewire is pulled back, the loop pulls the shunt along with it.

The guidewire can be left in place even after the applier is removed. This enables the user to repeatedly access the site via the guidewire without having to
20 relocate the site in the eye. A cannula can be used to create an access pathway to the delivery site. The delivery tool can then be placed through the cannula. The cannula can remain fixed in place with the viewing lens, and the end of the delivery device can be articulated or steerable such that multiple shunts can be placed from one access site. For example an infusion cannula from Dutch Ophthalmic Research
25 Center (D.O.R.C.) can be used, in particular models that allow for continuous infusion and aspiration to maintain a sufficient working area within the anterior chamber.

As discussed, the distal tip of the applier 525 can be sharp and can also be tapered to facilitate a smooth penetration through the cornea. The distal tip of the

shunt 105 can also be sharp. In addition, the tip of the applier device can be connected to an energy source ES, to allow energy to be delivered to the tip of the applier body to assist in creating the initial corneal stick, and in addition facilitating entry into the suprachoroidal space through the scleral spur. In this embodiment shown schematically in figure 15B, only the distalmost tip is exposed to apply energy to the tissue, and the remaining shaft of the applier is insulated such as with a sleeve made of insulation material. Energy delivery wires are attaching to the applier shaft (such as via the handle) to energize the tip portion, and such wires are also connected to an energy delivery source ES and any required grounding pad.

10 The energy that can be delivered to facilitate the procedure can be RF energy, laser energy, resistive heat energy or ultrasonic energy. An energy delivery system for medical use, such as those produced by Stellertech Research (Mountain View, California) can be employed, for example, to apply RF energy to the tip of the applier. Figure 16 shows an enlarged view of the anterior region of the eye showing

15 the anterior chamber AC, the cornea C, the iris I, the sclera S, and the choroid CH. The suprachoroidal space is at the junction between the sclera and the choroid. The shunt 105 which is mounted on the applier 525, is shown approaching the suprachoroidal space from the anterior chamber. The distal tip of the applier 525 moves along a pathway such that the distal tip is positioned at the scleral spur with

20 the curve of the applier 525 aiming the distal tip toward the suprachoroidal space. In this regard, the applier 525 and/or the shunt 105 can have a radius of curvature that conforms to the radius of curvature of the suprachoroidal space. The surgeon can rotate or reposition the handle of the delivery device in order to obtain a proper approach trajectory for the distal tip of the applier, as described in further detail

25 below.

The scleral spur is an anatomic landmark on the wall of the angle of the eye. The scleral spur is above the level of the iris but below the level of the trabecular meshwork. In some eyes, the scleral spur can be masked by the lower band of the pigmented trabecular meshwork and be directly behind it. With the applier 525

positioned for approach, the applier 525 is then advanced further into the eye such that the distal tip of the applier and/or the shunt penetrates the scleral spur. The penetration through the scleral spur can be accomplished in various manners. In one embodiment, a sharpened distal tip of the applier or the shunt punctures,
5 penetrates, dissects, pierces or otherwise passes through the scleral spur toward the suprachoroidal space. The crossing of the scleral spur or any other tissue can be aided such as by applying energy to the scleral spur or the tissue via the distal tip of the applier 525. The means of applying energy can vary and can include mechanical energy, such as by creating a frictional force to generate heat at the
10 scleral spur. Other types of energy can be used, such as RF laser, electrical, etc.

The applier 525 is continuously advanced into the eye, via the trabecular meshwork and the ciliary body, until the distal tip is located at or near the suprachoroidal space such that a first portion of the shunt 105 is positioned within the suprachoroidal space and a second portion is positioned within the anterior
15 chamber. In one embodiment, at least 1 mm to 2 mm of the shunt (along the length) remains in the anterior chamber. Figure 17 shows the distal tip of the applier 525 positioned within the suprachoroidal space SS. For clarity of illustration, Figure 17 does not show the shunt mounted on the applier, although the shunt 525 is mounted on the applier during delivery. As the applier 525 advances through tissue, the
20 distal tip causes the sclera to peel away or otherwise separate from the choroid to expose the suprachoroidal space.

One method of approach is to advance the applier 525 through the ciliary body as it approaches the suprachoroidal space. The tissue of the sclera is structurally more tough than the ciliary body. As the distal tip of the applier 525
25 passes through the ciliary body and reaches the scleral tissue, the scleral tissue provides an increased resistance to passage of the applier 525 therethrough. Thus, the surgeon will detect an increase in resistance to passage when the distal tip of the applier passes through the ciliary body and reaches the sclera. This can serve as an indication that the distal tip of the applier has reached the suprachoroidal

space. In this regard, the distal region of the applier 525 or the shunt can have a shape, such as a spade shape or a blunt end, that is configured to facilitate creating a dissection plane between the choroid and the sclera and positioning of the distal region of the applier in the suprachoroidal space. This thickness of this dissection plane is approximately the same as the size of the device being placed. The distal region can be flexible or looped to allow for preferential movement into the space between the sclera and choroid.

As mentioned, the delivery device 510 and/or the shunt 105 can be equipped with navigational aides, such as radiopaque markers, or means to enable ultrasonic visualization that assist in proper positioning of the applier and shunt in the eye. Once the applier 525 has been properly positioned, the shunt 105 is advanced off of the applier 525, such as by actuating the implant advancing actuator 535 to move the advancing structure 530 (Figure 5) so as to push the shunt 105 off of the applier into proper placement in the eye.

The shunt 105 can be deployed off of the applier in various manners. For example, as discussed above, the shunt can be pushed off the applier by moving the advancing structure 530 (shown in Figures 5-6G) in the distal direction. In an alternate method, the advancing structure 530 remains stationary and the applier 525 is withdrawn in the proximal direction as was described above with reference to Figures 6E-6G. This can method can be advantageous as the shunt remains stationary during dismount from the applier 525 rather than being moved during dismount. Thus, the shunt can be properly positioned while still on the applier 525. In another method, the applier is distally advanced into the suprachoroidal space while the shunt remains stationary against the advancing structure 530. The advancing structure is then moved distally to push the shunt along the applier. The applier is then withdrawn into the advancing structure to uncouple the shunt from the applier.

The shunt can include structural features that assist in proper placement of the shunt, such as to ensure that the shunt 105 is not advanced any further than

necessary into the eye. For example, the shunt 105 can include a structure, such as the proximal retaining member 1005 (shown in Figure 10), that abuts the scleral spur or another tissue structure to prevent further movement of the shunt into the eye. Figure 18 shows a shunt 105 that is equipped with a skirt 1805 and Figure 19 shows a shunt that is equipped with a pronged skirt 1810. As shown in Figure 20, the skirt 1810 or 1805 abuts and anchors into the ciliary body to prevent the shunt 105 from being advanced any further into the eye. These features can further serve to prevent leakage of fluid around the outside of the shunt. Previous efforts to increase the drainage of the anterior chamber by surgically creating a path between the anterior chamber and the suprachoroidal space, known as cyclodialysis procedures, often caused too much drainage and low pressure ("hypotonia") in the anterior chamber. Concern for excess flow and resultant hypotony can be a major reason why previous efforts have focused on placing shunts through a scleral incision, so the sclera would surround at least a portion of the shunt to prevent flow around the shunt. Therefore, these means for preventing flow around the outside of the shunt can prove essential in enabling placement of a shunt directly from the anterior chamber to the suprachoroidal space without risk of hypotonia.

Figure 21 shows the shunt 105 implanted in the eye so as to provide a fluid pathway between the anterior chamber AC and the suprachoroidal space SS. The shunt 105 was implanted by "tunneling" the shunt toward the suprachoroidal space. That is, as the shunt is advanced toward the suprachoroidal space, the distal tip of the applicator and/or the shunt penetrates the tissue and forms a tunnel through the eye tissue, initially the ciliary body. This differs from a procedure where the shunt is lowered into the eye via a scleral flap that is cut and folded back for access to the implant location. In such a procedure, the implanted shunt is positioned within a cavity that was formed by the folded-back flap. However, in the procedure shown in Figure 21, the shunt 105 is substantially enclosed or surrounded by eye tissue in the region between the anterior chamber and the suprachoroidal space. It also differs from the procedure known as cyclodialysis, that in some cases entirely disinserts the

ciliary body from the scleral spur to relieve the pressure in the anterior chamber, because essentially a puncture is made and the shunt device that is placed, is left in the position of the puncture.

Although Figure 21 shows only a single shunt 105, it should be appreciated
5 that multiple shunts can be implanted in the eye. The shunts can be implanted end-to-end to form a single, elongate fluid pathway or a plurality of shunts can be positioned side-by side or spaced around the circumference of the anterior chamber to form multiple fluid pathways. In addition, a single shunt can be implanted in an initial procedure and additional shunts implanted in one or more subsequent
10 procedures as needed to establish or maintain optimal anterior chamber pressure.

If multiple shunts are used, it is not necessary that all of the shunts (or all openings in a shunt) be initially patent. This will allow the drainage of aqueous humour to be initiated in a controlled manner by selectively opening additional shunts over a period of time. Over time, additional shunts can be activated (i.e.,
15 opened), such as by the insertion of a stylet or other needle-type device, such as during an office visit. The shunts can also be opened or re-opened (if a shunt becomes blocked after implantation) in various manners, such as using a photochemical, laser, RF, ultrasound, or thermal procedure, or combinations thereof. For instance, the shunt can have a single hole or multiple holes along its
20 proximal end or distal end, one or more of which are initially covered by a second tube or other material. Applying light or other energy to the tube could cause the holes to open or could cause the tube to shrink longitudinally, exposing additional openings to increase flow.

In addition, the outer diameter of the shunt or the diameter of the internal
25 lumen can be varied by shrinking or enlarging the shunt using thermal, light, or photochemical activation. For example, the shunt can be initially relatively long and thin. Applying energy or other activation to the shunt could cause it to become shorter and/or larger in diameter, increasing its flow rate.

It is possible that the dissection formed by the shunt can cause a leak between the anterior chamber and the suprachoroidal space. In such a case, the leak can be filled or otherwise plugged with a material (such as a foam or adhesive) or a structure (such as a gasket) that prevents leaking.

5 With reference still to Figure 21, a spacer structure 2110 can optionally be located on the proximal end of the shunt 105. The spacer structure 2110 is a structure that extends outwardly from the shunt 105 to prevent blockage of the proximal end of the shunt 105. With further reference to Figure 21, the structure 2110 can also facilitates grasping the shunt in the event it is necessary to remove
10 the shunt.

In another embodiment, the shunt 105 is not positioned on the applier 525 as the applier is advanced into the eye. In such a case, the handle component 515 of the delivery instrument can be detached from the proximal end of the applier after the applier has been properly positioned in the eye. The shunt 105 is then threaded
15 over the applier, from the proximal end to the distal end, toward the delivery site.

In one implementation, a guide passageway is formed in the eye prior to advancing the applier through the eye. The applier is then advanced through the previously formed passageway rather than using the applier to tunnel through the eye. The passageway can be formed in various manners, such as by using an
20 energy source or phacoemulsification equipment to form the passageway.

Additional Shunt and Delivery System Embodiments

Additional embodiments of the shunt 105 are now described. Figure 22 shows a shunt 105 that includes an elongate core member 2205 that has one or more external fluid flow features, such as flow channels 2210, located on its outer
25 surface. The flow channel(s) 2210 define at least one passageway for the flow of aqueous humour along the length of the shunt 105. The configuration of the flow channel(s) 2210 can vary. In the embodiment of Figure 22, a single flow channel 2210 having a helical or spiral configuration is located on the outer surface of the core member 2205. The core 2205 can also include multiple spiral flow channels.

Figure 23 shows another embodiment, wherein a plurality of straight or substantially straight flow channels are located on the external surface of the core member 2205. The shunt 105 can also include just a single straight flow channel or can include a combination of straight flow channels and flow channels of various curvilinear configurations.

The core 2205 can be a solid piece of material that does not have an internal lumen. A solid core 2205 can form a strong structure and can create a reliable flow path with a reduced risk of structural collapse or tissue ingrowth in the lumen. Alternately, the external flow channels can be combined with an internal lumen that extends through the core 2205. If the core 2205 is solid without an internal lumen, then it can be delivered into the eye through a delivery lumen of a delivery device, such as through an applicator. If the core 2205 includes an internal lumen, then the core can be delivered into the eye mounted over a delivery device, such as over an elongate applicator.

The core 2205 can be manufactured in various ways. For example, the core 2205 can be molded or can be extruded, such as from a biocompatible material or any of the materials described herein. The core 2205 can also be formed of a combination of different materials or can be co-extruded.

Figure 24 shows a shunt 105 that includes an elongate outer member 2405, such as a stent, mounted over a plug member 2410. When this embodiment of the shunt 105 is implanted between the anterior chamber and the suprachoroidal space, the plug member 2410 degrades over time, while the outer member 2405 does not degrade. The outer member 2405 remains in the eye to maintain a patent passageway between the anterior chamber and the suprachoroidal space. The outer member 2405 can be solid (such as an elongate tube) or it can be a mesh. The outer member 2405 can be integrally formed with the plug member 2410 or it can be embedded in varying degrees within the plug member to control the rate of degradation.

The degradation of the plug 2410 can be configured in various manners. For example, the rate of degradation of the plug can be based on the intraocular pressure such that the degradation rate increases as the intraocular pressure increases. Thus, a higher intraocular pressure results in a greater rate of plug degradation than a lower intraocular pressure. In this manner, the rate of degradation of the plug can slow as the intraocular pressure approaches a predetermined value.

An exemplary way of implementing such a feature is to include an internal lumen 2510 in the plug 2410, as shown in Figure 25A. In an initial state, the lumen 2510 has diameter of a reduced size such that a low level of aqueous humour flows through the lumen. The initial state can correspond to the plug being exposed to an initially-high intraocular pressure. The high intraocular pressure causes the plug 2410 to degrade such that the size of the lumen increases. As the size of the lumen increases (as shown in Figure 25B), the level of aqueous humour flow through the lumen also increases, which results in a reduction in intraocular pressure and a reduction in the rate of degradation of the plug.

In an alternate embodiment of the device shown in Figure 24, the stent 2405 does not include an internal member. Thus, a stent 2405 is implanted into the eye in a manner that maintains an opening between the suprachoroidal space and the anterior chamber. The stent 2405 can be a self-expanding or balloon expanding stent that is expanded after it is positioned within the eye. The stent 2405 can be for example a braided or laser cut stent made of stainless steel or Nitinol.

The shunt can also be manufactured of a material that is absorbed into the eye tissue after placement in the eye. Once absorbed, a space remains where the shunt was previously located. In this regard, the shunt can be manufactured of a complex carbohydrate or a collagen that is non-inflammatory. In another embodiment, the shunt is covered with or filled with a material that absorbed into the eye over time such as to prevent hypotony or to prevent a clot forming within the tube.

In the case of biodegradable or bioabsorbable devices, a variety of materials can be used, such as biodegradable polymers including: hydroxyaliphatic carboxylic acids, either homo- or copolymers, such as polylactic acid, polyglycolic acid, polylactic glycolic acid; polysaccharides such as cellulose or cellulose derivatives
5 such as ethyl cellulose, cross-linked or uncross-linked sodium carboxymethyl cellulose, sodium carboxymethylcellulose starch, cellulose ethers, cellulose esters such as cellulose acetate, cellulose acetate phthallate, hydroxypropylmethyl cellulose phthallate and calcium alginate, polypropylene, polybutyrates, polycarbonate, acrylate polymers such as polymethacrylates, polyanhydrides,
10 polyvalerates, polycaprolactones such as poly- ϵ -caprolactone, polydimethylsiloxane, polyamides, polyvinylpyrrolidone, polyvinylalcohol phthallate, waxes such as paraffin wax and white beeswax, natural oils, shellac, zein, or a mixture thereof, as listed in United State Patent 6,331,313 to Wong, which is expressly incorporated by reference in its entirety.

15 Figure 26 shows another embodiment of the shunt that is formed of a sponge-like flow member 2610 that is made of a porous material, such as polyester material. The porous nature of the flow member 2610 forms one or more fluid pathways for the flow of aqueous humour through the flow member. The flow member 2610 can be formed of a material that can be pierced along its length by a
20 wire or other structure. The piercing forms an internal lumen 2710 (Figure 27) through which aqueous humour can flow. The internal lumen 2710 can be formed in the situation where it is desired to increase the flow of aqueous humour through the flow member.

25 Figure 28 shows another embodiment of the shunt 105 that includes a pair of anchor members 3305 located on opposite ends of the shunt. The anchor members 3305 are sized and shaped to engage the eye tissue to retain the shunt 105 in a fixed or substantially fixed position within the eye. The shunt 3305 includes an elongated central region on which are disposed one or more tines or teeth 3310 that are adapted to anchor with the eye. The anchor members 3305 and the teeth 3310

extend outwardly from the shunt 105 to define a space 3315 disposed along at least one side of the shunt 105 when the shunt 105 is positioned in the eye. The teeth can be oriented to extend at least partially into the trabecular meshwork such that the teeth form flow pathways into Schlemm's canal. The teeth 3310 can be
5 manufactured of various materials including silver or coated with silver. Silver is a material that prohibits growth of surrounding tissue such that a space is retained around the shunt.

As discussed above with reference to Figure 7, a distal or proximal end of the shunt 105 can be equipped with retaining structures. Figure 29 shows an end
10 region (distal and/or proximal) of the shunt 105 that includes slices that extend generally along the longitudinal direction of the shunt. The orientation of the slices can vary. For example, the slices can extend longitudinally such that the slices define a plurality of longitudinally-extending teeth that can interact with eye tissue to resist migration of the shunt 105. The slices can also be oriented transverse to the
15 longitudinal axis of the shunt. The end region can be flared outward to provide further resistance to migration.

In another embodiment, shown in Figure 30, one or more sleeves 3405 are positioned over the outer surface of the shunt 105. The sleeves 3405 can be interspersed at various locations along the length of the shunt 105. In the
20 embodiment of Figure 30, a first sleeve 3405 is located on a distal region of the shunt 105 and a second sleeve 3405 is located on a proximal region of the shunt 105. More than two sleeves can be positioned on the shunt. The sleeves 3405 have an inner diameter that permits the sleeves to be fixedly mounted over the shunt. The outer diameter of the sleeve is larger than the outer diameter of the shunt such
25 that the sleeves form a raised surface on the shunt. The sleeves 3405 can be annular such that the sleeves have an internal lumen that fits entirely around the circumference of the shunt. Alternately, the sleeves 3405 are non-annular strips of material that are positioned on the shunt such that they cover only a portion of the circumference of the shunt.

As an alternative or in addition to sleeves that are positioned over the shunt, the outer surface of the shunt can include grooves that are machined or molded into the outer surface. The grooves can be a series of annular grooves or a single corkscrew groove that extends along the length of the shunt. The grooves function to form alternating raised and lowered surfaces on the shunt. The shunt could also include pits or pockmarks on the outer surface.

The sleeves 3405 can have a smooth outer surface, an undulating outer surface, or can include one or more slices that can be oriented at various angles relative to the longitudinal axis of the shunt 105. The slices form teeth in the sleeves 3405 to resist migration of the shunt. The sliced teeth can be biased outward such that the teeth flare outward and engage adjacent tissue to prevent movement in either the proximal or distal direction.

Any of the sleeves can also act as a marker to show the physician the proper shunt length to be inserted into the eye. Alternately, one or more printed markers can be formed on the shunt outer wall or on the delivery device. The markers can be BaSO₄ markers embedded in the shunt material wall wherein the markers are made from an extruded polymer compounded with this radiopaque substance in the region of the desired radiopacity. Further, the markers can be laser printed or etched on the shunt device to show the amount of shunt deployed in the suprachoroidal space, or the amount by which the shunt device should be allowed to protrude into the anterior chamber. The sleeves can be manufactured of various materials. In one embodiment, at least one of the sleeves is made of an anti-microbial silver material.

Figure 31 shows another embodiment of the shunt 105 with sleeves 3605 disposed on proximal and distal ends of the shunt. The sleeves 3605 have slices that form arcs. The slices can be straight or they can be curvilinear. When the slices are located on the sleeves 3605 rather than on the body of the shunt itself, the slices will not interfere with fluid flow through the lumen of the shunt. There is a risk that if the slices are on the shunt itself, an ingrowth of tissue into the slices can

result. Such an ingrowth can interfere with the flow of fluid through the shunt's internal lumen. Advantageously, the sleeves permit the use of slices that do not interfere with the internal lumen of the shunt. The slices on the sleeves create retention means on both ends of the shunt. The slices are biased toward each other
5 so that micromotion of the shunt is prevented. As a force acts upon the shunt to force the shunt either further into the suprachoroidal space or into the anterior chamber, the slices begin to extend axially from the longitudinal axis of the inner lumen causing a restriction of movement of the shunt in either direction.

Figure 32 shows yet another embodiment of the shunt 105. In this
10 embodiment, a retention structure, such as a coil 3705, is located on the outside of the shunt 105. The coil 3705 can be formed of a wire that is wrapped around the outer surface of the shunt. The coil 3705 functions to retain the shunt 105 within the eye. In some embodiments, the coil 3705 can also be sized and shaped such that it forms a conduit or flow path that directs fluid to flow along the outside of the shunt.
15 The retention structure need not be coil shaped but can rather have various shapes and sizes adapted to retain the shunt in place. For example, the retention structure can be a straight wire that extends along the length of the shunt and that is raised relative to the outer surface of the shunt. The wire can have various dimensions. In one embodiment, the wire has a diameter of 0.0005 inch.

20 It can be desirable to position one or more structures on the shunt that can be grasped, such as to reposition the shunt or remove the shunt from the eye. Some embodiments of the shunt that include removal or repositioning structures are now described. The removal or repositioning structure can be any structure on the shunt that can be grasped in order to move or remove the shunt. For example, the
25 removal structure can be an enlarged region, a raised region, or a region of reduced diameter that provides a location that can be grasped by a removal tool. The retention elements described above can also serve as a grasping element for removal or moving of the shunt.

Figure 33A shows an embodiment of the shunt 105 that includes a grasping loop 3805 on the proximal end of the shunt. The grasping loop 3805 is shaped such that it can be grasped by a removal tool or a repositioning tool. The grasping loop 3805 can be connected to a coil member 3810 that extends entirely or partially along the length of the shunt 105 such that when the grasping loop is pulled, the shunt undergoes a radial reduction in size, as shown in Figure 33B. The shunt can also include outer thread structures that permit the shunt to be screwed into the suprachoroidal space by rotating the shunt in one direction and then screwed out by rotating in an opposite direction. The threads can grasp onto the surrounding tissue to provide counter traction when the grasping loop 3805 is pulled. The shunt 105 can also be formed of a braided shaft with a distal grasping loop 3805, as shown in Figure 34.

Figure 35 shows another embodiment of an elongate device 4002 with a snare 4005 located on a proximal end. The device 4002 can be positioned within a lumen of the shunt such that the snare 4005 is compressed within the lumen. In use, the device 4002 is pulled partially out of the lumen such that the snare 4005 expands to form a loop that can be grasped by a removal or repositioning tool.

In another embodiment, shown in Figure 36, the shunt 105 includes a distal region 4105 that is flat and thin so as to have a spatula-like shape. The flat and thin configuration of the shunt is adapted to facilitate penetration of the eye and to facilitate peeling of the choroid from the sclera and positioning of the distal region of the applicator in the suprachoroidal space. The shunt includes an internal lumen for the passage of a guidewire or through which fluid or visco-elastic substance(s) can be passed to assist dissection or visualization. In addition, a fiber optic can also be passed through the lumen to assist direct visualization of the treatment region as desired during placement or repositioning of the shunts.

As discussed, the shunt 105 can be shaped or otherwise configured so as to minimize the risk of trauma to the eye during delivery or during micromotion of the shunt after the shunt has been delivered. For example, any region of the shunt can

have an atraumatic shape or can be manufactured of or coated with a soft material. In one embodiment, shown in Figure 37, an atraumatic tip 4205 is located on the proximal region of the shunt 105. The tip 4205 can be shaped in an atraumatic manner, such as by having a rounded end. The tip 4205 can be manufactured of a material that is softer than the remainder of the shunt or can be manufactured of the same material. The atraumatic tip 4205 is adapted to protect against damage to the cornea in the event of corneal contact or micromotion of the shunt. In one embodiment, at least a portion of the shunt includes a silicone sleeve that at least partially covers the outer surface of the shunt. The silicone sleeve can be formed by dipping the shunt into a silicone solution.

Figure 38 shows another embodiment wherein the shunt 105 includes a resilient region 4305. The resilient region can be formed in various manners. For example, in one embodiment, the resilient region is formed by either a reinforced region of silicone tube or by a separate resilient element such as a spring. In another embodiment, the resilient region 4305 is corrugated to provide flexibility. The spring can be formed of various materials, including polyimide and stainless steel. Any of the embodiments of the shunt described herein can include a resilient region along a portion of its length or can be resilient along its entire length. In addition, the shunt can be flexible along its entire length, can have a predetermined stiffness along its entire length or can have a stiffness that varies along its length.

As discussed above with reference to Figures 22 and 23, the shunt can be formed without an internal lumen and configured such that the flow occurs along the outer surface of the shunt. Figure 39 shows another embodiment of a shunt 105 that does not have an internal lumen. The shunt 105 has a plurality of extensions 4405 that extend radially outward from a central core. The extensions 4405 define elongated grooves that extend along the length of the shunt. The elongated grooves serve as flow pathways to guide fluid flow along the length of the shunt. The embodiment of Figure 39 has four extensions although the quantity of extensions can vary. A material, such as silver, can be positioned or coated within

the grooves to keep the channels open and to provide increased distribution area for fluid flow. As mentioned, silver serves to inhibit or prevent tissue growth.

As shown in Figure 40A, the peripheral edges of the extensions 4405 can have grooves or other structures that are adapted to retain or anchor the shunt within the eye. In the embodiment shown in Figure 40B, the shunt 105 has extensions 4405 and a central core with an internal lumen 4407 that can be used to mount the shunt on a delivery device. The central lumen 4407 can also be used for the flow of fluid through the shunt.

The shunt can include features that are adapted to modify or enhance the flow of fluid through or along the shunt, such as after the shunt has been placed in the eye. In one embodiment, shown in Figure 41, the shunt 105 has one or more holes that 4605 that communicate with the internal lumen. The holes are initially plugged with a material such that flow cannot occur through the holes. After placement of the shunt in the eye, the holes can be unplugged, such as by inserting an instrument through the holes or applying energy to the location where the holes are to be formed. The holes can also unplug automatically by plugging the holes with a material that degrades upon placement in the eye or that degrades after a period of time.

Figure 42A shows a cross-sectional view of a portion of another embodiment of the shunt 105. In this embodiment, the shunt 105 includes a narrowed region 4705 such that the internal lumen 4710 is at least partially blocked in the narrowed region 4705. As shown in Figure 42B, the narrowed region 4705 can be opened or expanded at a desired time, such as through applying heat to the narrowed region 4705 to cause the narrowed region to expand such that the internal lumen is no longer blocked. The region can then be narrowed again by further application of heat if desired. The narrowed region can also be opened and closed by tying a biodegradable band or suture around the narrowed region. The sutures can erode over a time period so that the narrowed region gradually opens over time.

Figure 43 shows another embodiment of the shunt 105 that includes one or more valved regions 4907 along the length of the shunt. The valved regions 4907 serve to regulate the flow of fluid through the internal lumen. Each of the valve regions 4907 can include a separate valve structure or can be shaped to regulate fluid flow. For example, the valved regions can have an expanded size that permits more fluid flow or can have a reduced size that limits fluid flow. The valved regions can be colored so as to respond to different colors of laser light depending on a desired result.

Figure 44 shows an embodiment of the shunt 105 that includes a bulbous element 4905 that is radially larger than the remainder of the shunt. The bulbous element 4905 can be fixed in the enlarged state or it can be adapted to transition from a reduced-size state to the enlarged-size state. For example, the bulbous element 4905 can be an expandable balloon or it can be an expansion members 910 such as was described above in Figure 9A. The bulbous element 4905 can include holes that communicate with the internal lumen of the shunt 105 to permit ingress and egress of fluid.

Figure 45 shows another embodiment of the shunt 105 wherein the bulbous element 4905 is located between the proximal and distal ends of the shunt 105. Thus, the shunt 105 includes a central bulbous element 4905 with proximal and distal regions of reduced radial size relative to the bulbous element. The shunt 105 can also include a plurality of bulbous elements that are interspersed along the length of the shunt.

The use of the shunt 105 with the bulbous element 4905 is now described with reference to Figures 46 and 47, which show two embodiments of the bulbous element shunt positioned in the suprachoroidal space SS. As shown in Figures 46 and 47, the shunt 105 is positioned such that a proximal end communicates with the anterior chamber AC and the bulbous element 4905 is positioned in the suprachoroidal space. The enlarged bulbous region 4905 forms a space or "lake" for accumulation of fluid within the suprachoroidal space. Because the lake is

contained entirely within the suprachoroidal space and enclosed by tissue, the lake is not prone to infection and other complications. The lake can also be formed using an embodiment of the shunt that does not have a bulbous element. A fluid can be flowed into the suprachoroidal space through the internal lumen of the shunt. The fluid fills and accumulates within the suprachoroidal space to form the lake.

In another embodiment, the lake is formed via hydro-dissection. A delivery cannula can be positioned in the eye such that fluid can be flowed into the suprachoroidal space via the cannula. The fluid is flowed into the eye with a pressure sufficient to form a dissection plane within the suprachoroidal space. The fluid can then accumulate within the suprachoroidal space so as to form a lake.

Figure 48 shows an embodiment of the shunt 105 that includes a distal tip member 5305 that is integrally formed with the shunt. The tip member 5305 has a shape that is adapted to facilitate dissection into the suprachoroidal space. For example, the tip member 5305 can be "bullet" shaped in that the diameter of the tip member 5305 gradually reduces moving along the distal direction. The tip member 5305 can include one or more holes that communicate with the internal lumen of the shunt. Alternately, the tip member 5305 can be without holes and holes can be placed on the side of the shunt 105. The tip member 5305 can be manufactured of various materials, including stainless steel.

Figure 49 shows an embodiment of a shunt 105 that mounts over a mandrel 5405, which can be a portion of the applicator 525 such that the mandrel 5405 can be incorporated into the delivery system. The shunt 105 is adapted to conform to the shape of the mandrel 5405 when it is mounted on the mandrel, such as during delivery of the shunt 105. When the mandrel 5405 is removed, the shunt 105 transitions to a different shape. The shunt 105 can be at least partially manufactured of a shape-memory material to accomplish the change in shape. In one embodiment, one or more Nitinol rings are disposed on the shunt wherein the rings undergo a shape change to induce the shunt to transition in shape. A Nitinol wire can also be threaded along the length of the shunt to induce the shape change.

Different regions of the shunt 105 can transition to different shapes. For example, the shunt 105 can include a proximal region 5410 that is substantially round when the mandrel 5405 is positioned within the shunt. When the mandrel 5405 is removed from the shunt, the proximal region 5410 radially reduces in size while the remainder of the shunt remains the same shape, as shown in Figure 50. The proximal region 5410 can taper in size when the mandrel is removed such as to limit or meter flow through the shunt. In addition, the proximal tip of the shunt can flatten to an oval shape while the remainder of the shunt remains round. Alternately, the proximal tip can remain round but of a reduce diameter relative to the remainder of the shunt.

When the mandrel is removed, the shunt 105 can transition to a shape that is particularly suited for placement and delivery into the suprachoroidal space. For example, with reference to Figure 51A, the shunt 105 can include a first region 5605 that transitions to a first contour or first radius of curvature and a second region that transitions to a second contour or second radius of curvature. Figure 52 shows the shunt of Figure 51 positioned in the eye. The first region 5605 has a first radius curvature that complements the radius of curvature of the suprachoroidal space. The second region 5610 has a second radius of curvature that is tighter than the first radius such that the proximal tip of the shunt is directed away from the cornea C and toward the anterior chamber AC. This reduces the likelihood that the proximal tip of the shunt 105 will contact the cornea after placement of the shunt.

Figure 51B shows another embodiment of a shunt 105 that has a staple shape. The shunt 105 includes a pair of legs 5615a and 5615b that are connected by a connecting member 5620. In an embodiment, both of the legs 5610 have an internal lumen with a distal opening 5625 for inflow or outflow of fluid. The legs 5615 also have one or more proximal openings. The proximal openings can be located at the location where the legs connect to the connecting member 5620. Alternately, the connecting member 5620 can also have an internal lumen that communicates with the internal lumens of the legs 5615. The connecting member

5620 can include one or more openings that communicate with the internal lumens for inflow or outflow of fluid. In another embodiment, only one of the legs 5615 has an internal lumen while the other leg is solid and serves as an anchoring member.

In use, the shunt 105 of Figure 51B is positioned in the eye such that the
5 distal opening 5625 of each leg 5615 communicates with the suprachoroidal space and the connecting member is positioned is located in the angle between the iris and the cornea. One or both of the legs 5615 provides a fluid passageway between the suprachoroidal space and the anterior chamber. If one of the legs 5615 does not include an internal lumen, then the non-lumen leg can serve as an anchor that
10 secures the shunt 105 in a fixed position in the eye.

Figure 51C shows another embodiment of a shunt 105. This embodiment includes a partially-annular connecting member 5640 and a plurality of legs 5645. The connecting member 5640 is partially annular in that it extends over a range of less than 360 degrees. For example, the connecting member 5640 can extend from
15 about twenty degrees to greater than 180 degrees. The connecting member 5640 and the legs 5645 collectively reside within a curved plane that conforms to the curvature of a dissection plane that includes the suprachoroidal space. One or more of the legs 5645 can include an internal lumen that communicates with an inflow and outflow openings. In use, the shunt 105 of Figure 51C is positioned in
20 the eye such that the connecting member 5640 sits within the angle between the iris and the cornea, while the legs 5645 extend into the suprachoroidal space. The legs 5645 can serve as fluid conduits and/or as anchors for securing the device in the eye.

Further Description Of Methods

25 There are various pathways of approach for delivering the shunt into the eye using the delivery system such as the system shown in Figure 6B. Figure 53 shows a schematic, front view of the upper region of a patient's face including the two eyes. For reference purposes, the eyes are shown divided into four quadrants I, II, III, and IV when viewed from the front of the eye. For each eye, the quadrants I and

III are located on the lateral side of the eye and the quadrants II and IV are located on the medial side of the eye. In one embodiment, the approach pathway passes through only a single quadrant. In other embodiments, the pathway passes through at least two quadrants, at least three quadrants, or through all four quadrants. In an exemplary shunt delivery embodiment, the surgeon delivers the shunt with the shunt initially approaching the eye from quadrant I or IV such that the corneal incision is within quadrant I or IV. In another shunt delivery embodiment, the shunt approaches the eye from quadrant II or III. As described below, the location where the shunt is implanted in the suprachoroidal space can be at various locations relative to the location of the incision. In an embodiment, the location where the shunt is implanted in the suprachoroidal space is from 0 degrees to 180 degrees from the incision location. For example, the incision can be in quadrant I and the implant location is 180 degrees away in quadrant III. In another embodiment, the incision location and implant location are separated by at least 90 degrees or up to 90 degrees. The actual placement of the shunt can be in any quadrant depending on the shape of the tip of the applier.

Figures 54A and 54B shows perspective and plan views, respectively, of an exemplary delivery pathway 5701 of the applier and shunt during implantation of the shunt into the eye. The delivery pathway 5701 begins at an incision location 5702 and moves toward dissection location 5703 where the shunt dissects the scleral spur and approaches the suprachoroidal space.

In one embodiment, the incision location 5702 is along the axis that separates quadrants I and IV (i.e., at the "9 o'clock" or "3 o'clock" position of the eye) and the dissection location 5703 is approximately 90 degrees from the incision location (i.e., at the "12 o'clock" position of the eye). Such a delivery pathway is transcorneal in that it traverses over the cornea. However, the delivery pathway need not be transcorneal. Figures 55A-55D show the delivery system and attached shunt traveling along the previously described delivery pathway. In Figure 55A

(front plan view) and Figure 55B (perspective view), the delivery system 515 is in an initial approach position relative to the eye such that the distal end of the applier 525 is at the incision and about to penetrate into the eye. If the applier 525 is curved, the line of curvature of the applier 525 can be in various orientations. In one embodiment, the applier's line of curvature is initially oriented such that the curvature moves away from the interior of the eye.

With reference now to Figure 55C (front plant view) and Figure 55D (perspective view), the applier and shunt have passed over the cornea such that the distal tip of the applier has passed through the anterior chamber and is at or near the scleral spur. During such passage, the handle of the delivery system is rotated and translated to align the applier's curvature with the curvature of the suprachoroidal space. The tip of the applier 525 is then advanced and passed through the scleral spur to position the shunt 105 within the suprachoroidal space.

Figure 56 shows an alternative transcorneal delivery pathway 5701 wherein the incision location 5702 and the dissection location 5703 are approximately 180 degrees from one another. Figures 55A, 55B, and 57 show the delivery system and attached shunt traveling along such a delivery pathway. In the initial approach orientation, the delivery system 510 is positioned such that the tip of the applier 525 is at the incision location (such as shown above in Figures 55A and 55B). The handle component 515 is translated and/or also rotated such as approximately ninety degrees so that the distal tip of the applier 525 resides within a plane that intersects the scleral spur. The line of curvature of the applier 525 is not yet necessarily aligned with the curvature of the eye in quadrant I. In addition, the applier is still positioned at or near quadrant I.

With reference now to Figure 57, the delivery system 510 is translated such that the distal tip of the applier 525 moves near or into quadrant IV. The translation can occur either by translating the handle component 510 or by causing the advancing member 530 and applier 525 to elongate. In conjunction with the translation, the handle component 510 is rotated to re-orient the applier 525 such

that the line of curvature substantially aligns with the curvature of the eye, specifically the curvature of the dissection plane, which extends through the suprachoroidal space. At this stage, the tip of the applier is directed toward the scleral spur and the line of curvature extends toward the suprachoroidal space. The
5 applier 525 can then be distally advanced into the suprachoroidal space and the shunt dismounted from the applier so as to place the shunt in or near quadrant IV.

As mentioned, the delivery system 510 can approach the eye in other manners than described above. In another embodiment, the incision location and the dissection location are within the same quadrant. In such an embodiment, the
10 distal tip of the applier passes through an incision in the cornea that is closer to the scleral spur, rather than from across the eye as in the previously-described embodiments. Figures 58A-58D show an example of such a delivery pathway. In Figure 58A (plan view) and Figure 58B (perspective view), the delivery system 510 in an initial approach position (such as in quadrant I). The line of curvature of the
15 applier 525 is not yet aligned with the curvature of the eye. The delivery system is translated so that the applier 525 penetrates the eye. The handle component 510 is then rotated such that the applier is directed toward the scleral spur and the line of curvature extends toward the suprachoroidal space, as shown in Figure 58C (plan view) and Figure 58D (perspective view). The applier 525 can then be distally
20 advanced through the scleral spur and into the suprachoroidal space. The whole procedure occurred with the applier being positioned in a single quadrant. The delivery system 510 can be used to approach the eye from various approach angles so as to position multiple shunts 105 around the circumference of the eye, as shown in Figure 58D. The shunts 105 can be interspersed or grouped in clusters around
25 the entire circumference or a portion of the circumference of the eye.

A further embodiment is one where multiple shunts are loaded into a delivery system and able to be delivered into various locations around the anterior chamber to the suprachoroidal space in a fashion such that the delivery device is not removed from the anterior chamber. The device is moved throughout the anterior

chamber and has a multi-fire chamber such that as one shunt is delivered from the applicator 525, another shunt is loaded onto the applicator 525 and so on. This allows multiple shunt placements without reloading or using another device.

Infusion

5 During the procedure, fluid can be infused into the eye in order to stabilize the pressure in the anterior chamber, such as prior to, during, or after installation of a shunt. Infusion can also be used to maintain a clear field of view along the delivery pathway during delivery of the shunt. There is a risk that the pressure within the anterior chamber can adversely drop due to loss of fluid, which can possibly result in
10 collapse of the anterior chamber. In order to counter a drop in pressure, fluid can be infused into the anterior chamber in order to maintain the pressure within a desired range. The fluid can be infused through a dedicated internal lumen in the applicator or infused through the lumen in the shunt. The fluid can also be infused through a separate system that interfaces with the eye. For example, a cannulized member
15 can be inserted into the anterior chamber and coupled to a source of fluid, such as a bag or saline or other biocompatible fluid source. If the pressure within the anterior chamber drops below a threshold value, the resulting pressure differential can cause fluid to automatically flow into the anterior chamber through the cannulized member.

 A dye can be infused into the eye in order to provide visualization. The dye
20 can be viewable through a visualization instrument. As the dye flows into the suprachoroidal space, it provides a visualization of flow. The dye can be photoactivated such that it shows aqueous humor dispersion when a certain type of light is applied to the dye. In addition, an ultrasound or Doppler can be used (such as by integrating a Doppler tip on the delivery device) to visualize or sense flow, or
25 the rate of flow, through the suprachoroidal space.

Shunts in Use with Closed Angle Glaucoma

 With reference to Figure 59, it is possible for aqueous humor to accumulate within the posterior chamber PC such that at least a portion of the iris I is forced upward into the anterior chamber. Due to the pressure in the posterior chamber, the

iris can angle toward the cornea so as to form a crest and then fall back toward the posterior chamber. In such a case, the base of the iris might interfere with or block the opening on the proximal end of the shunt. A shunt 105 can be used having an elongated length or extension 6205 that repositions the proximal end of the shunt 5 105 to a location that is not blocked or interfered with by the iris. For example, as shown in Figure 59, the extension 6205 is sized and positioned such that a proximal end 6210 is positioned over the crest of the iris. The extension 6210 can be made of a soft or flexible material so as to minimize or eliminate the risk of damage to the cornea should the proximal end 6210 contact the cornea. In another embodiment, 10 shown in Figure 60, the extension 6205 has a curved shape such that the distal end 6210 is angled away from the cornea.

Figure 61 shows another embodiment wherein the shunt extends through the iris I such that the proximal end 6210 and the internal lumen of the shunt communicate with the posterior chamber. The shunt permits aqueous humor to flow 15 out of the posterior chamber to release pressure in the posterior chamber. The shunt 6205 can extend through various locations of the iris and can be manufactured of a material that is compliant, such as silicone. The embodiment shown in Figure 61 can be used in place of or in conjunction with an iris iridoplasty procedure. In addition, the delivery system can be adapted such that a distal end of 20 the applicator has a tip; such as an RF tip as described in more detail above, that is adapted to perform an iridoplasty without the use of the shunt.

Trans-Scleral Delivery of Shunt

In the previously-described embodiments, the shunt 105 is delivered by passing the shunt through a corneal incision or puncture. The surgeon then passes 25 the shunt through the anterior chamber, across the scleral spur, and into the suprachoroidal space. In another embodiment, the surgeon makes an incision in the sclera to provide a trans-scleral delivery of the shunt into the eye. After making the scleral incision, the surgeon passes the proximal end of the shunt through the scleral incision into the sclera into suprachoroidal space. The surgeon then pushes the

shunt toward the anterior chamber, such as via the scleral spur, until the proximal region of the shunt is positioned in the anterior chamber and the distal region of the shunt is positioned in the suprachoroidal space.

The trans-scleral approach is described in more detail with reference to
5 Figures 62 and 63. Figure 62 shows the delivery device 510 positioned such that the distal tip of the applier 525 or the shunt 105 itself can penetrate through an incision in the sclera. The applier 525 or shunt 105 can be used to make the incision or a separate cutting device can be used.

After the incision is formed, the applier 525 and attached shunt advances
10 through the sclera and into the suprachoroidal space. The surgeon advances the applier 525 until a proximal region of shunt 105 is positioned within the anterior chamber and a distal region is within the suprachoroidal space, as shown in Figure 63. The surgeon then releases the shunt 105 off of the applier 5252 so that the shunt provides a fluid passageway between the anterior chamber and the
15 suprachoroidal space. In one embodiment, the applier 525 travels along a pathway from the suprachoroidal space toward the scleral spur such that the applier crosses through the scleral spur on the way to the anterior chamber. The applier 525 can be pre-shaped, steerable, articulating, or shapeable in a manner that facilitates the applier passing through the suprachoroidal space along a proper angle or pathway.

As discussed above, various devices can be used to assist in guiding the
20 delivery device and shunt into a proper position in the eye. For example, a guidewire can be used to guide the applier or the shunt over the guidewire to the proper location in the eye. The guidewire or the delivery can be equipped with a fiber optic that provides direct visualization of the eye during delivery of the shunt. In
25 another embodiment, one or more imaging systems can be used during deliver of the device. Such imaging systems can include, for example, ultrasound (UBM), optical coherence tomography (OCT), and endoscopic viewing. OCT performs cross-sectional imaging of internal tissue microstructure by measuring the echo time delay of backscattered infrared light using an interferometer and a low coherence

light source. For example, the Visante® OCT system from Zeiss Medical (Germany) can be used to non-invasively image during placement of the implants, or to confirm placement once the shunt has been placed, post procedure and also at follow up. In addition, certain ultrasonic systems and those providing enhanced tactile feedback or ultrasonic guidance can be used, for example devices shown in US patent 5 6969384 and 6676607, incorporated by reference herein in their entirety, Endoscopes, such as the i-Scope™, and UBM devices (high frequency ultrasound) can be used such as those made by Ophthalmic Technologies, Inc. (Ontario, Canada).

10 In another embodiment, the shunt is deployed into the eye in combination with a cataract treatment procedure. In a cataract treatment procedure, the surgeon makes an incision in the cornea and inserts a viscoelastic material into the eye through the incision. The surgeon then removes the cataract through the incision. In combination with such a procedure, the surgeon implants a shunt 105 into the 15 eye in the manner described above. A new lens can be implanted into the eye pursuant to this procedure. The shunt can be implanted either before or after removal of the lens.

Although embodiments of various methods and devices are described herein in detail with reference to certain versions, it should be appreciated that other 20 versions, embodiments, methods of use, and combinations thereof are also possible. Therefore the spirit and scope of the appended claims should not be limited to the description of the embodiments contained herein.

What is claimed:

1. A method of implanting an ocular device into the eye, comprising:
forming an incision in the cornea of the eye;
5 inserting a shunt through the incision into the anterior chamber of the eye
wherein the shunt includes a fluid passageway;
passing the shunt along a pathway from the anterior chamber through the
scleral spur of the eye into the suprachoroidal space; and
positioning the shunt in a first position such that a first portion of the fluid
10 passageway communicates with the anterior chamber and a second portion of the
fluid passageway communicates with the suprachoroidal space to provide a fluid
passageway between the suprachoroidal space and the anterior chamber.
2. A method as in claim 1, further comprising mounting the shunt on a
15 delivery device and inserting the shunt through the incision while the shunt is
mounted on the delivery device.
3. A method as in claim 2, wherein the shunt is mounted on a needle of
the delivery device.
20
4. A method as in claim 2, further comprising pushing the shunt off the
delivery device into the first position.
5. A method as in claim 2, further comprising:
25 positioning the shunt in the first position while the shunt is mounted on the
delivery device; and
withdrawing the delivery device from the shunt while the shunt stays in the
first position.

6. A method as in claim 2, wherein a portion of the delivery device forms the incision by puncturing the cornea.

7. A method as in claim 1, wherein a distal end of the shunt forms the
5 incision by puncturing the cornea.

8. A method as in claim 1, further comprising advancing the shunt across the iris prior to passing the shunt through the scleral spur.

9. A method as in claim 1, further comprising using a guidewire to guide
10 the shunt along the pathway.

10. A method as in claim 1, further comprising using a cannula to guide
the shunt along the pathway.

15

11. A method as in claim 1, wherein the shunt has a curvature and further comprising positioning a distal end of the shunt at the scleral spur such that the curvature points toward the suprachoroidal space.

20

12. A method as in claim 1, wherein when in the first position at least 2 millimeters of the shunt is located in the anterior chamber.

13. A method as in claim 1, further comprising passing the shunt through the ciliary body.

25

14. A method as in claim 1, further comprising passing the shunt along the pathway through the ciliary body until a decrease in resistance to passage is sensed.

15. A method as in claim 1, wherein a distal end of the shunt has a spade shape, and further comprising creating a dissection plane in the tissue plane between the choroid and the sclera using the distal end of the shunt.

5 16. A method as in claim 1, further comprising using ultrasonic visualization while passing the shunt along the pathway.

10 17. A method as in claim 1, wherein the shunt includes a skirt that is located in the anterior chamber when the shunt is in the first position such that the skirt inhibits the shunt from passing further into the suprachoroidal space.

15 18. A method as in claim 1, further comprising positioning multiple shunts in the eye wherein each of the multiple shunts provide a fluid passageway between the suprachoroidal space and the anterior chamber.

19. A method as in claim 18, wherein the multiple shunts are located end-to-end in the eye such that the multiple shunts collectively provide a single fluid passageway between the suprachoroidal space and the anterior chamber.

20 20. A method as in claim 18, wherein the multiple shunts are interspersed in the eye such that each of the multiple shunts provides a separate fluid passageway between the suprachoroidal space and the anterior chamber.

25 21. A method as in claim 1, wherein a distal end of the shunt is passed through the incision followed by a proximal end of the shunt.

22. A method as in claim 1, wherein the incision is formed in the limbus of the cornea.

23. A method as in claim 22, wherein the incision is about 1 mm in size.

24. A method as in claim 22, wherein the incision is no greater than about 2.85 mm in size

5

25. A method as in claim 22, wherein the incision is no greater than about 2.85 mm and is greater than about 1.5 mm in size.

10 26. A method as in claim 1, wherein the shunt is in a state of reduced size during passage along the pathway and wherein the shunt transitions to an enlarged size when the shunt is in the first position.

27. A method as in claim 1, wherein the shunt is attached to an endoscope during passage along the pathway.

15

28. A method as in claim 27, wherein the endoscope is mounted to the side of the shunt.

20 29. A method as in claim 27, wherein the endoscope is co-axially positioned with the shunt.

30. A method as in claim 1, further comprising using a gonioscopy lens during delivery of the shunt into the eye.

25 31. A method as in claim 1, wherein the fluid passageway is an internal lumen in the shunt.

32. A method as in claim 1, wherein the fluid passageway is along an external surface of the shunt.

33. A method as in claim 1, wherein fluid flows through the fluid passageway via capillary action.

5 34. A method as in claim 1, forming a passageway through the eye along the pathway and inserting the shunt into the eye after formation of the passageway.

35. A method as in claim 1, wherein passing the shunt along a pathway from the anterior chamber through the scleral spur of the eye comprises puncturing
10 the scleral spur.

36. A method as in claim 1, wherein the shunt is positioned in the eye approximately 90 degrees from the location of the incision.

15 37. A method as in claim 1, wherein the shunt is positioned in the eye approximately 90 degrees to approximately 180 degrees from the location of the incision.

38. A method as in claim 1, wherein the shunt includes a marker for
20 placement of the shunt, and further comprising inserting the shunt into the suprachoroidal space until the marker is aligned with a relevant anatomic structure.

39. A method as in claim 38, wherein the anatomic structure is the trabecular meshwork or the scleral spur.

25

40. A method as in claim 38, wherein the shunt includes an echogenic marker, and further comprising using ultrasound to signal the placement of the echogenic marker within the suprachoroidal space.

41. A method as in claim 1, further comprising using an imaging system while passing the shunt along the pathway to assist in positioning the shunt in the first position.

5 42. A method as in claim 41, wherein the imaging system comprises at least one of ultrasound, optical coherence tomography, and endoscopic viewing.

43. A method as in claim 1, further comprising mounting the shunt on a delivery device wherein at least a portion of the delivery device transmits energy
10 from the energy source to facilitate entry of the into the suprachoroidal space

44. A method as in claim 43, wherein only a distal tip of the delivery device transmits energy.

15 45. A method as in claim 43, wherein the energy is RF energy, laser energy, resistive heat energy or ultrasonic energy.

46. A method of implanting an ocular device into the eye, comprising:
forming an incision in the cornea of the eye;
20 inserting a shunt through the incision into the anterior chamber of the eye wherein at least a portion of the shunt can be opened to permit fluid flow along the shunt;
passing the shunt along a pathway from the anterior chamber through the scleral spur of the eye into the suprachoroidal space; and
25 positioning the shunt in a first position such that a first portion of the shunt communicates with the anterior chamber and a second portion of the shunt communicates with the suprachoroidal space; and
opening the shunt to permit fluid flow so that the shunt provides a fluid passageway between the suprachoroidal space and the anterior chamber.

47. A method as in claim 46, wherein the shunt is opened by applying at least one of photochemical energy, laser energy, radiofrequency energy, ultrasound, and heat to the shunt.

5

48. A method as in claim 46, wherein the shunt is opened by uncovering a hole in the shunt.

10

49. A method as in claim 46, wherein the shunt is opened by inserting a needle through the shunt.

50. A method as in claim 46, wherein the shunt is opened after the shunt is in the first position.

15

51. A method as in claim 46, further comprising infusing fluid into the eye during delivery of the shunt into the eye.

52. A method as in claim 46, further comprising infusing a dye into the eye to provide visualization of the pathway.

20

53. A method of implanting an ocular device into the eye, comprising:
forming an incision in the cornea of the eye;
mounting a shunt on a delivery device wherein at least a portion of the shunt or the delivery device has a curvature that matches a curvature of the eye,
inserting the shunt through the incision into the anterior chamber of the eye
wherein the shunt includes a fluid passageway;
aiming the shunt relative to the suprachoroidal space such that the curvature of the shunt or the delivery device aligns with the curvature of the eye; and

25

inserting at least a portion of the shunt into the suprachoroidal space to provide a fluid passageway between the suprachoroidal space and the anterior chamber.

5 54. A method as in claim 53, further comprising passing the shunt through the scleral spur.

 55. A method as in claim 54, wherein passing the shunt through the scleral spur comprises puncturing the scleral spur.

10

 56. A method as in claim 54, wherein passing the shunt through the scleral spur comprises slicing through the scleral spur.

 57. A method as in claim 53, wherein the incision is formed in a first
15 location in the eye and wherein the shunt is inserted in the suprachoroidal space 90 degrees away from the first location.

 58. A method as in claim 53, further comprising approaching the eye with the delivery device from a lateral side of the eye and inserting the shunt into the
20 suprachoroidal space in a medial side of the eye.

 59. A method as in claim 53, wherein the incision is in a first quadrant of the eye and the shunt is inserted into the suprachoroidal space in a different quadrant of the eye.

25

 60. A method of implanting an ocular device into the eye, comprising:
forming an incision in the cornea of the eye;
inserting a shunt through the incision into the anterior chamber of the eye
wherein the shunt includes a fluid passageway;

passing the shunt along a pathway from the anterior chamber through the scleral spur of the eye into the suprachoroidal space; and

5 positioning the shunt in a first position such that a first portion of the fluid passageway communicates with the anterior chamber and a second portion of the fluid passageway communicates with the suprachoroidal space to provide a fluid passageway between the suprachoroidal space and the anterior chamber wherein the shunt is pre-shaped to position the first portion away from the iris.

10 61. A method as in claim 60, wherein the incision is formed in the limbus of the cornea.

62. A method as in claim 60, wherein the incision is about 1 mm in size.

15 63. A method as in claim 60, wherein the incision is no greater than about 2.85 mm in size

64. A method as in claim 60, wherein the incision is no greater than about 2.85 mm and is greater than about 1.5 mm in size.

20 65. A method of implanting an ocular device into the eye, comprising:
forming an incision in the sclera of the eye;
inserting a shunt through the incision into the suprachoroidal space of the eye wherein the shunt includes a fluid passageway;
25 passing the shunt along a pathway from the suprachoroidal space through the scleral spur of the eye into the anterior chamber; and
positioning the shunt in a first position such that a first portion of the fluid passageway communicates with the anterior chamber and a second portion of the fluid passageway communicates with the suprachoroidal space to provide a fluid passageway between the suprachoroidal space and the anterior chamber.

66. A method as in claim 65, wherein passing the shunt through the scleral spur comprises puncturing the scleral spur.

5 67. A method as in claim 65, wherein the shunt includes a marker for placement of the shunt, and further comprising inserting the shunt into the suprachoroidal space until the marker is aligned with a relevant anatomic structure.

10 68. A method as in claim 67, wherein the anatomic structure is the trabecular meshwork or the scleral spur.

15 69. A method as in claim 65, wherein the shunt includes an echogenic marker, and further comprising using ultrasound to signal the placement of the echogenic marker within the suprachoroidal space.

70. A method as in claim 65, further comprising using an imaging system while passing the shunt along the pathway to assist in positioning the shunt in the first position.

20 71. A method as in claim 70, wherein the imaging system comprises at least one of ultrasound, optical coherence tomography, and endoscopic viewing.

25 72. A method as in claim 65, further comprising mounting the shunt on a delivery device wherein at least a portion of the delivery device transmits energy from the energy source to facilitate entry of the into the suprachoroidal space.

73. A method as in claim 72, wherein the energy is RF energy, laser energy, resistive heat energy or ultrasonic energy.

74. A glaucoma treatment device, comprising:
an elongate member having a flow pathway, at least one inflow port
communicating with the flow pathway, and an outflow port communicating with the
flow pathway, wherein the elongate member is adapted to be positioned in the eye
such that the inflow port communicates with the anterior chamber, the outflow port
communicates with the suprachoroidal space, and at least a portion of the elongate
member passes through the scleral spur to provide a fluid pathway between the
anterior chamber and the suprachoroidal space when the elongate member is
implanted in the eye.

10

75. A device as in claim 74, wherein the flow pathway is an internal lumen
in the elongate member.

15

76. A device as in claim 75, wherein the elongate member has an inner
diameter of about 0.012 inch and an outer diameter of about 0.015 inch.

77. A device as in claim 74, wherein at least a portion of the elongate
member has a radius of curvature of at least about 12 mm.

20

78. A device as in claim 74, wherein the elongate member has a length in
the range of about 0.250 inch to about 0.300 inch.

25

79. A device as in claim 74, further comprising at least one anchor
member disposed on the elongate member, the anchor member adapted to anchor
into eye tissue.

80. A device as in claim 74, wherein the anchor member comprises at
least one of a protrusion, wing, tine, or prong.

81. A device as in claim 74, wherein the anchor member transitions between an retracted state of reduced size and an expanded state of enlarged size.

5 82. A device as in claim 74, wherein the elongate member is a wick and wherein the flow pathway is a capillary flow pathway.

83. A device as in claim 74, wherein the elongate member is tubular.

10 84. A device as in claim 74, wherein the elongate member has a tubular portion and a wick portion.

85. A device as in claim 74, further comprising at least one slot in the elongate member.

15 86. A device as in claim 85, wherein at least one slot is an outflow port or an inflow port.

87. A device as in claim 74, further comprising a sleeve positioned on the elongate member.

20

88. A device as in claim 87, further comprising at least one slot in the sleeve.

25 89. A device as in claim 88, wherein the slot extends through the sleeve and through the elongate member.

90. A device as in claim 74, wherein a distal end of the shunt has an atraumatic shape.

91. A device as in claim 74, wherein at least a portion of the shunt is flexible.

5 92. A device as in claim 74, wherein a distal end of the shunt is sharpened.

93. A device as in claim 74, further comprising a skirt located on the shunt.

10 94. A device as in claim 93, wherein the skirt has at least one prong adapted to anchor into eye tissue.

95. A device as in claim 93, wherein the flow pathway is on an external surface of the elongate member.

15 96. A device as in claim 74, wherein the flow pathway is straight.

97. A device as in claim 74, wherein the flow pathway is helical.

20 98. A device as in claim 74, wherein the elongate member includes a bulbous region.

99. A device as in claim 74, wherein the bulbous region is on a tip of the elongate member.

25 100. A device as in claim 74 wherein the elongate member includes at least one slice.

101. A device as in claim 100, wherein the slice extends generally along a longitudinal axis of the shunt to define a plurality of longitudinally-extending teeth.

102. A device as in claim 100, wherein the slice is oriented transverse to a longitudinal axis of the shunt.

5 103. A device as in claim 74, wherein the elongate member include a skirt.

104. A device as in claim 74, wherein the elongate member comprises a stent.

10 105. A device as in claim 74, wherein the shunt includes a marker for placement of the shunt, the marker being a visual, tomographic, echogenic, or radiopaque marker.

15 106. A device as in claim 74, wherein the elongate member is coated on an inner or outer surface with at least one material that maintains the patency of a lumen between the suprachoroidal space and the anterior chamber.

20 107. A device as in claim 74, wherein the elongate member is coated on an inner or outer surface with at least one material that encourages in-growth of tissue to assist with retention of the shunt within the eye.

108. A device as in claim 74, wherein the elongate member is coated on an inner or outer surface with a therapeutic agent.

25 109. A device as in claim 108, wherein the therapeutic agent is a steroid, an antibiotic, an anti-inflammatory agent, an anticoagulant, an antiglaucomatous, an anti proliferative, or a combination thereof.

110. A device as in claim 74, wherein elongate member is coated with a material that expands outward once the elongate member has been placed in the eye.

5 111. A device as in claim 74, wherein elongate member is coated with a material that promotes healing of the shunt into surrounding eye tissue.

112. A device as in claim 74, wherein elongate member is coated with a material that facilitates fluid flow.

10

113. A device as in claim 112, wherein the material is silver.

114. A glaucoma treatment device, comprising:

an elongate member having a flow pathway, at least one inflow port
15 communicating with the flow pathway, and an outflow port communicating with the flow pathway, wherein the elongate member is adapted to be positioned in the eye such that the inflow port communicates with the anterior chamber and the outflow port communicates with the suprachoroidal space, wherein at least a portion of the elongate member includes an enlarged bulbous region adapted to form a space
20 within the suprachoroidal space for accumulation of fluid within the suprachoroidal space.

115. A device as in claim 114, wherein the bulbous region is on a tip of the elongate member.

25

116. A device as in claim 114, wherein the elongate member has an internal lumen.

117. A device as in claim 115, wherein at least one hole in the bulbous region communicates with the internal lumen.

118. A device as in claim 115, wherein the bulbous region is adapted to
5 transition from a reduced size to an enlarged size.

119. A glaucoma treatment device, comprising:
an elongate member having a flow pathway, at least one inflow port
communicating with the flow pathway, and an outflow port communicating with the
10 flow pathway, wherein the elongate member is adapted to be positioned in the eye
such that the inflow port communicates with the anterior chamber and the outflow
port communicates with the suprachoroidal space, the elongate member having a
first region and a second region, wherein the second region is adapted to transition
from a first shape to a second shape while the first regions remains unchanged.

15

120. A device as in claim 119, wherein the second region is a distal region
of the elongate member.

121. A device as in claim 119, wherein the second region transitions to a
20 second shape of reduced radial size relative to the first shape.

122. A device as in claim 119, wherein the second region transitions to a
second shape having a different radius of curvature relative to a radius of curvature
of the first shape.

25

123. A device as in claim 120, wherein the elongate member is at least
partially manufactured of a shape-memory material.

124. A device as in claim 121, wherein at least a portion of the device is manufactured of Nitinol to facilitate the shape change.

5 125. A device as in claim 121, wherein the second region transitions to a second shape that is tapered relative to the first shape, wherein the tapered shape produces a change in fluid flow characteristics for the elongate body.

126. A glaucoma treatment device, comprising:
a curved member sized to fit within an angle between the cornea and the iris
10 of an eye;
at least two legs extending outwardly from the curved member and shaped to extend into the suprachoroidal space, wherein at least one of the legs provides a fluid flow pathway into the suprachoroidal space.

15 127. A device as in claim 126, wherein the curved member over a range of up to 180 degrees.

128. A device as in claim 126, wherein the legs have a curvature that conforms to a curvature of the suprachoroidal space.

20 129. A device as in claim 126, wherein at least one of the leg has an internal lumen that provides a fluid flow passageway between the suprachoroidal space and the anterior chamber of the eye.

25 130. A glaucoma treatment system, comprising:
an elongate member having a flow pathway, at least one inflow port communicating with the flow pathway, and an outflow port communicating with the flow pathway, wherein the elongate member is adapted to be positioned in the eye such that the inflow port communicates with the anterior chamber and the outflow

port communicates with the suprachoroidal space, wherein at least a portion of the elongate member includes an enlarged bulbous region adapted to form a space within the suprachoroidal space for accumulation of fluid within the suprachoroidal space;

5 a delivery device having an elongate applier that removably attaches to the elongate member, the delivery device including an actuator that removes the elongate member from the applier.

10 131. A system as in claim 130, wherein the applier has a sharpened distal tip.

132. A system as in claim 130, wherein the applier attaches within an internal lumen of the elongate member.

15 133. A system as in claim 130, wherein the applier attaches over the elongate member.

20 134. A system as in claim 130, wherein the applier has a curvature that matches the curvature of the suprachoroidal space.

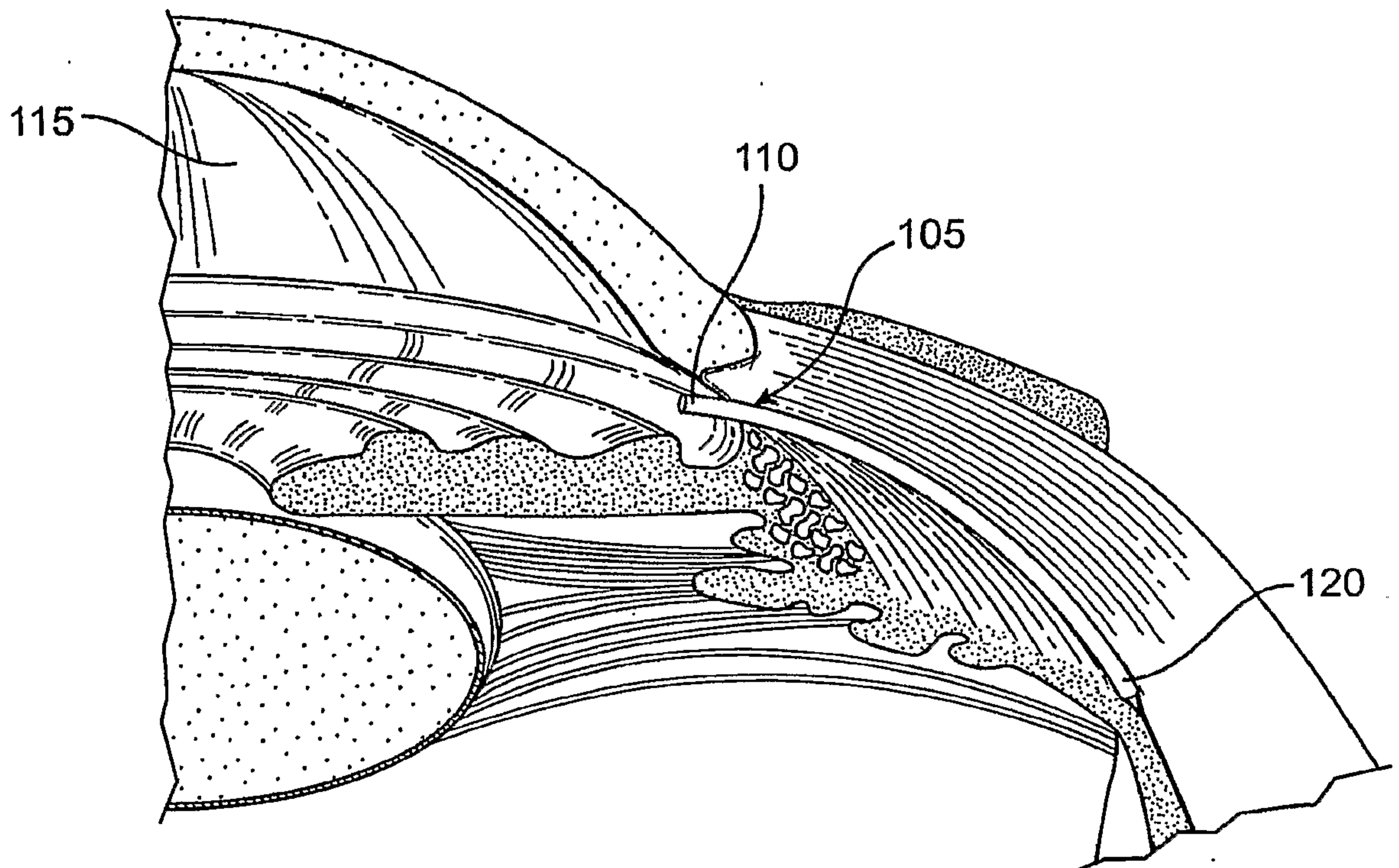

FIG. 1

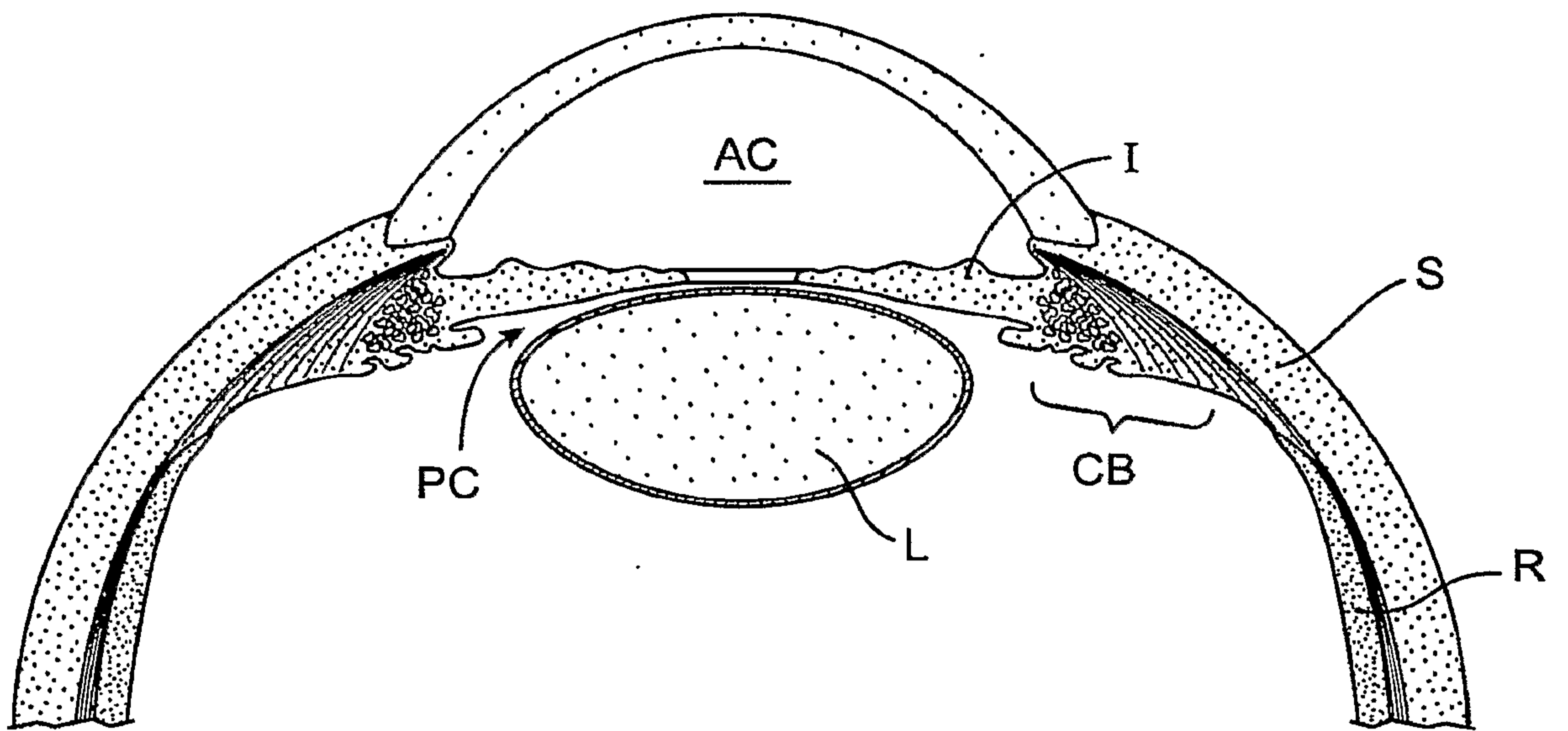

FIG. 2

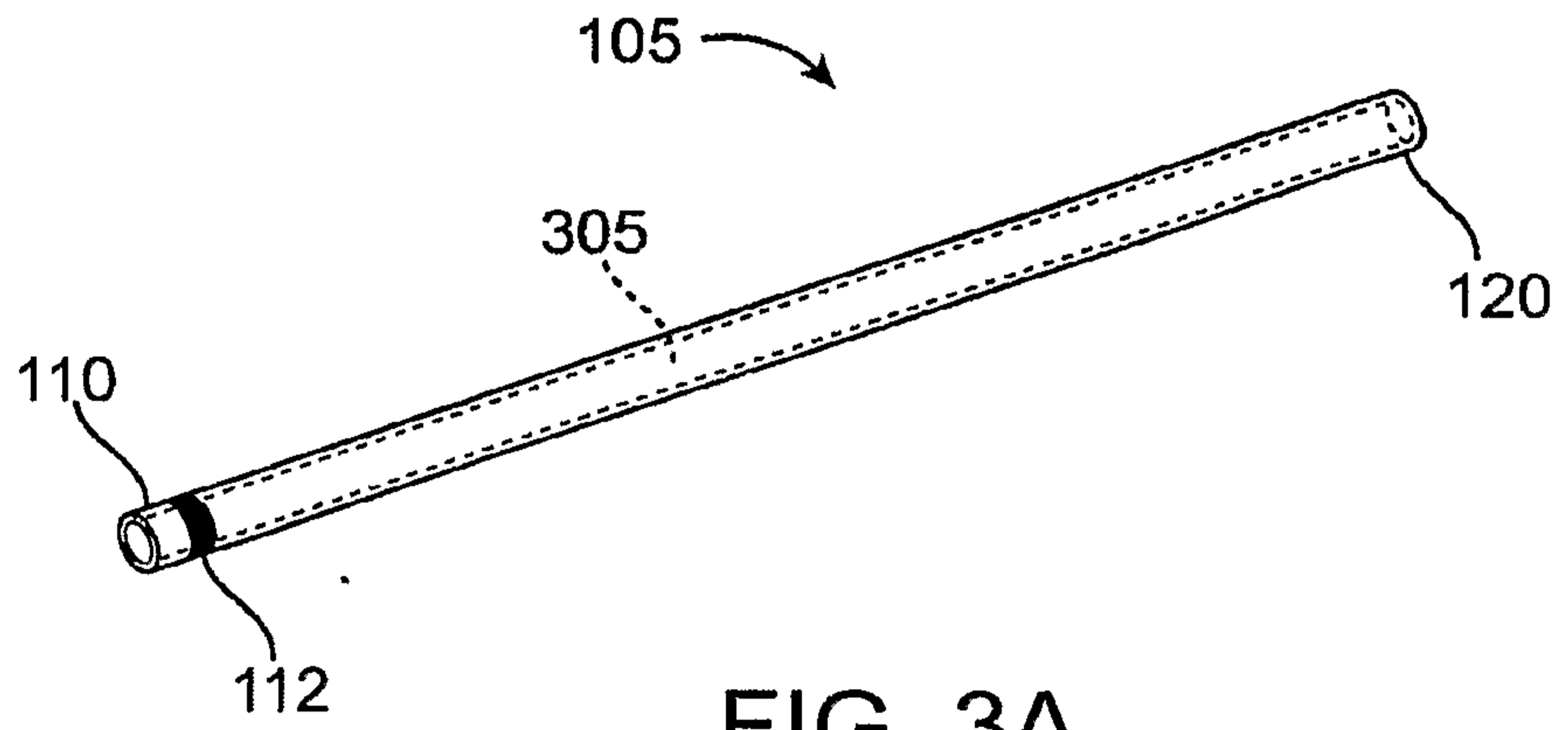

FIG. 3A

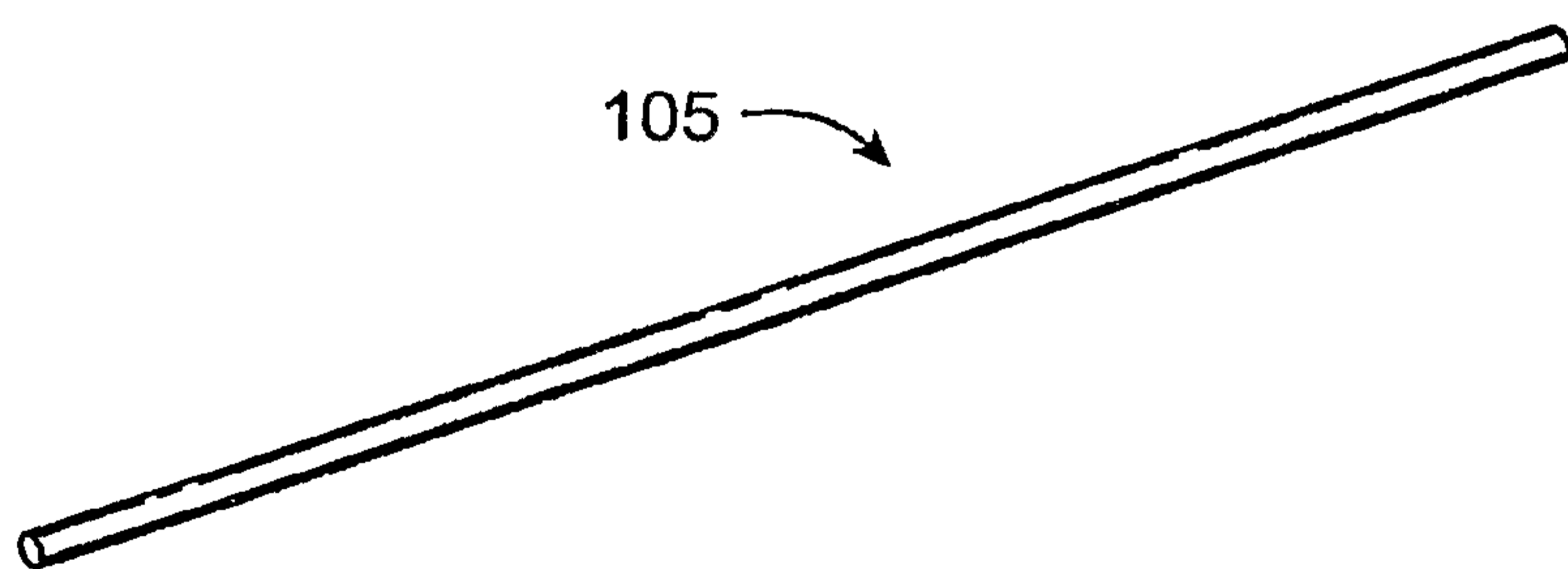
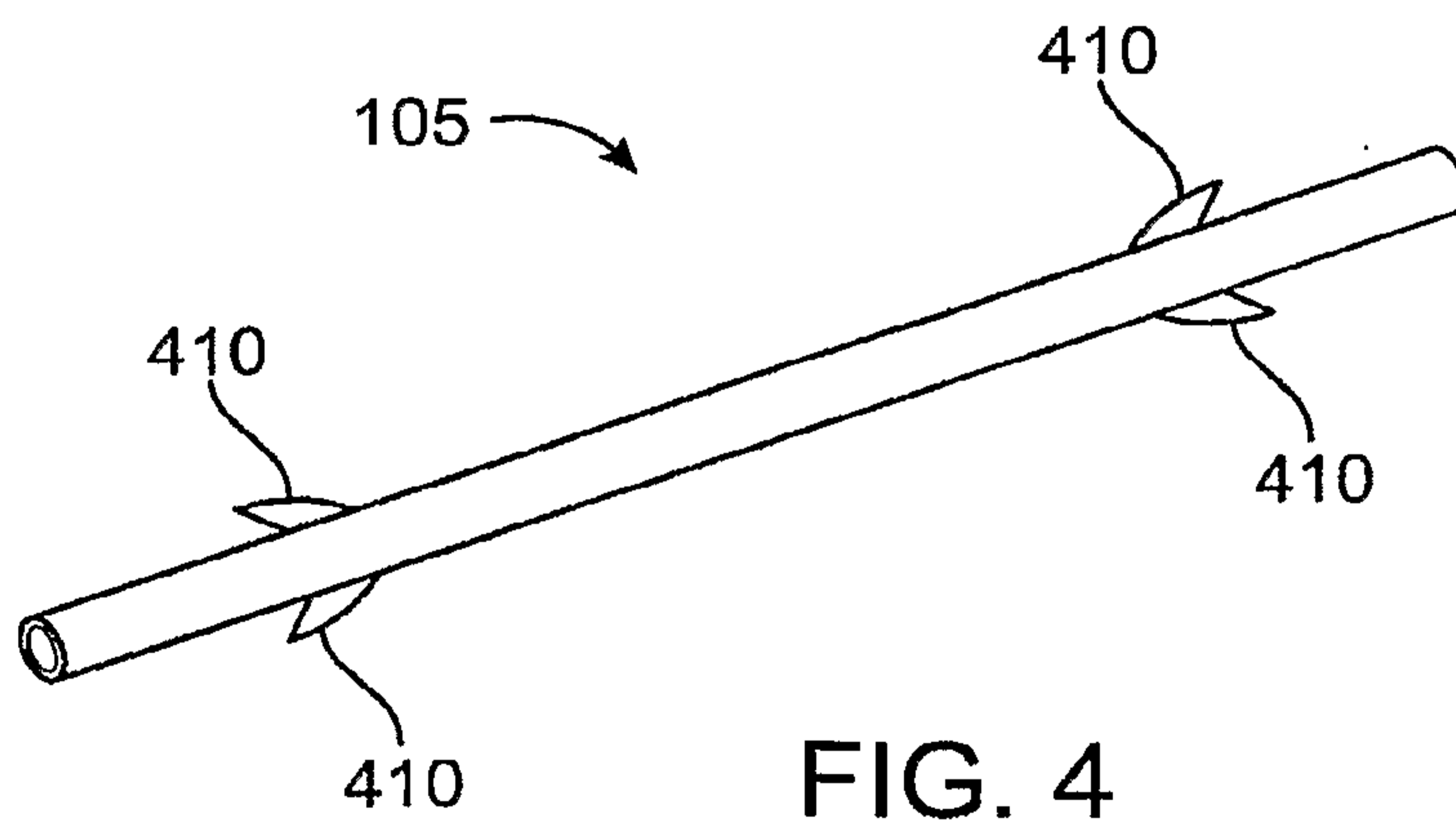
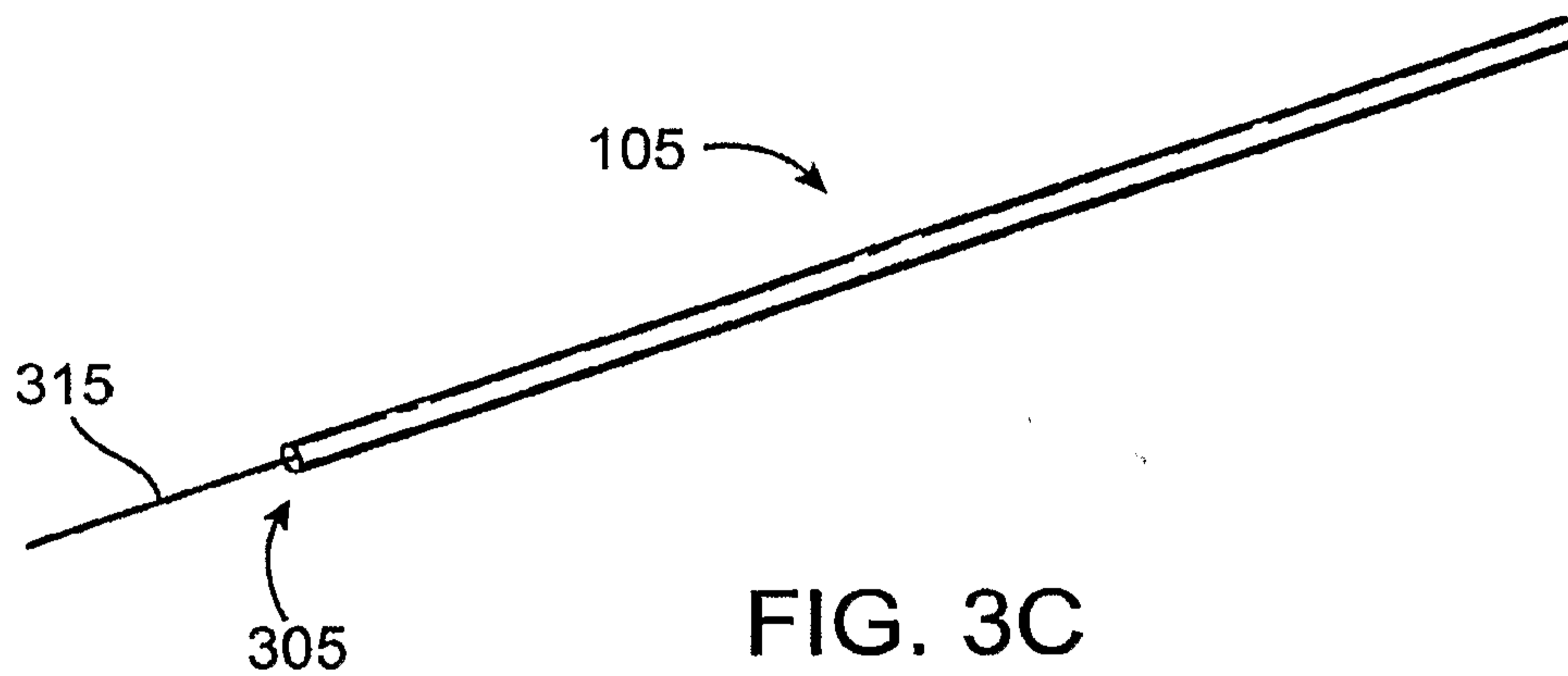

FIG. 3B



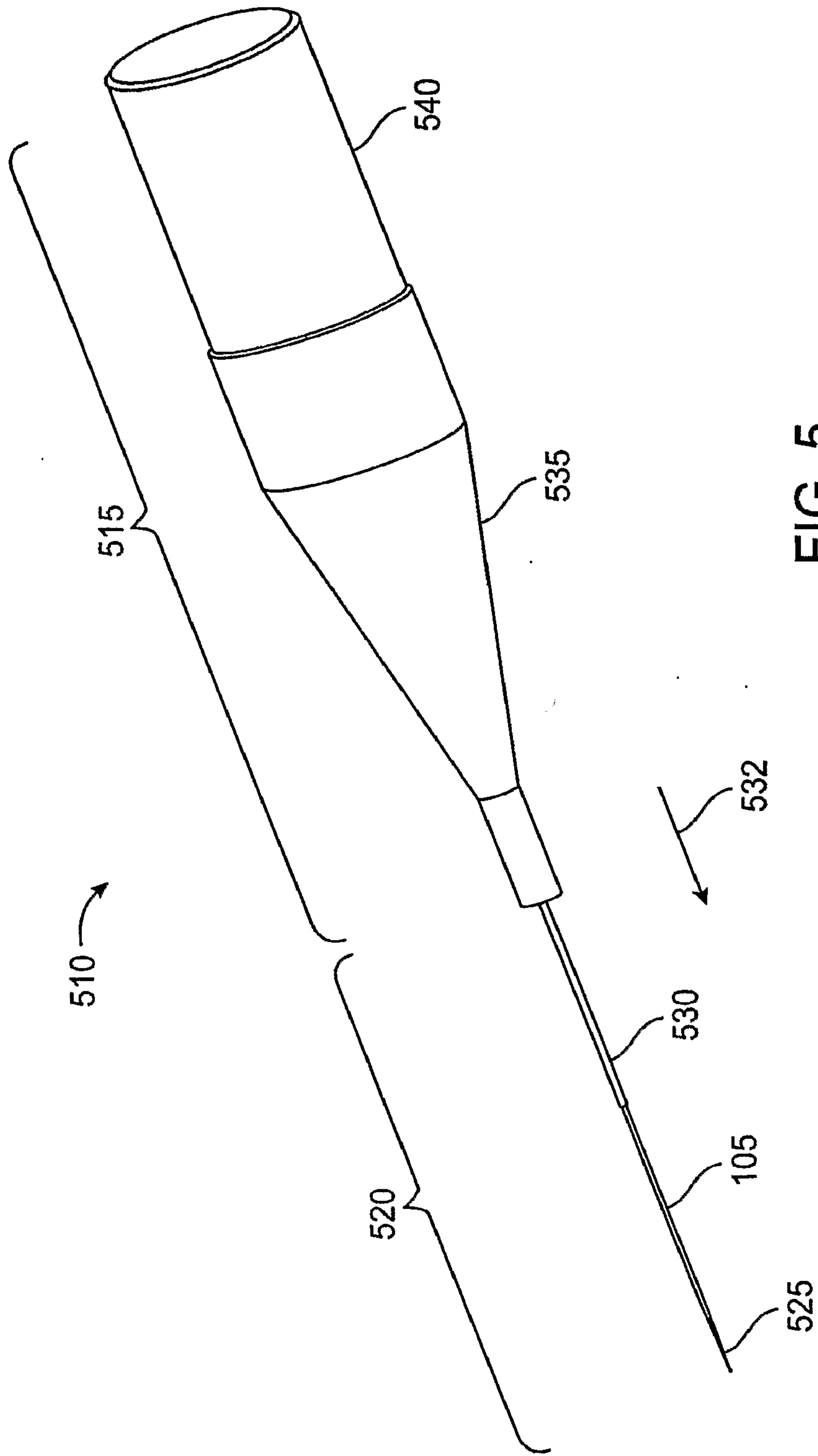
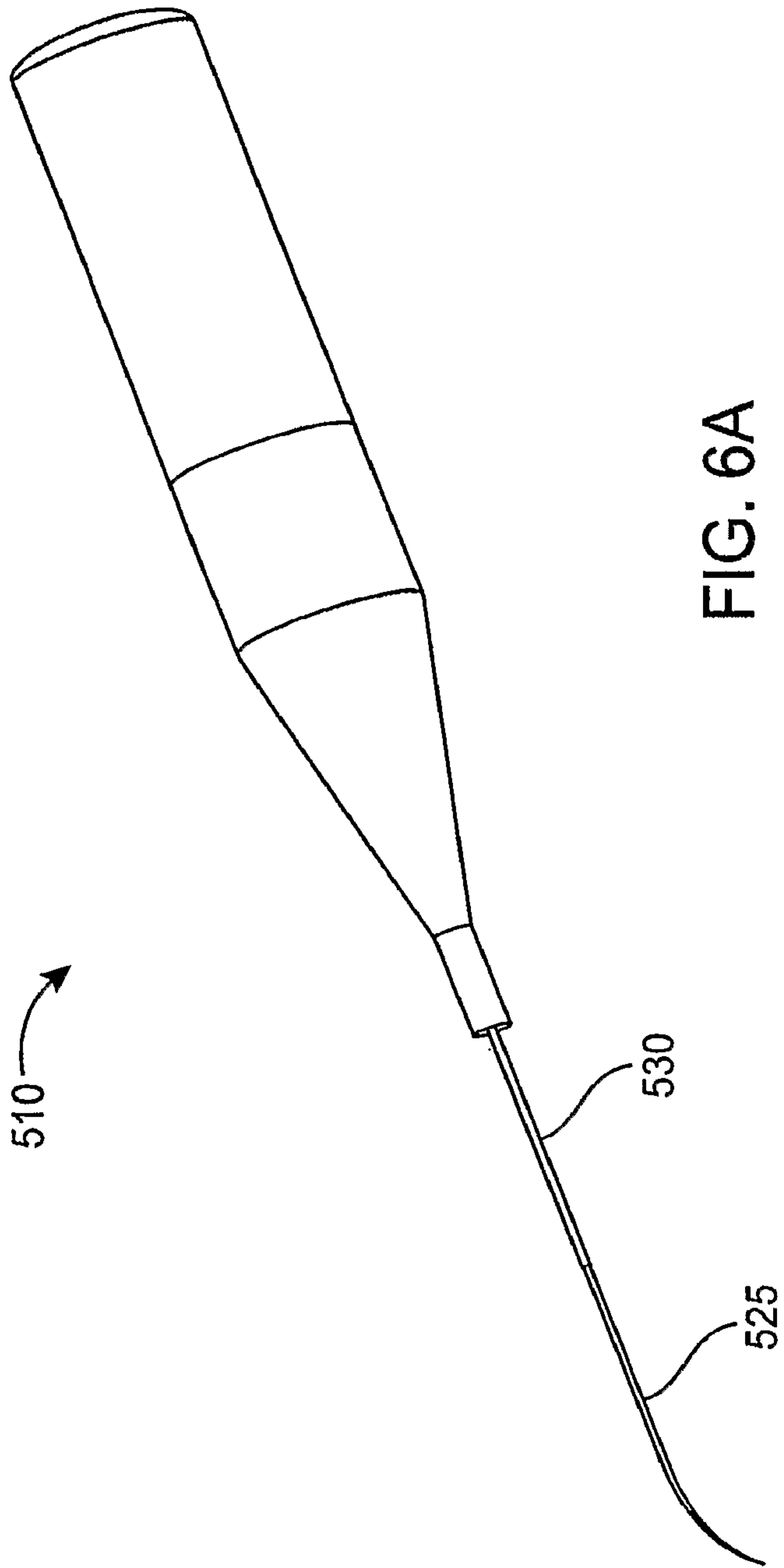

FIG. 5



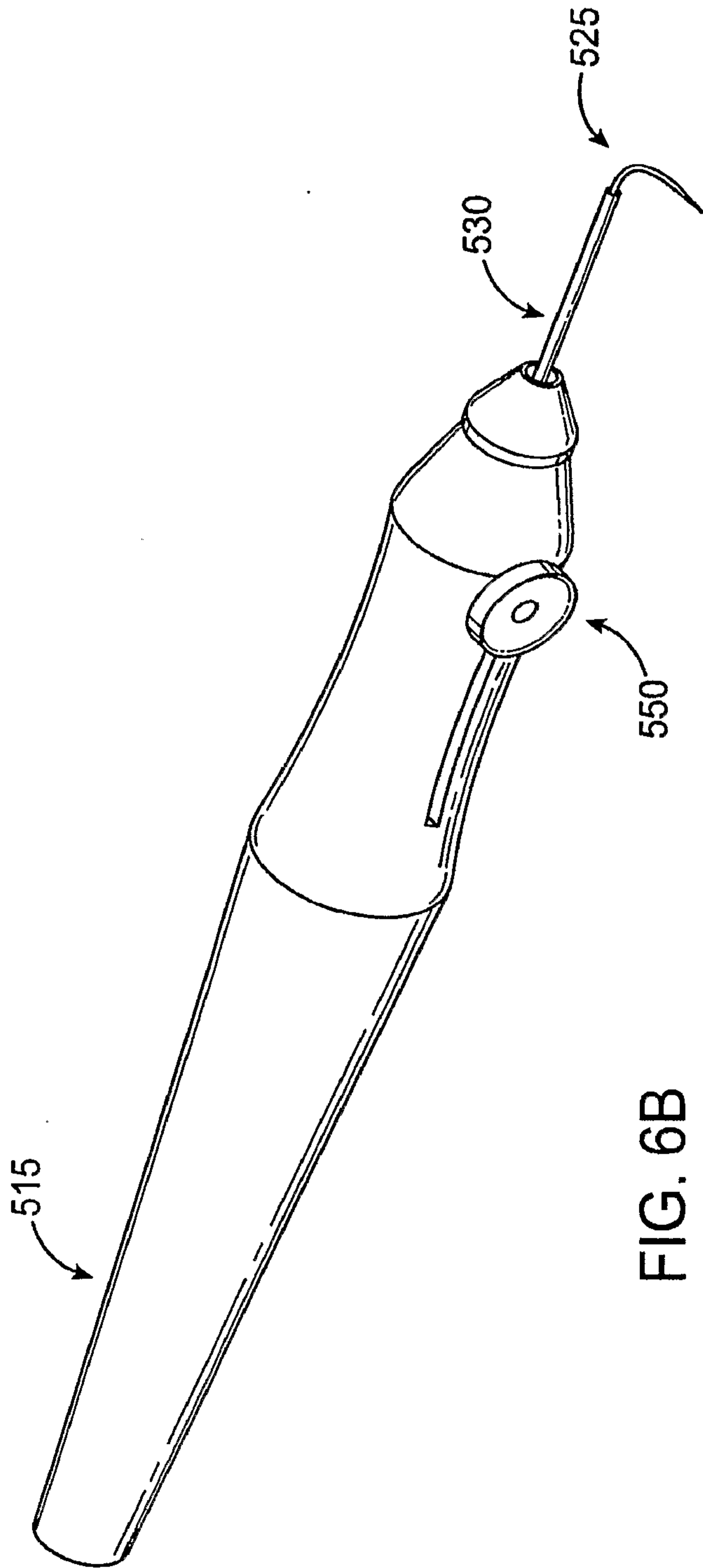

FIG. 6B

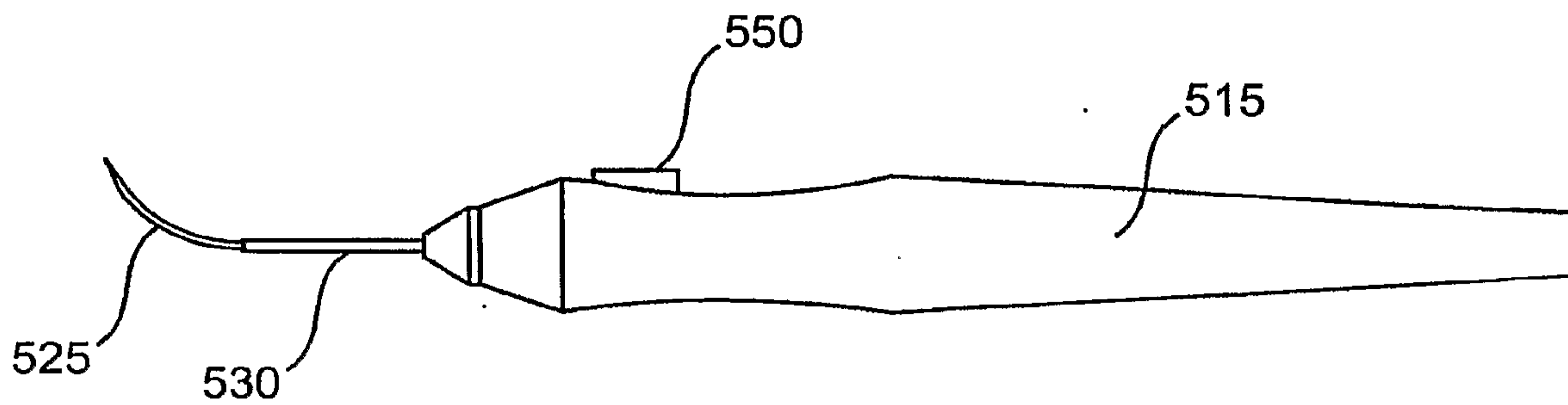

FIG. 6C

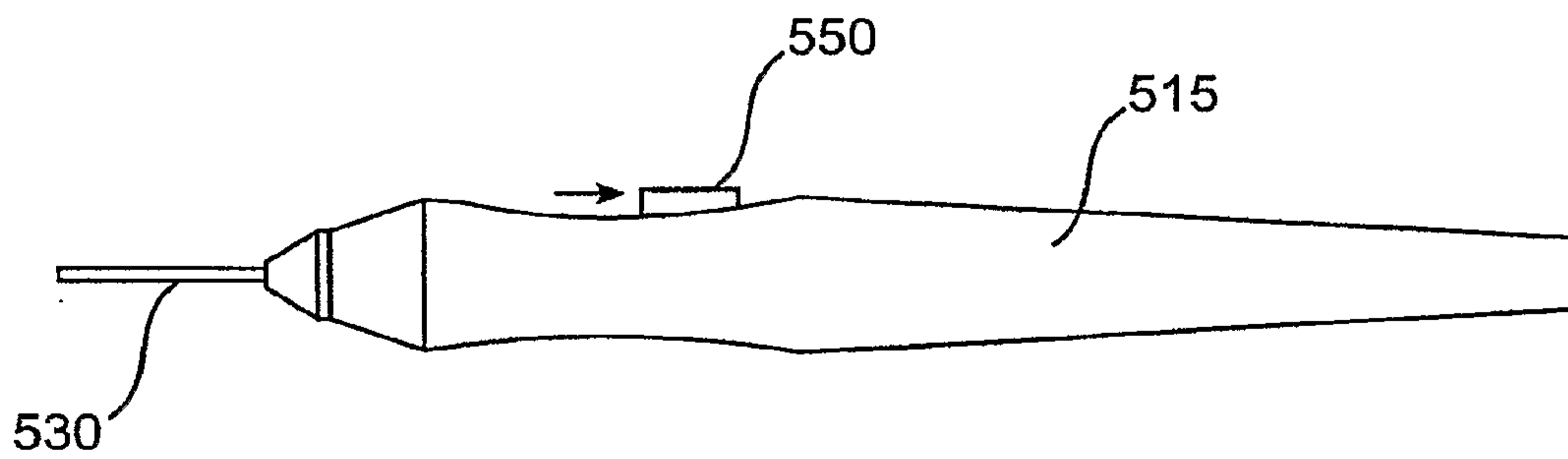

FIG. 6D

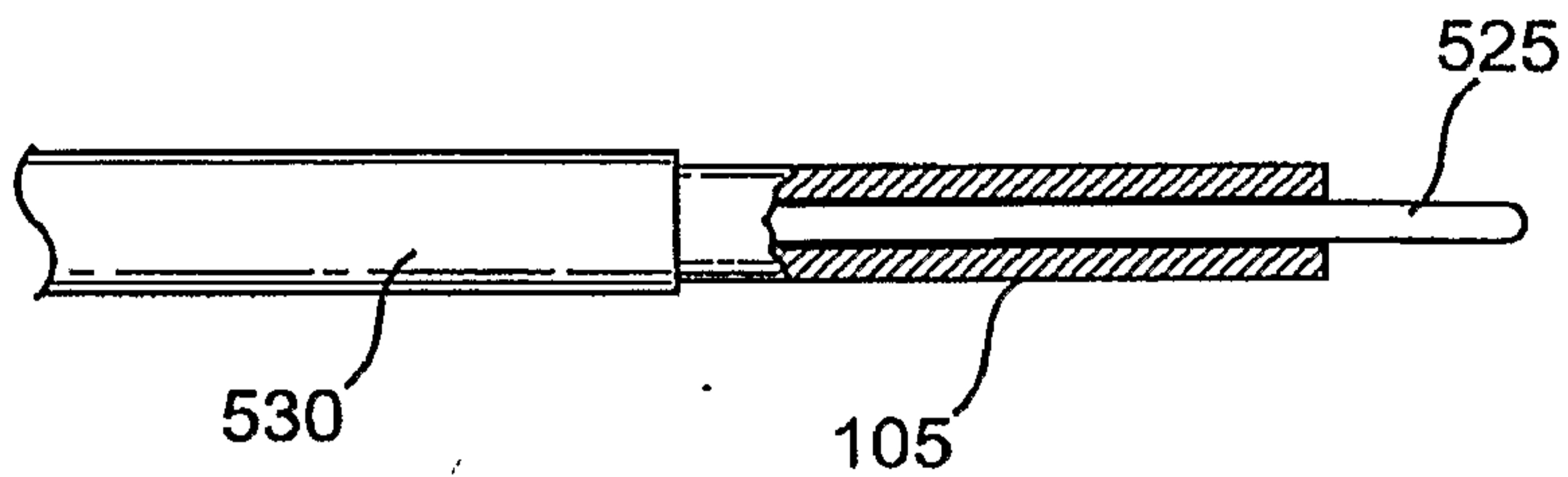

FIG. 6E

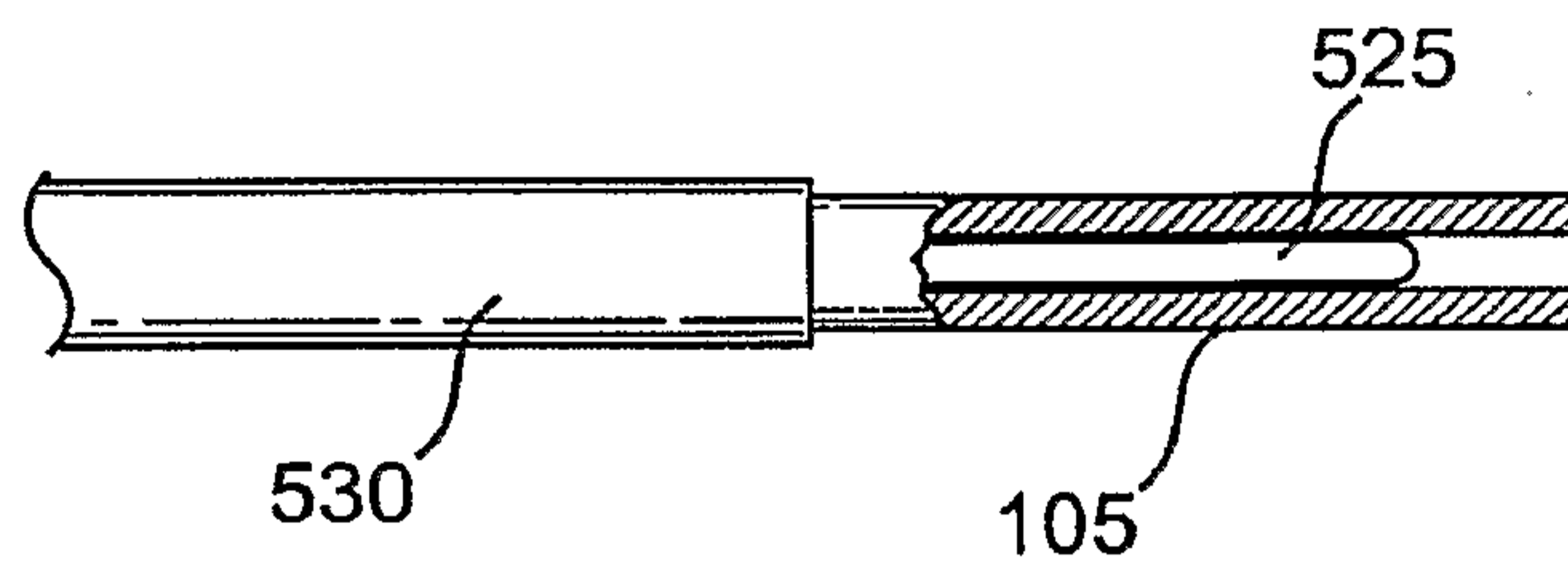

FIG. 6F

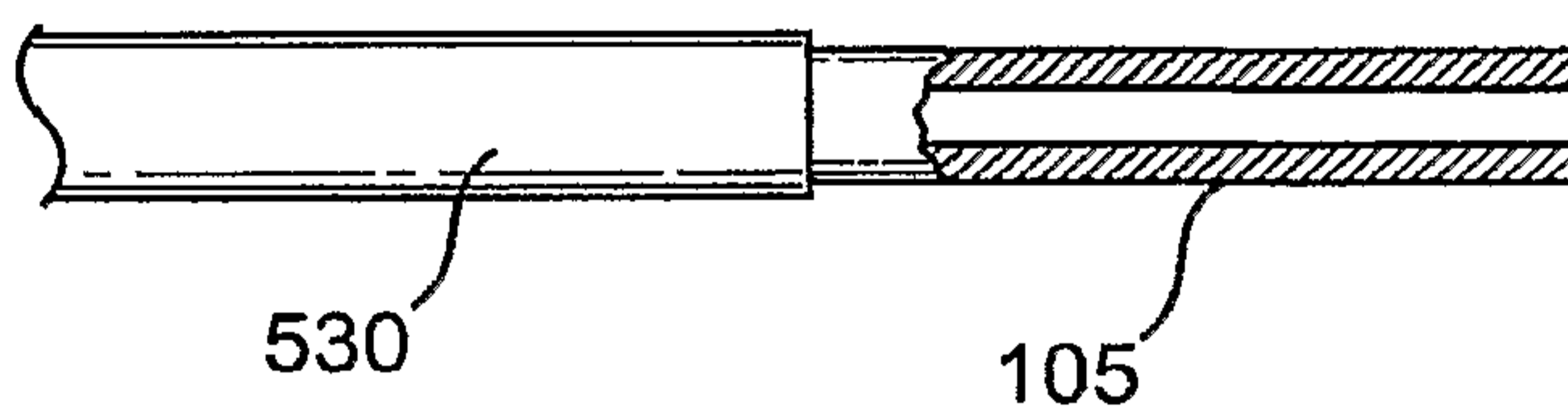

FIG. 6G

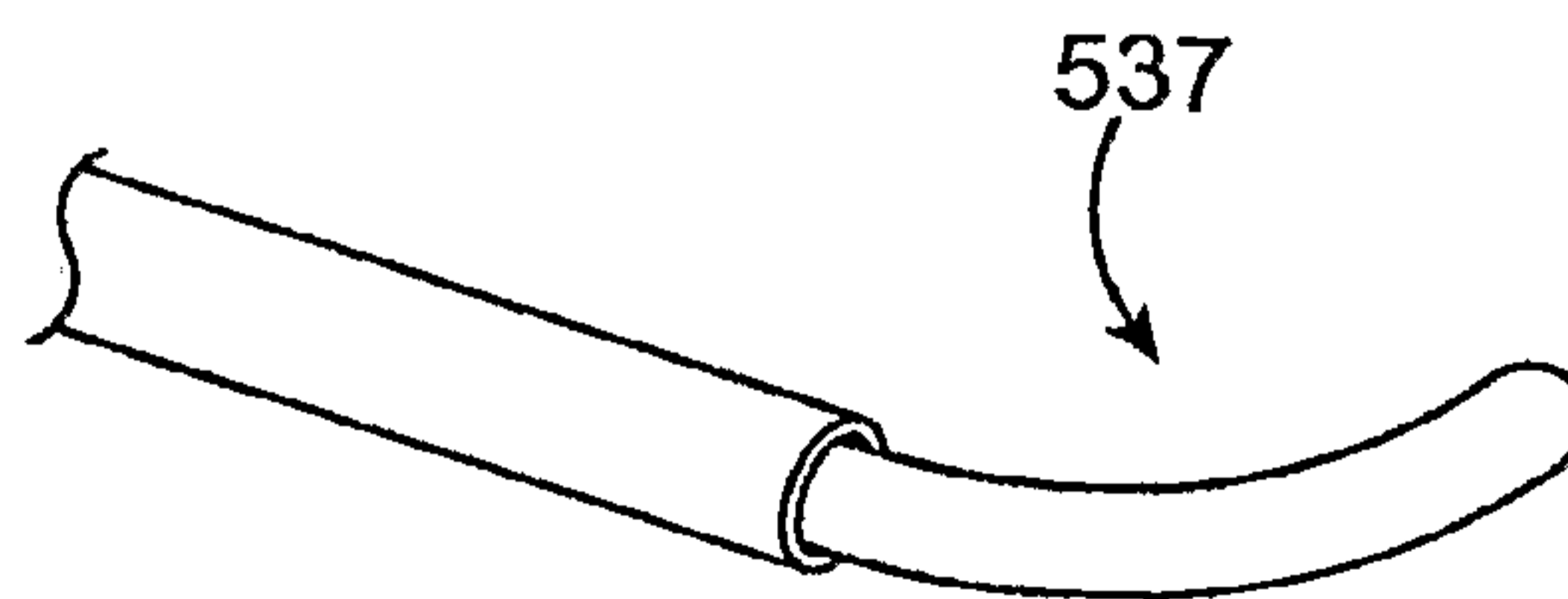
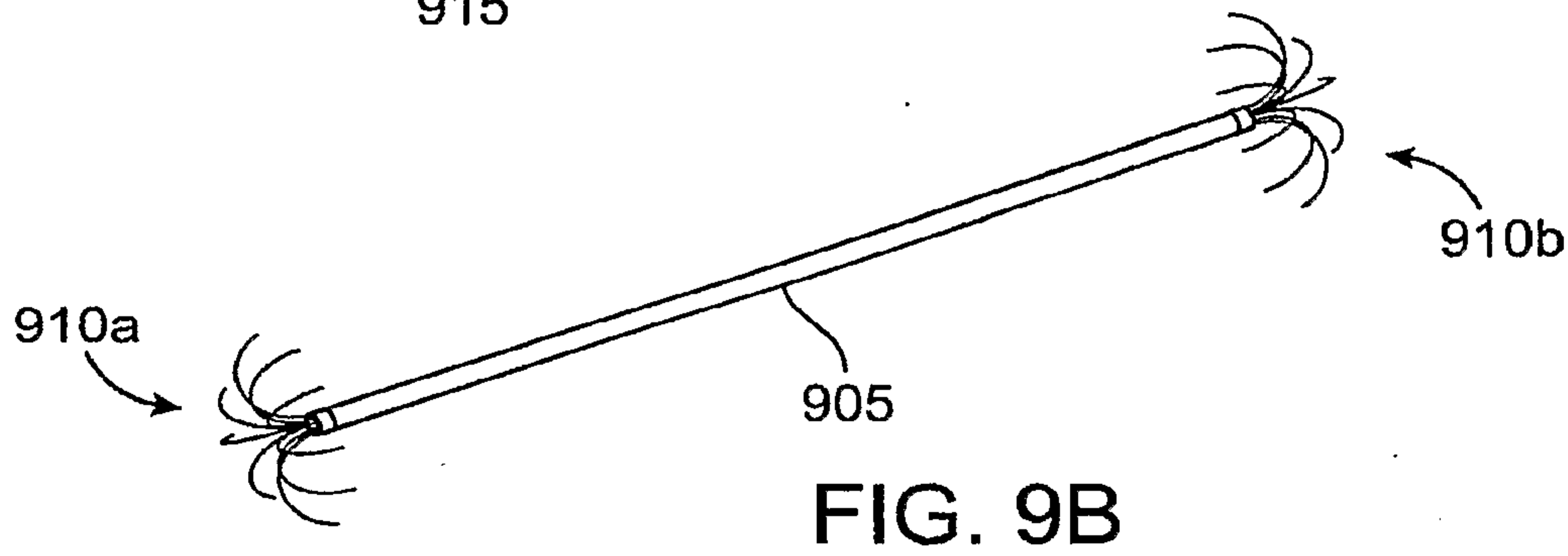
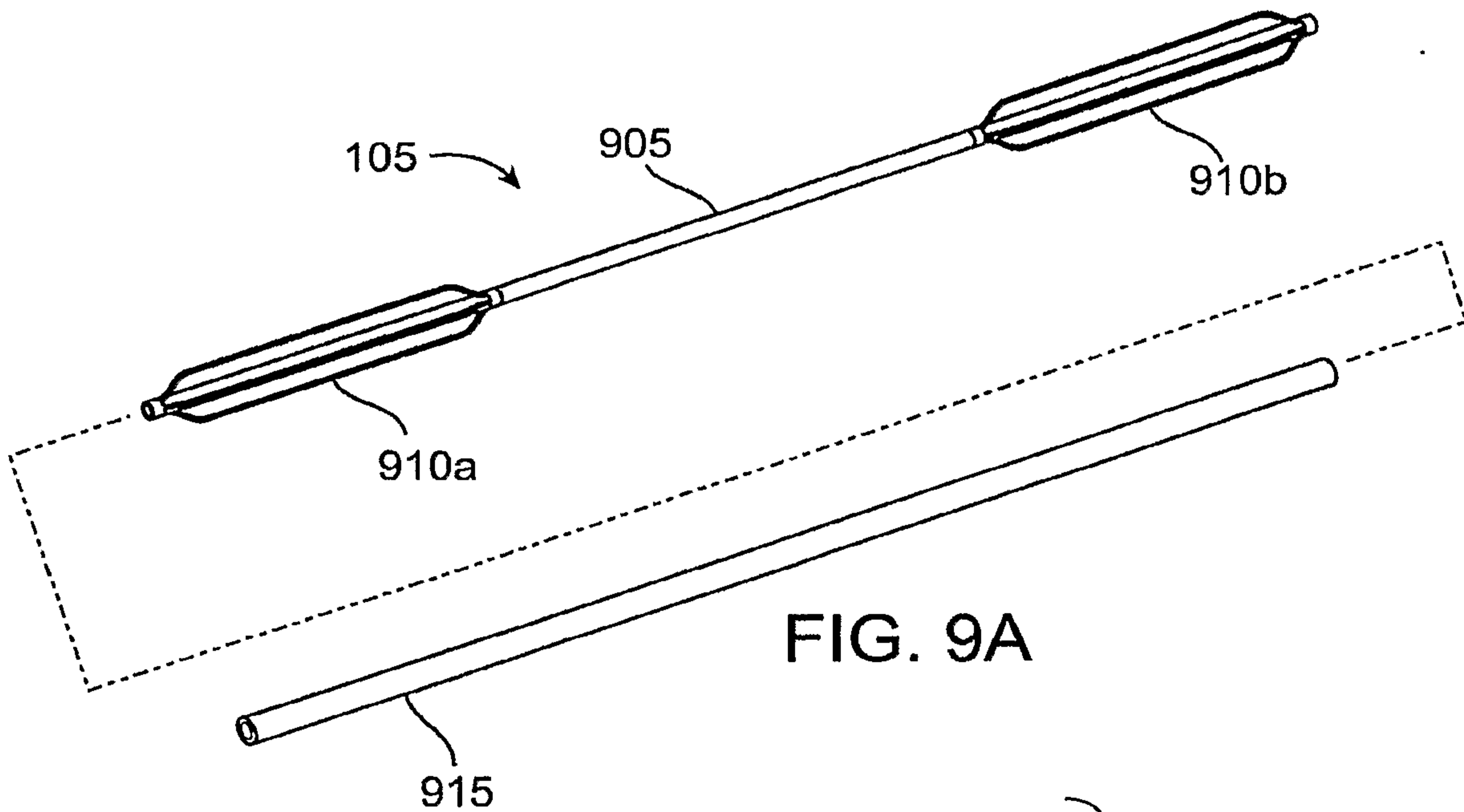
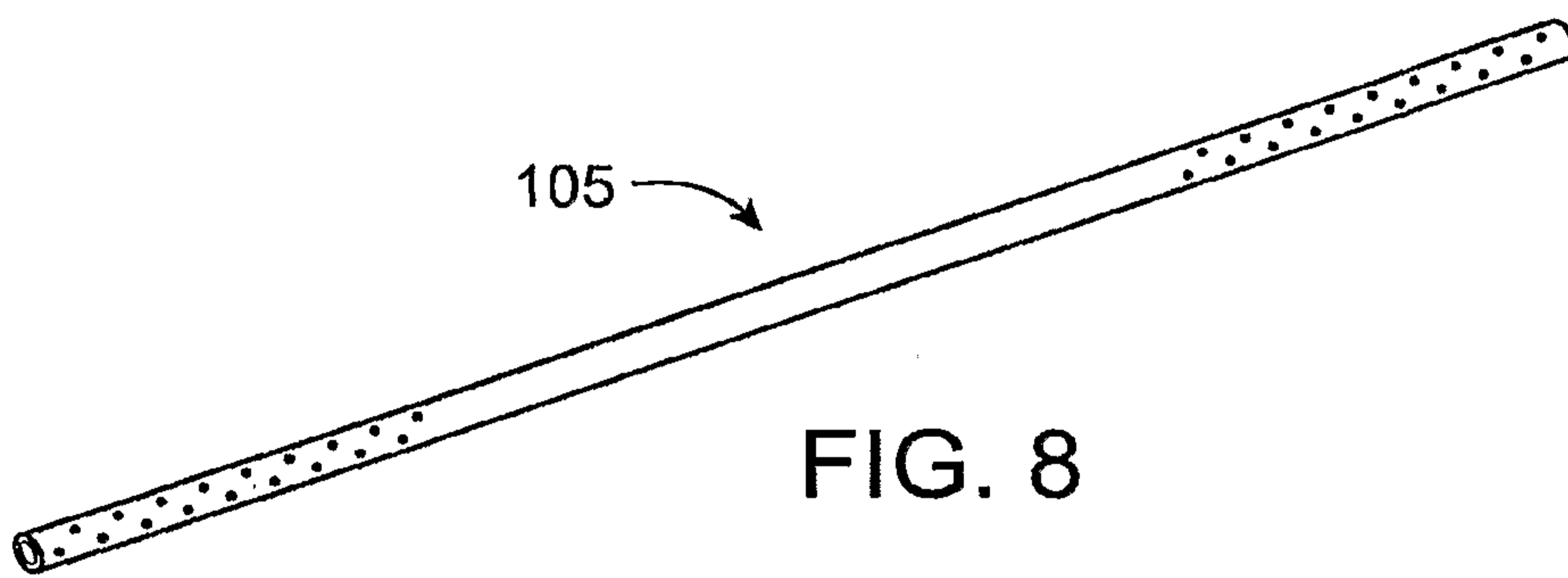
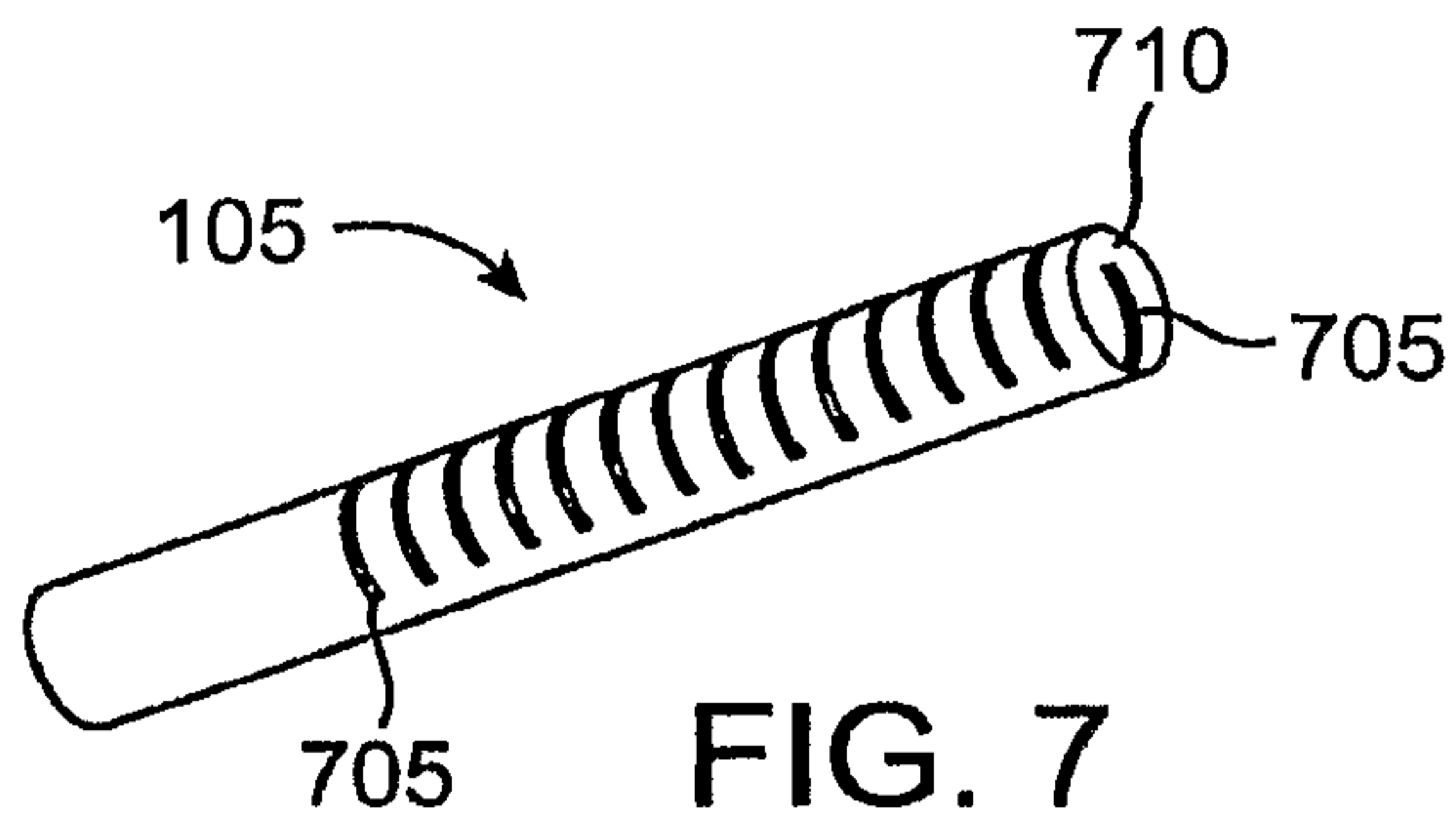
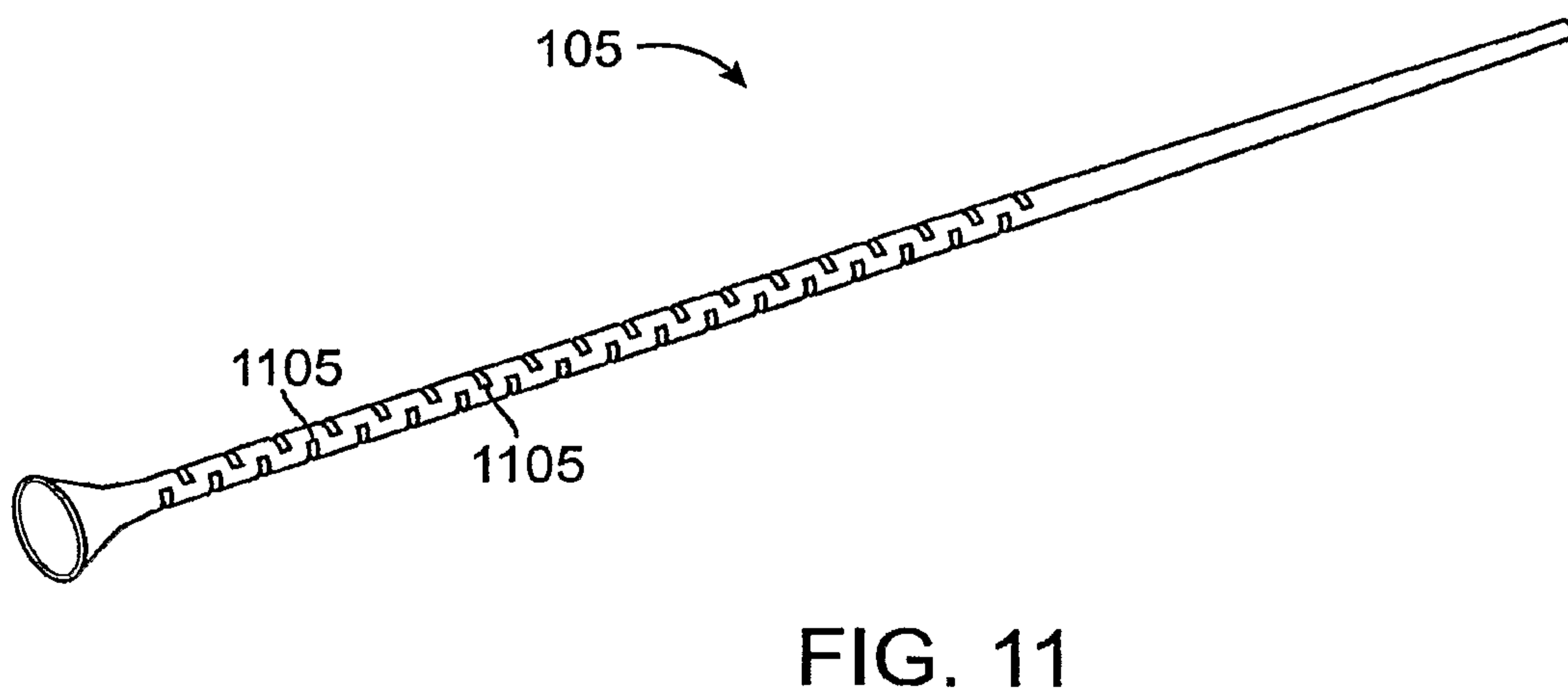
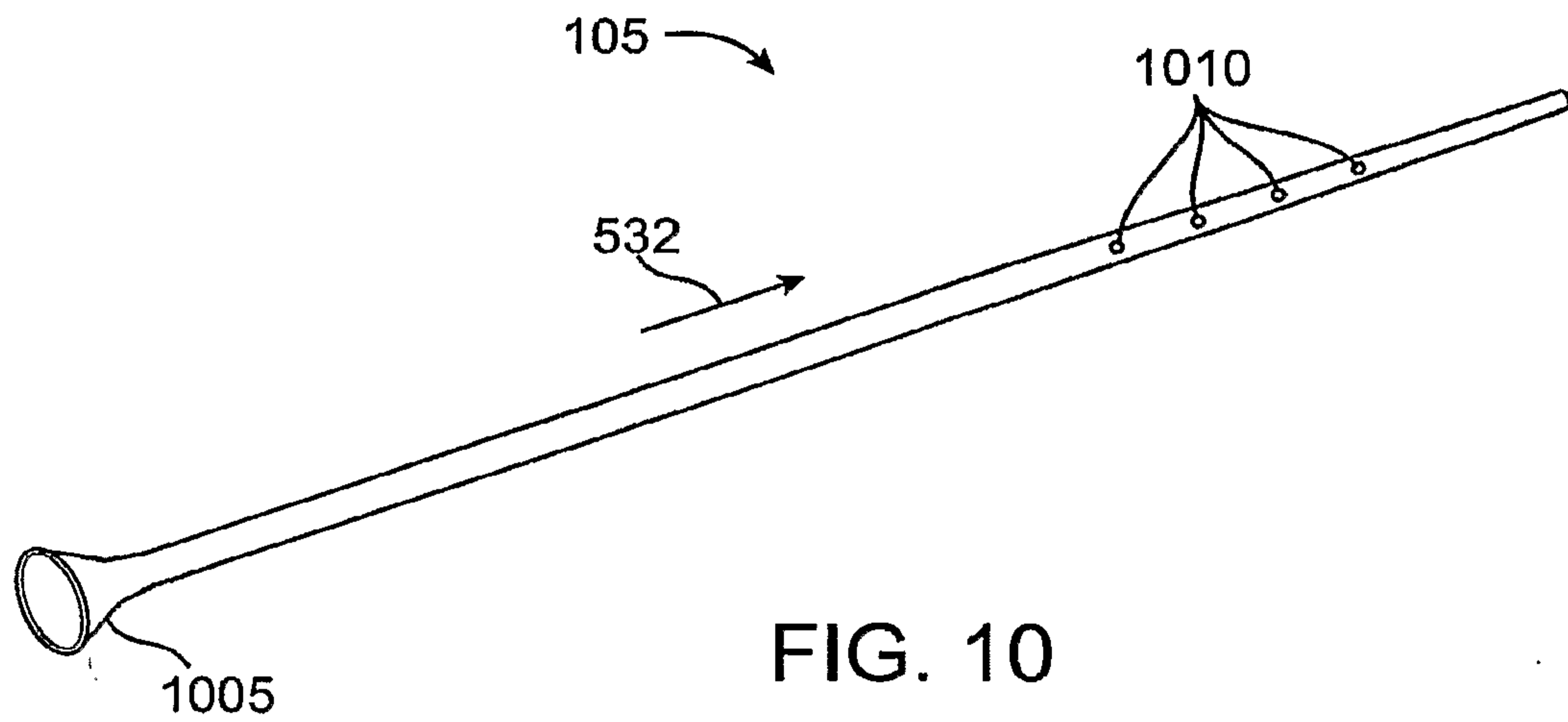

FIG. 6H





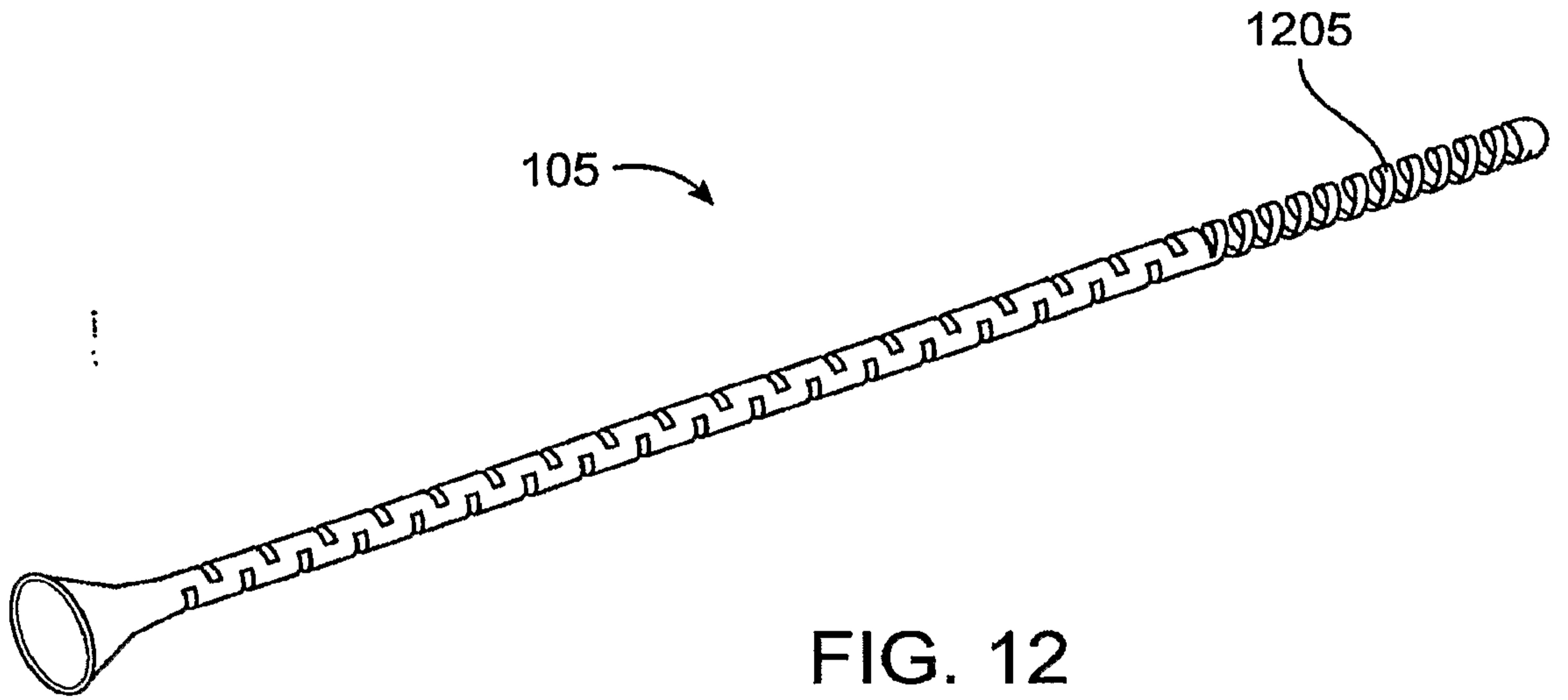

FIG. 12

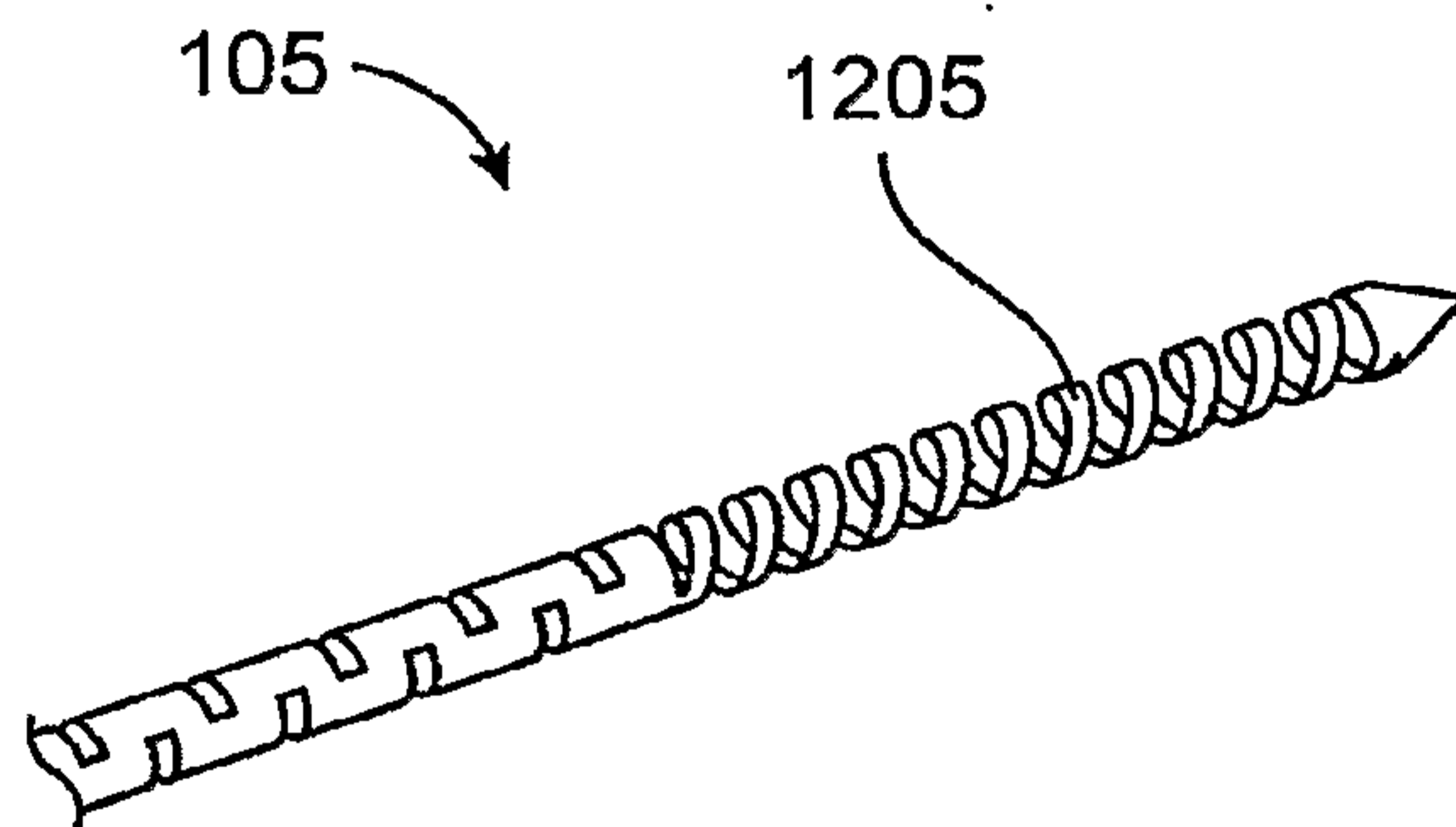

FIG. 13

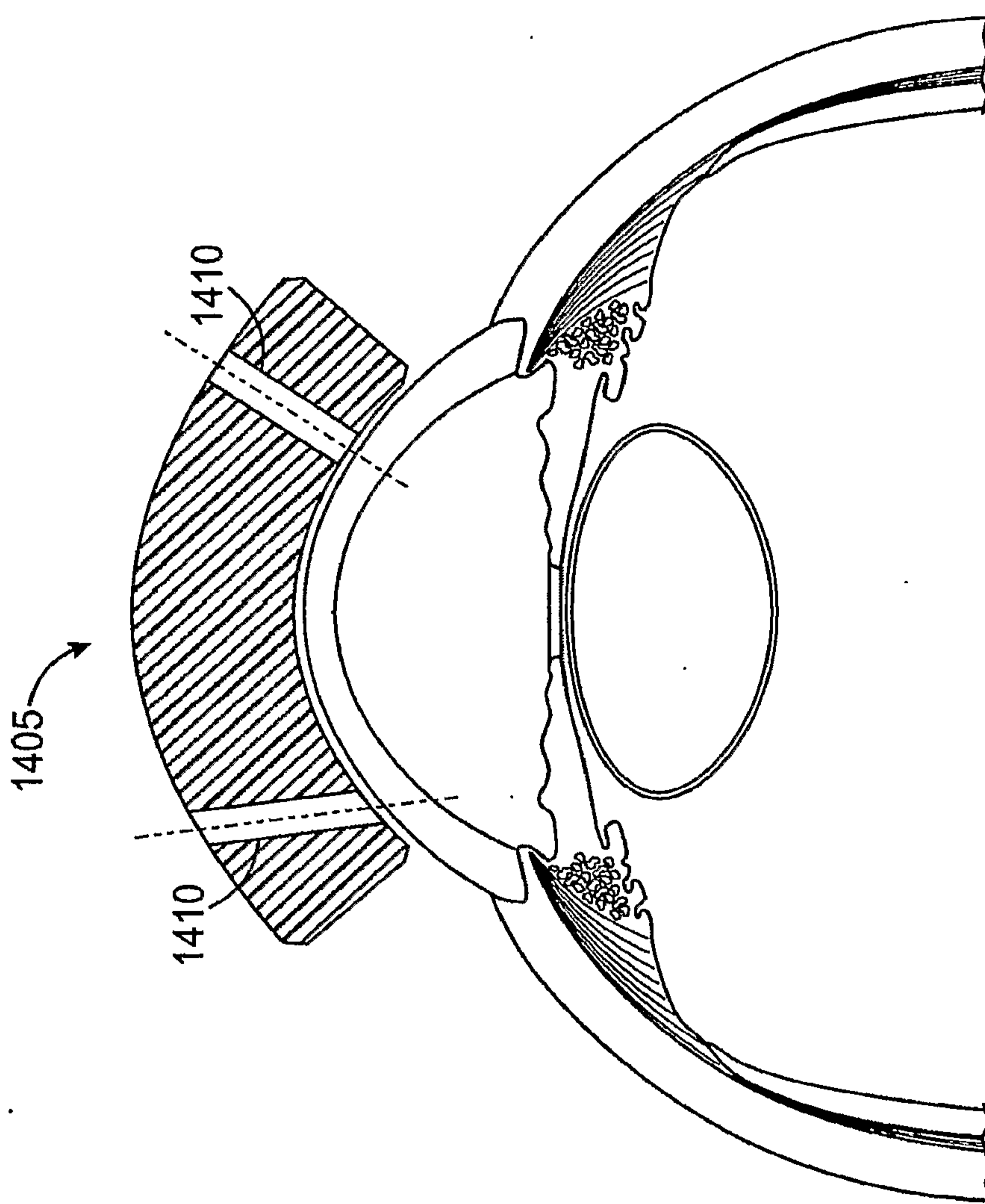

FIG. 14

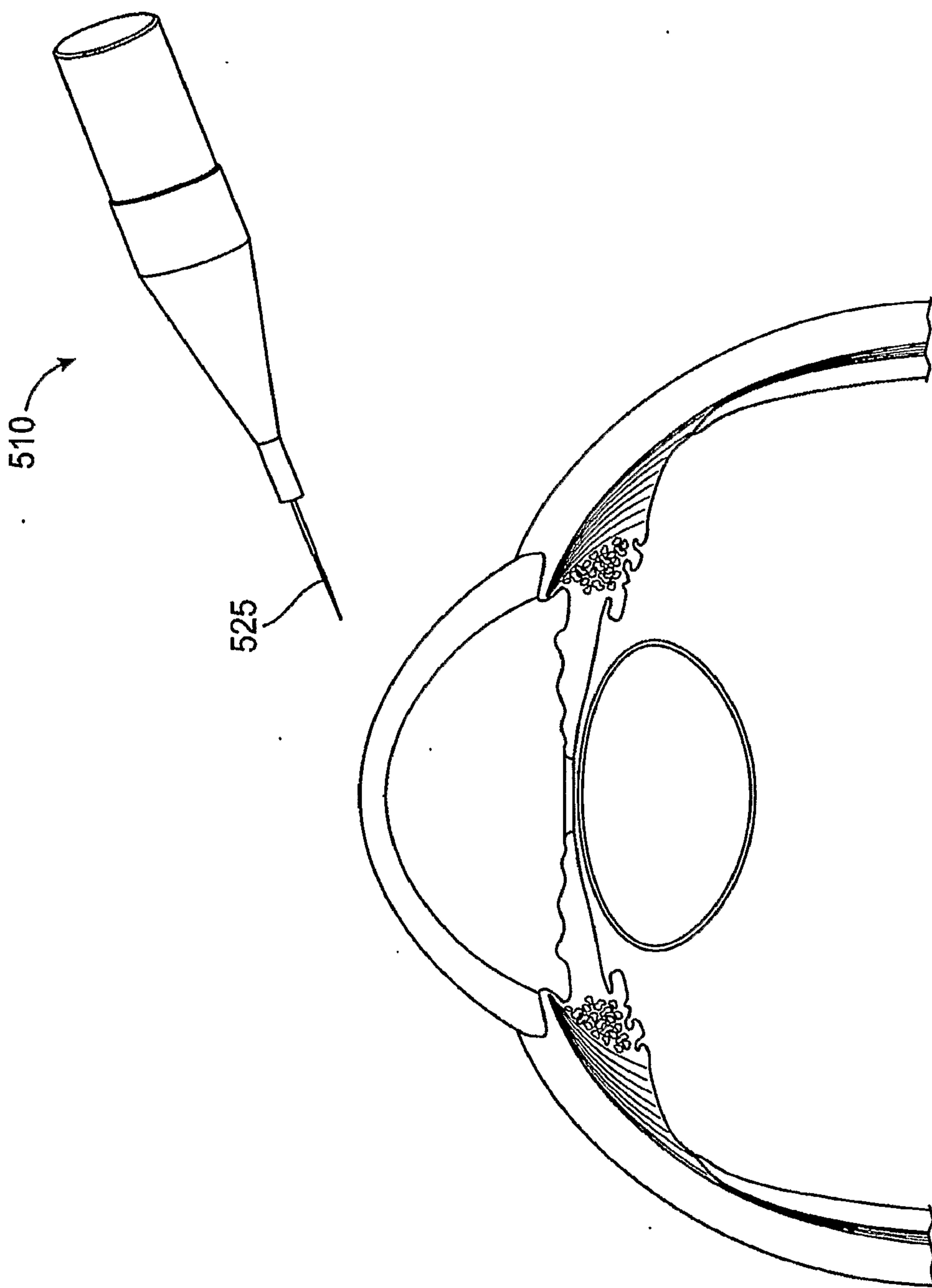

FIG. 15A

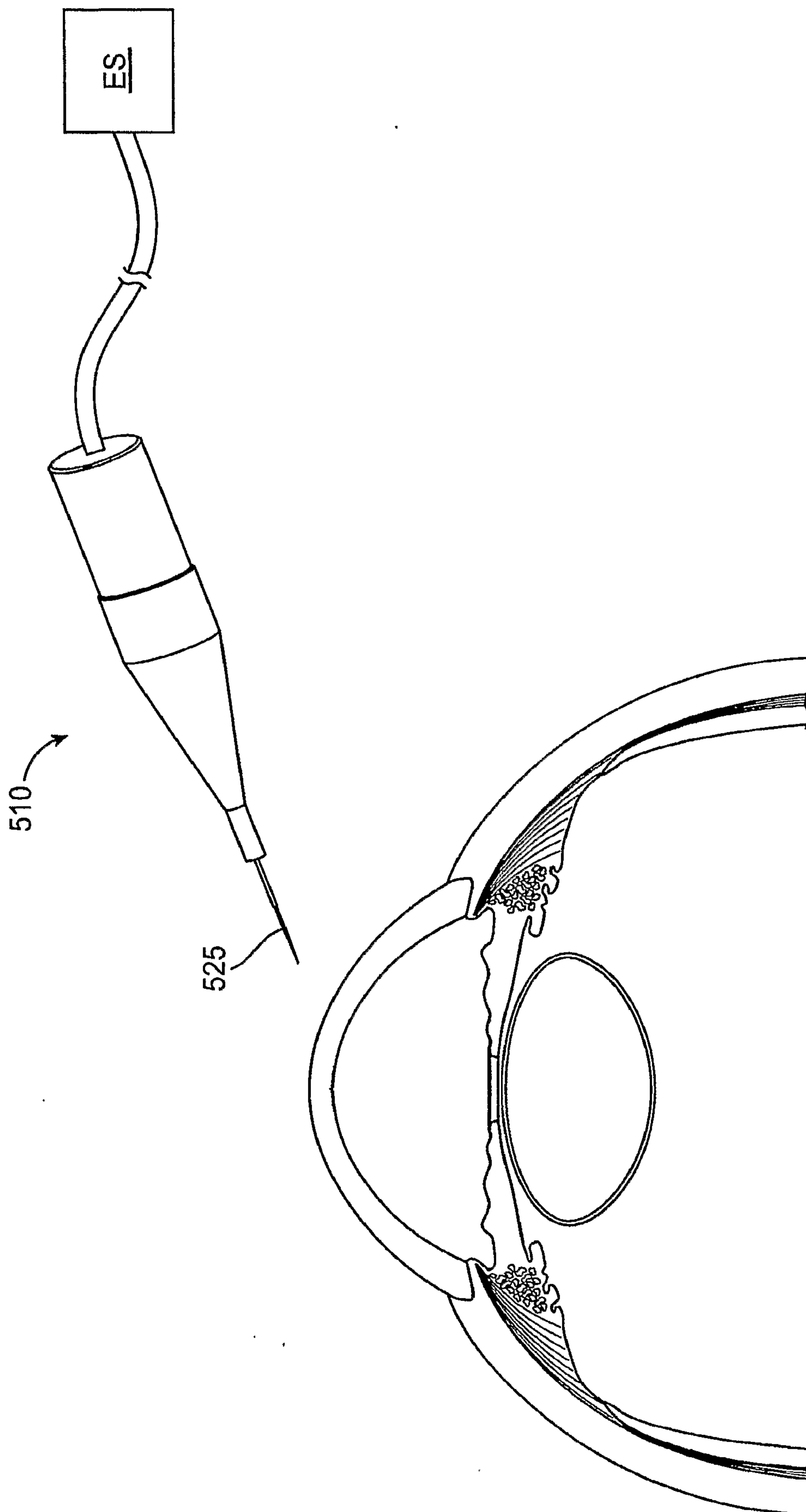

FIG. 15B

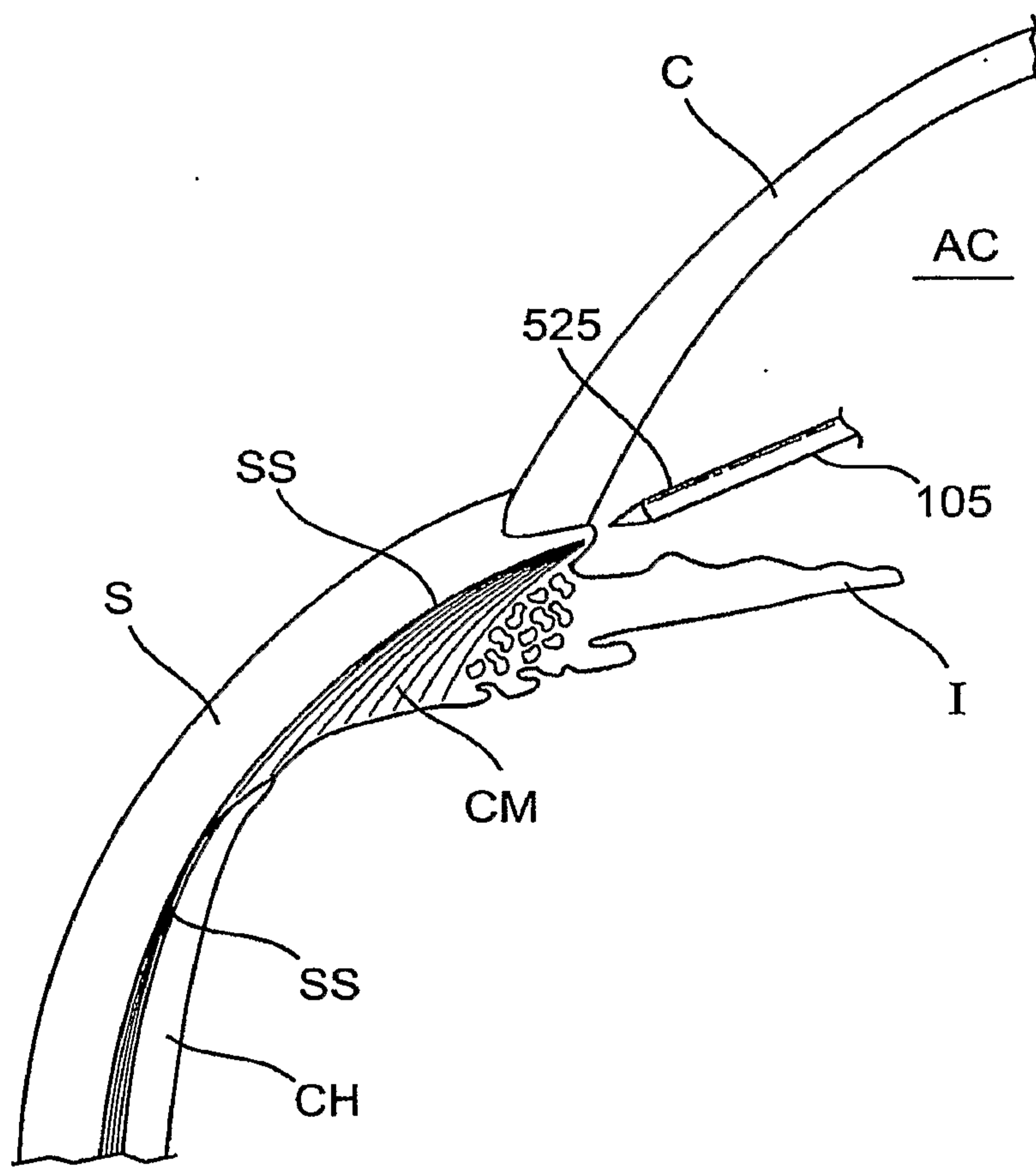

FIG. 16

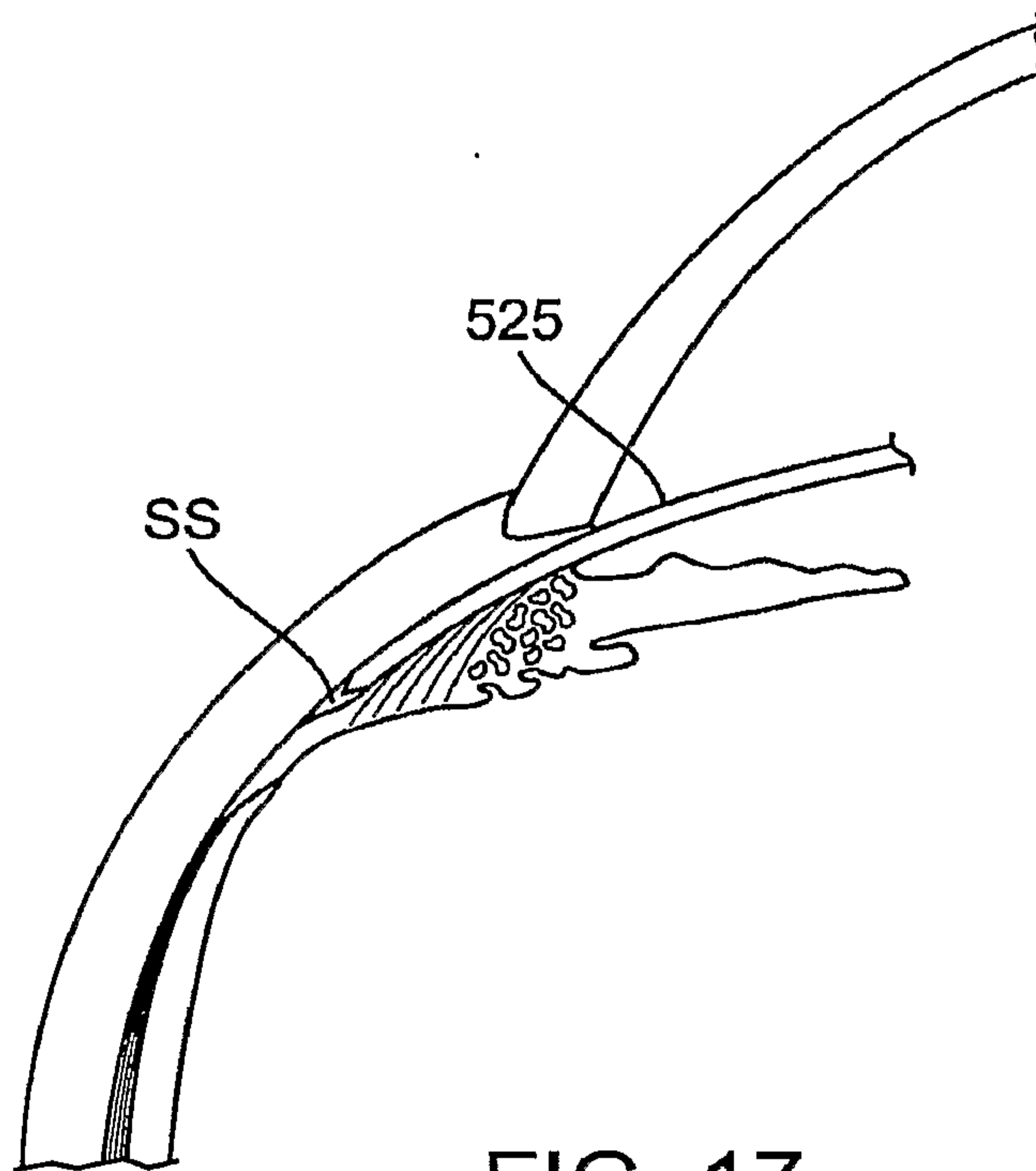

FIG. 17

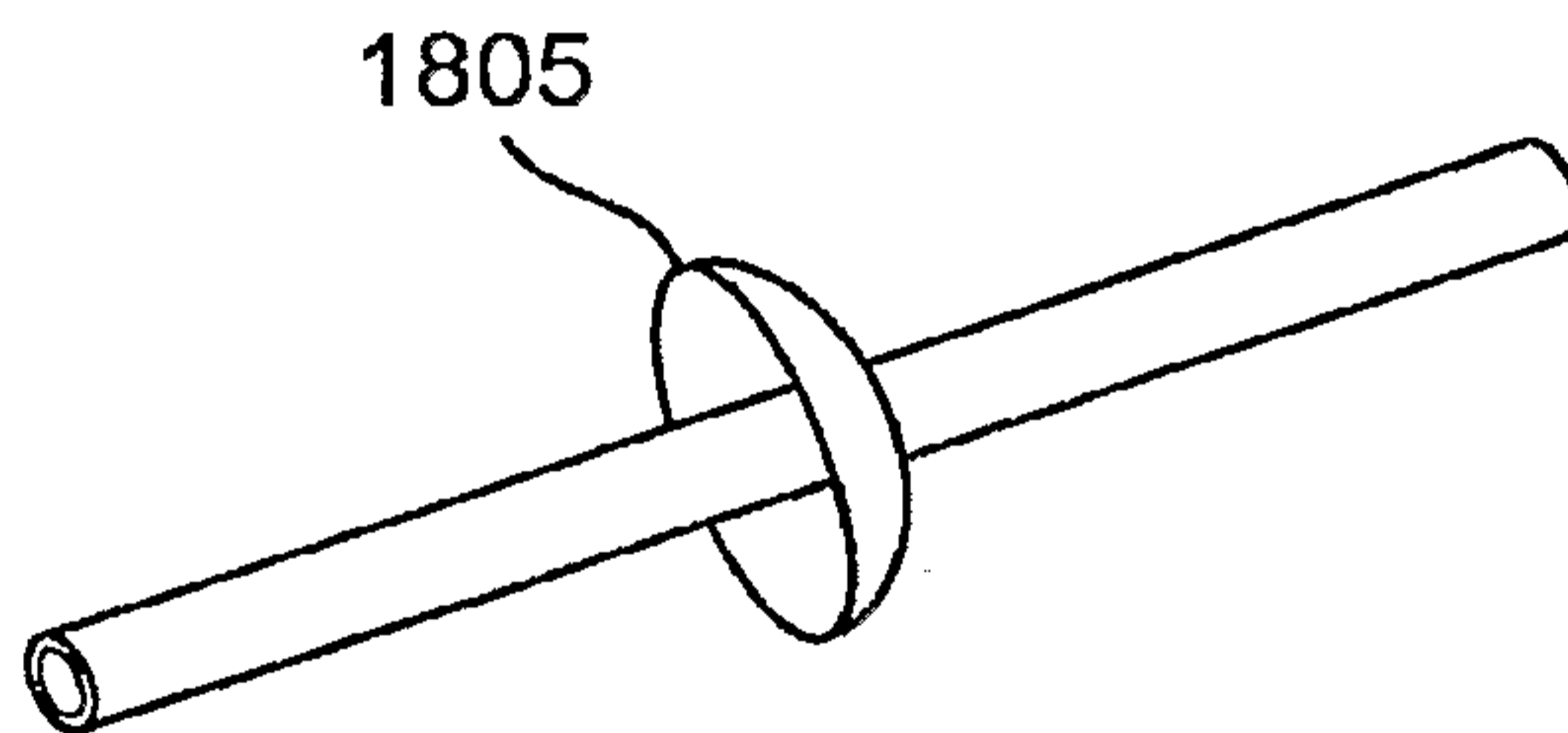

FIG. 18

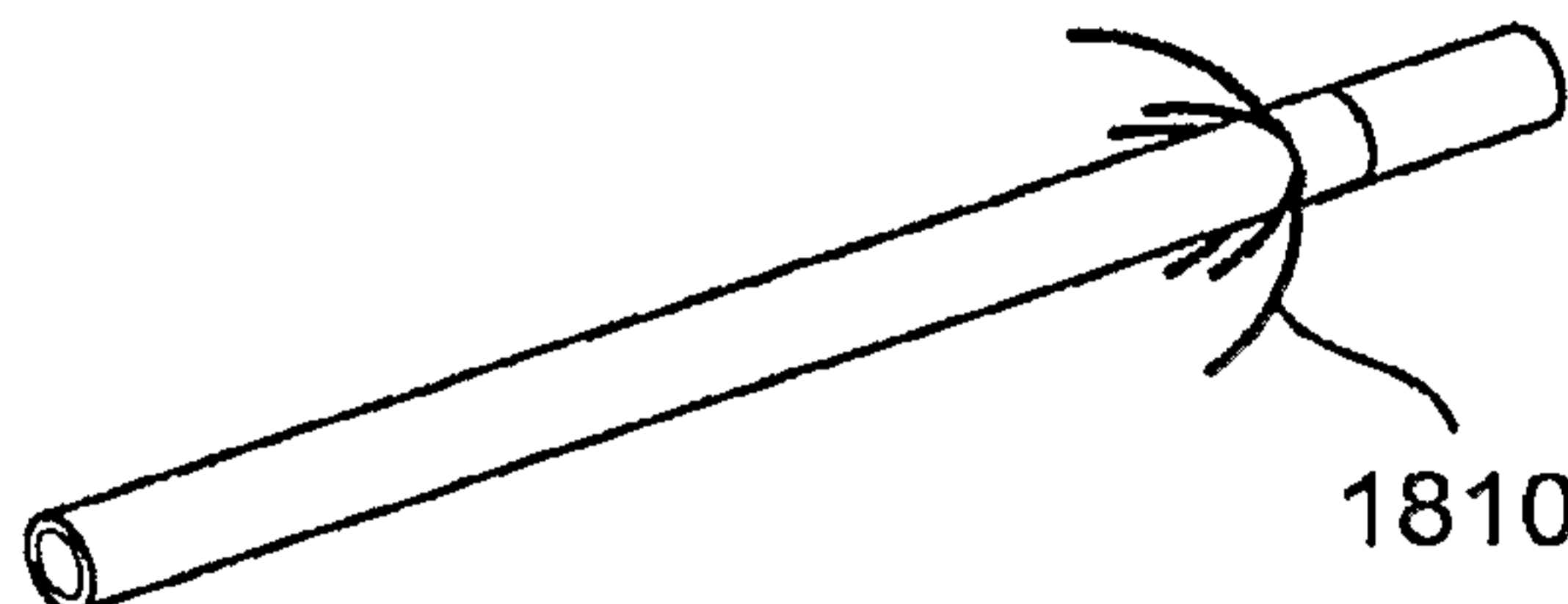

FIG. 19

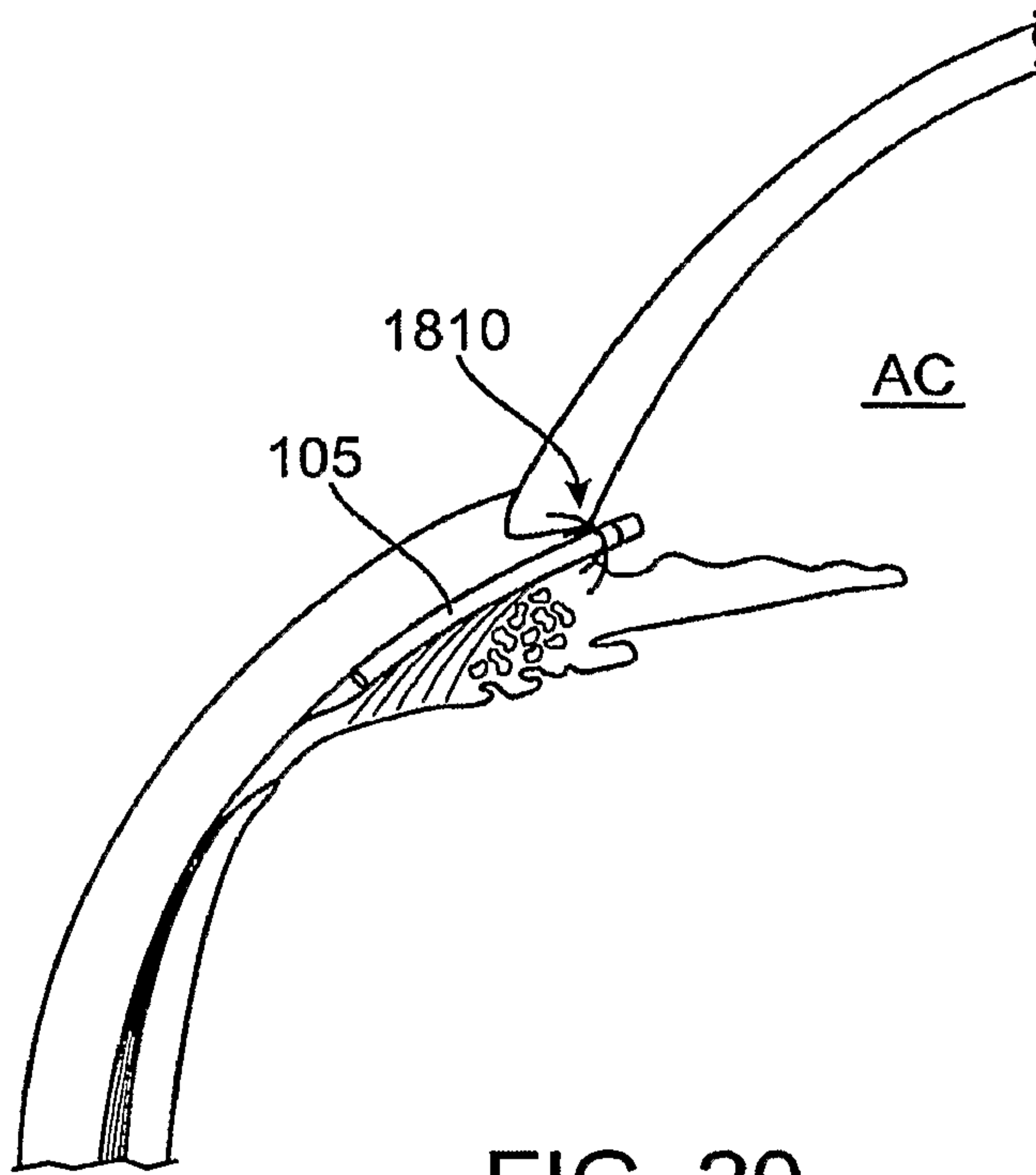

FIG. 20

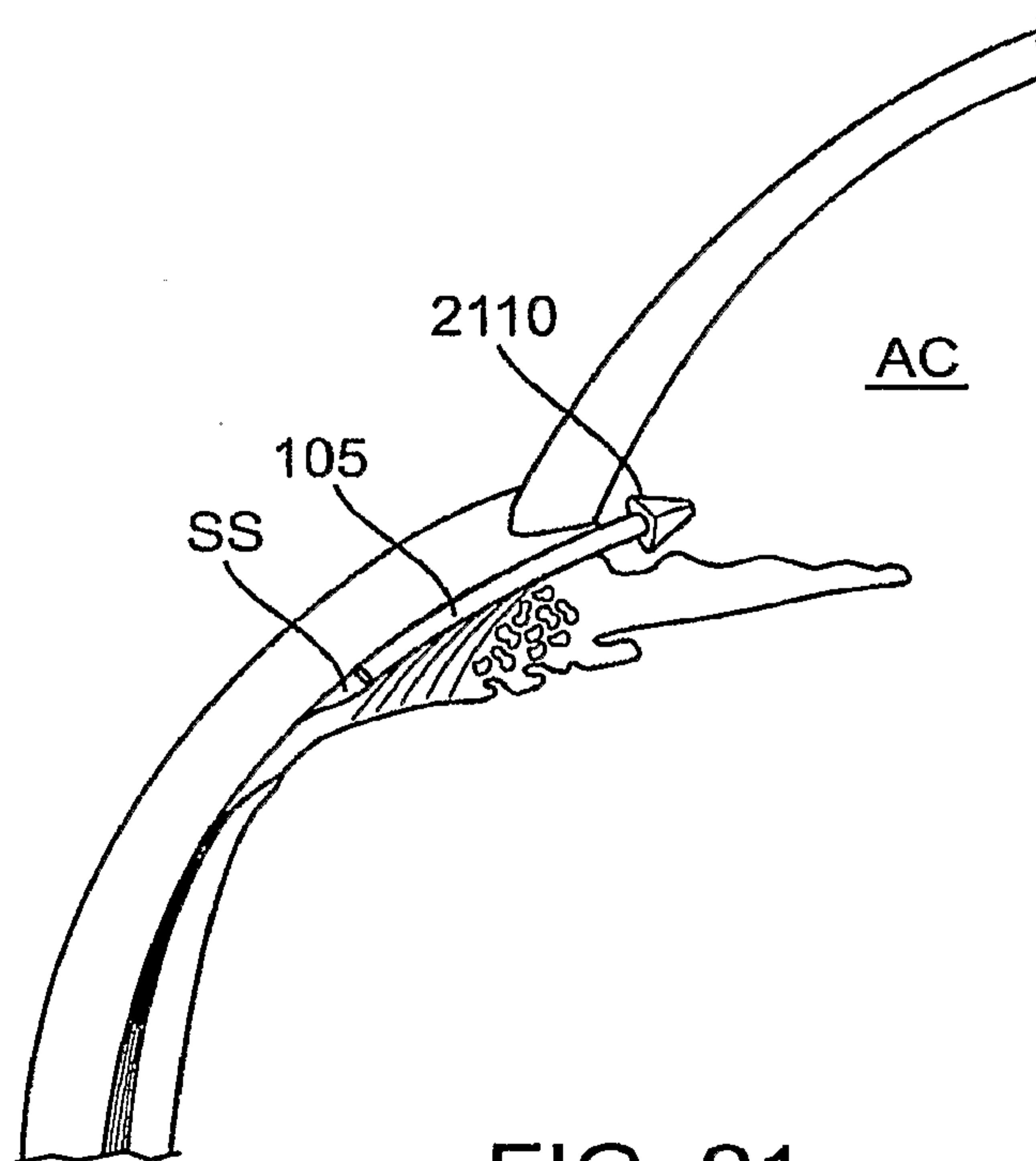

FIG. 21

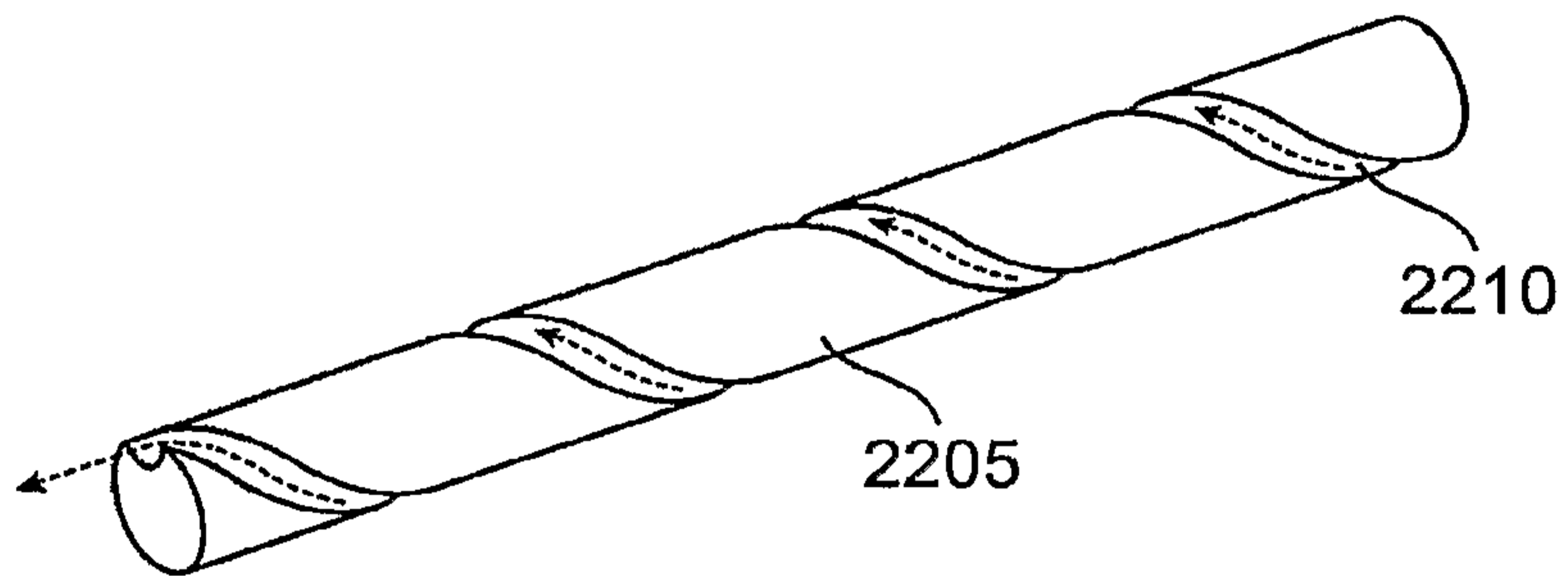

FIG. 22

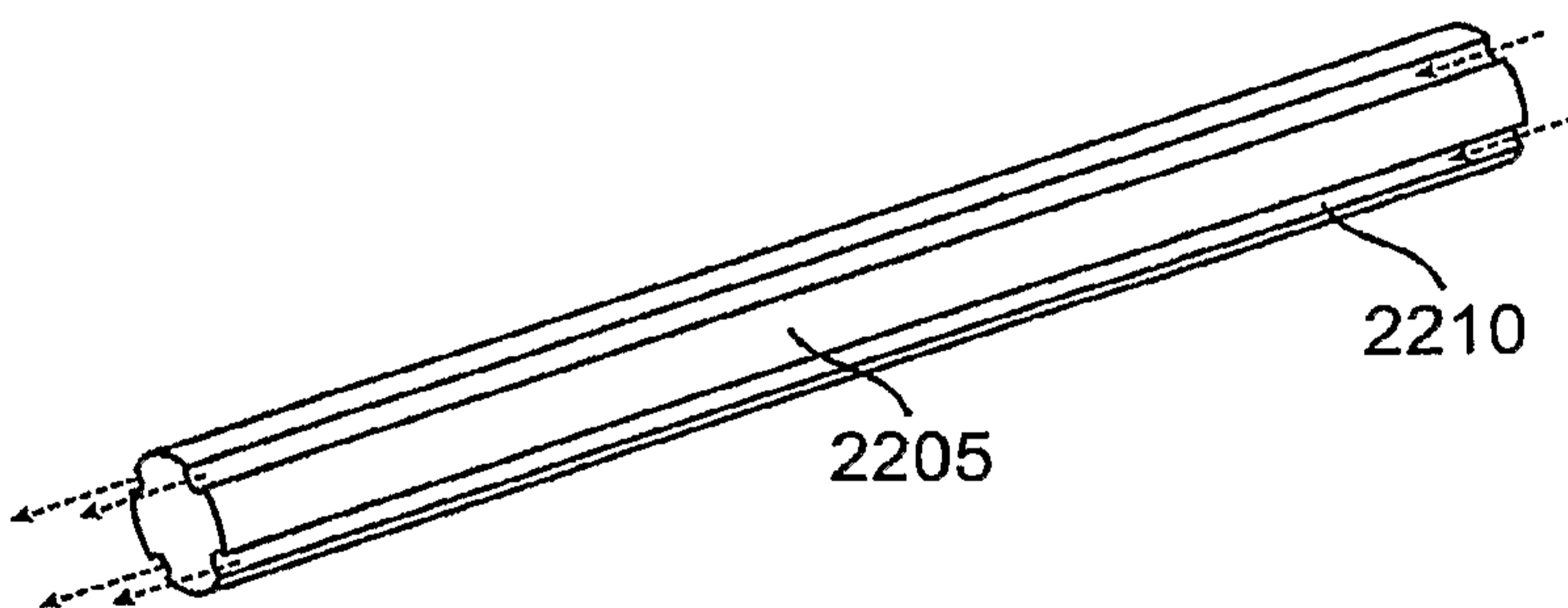

FIG. 23

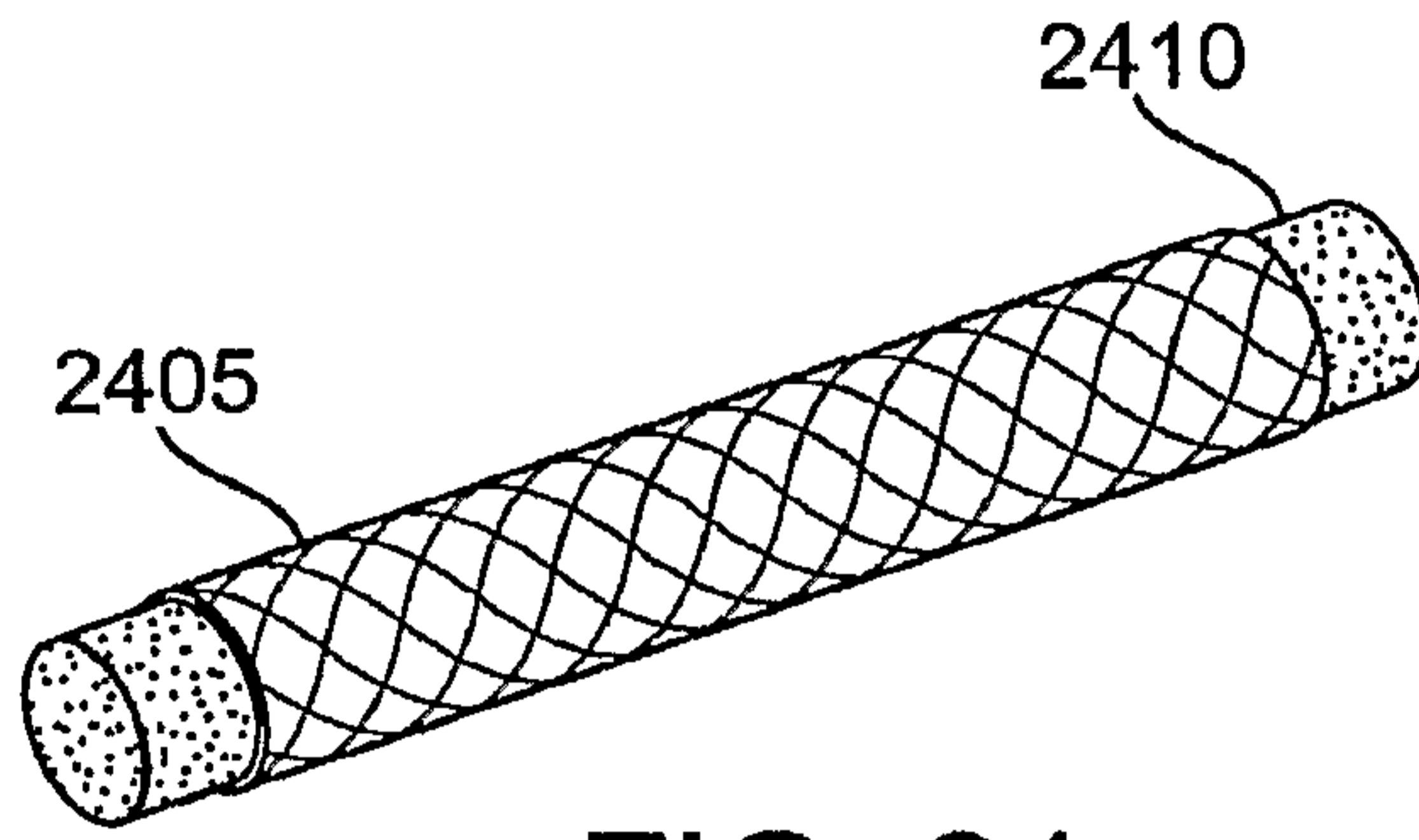

FIG. 24

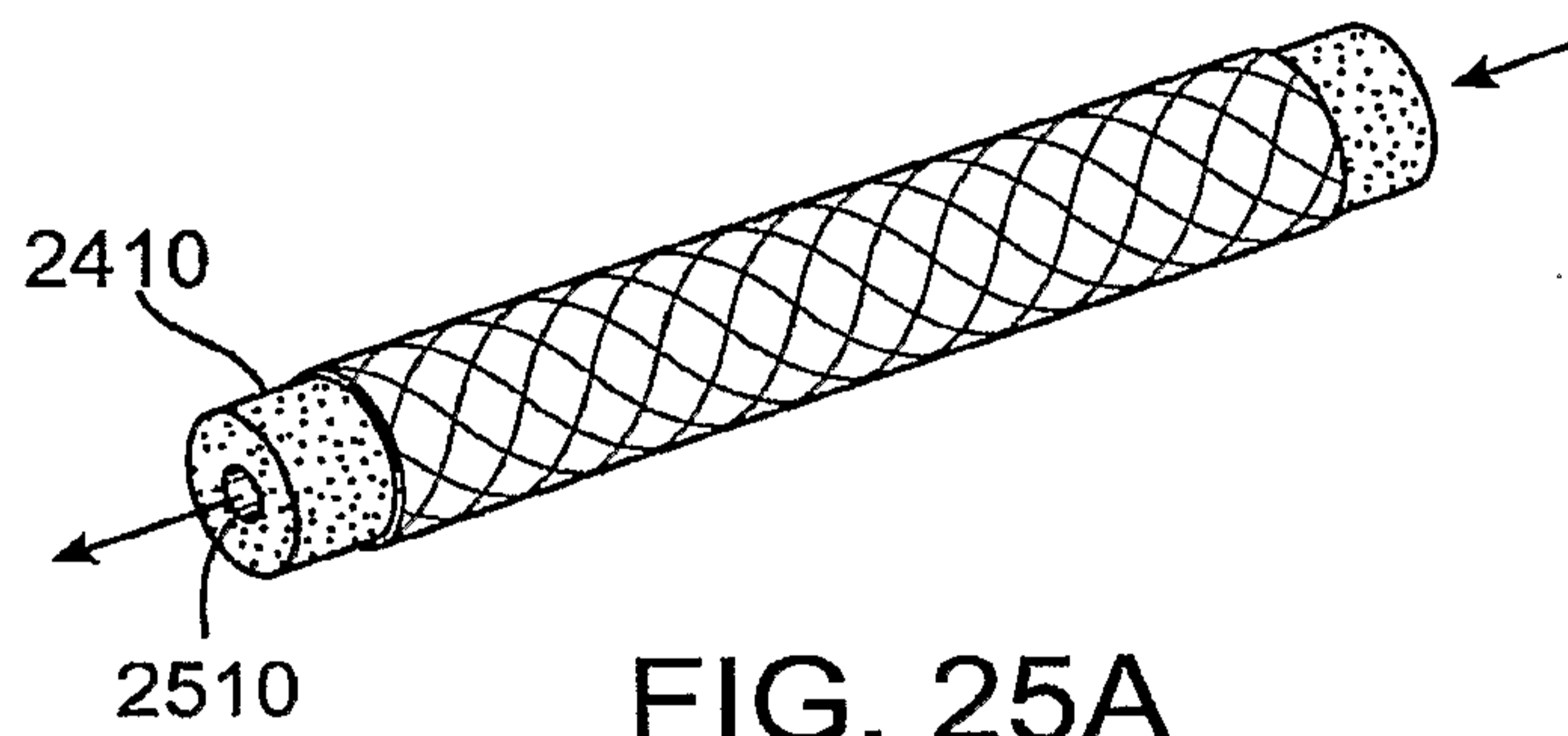

FIG. 25A

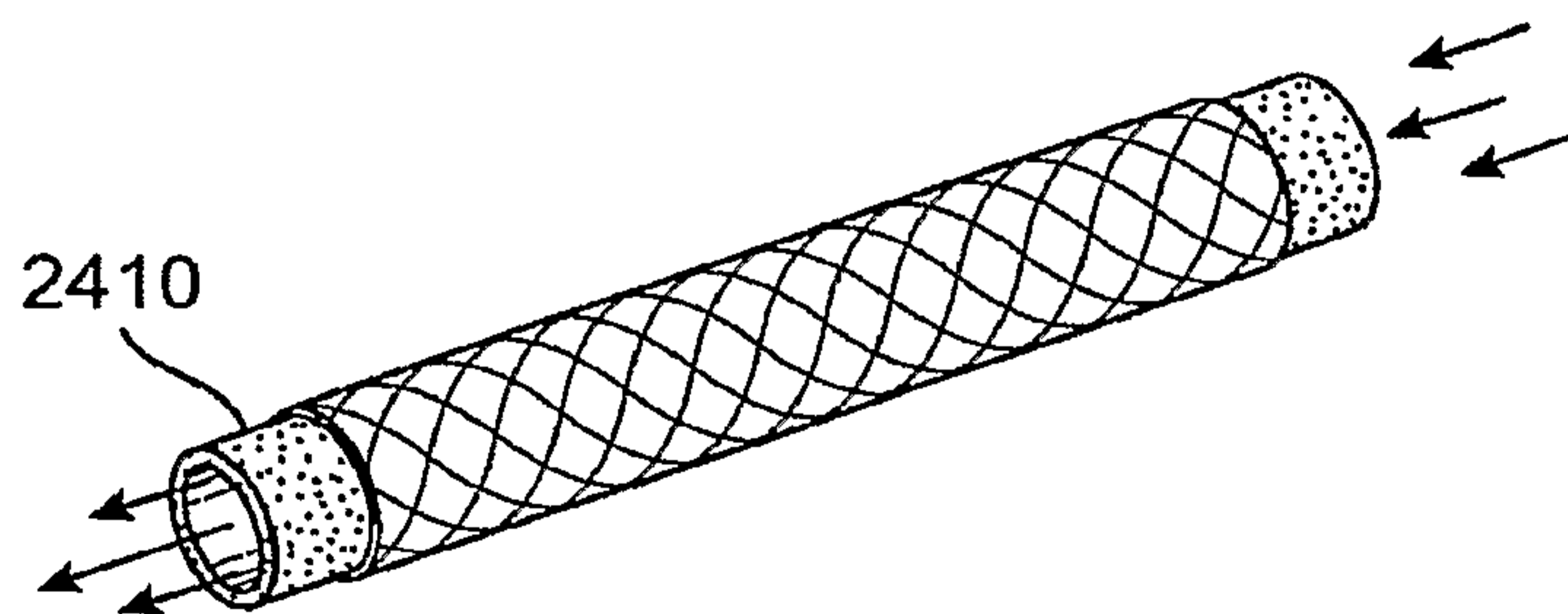

FIG. 25B

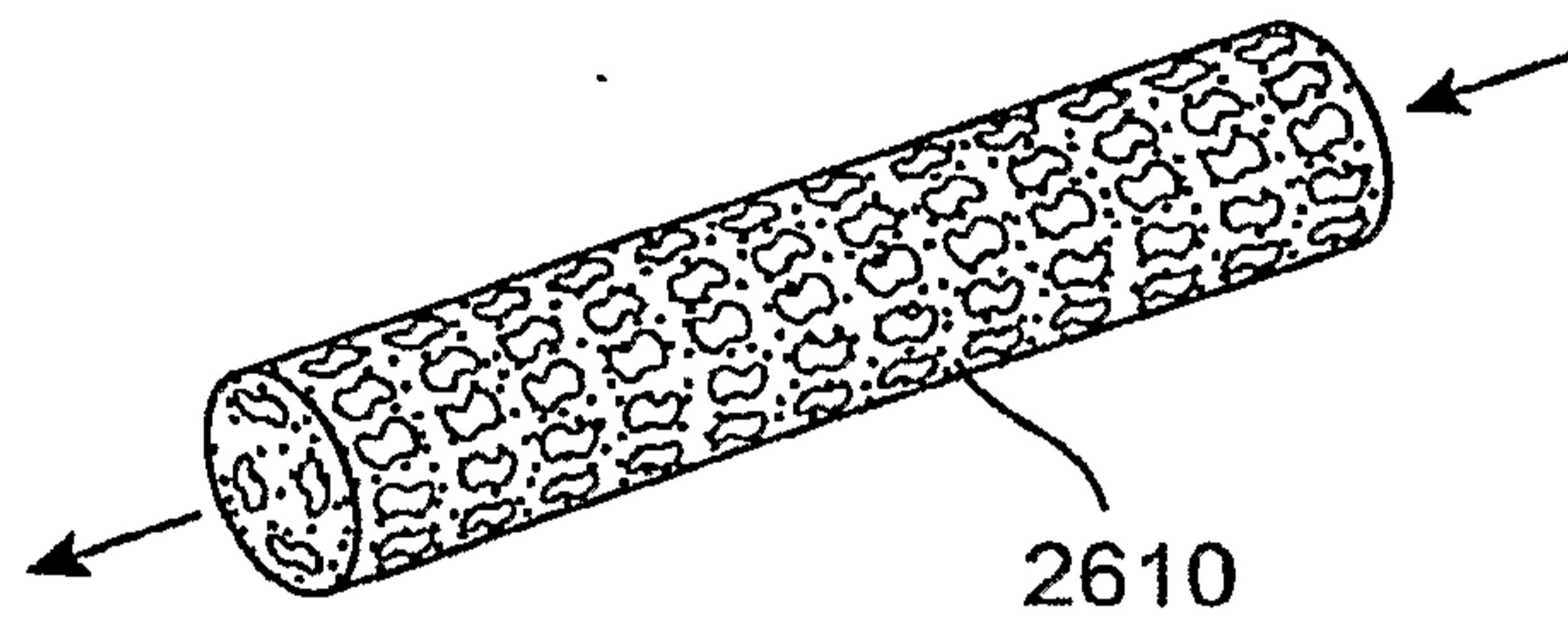

FIG. 26

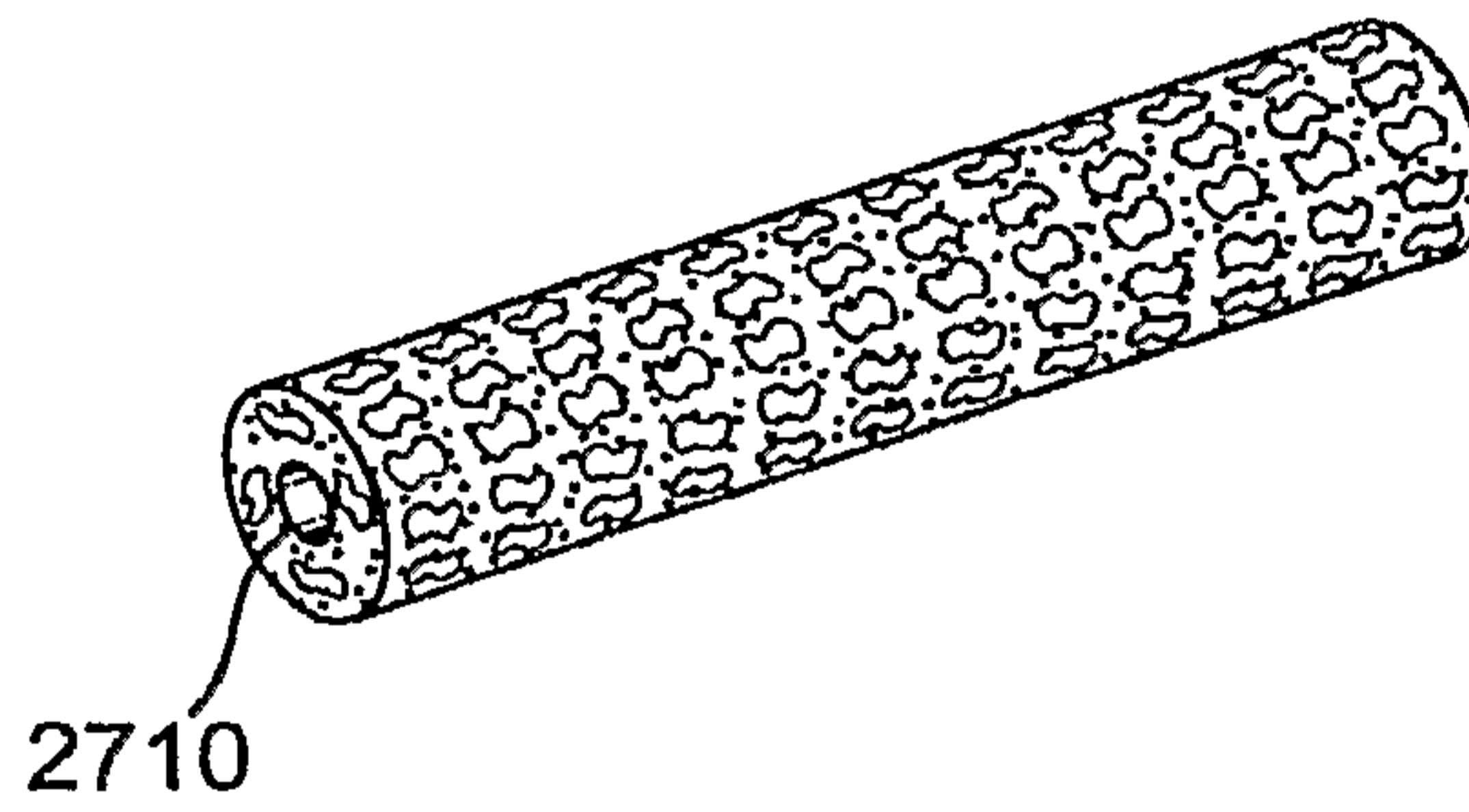

FIG. 27

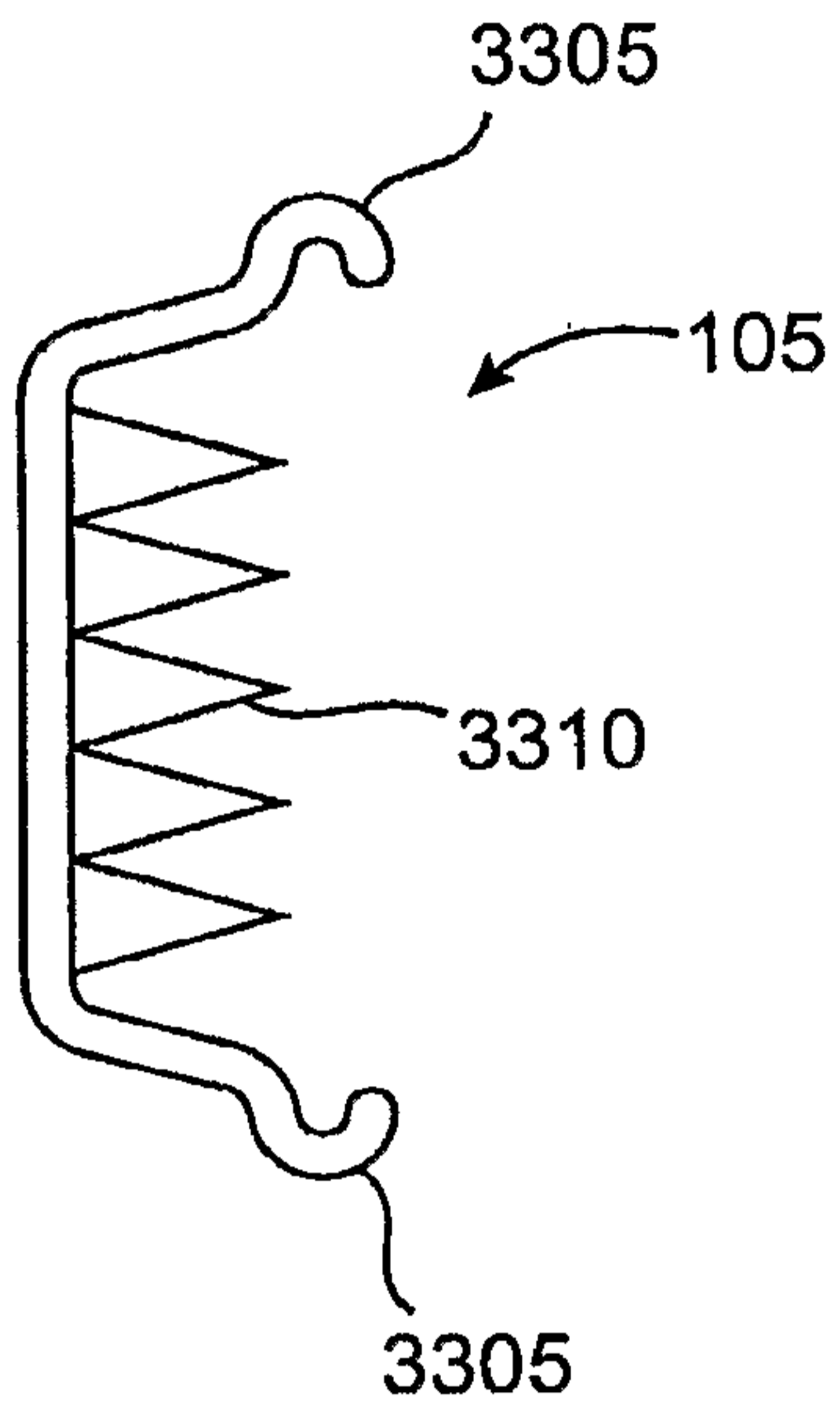

FIG. 28

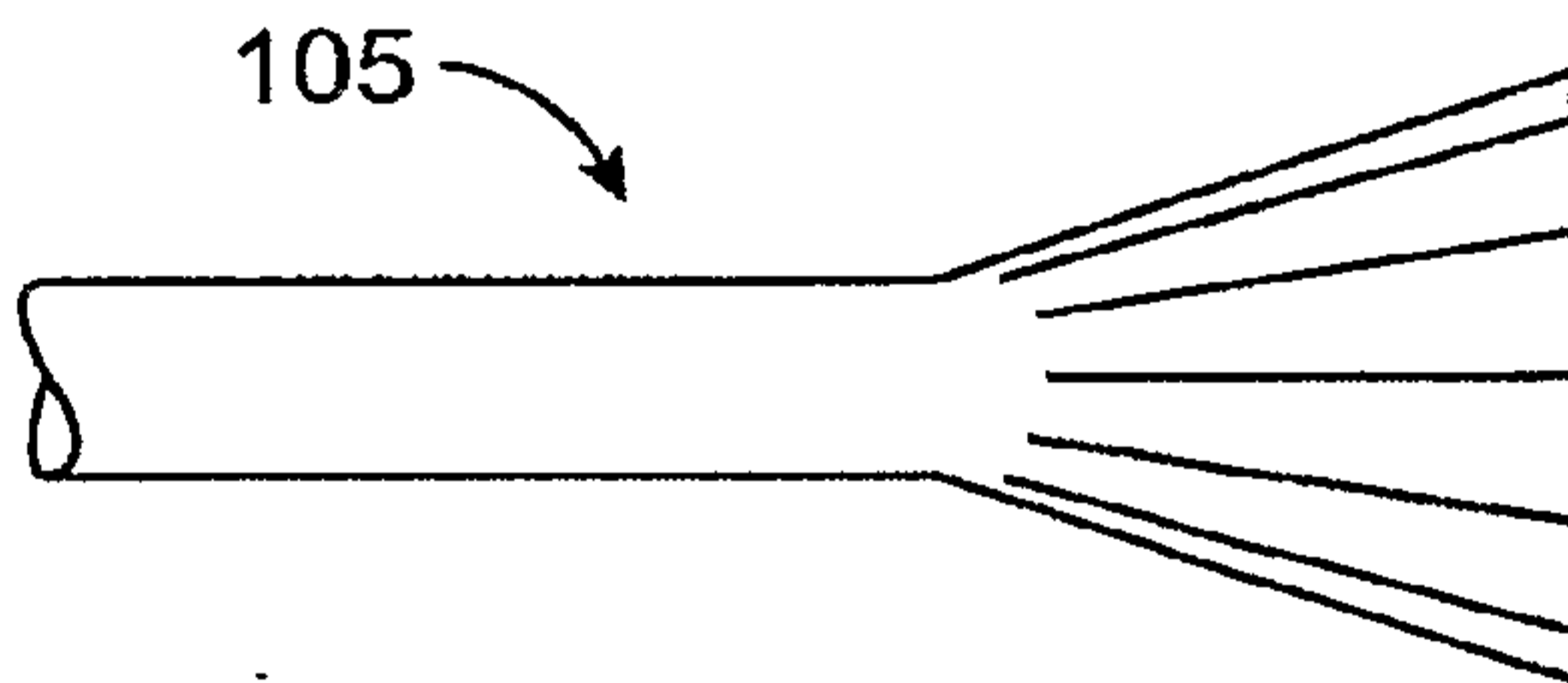

FIG. 29

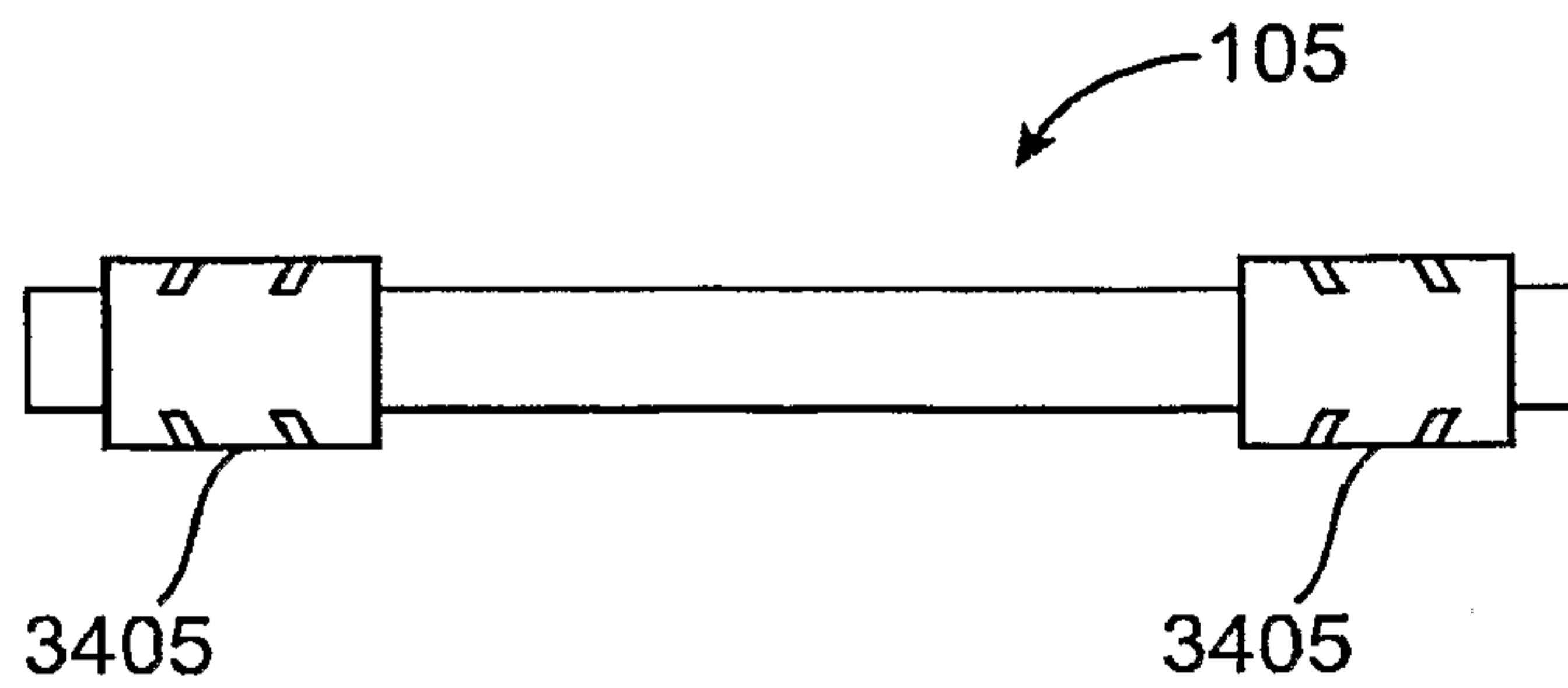

FIG. 30

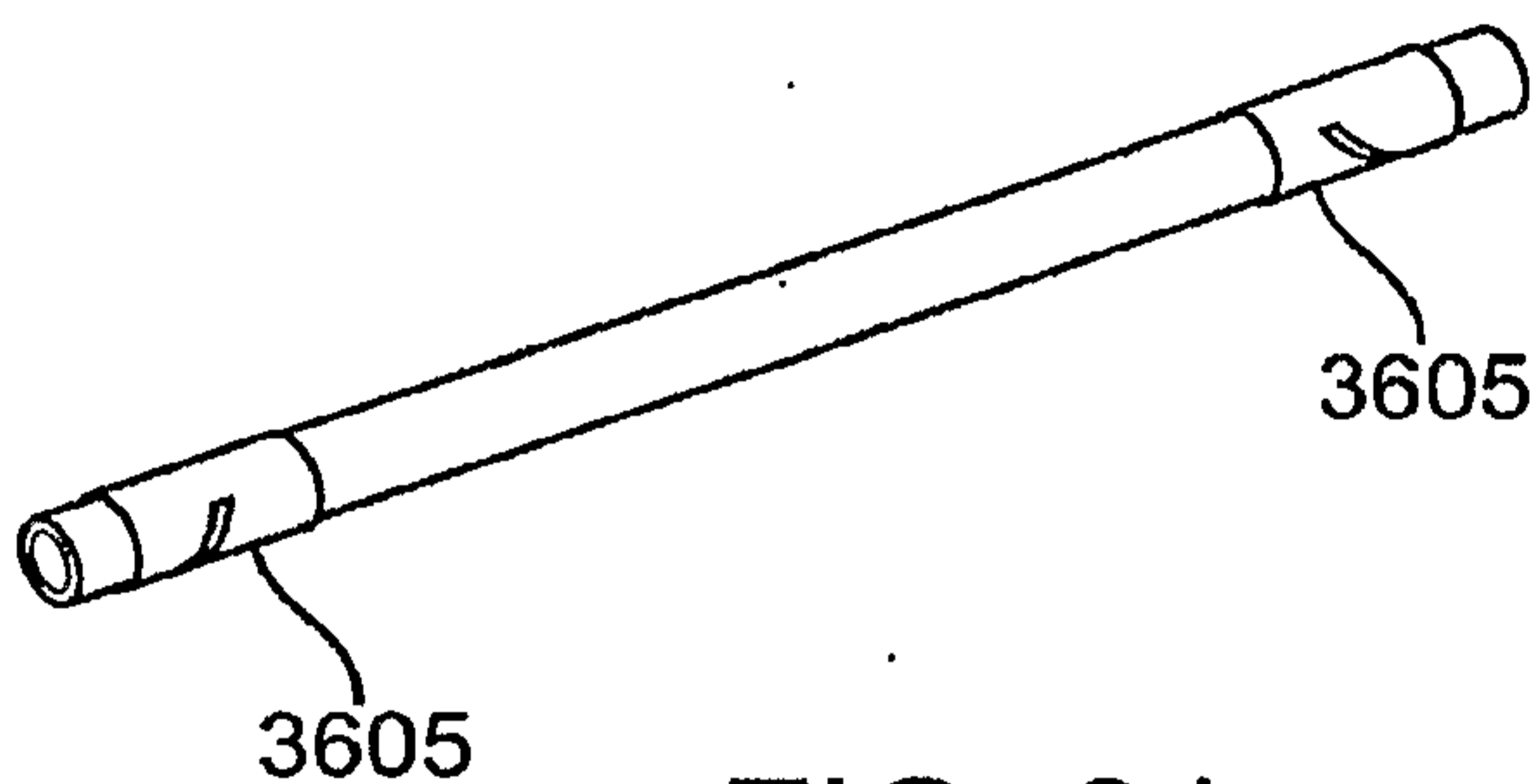

FIG. 31

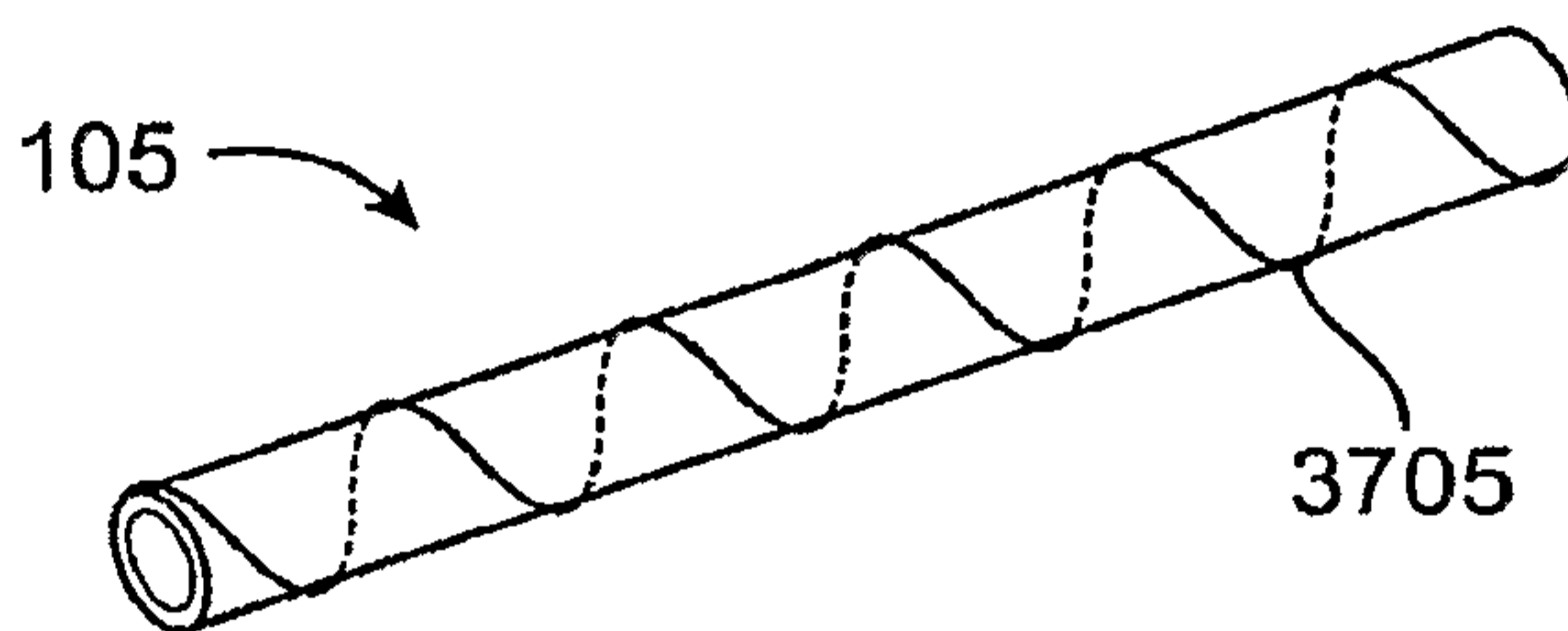

FIG. 32

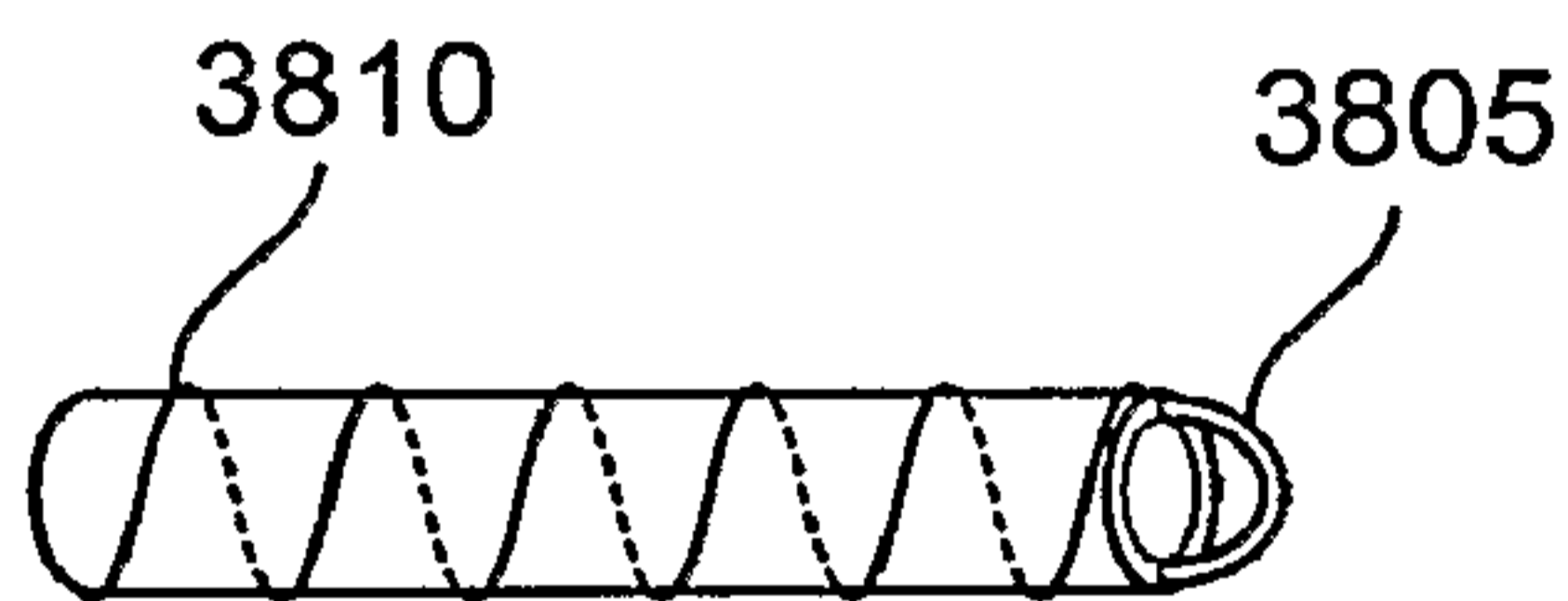

FIG. 33A

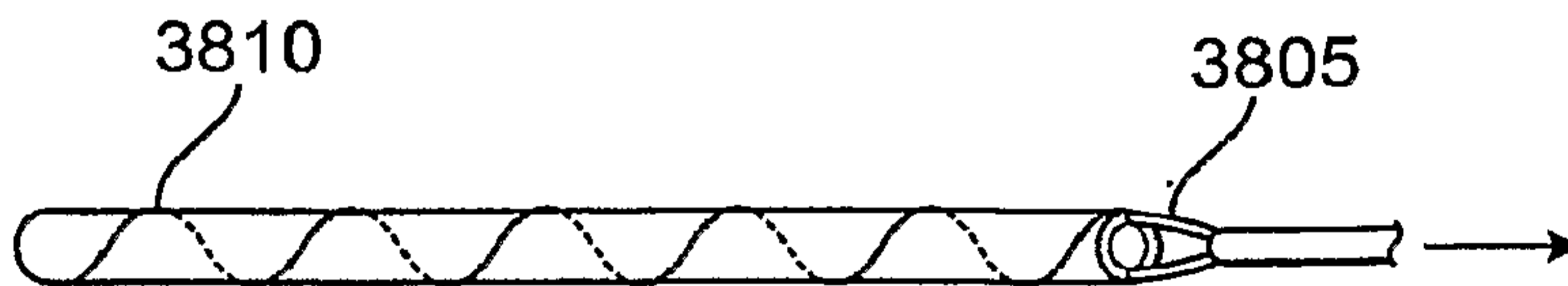

FIG. 33B



FIG. 34

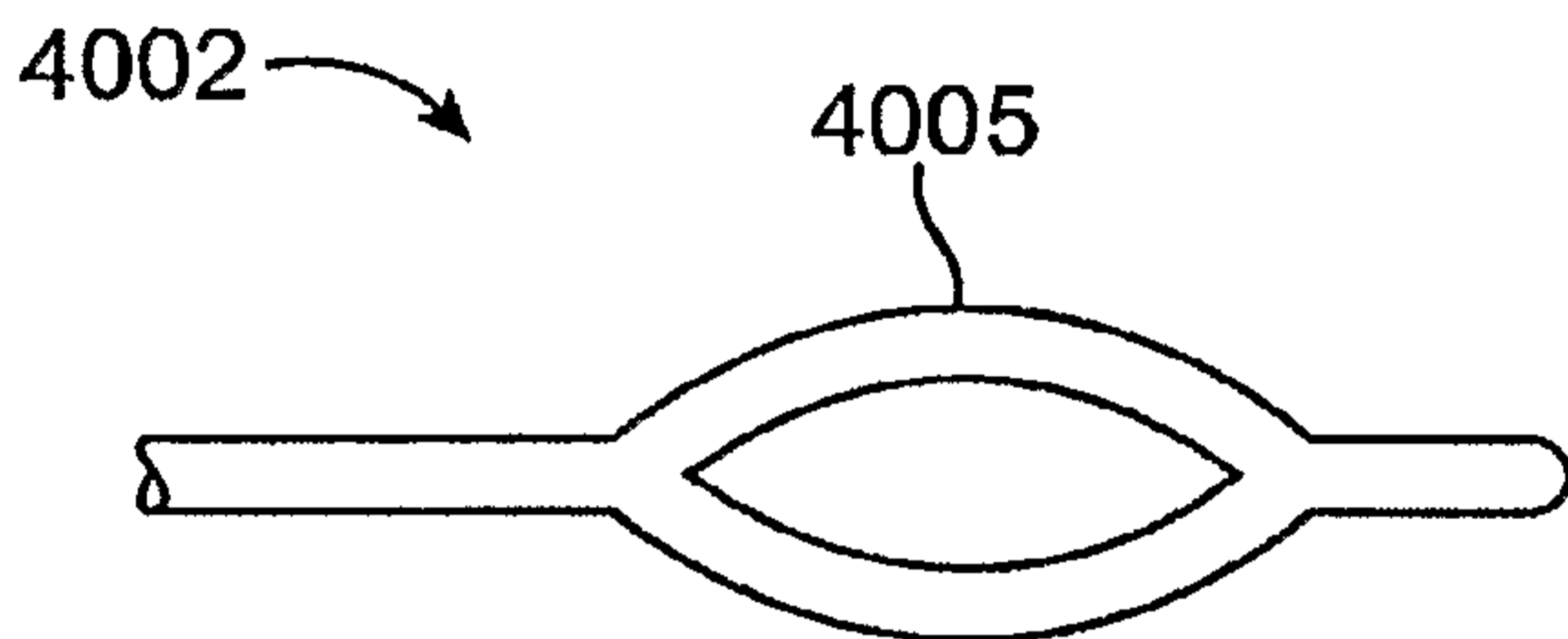

FIG. 35



FIG. 36



FIG. 37

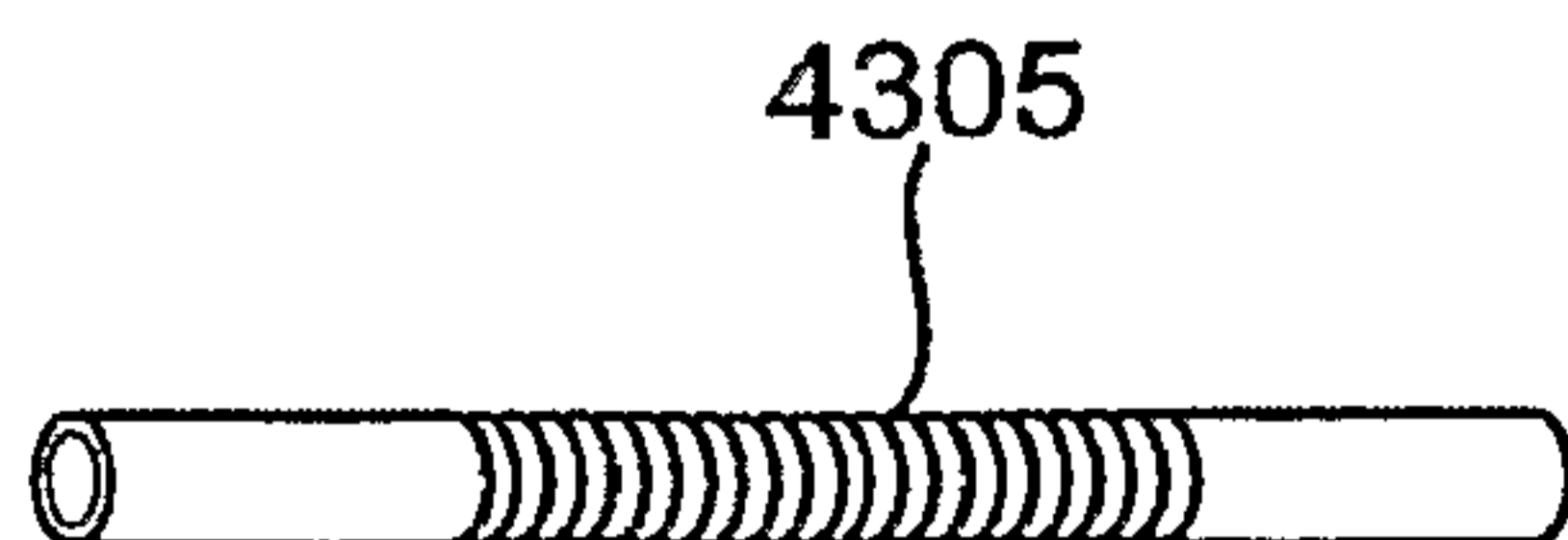

FIG. 38

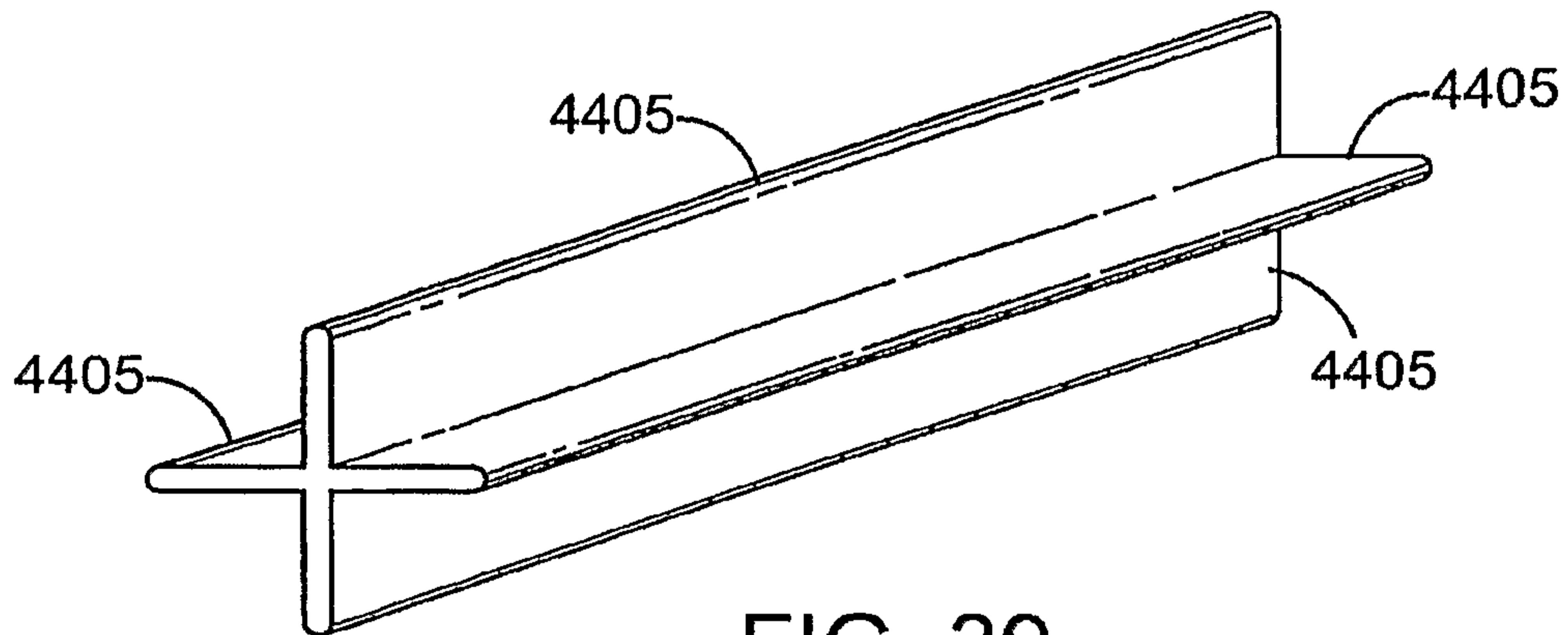

FIG. 39

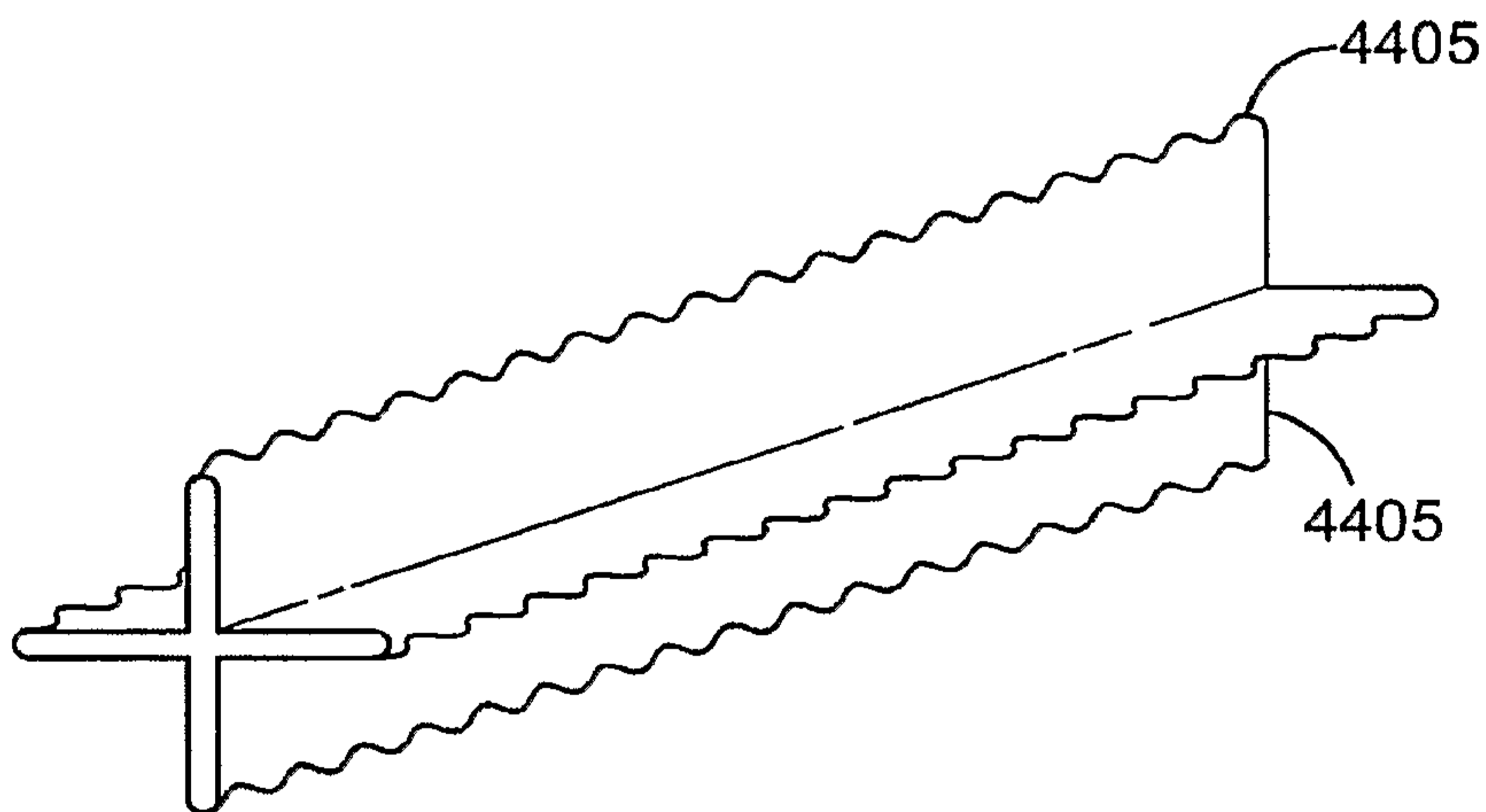

FIG. 40A

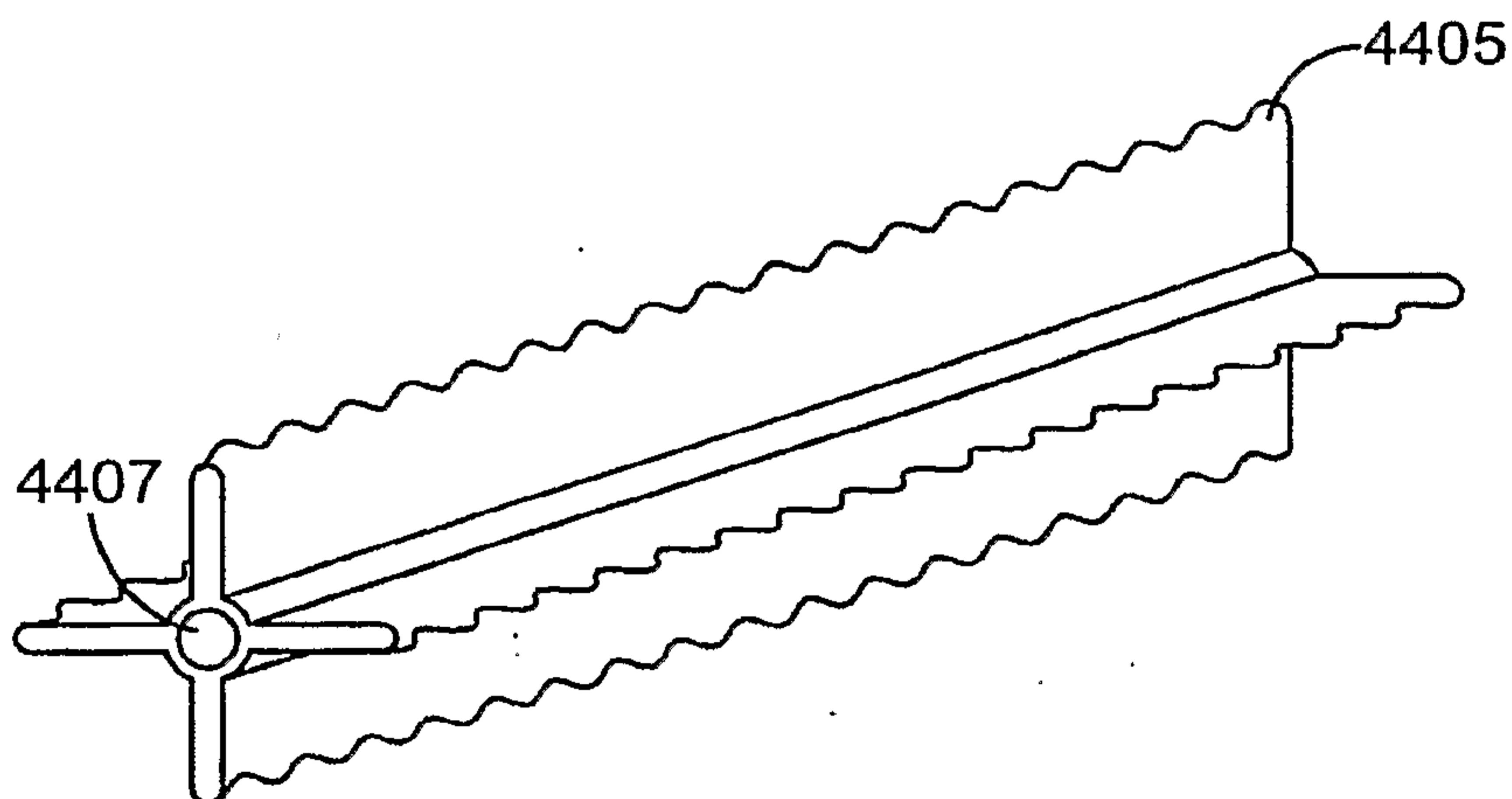

FIG. 40B

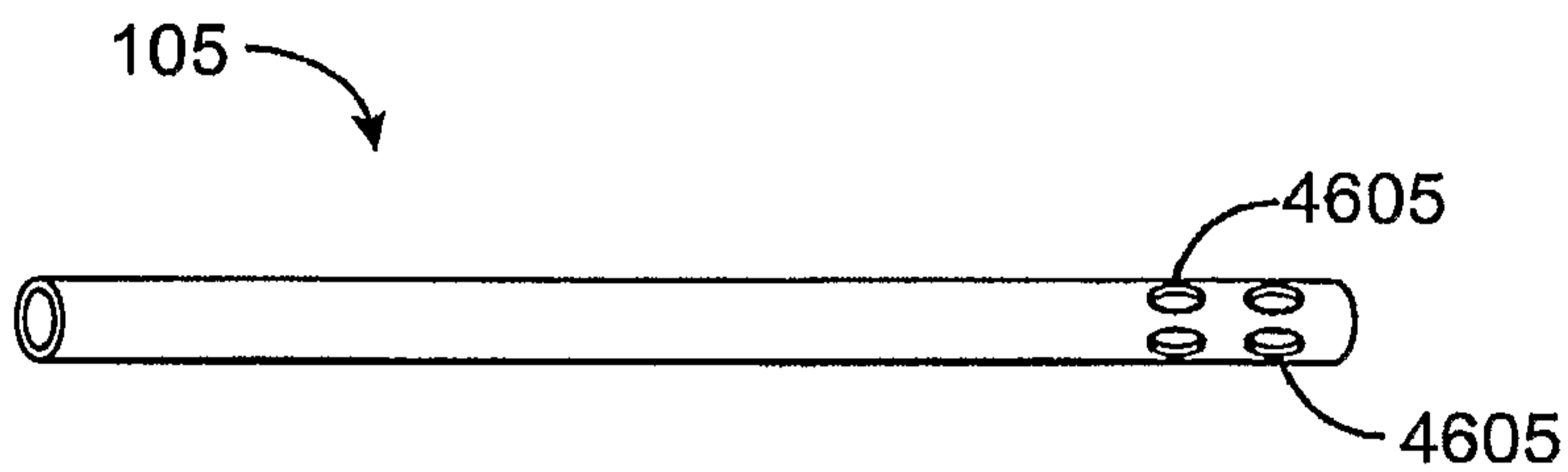

FIG. 41

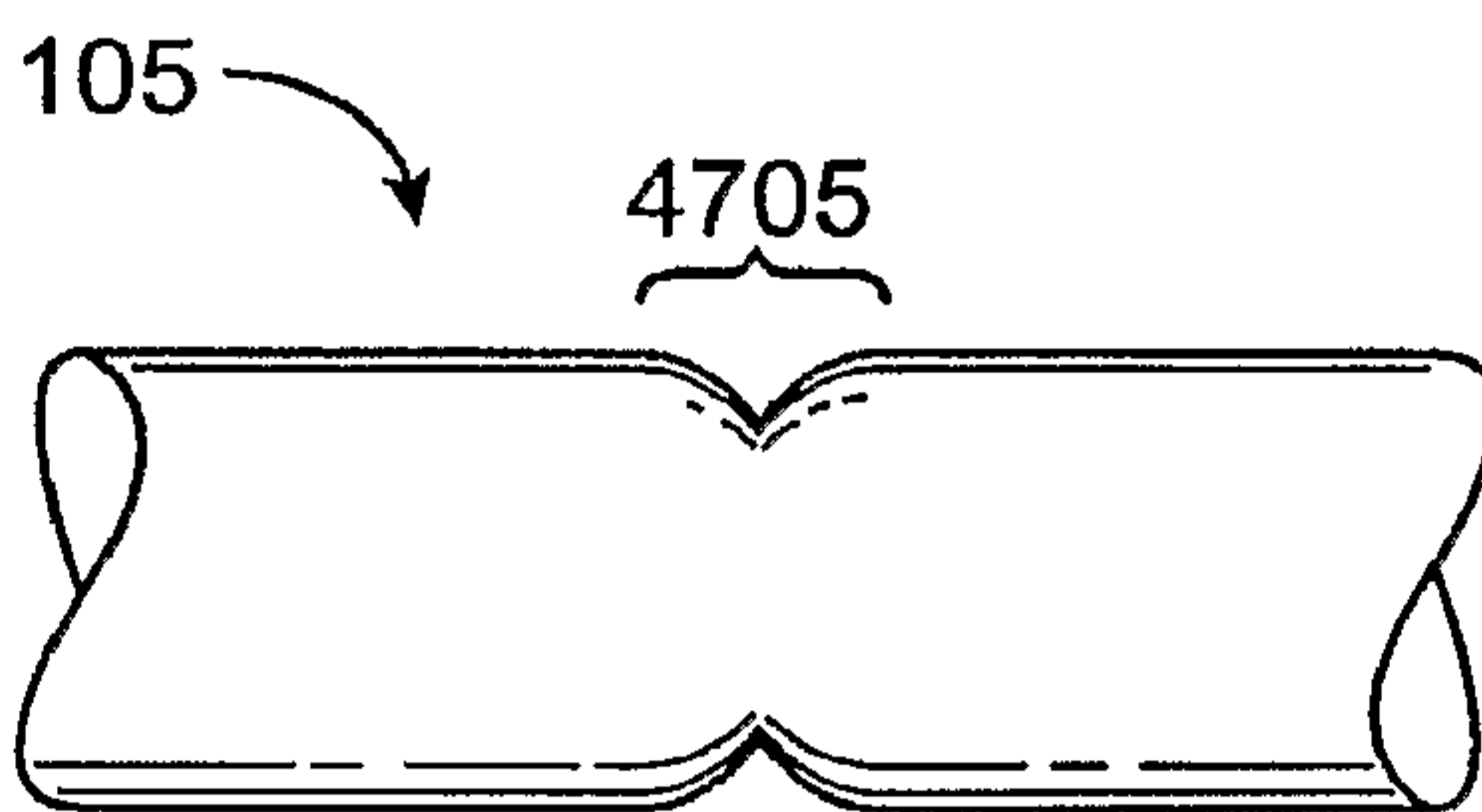

FIG. 42A

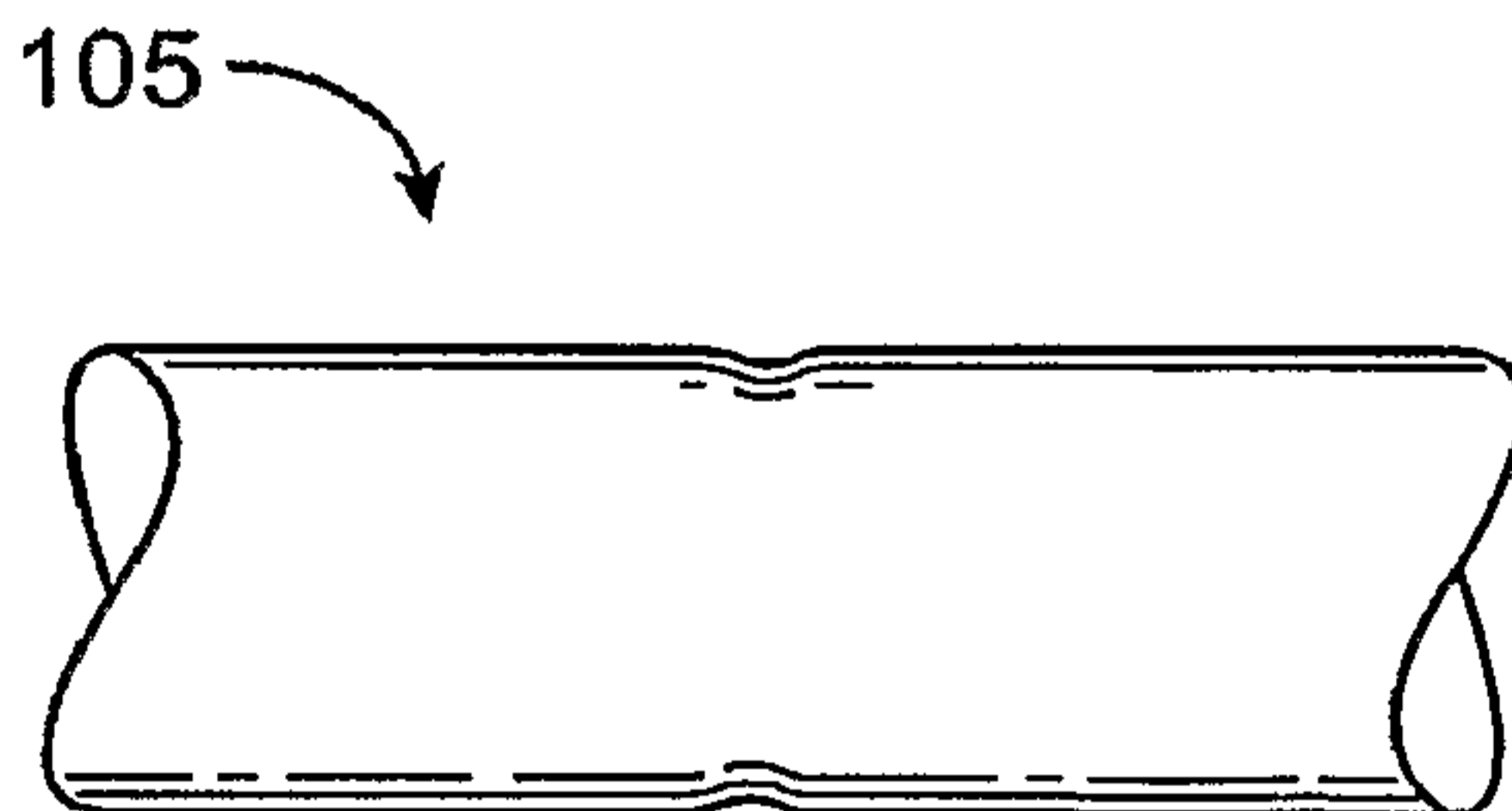

FIG. 42B

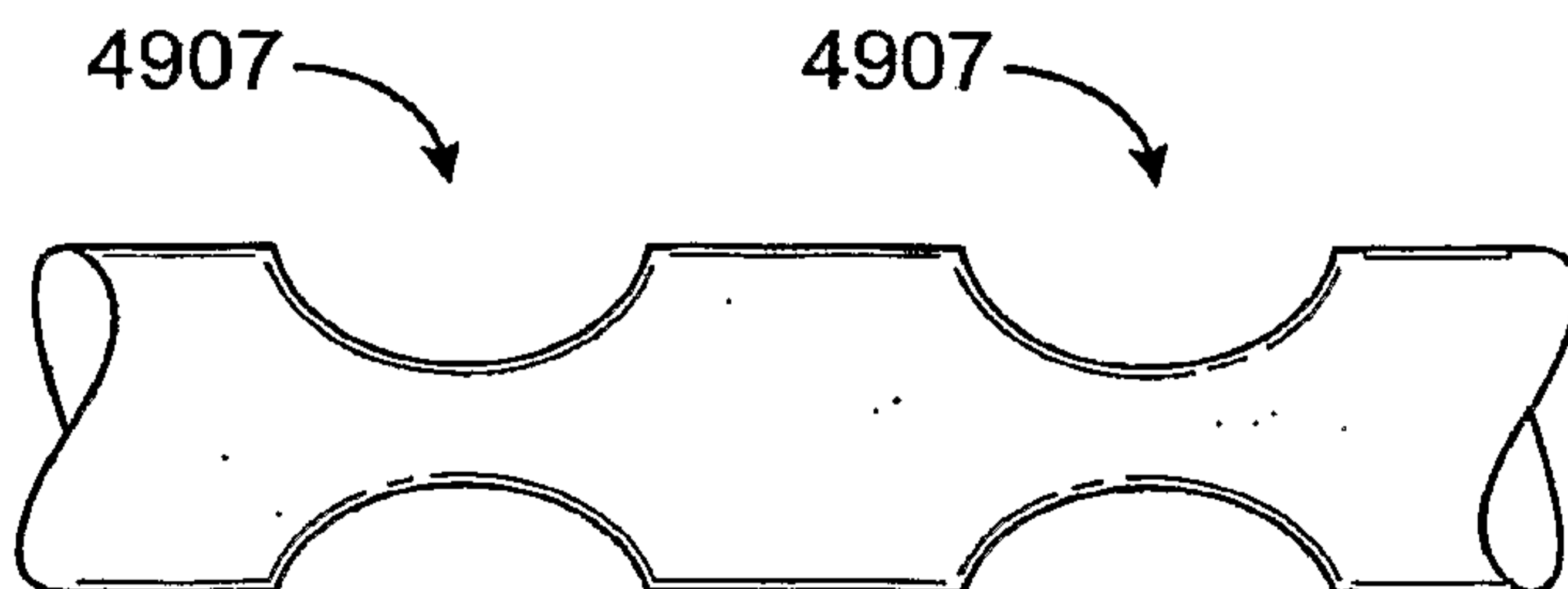

FIG. 43

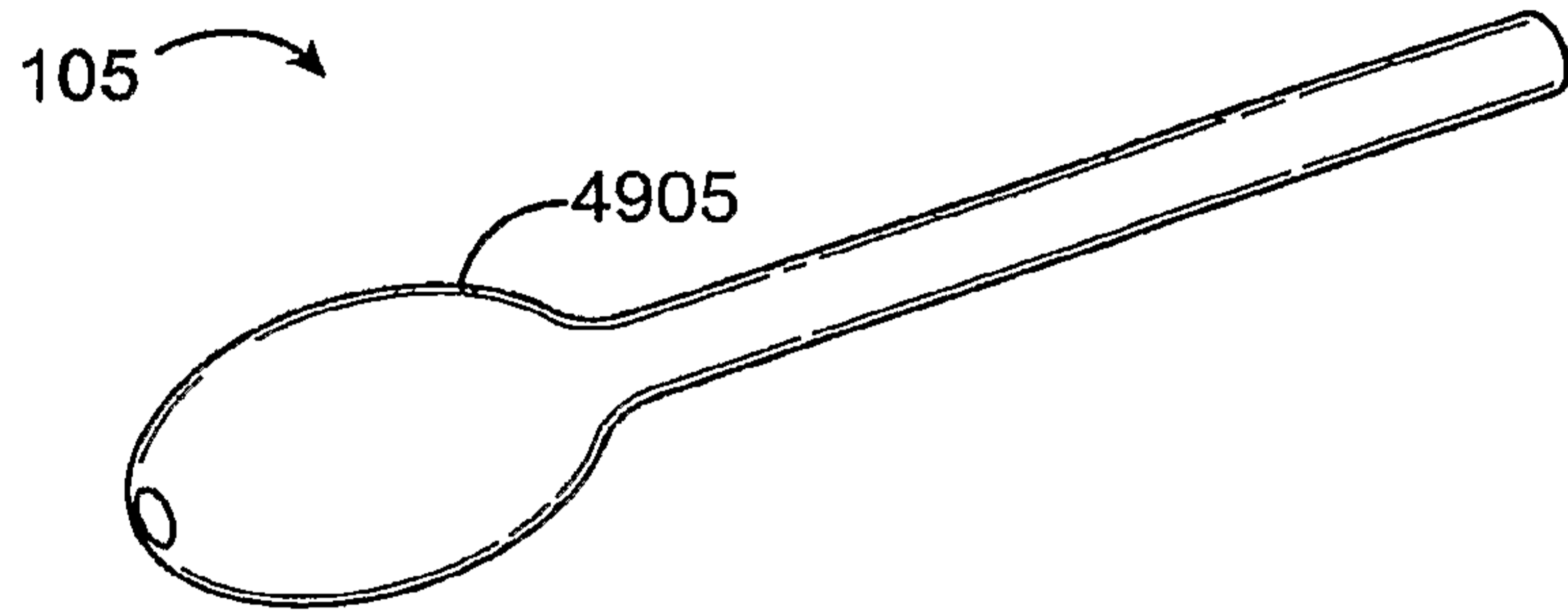

FIG. 44

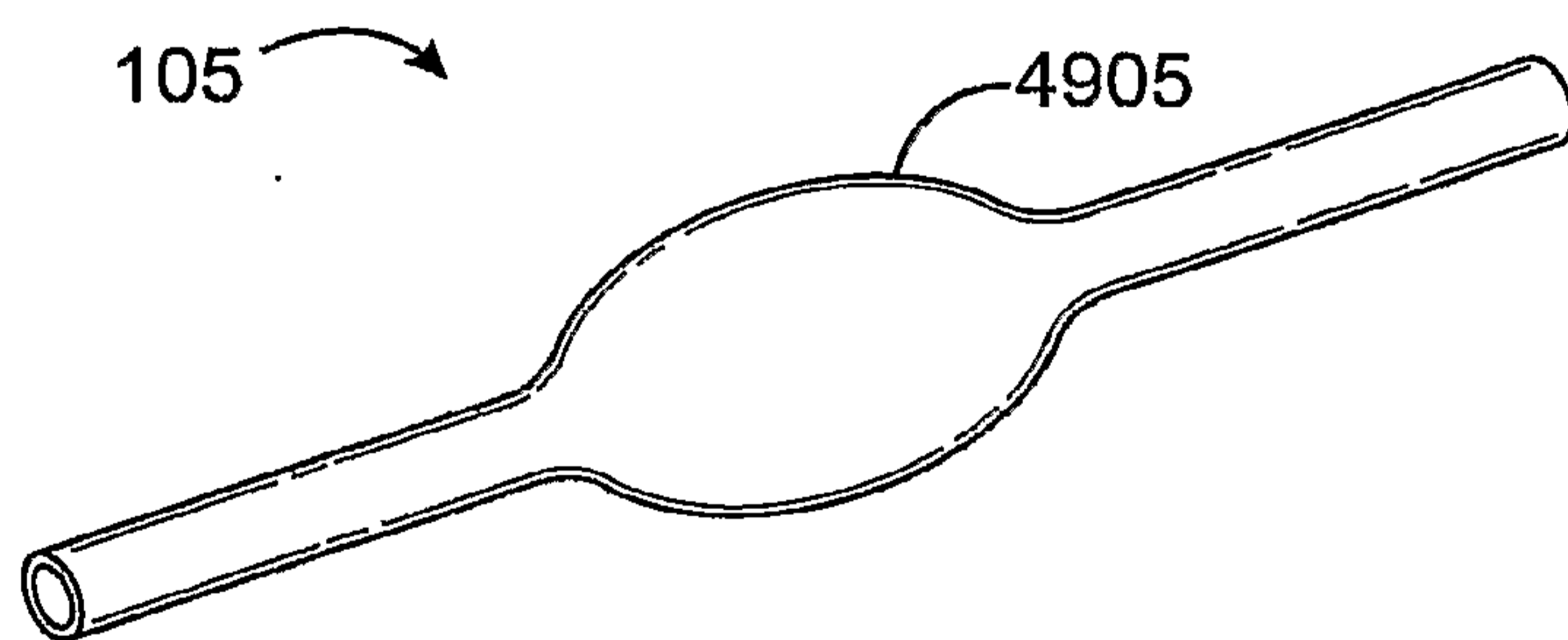
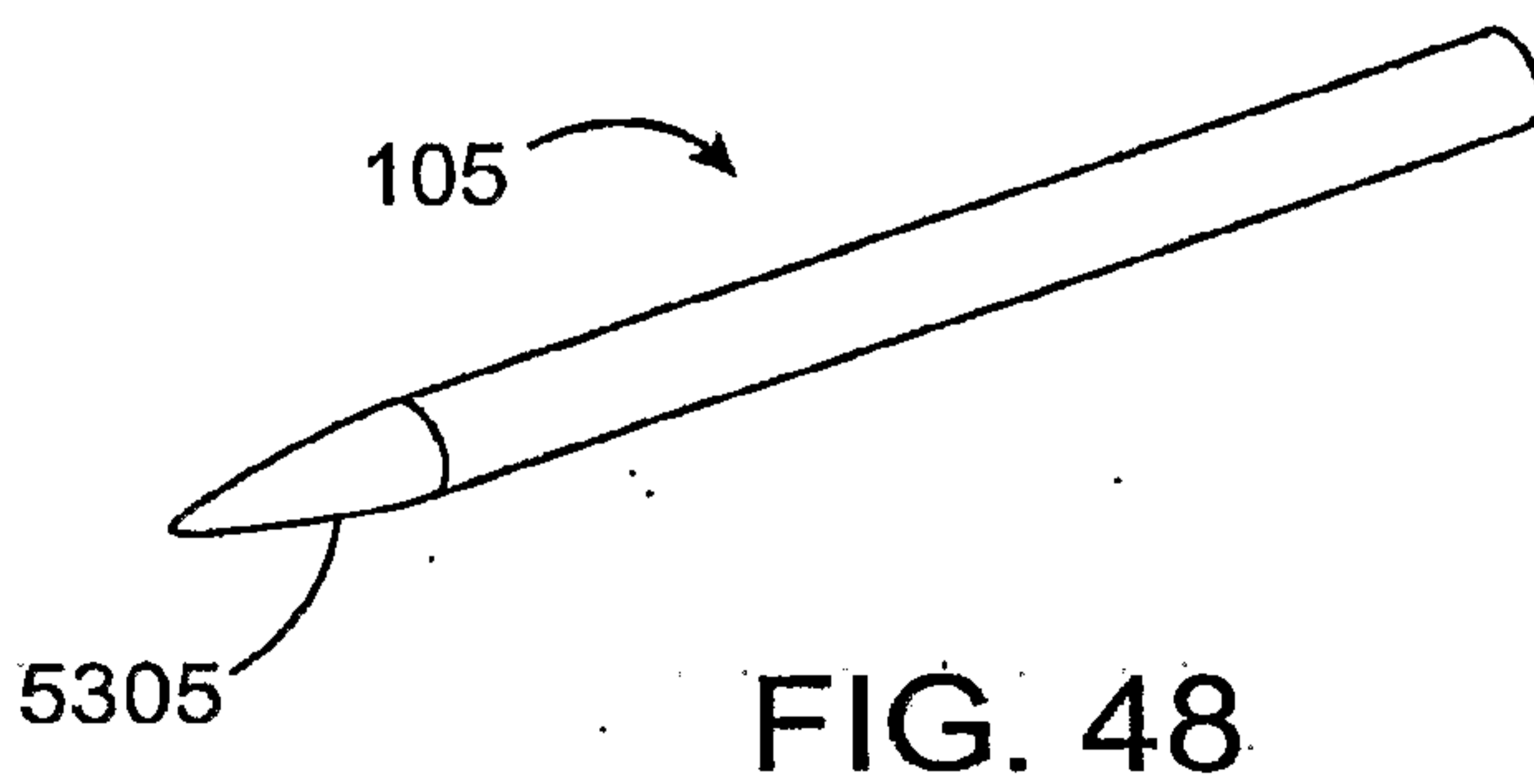
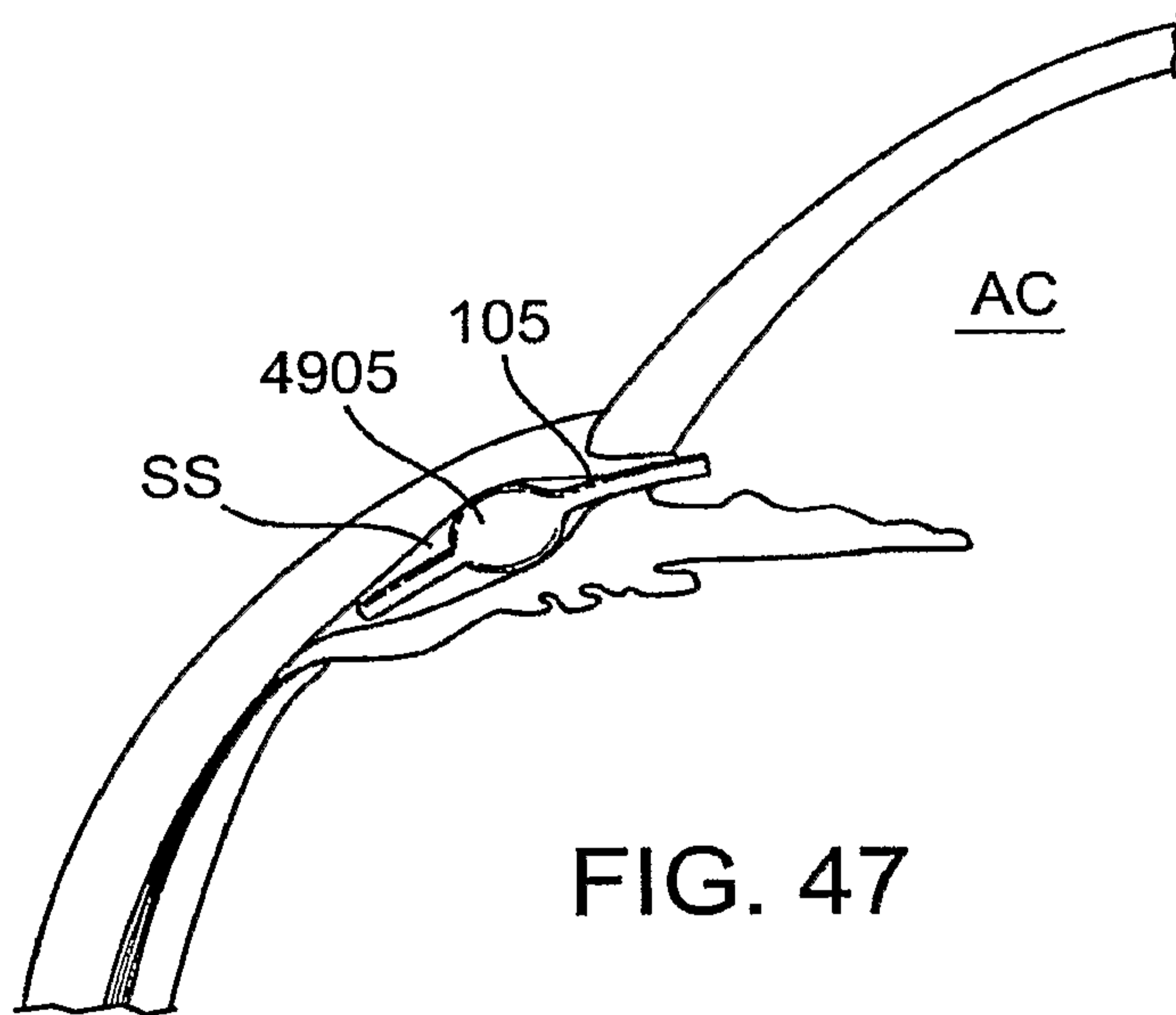
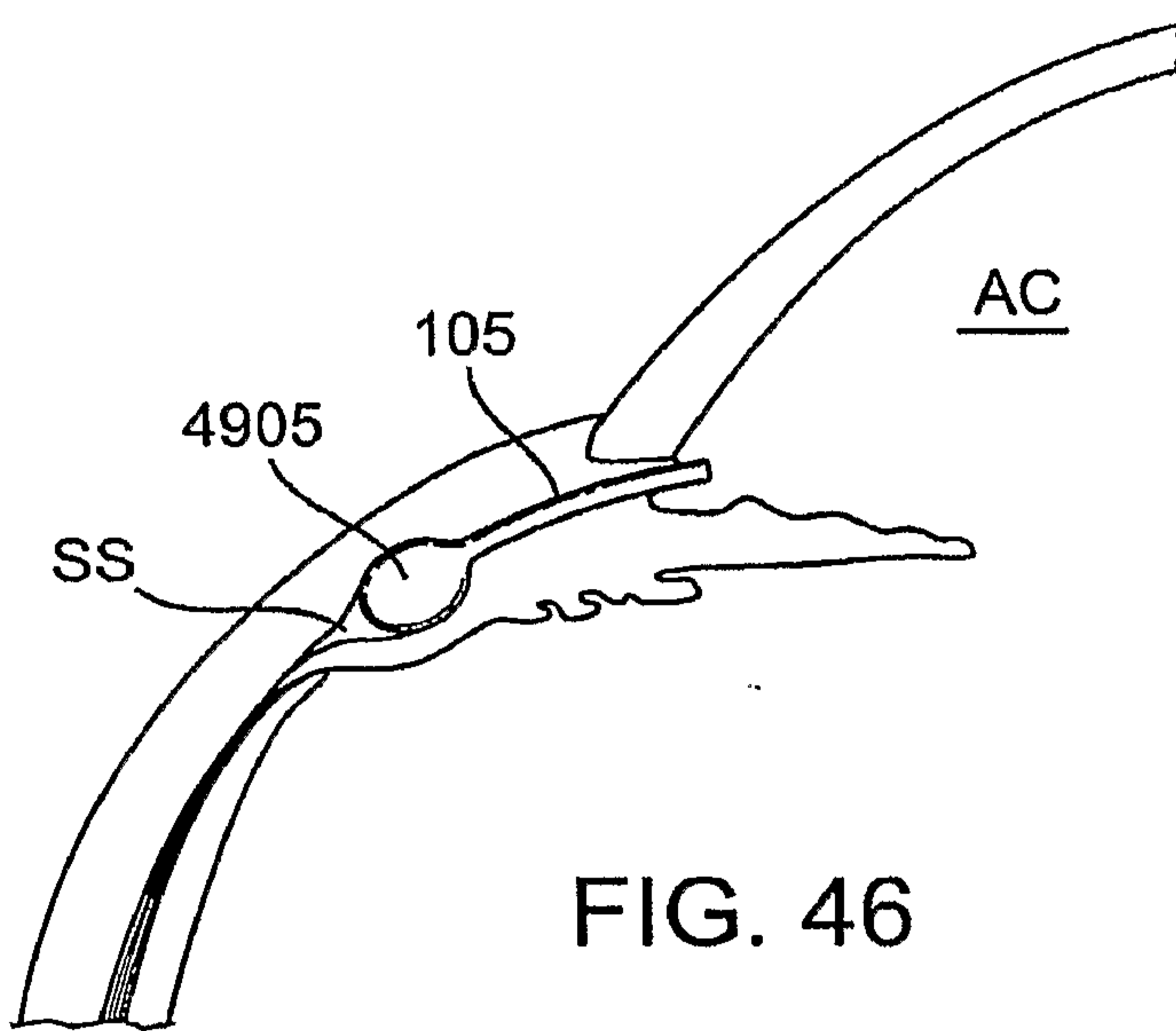

FIG. 45



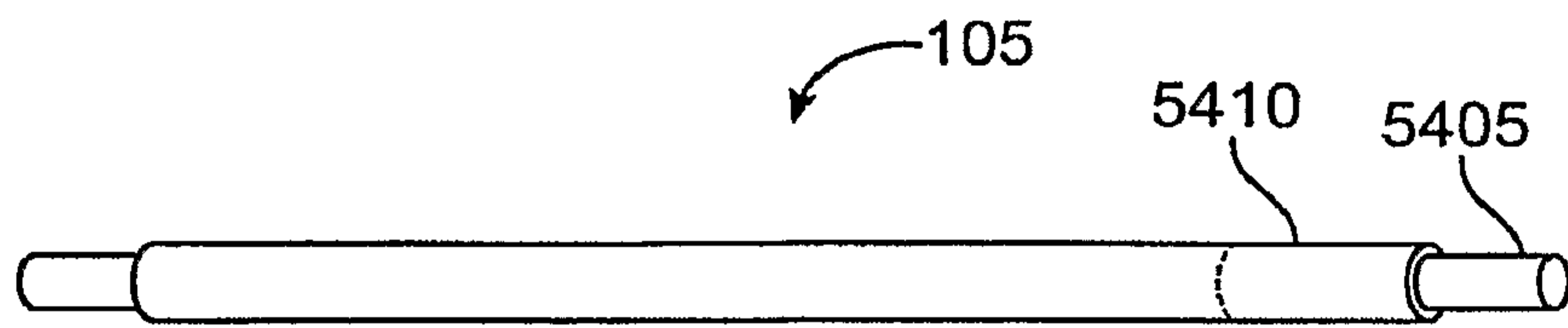

FIG. 49

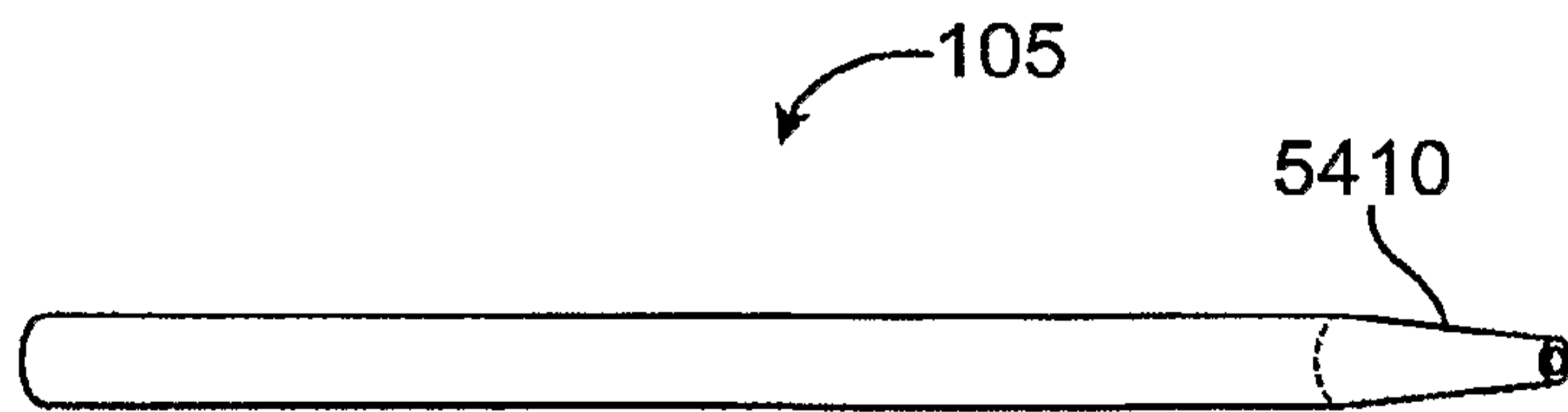

FIG. 50

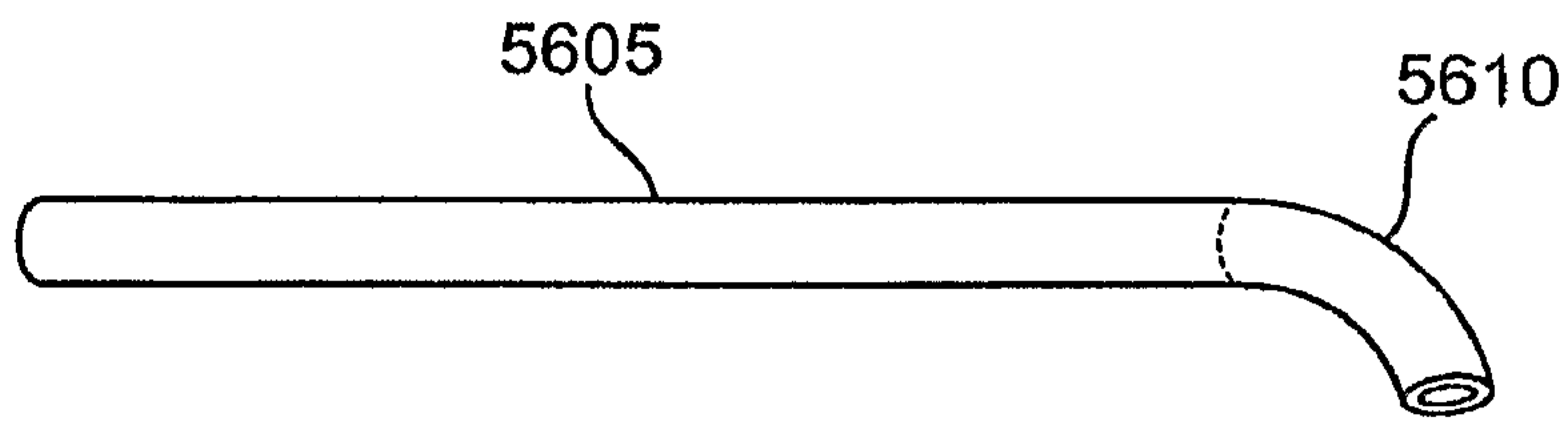

FIG. 51A

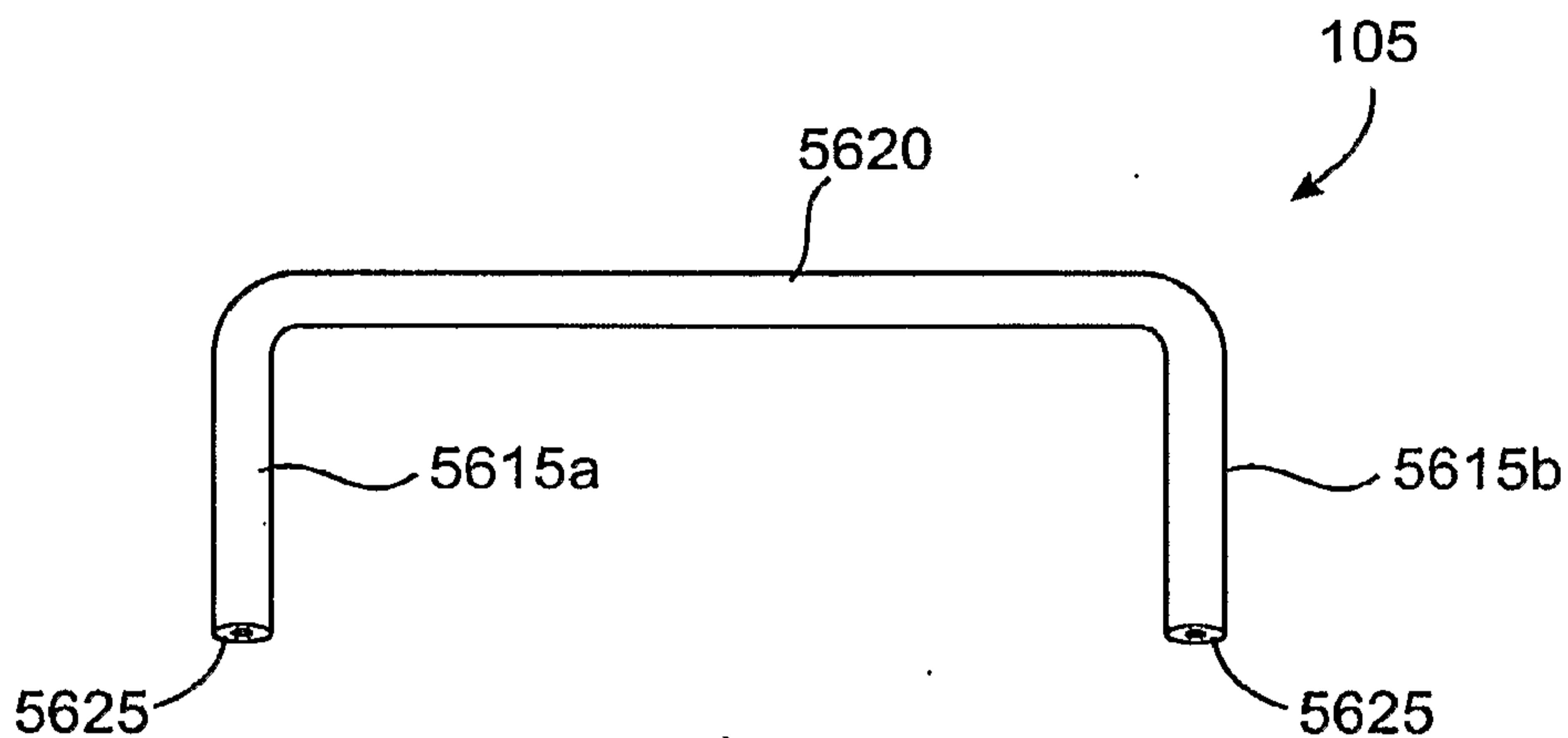

FIG. 51B

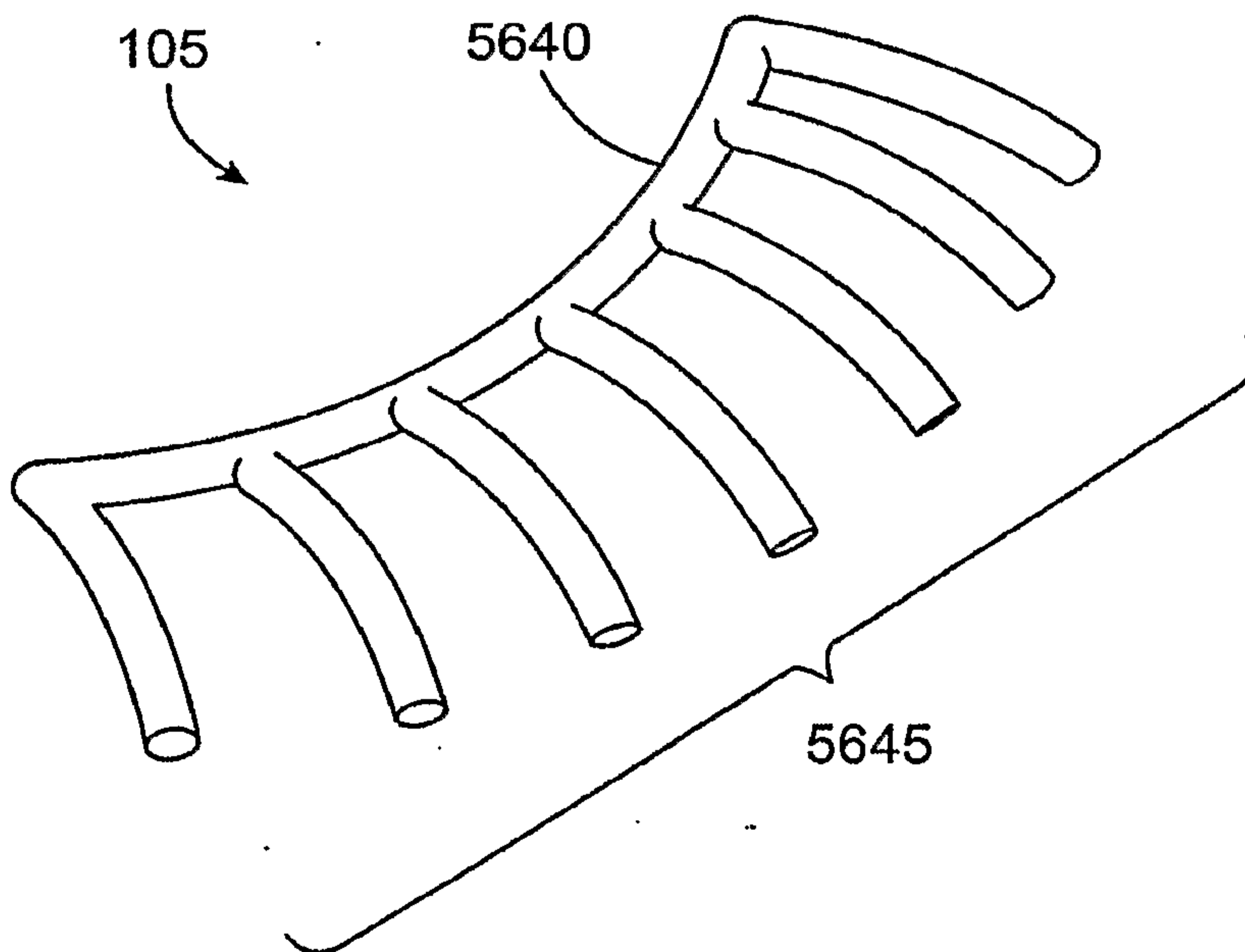

FIG. 51C

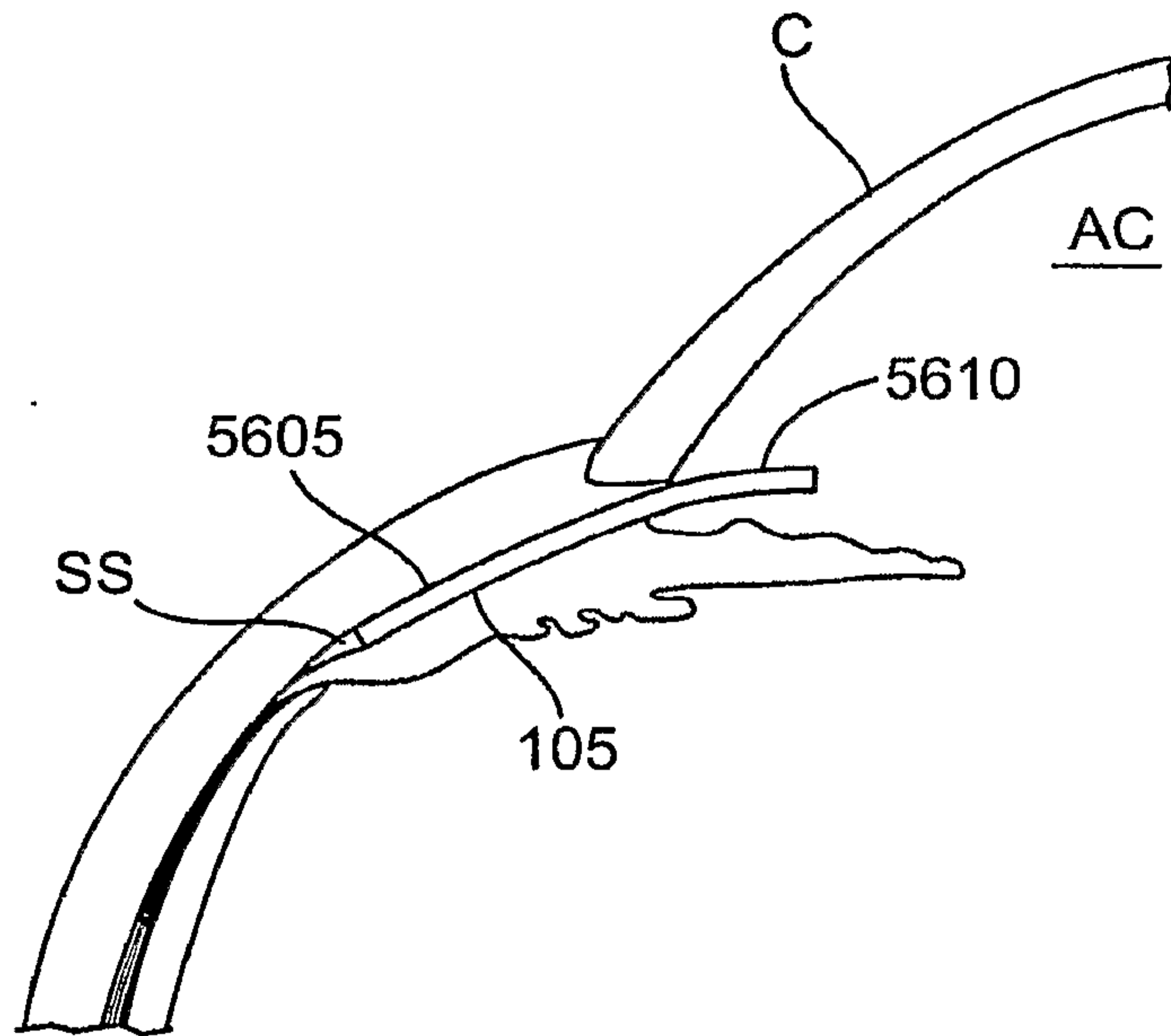

FIG. 52

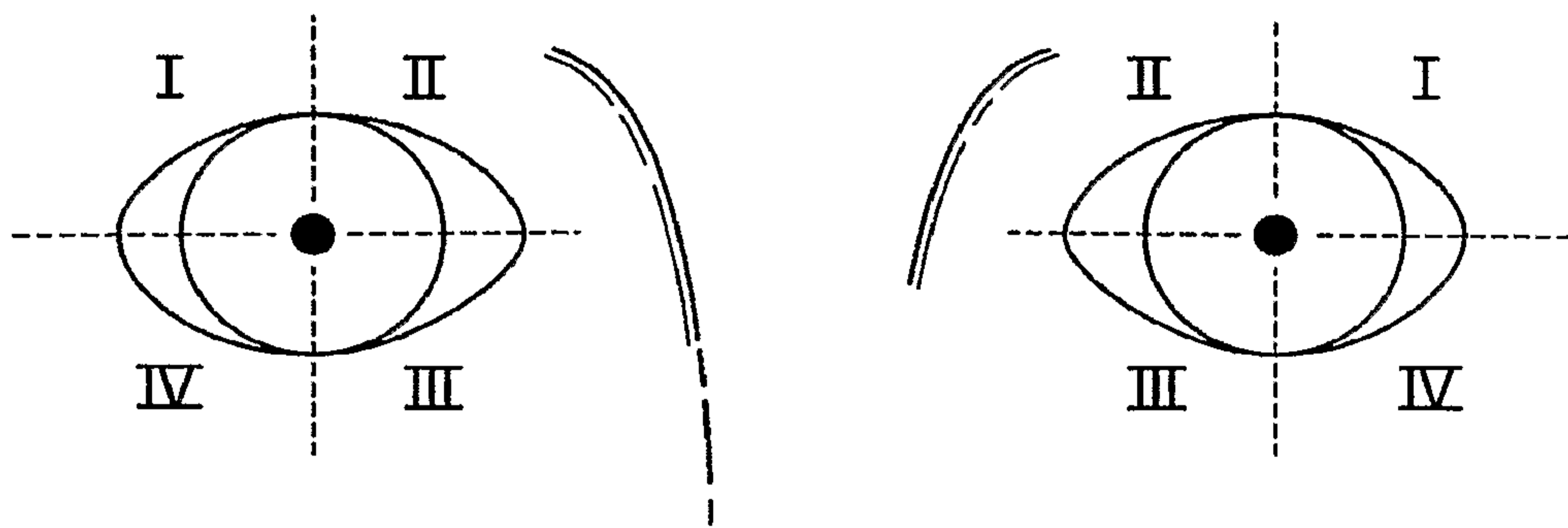

FIG. 53

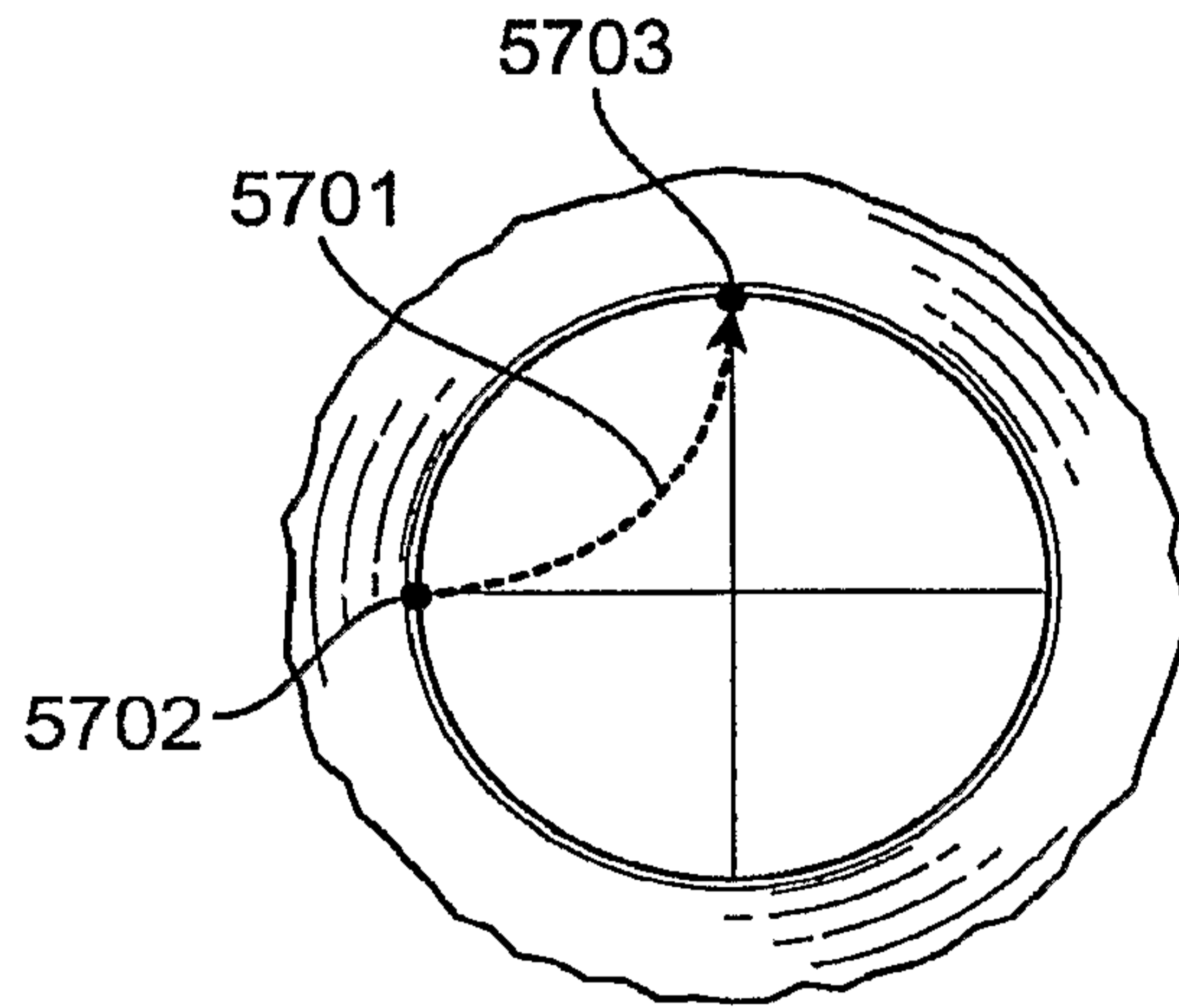

FIG. 54A

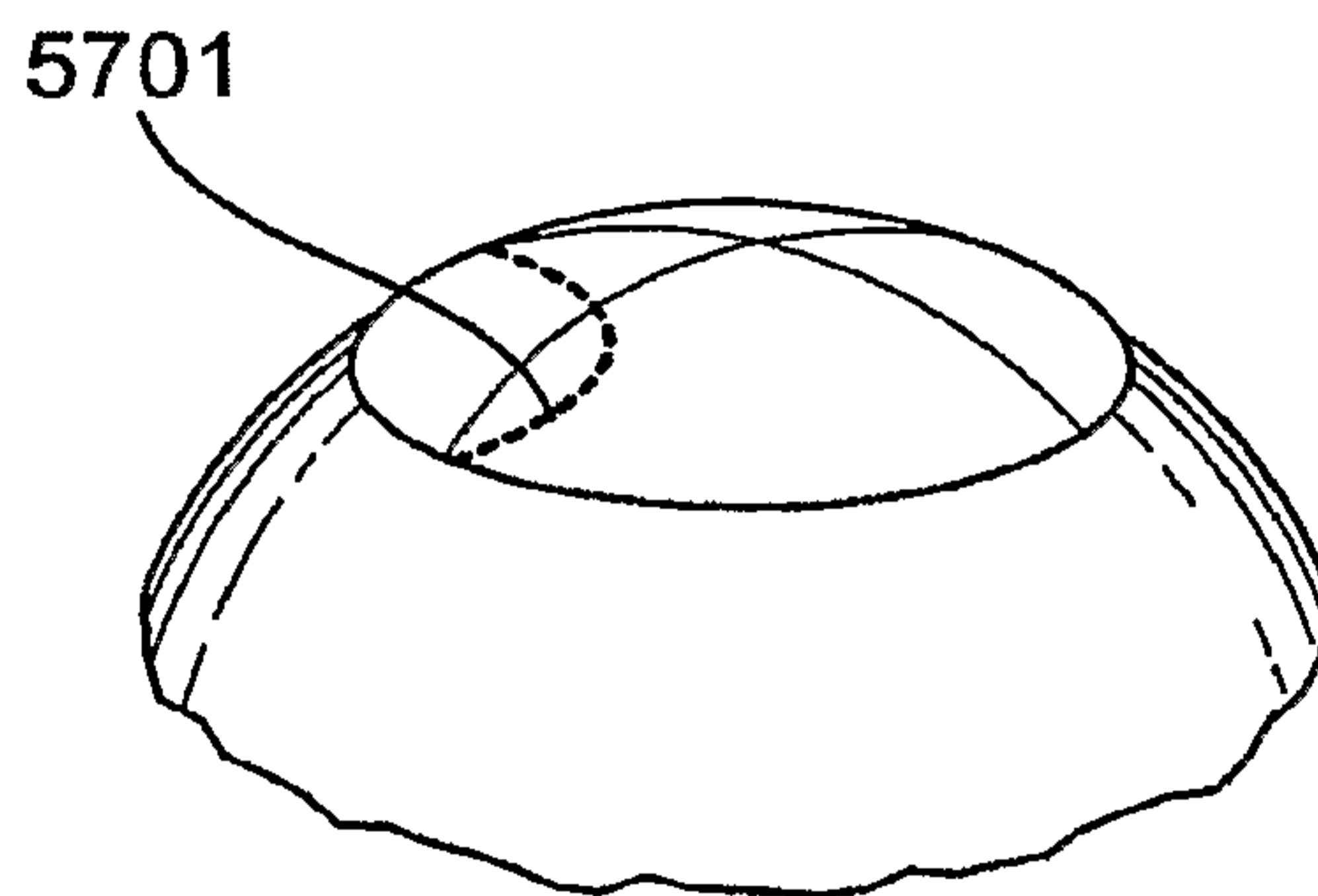

FIG. 54B

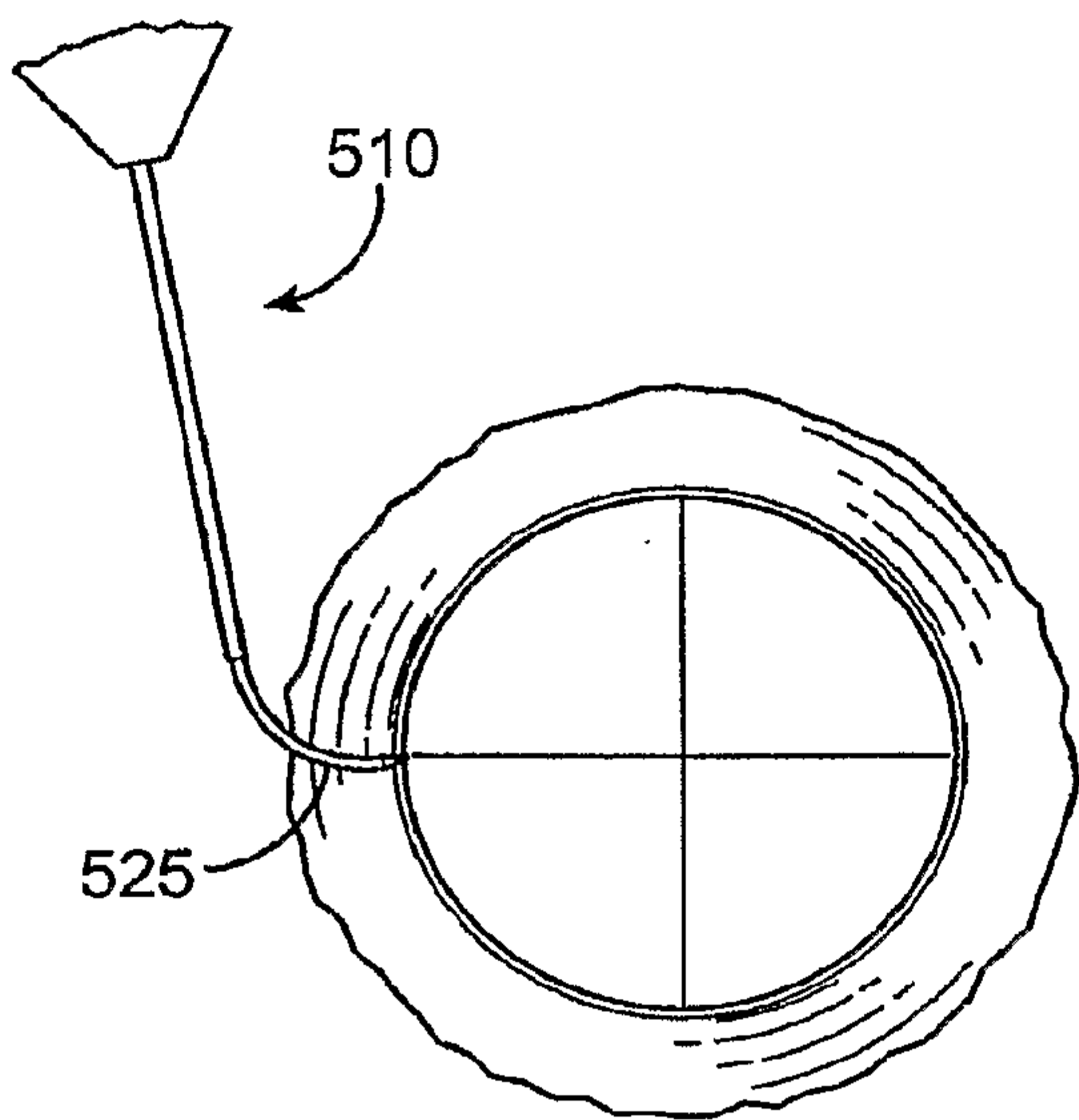

FIG. 55A

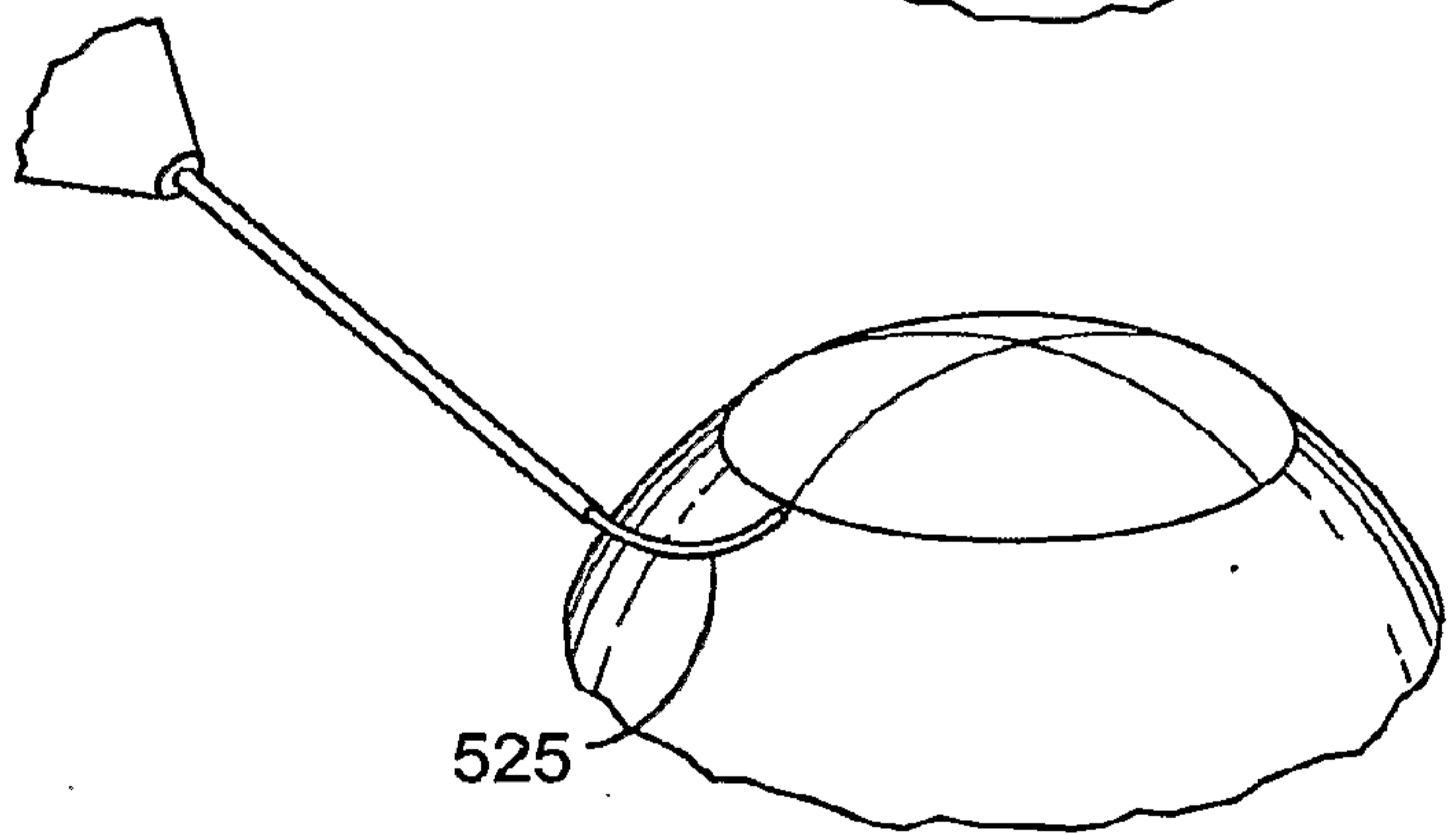

FIG. 55B

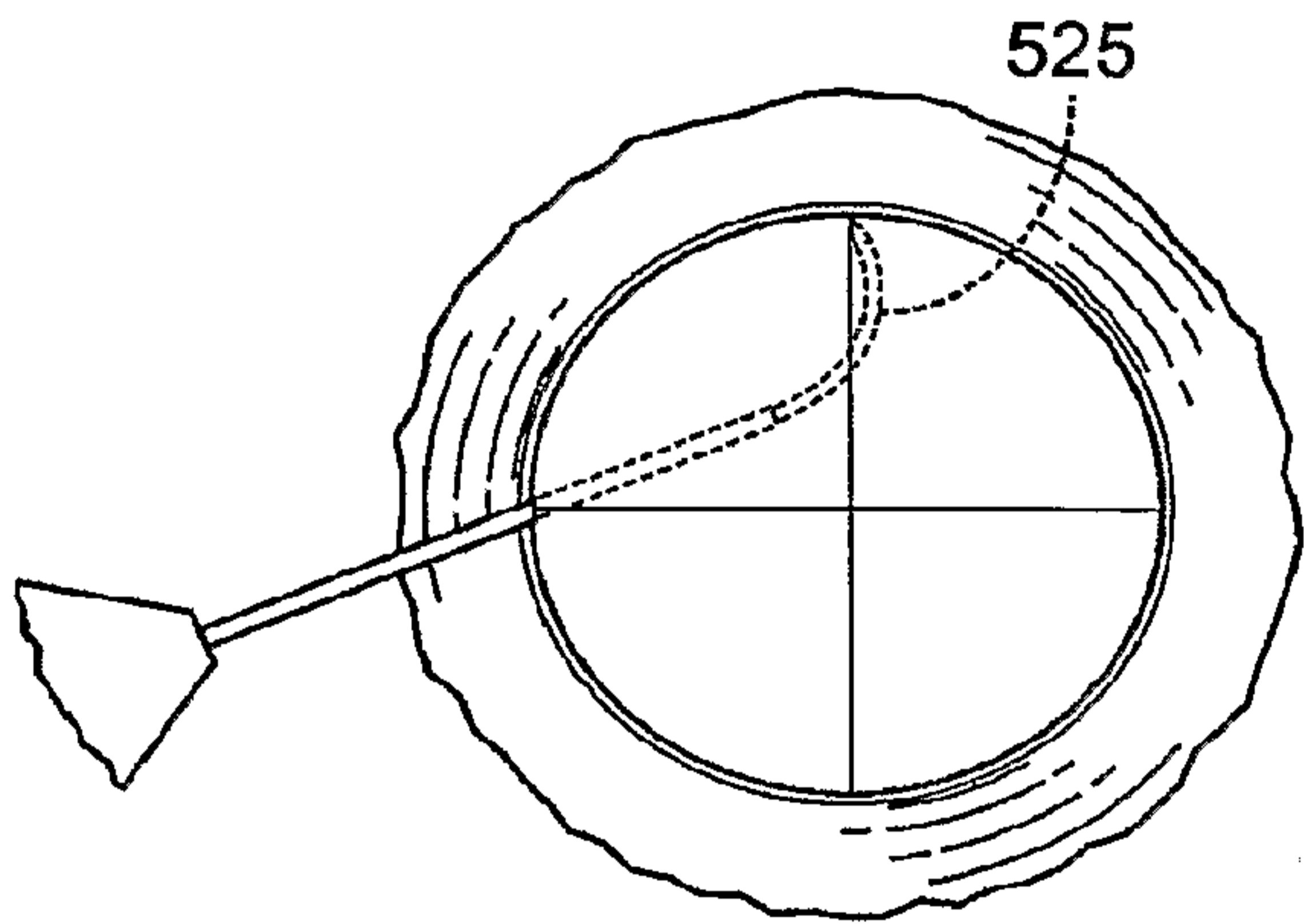

FIG. 55C

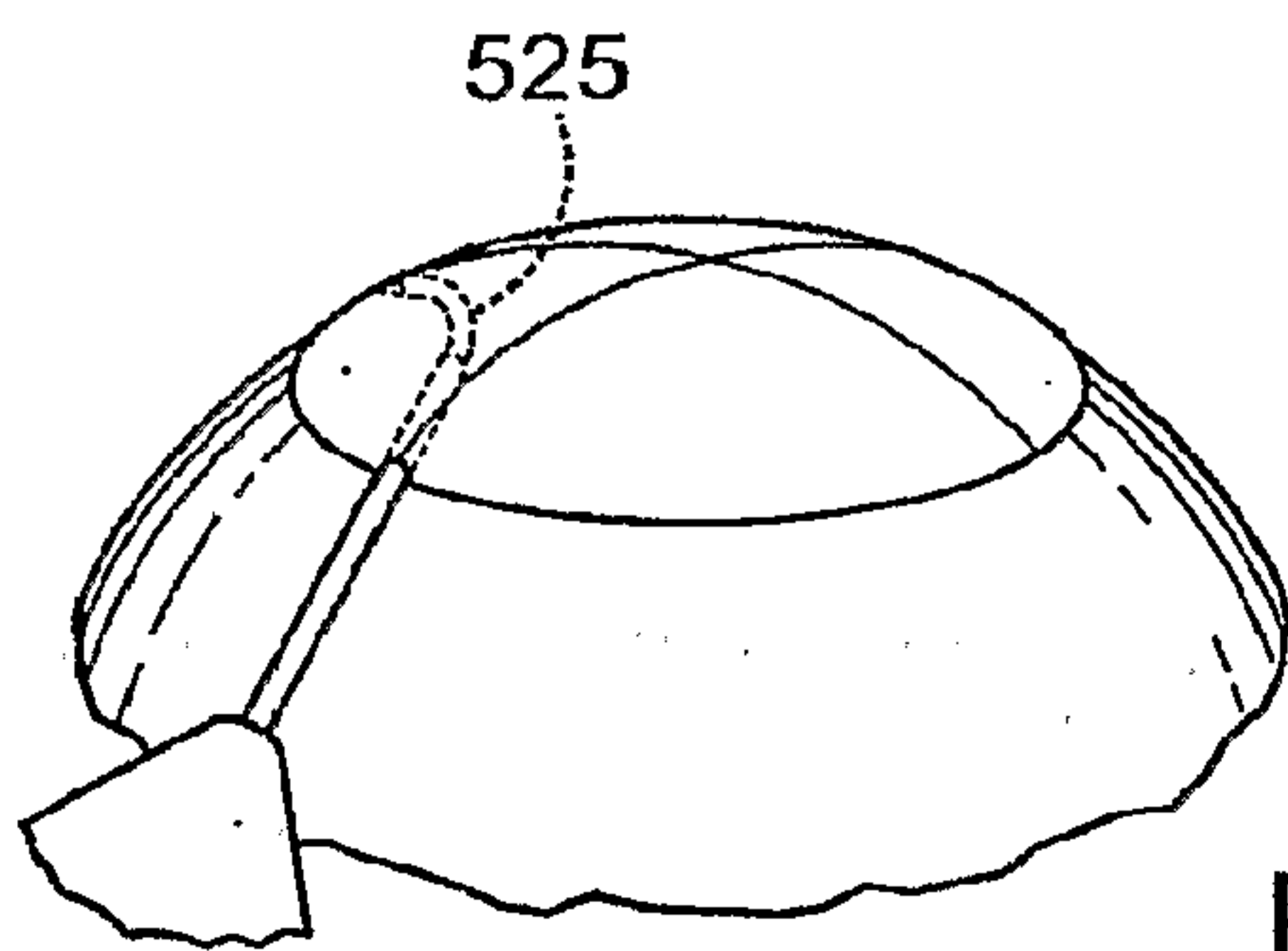

FIG. 55D

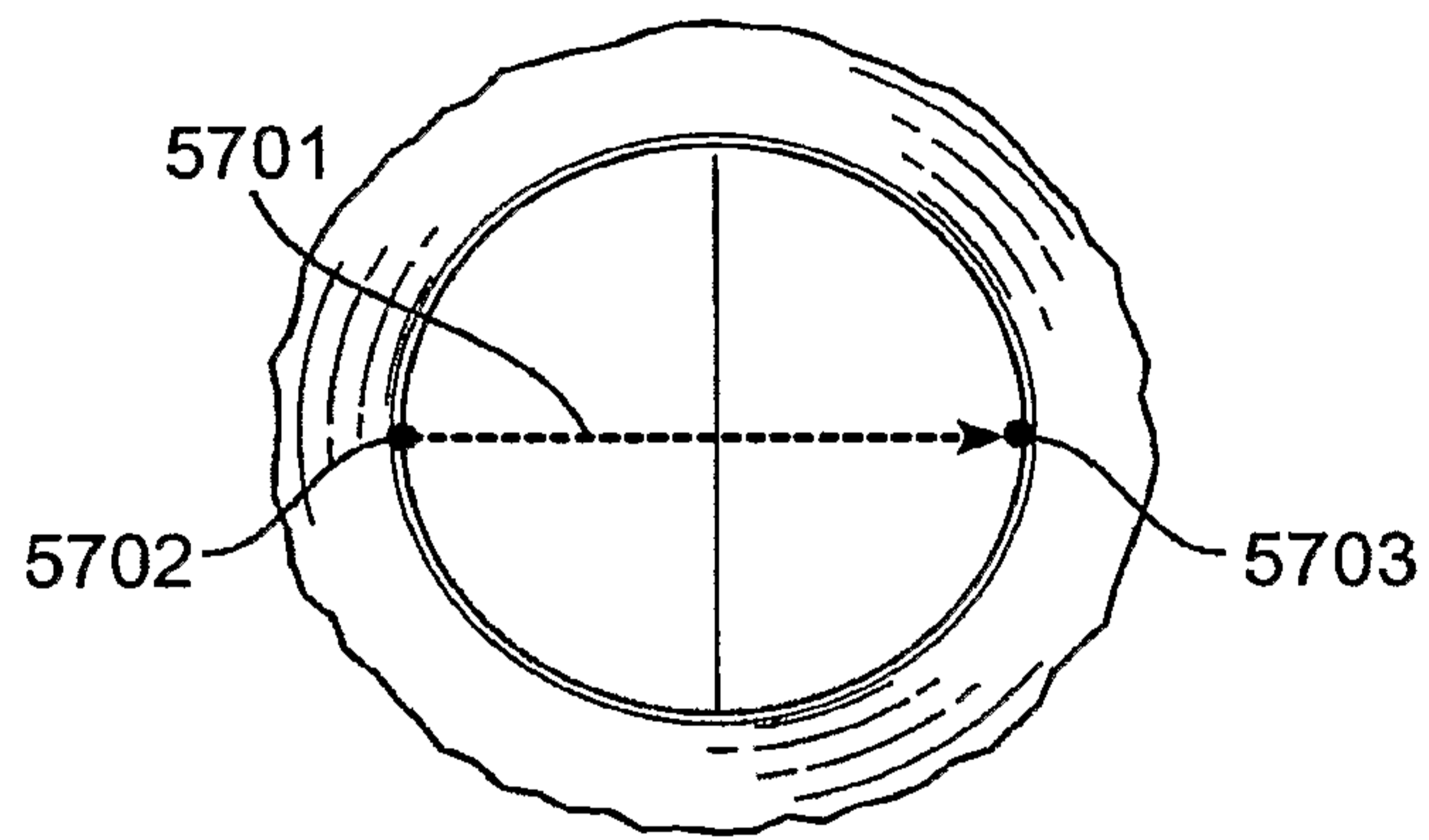

FIG. 56

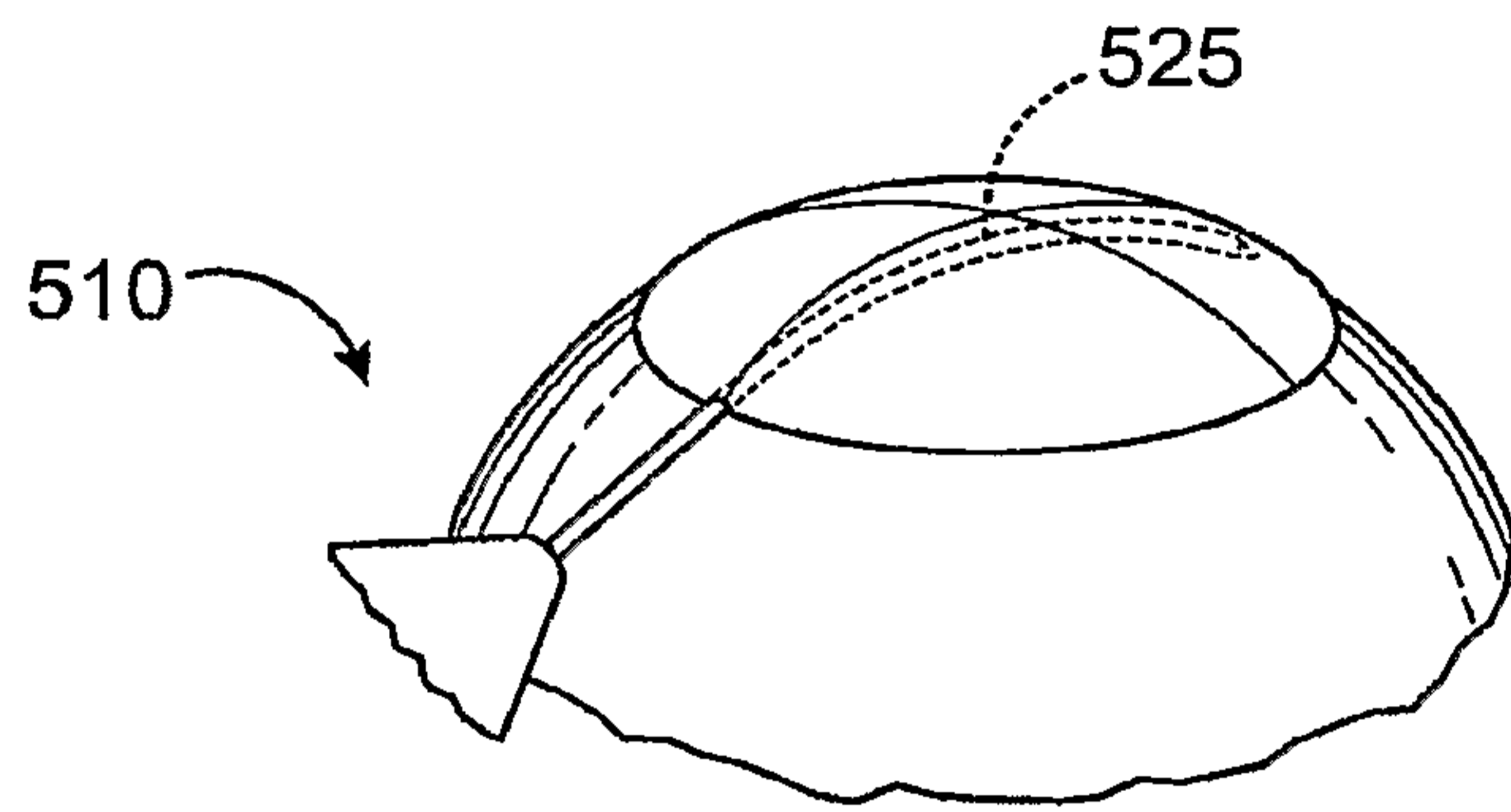

FIG. 57

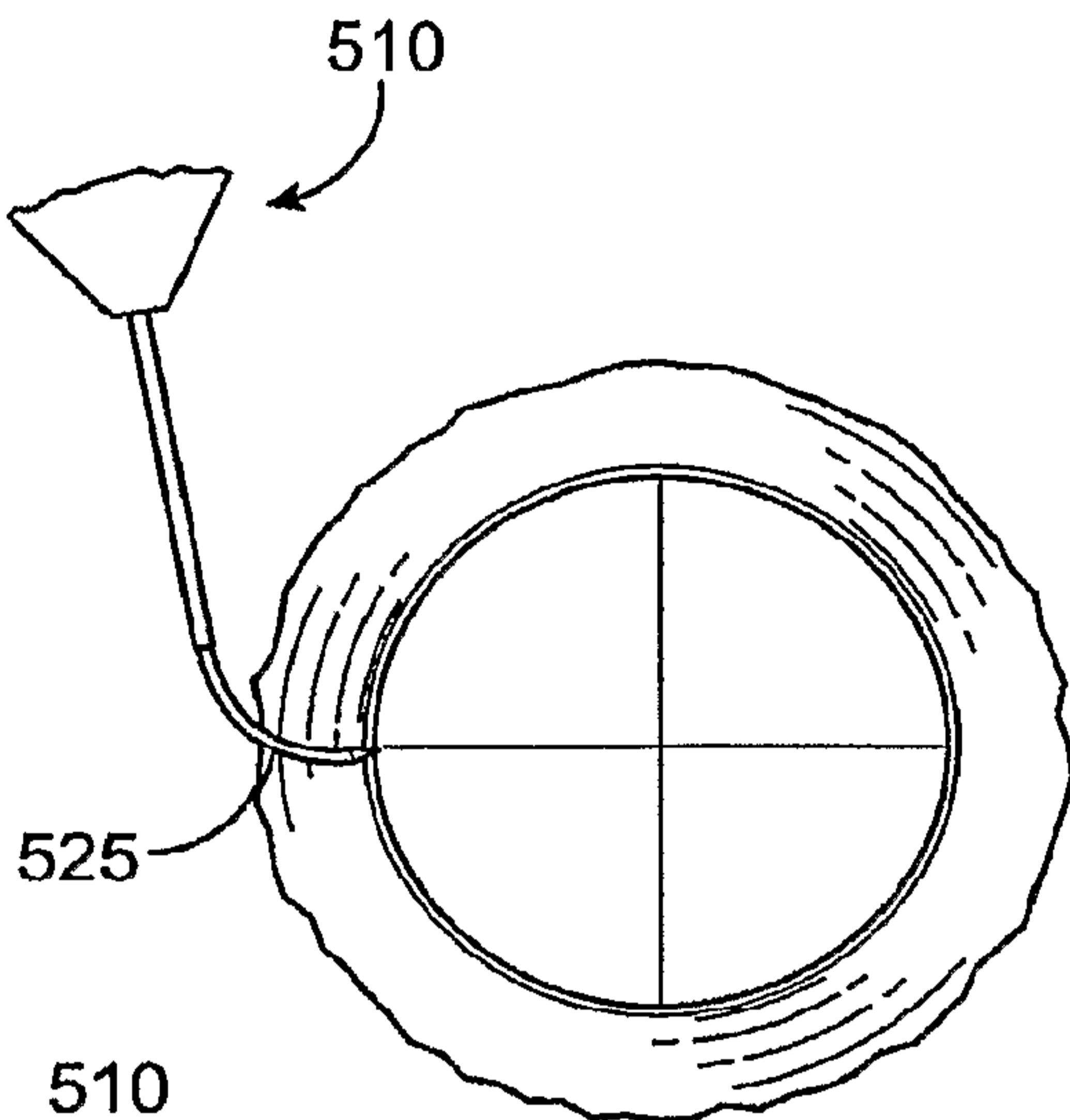

FIG. 58A

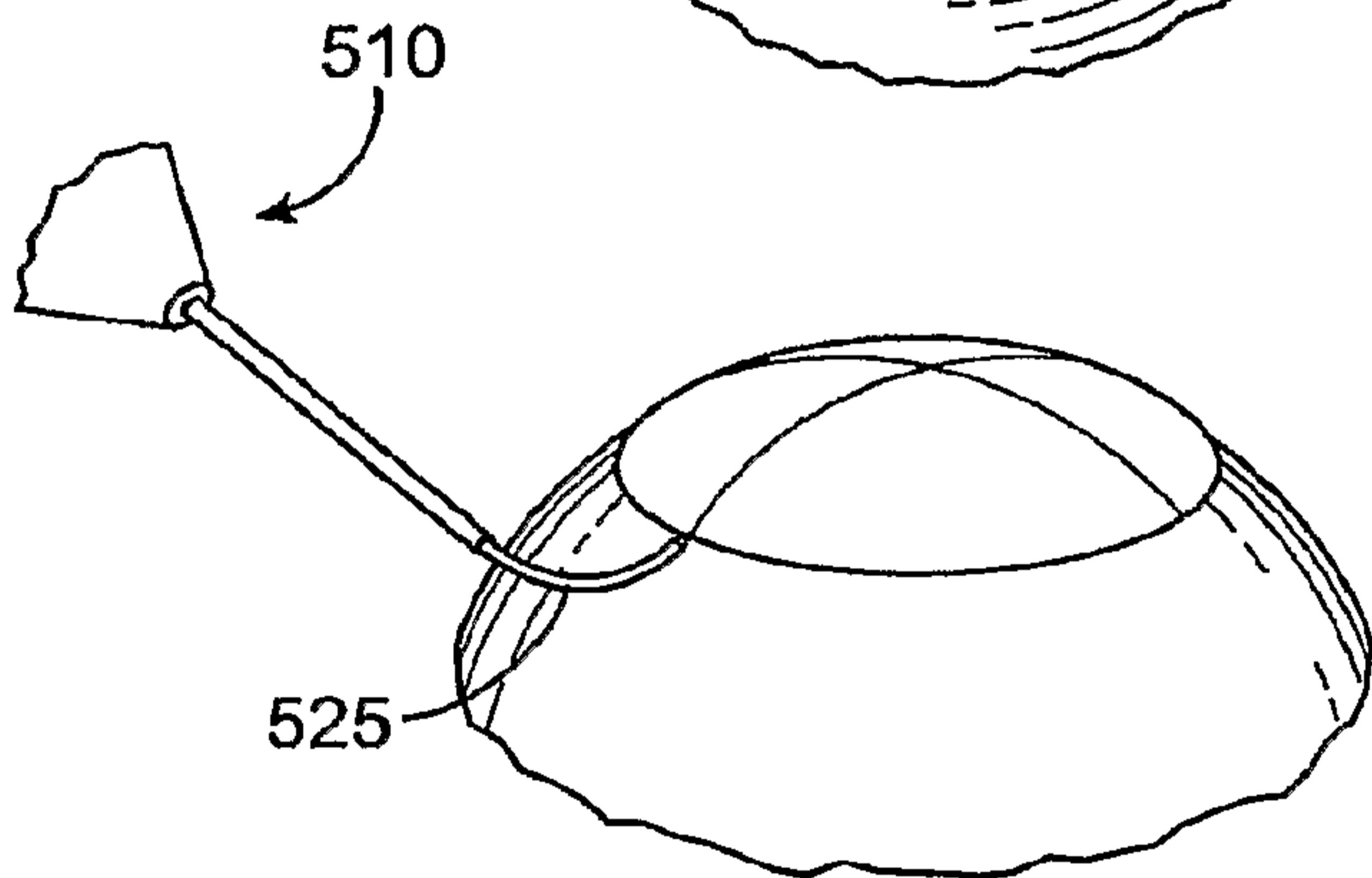

FIG. 58B

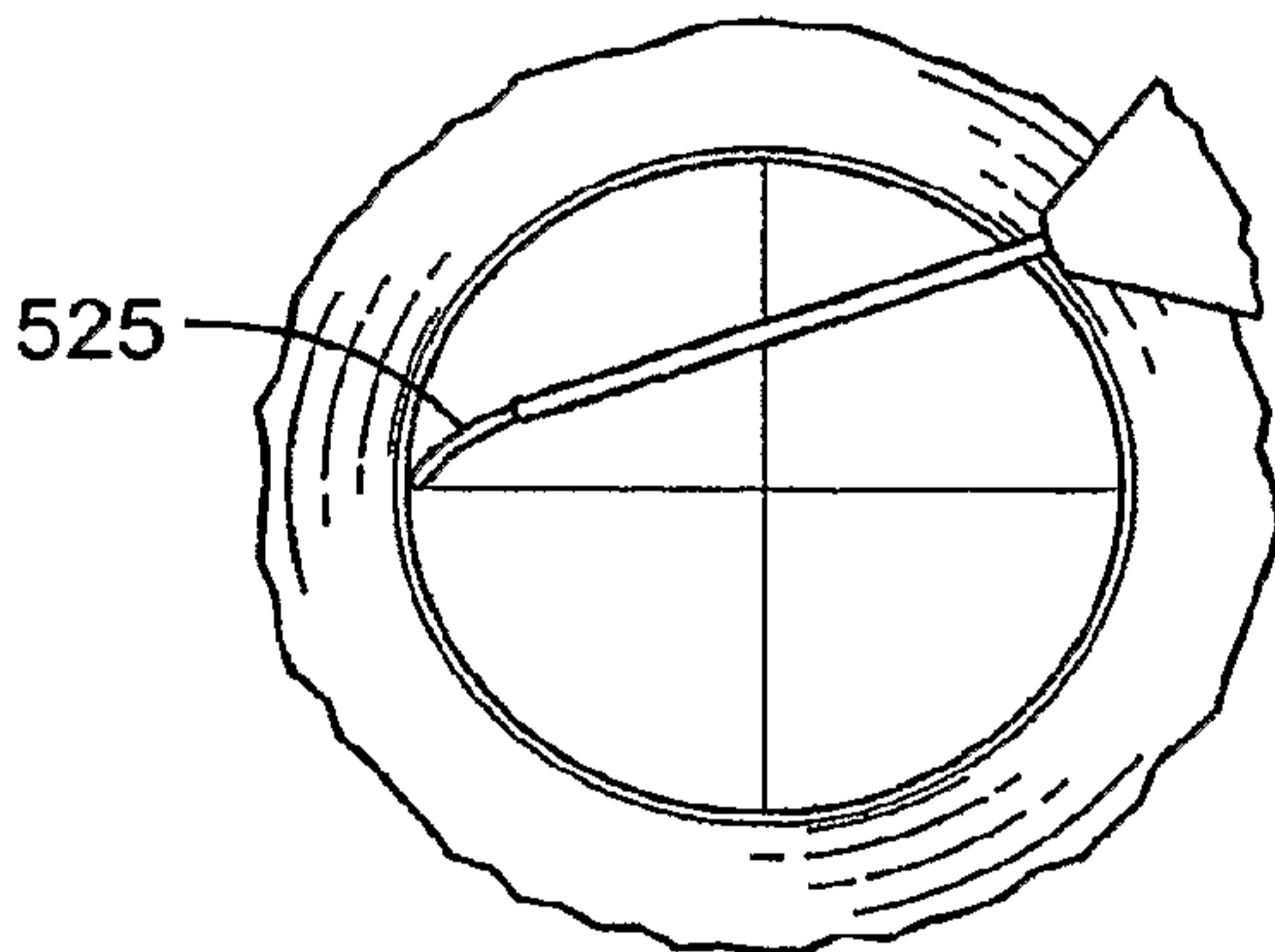

FIG. 58C

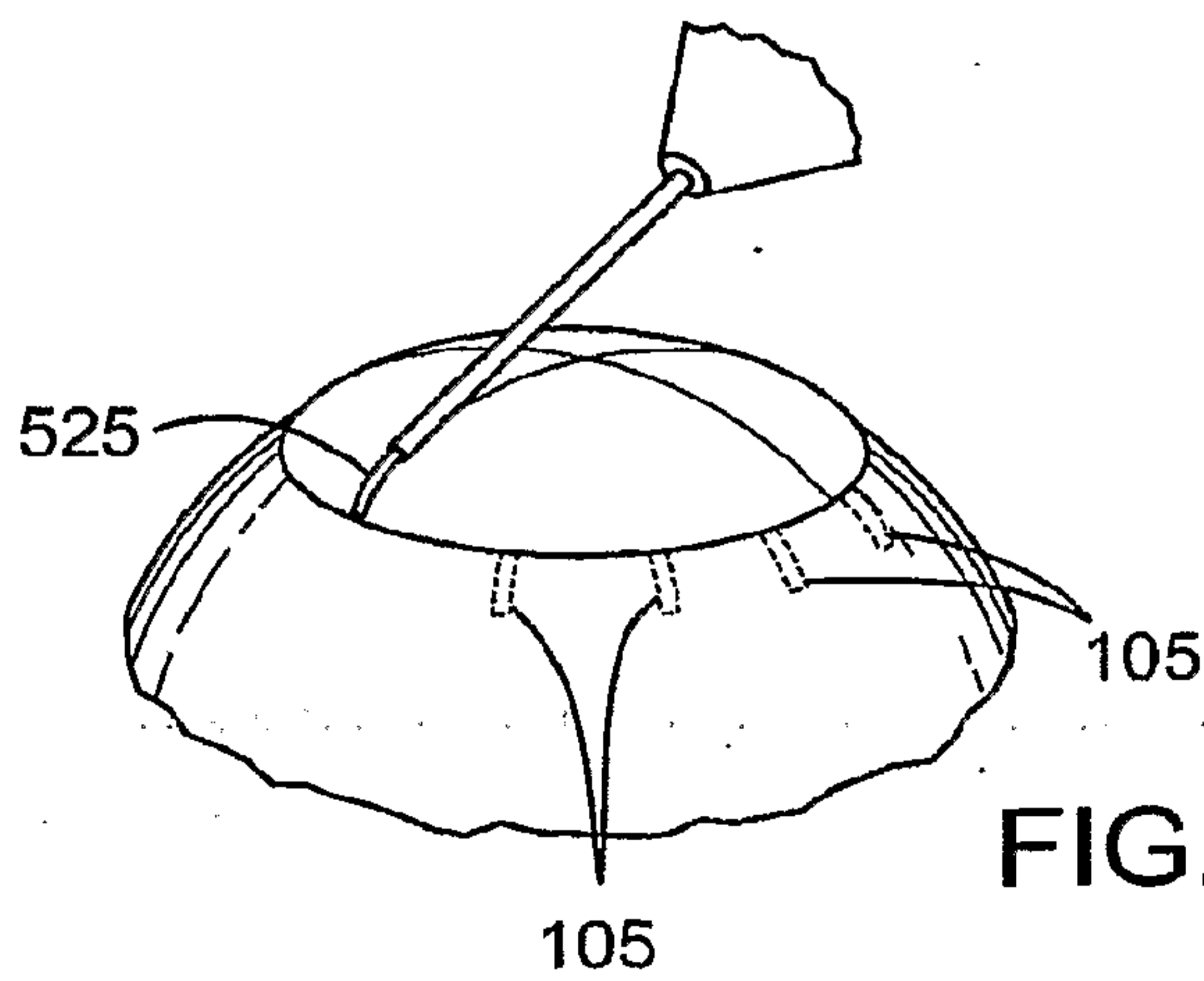
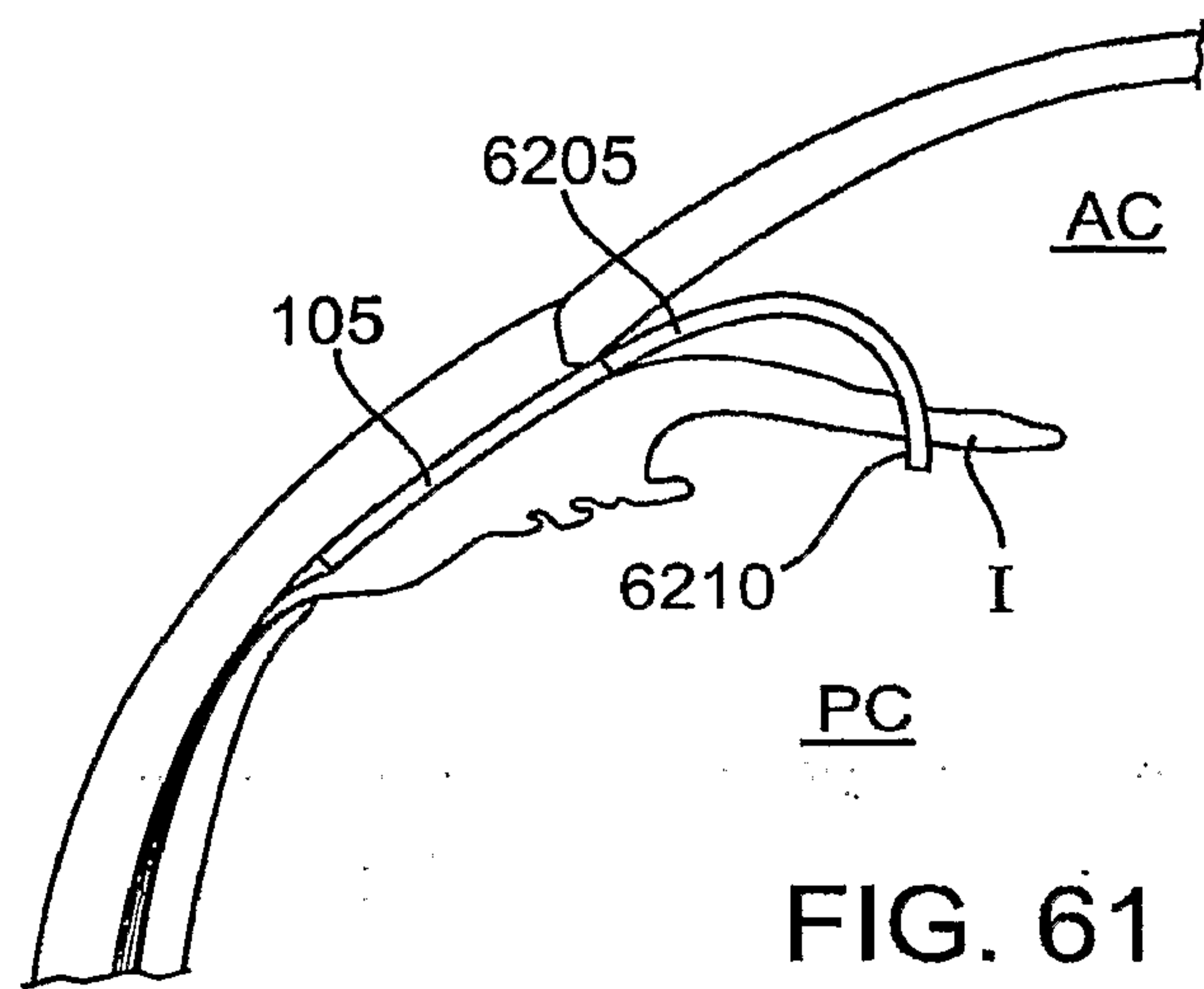
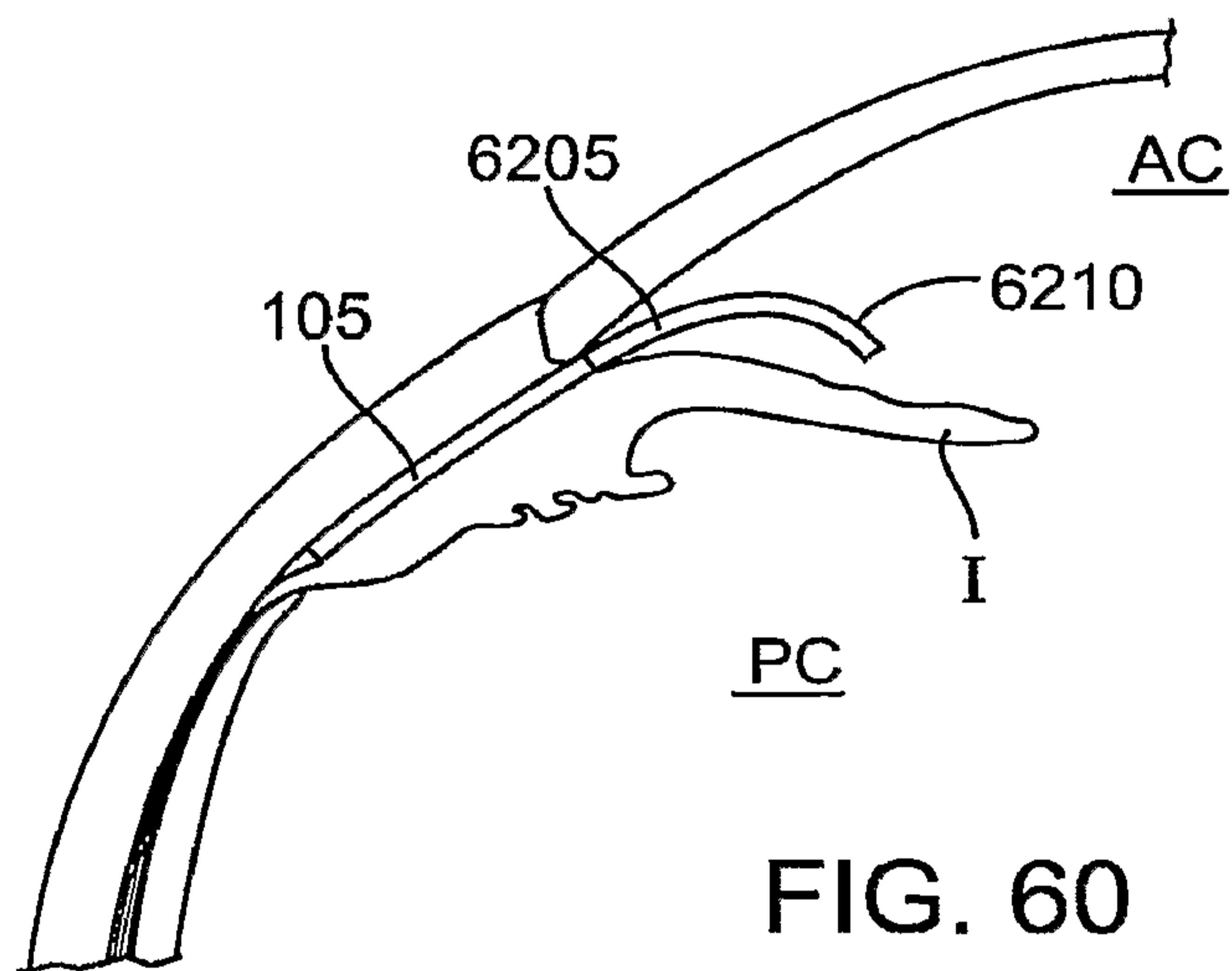
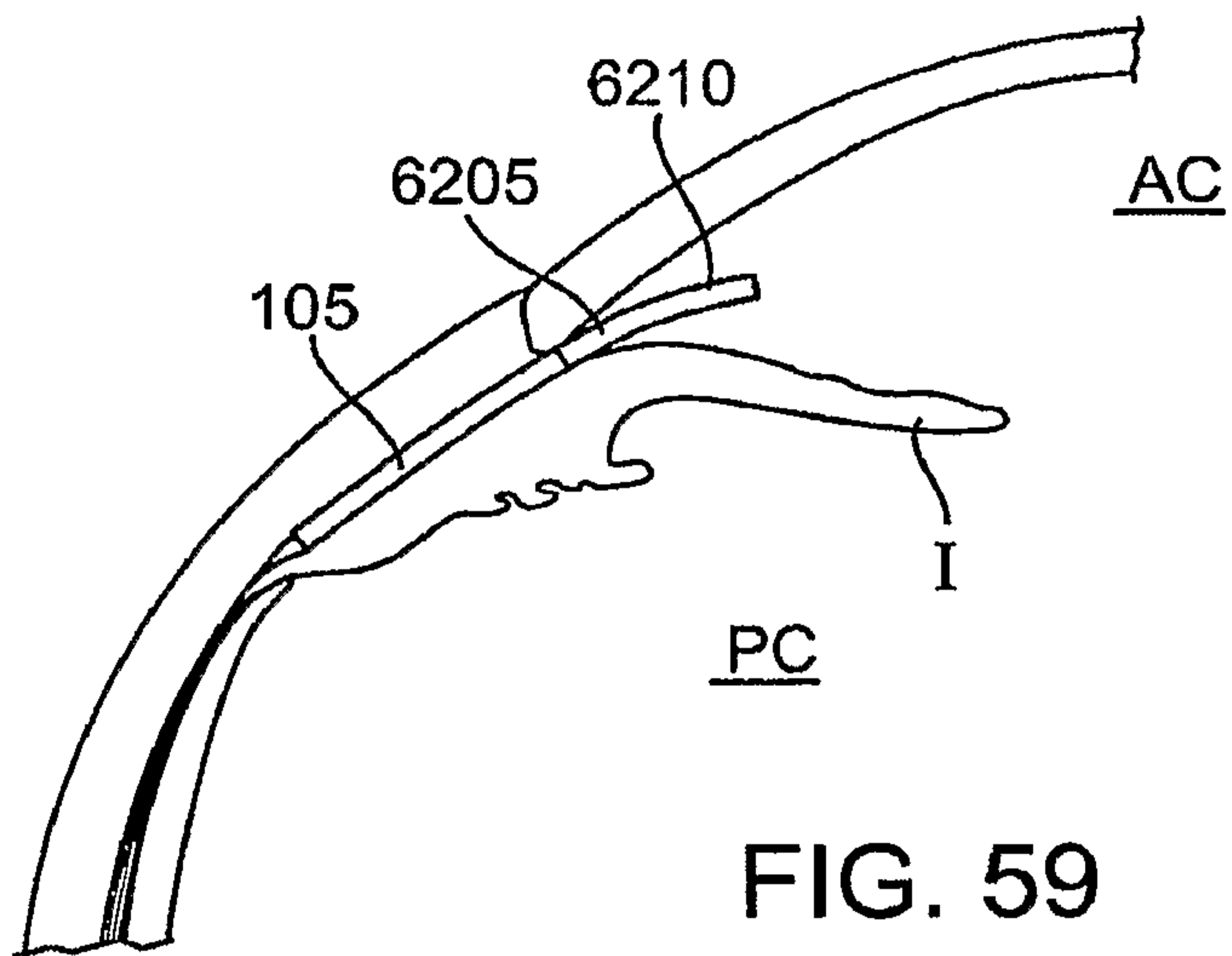

FIG. 58D



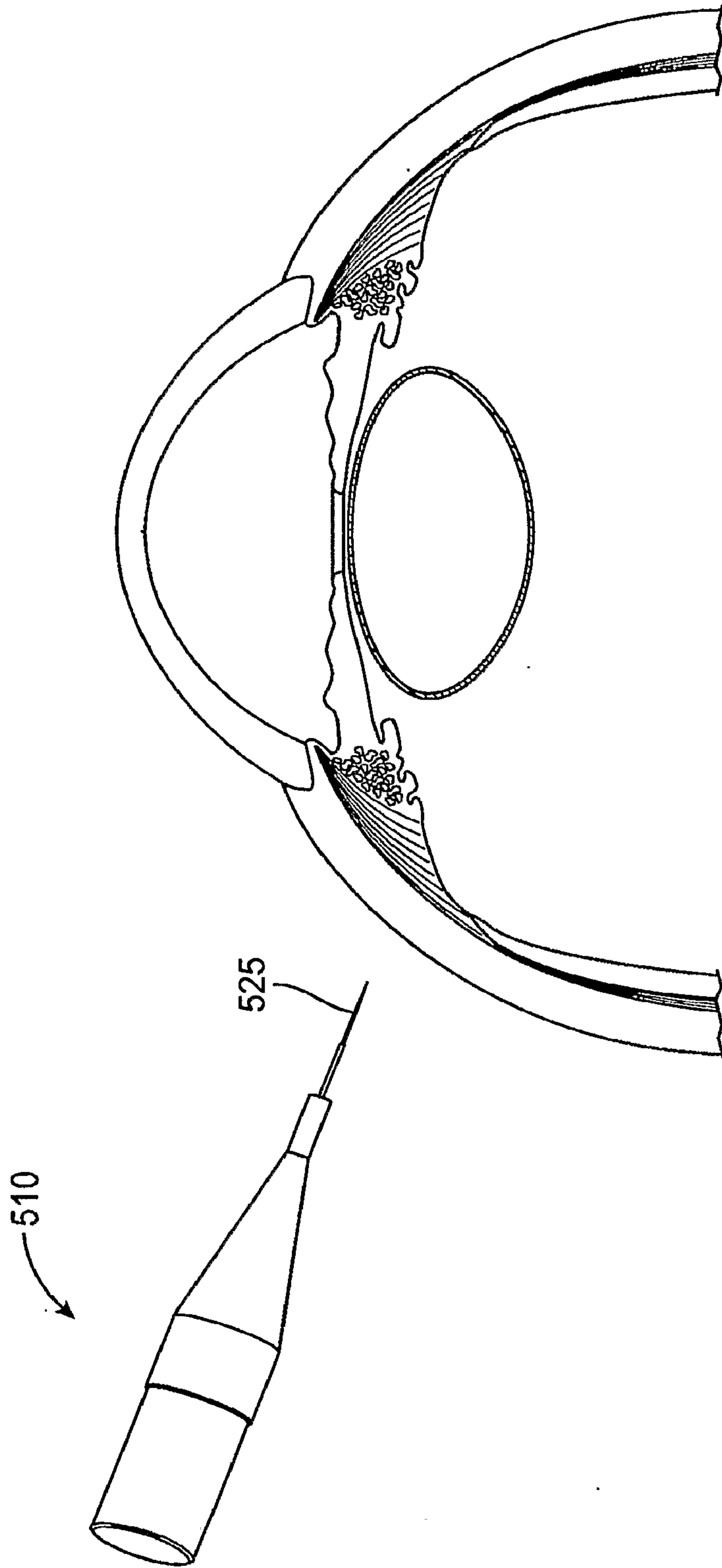

FIG. 62

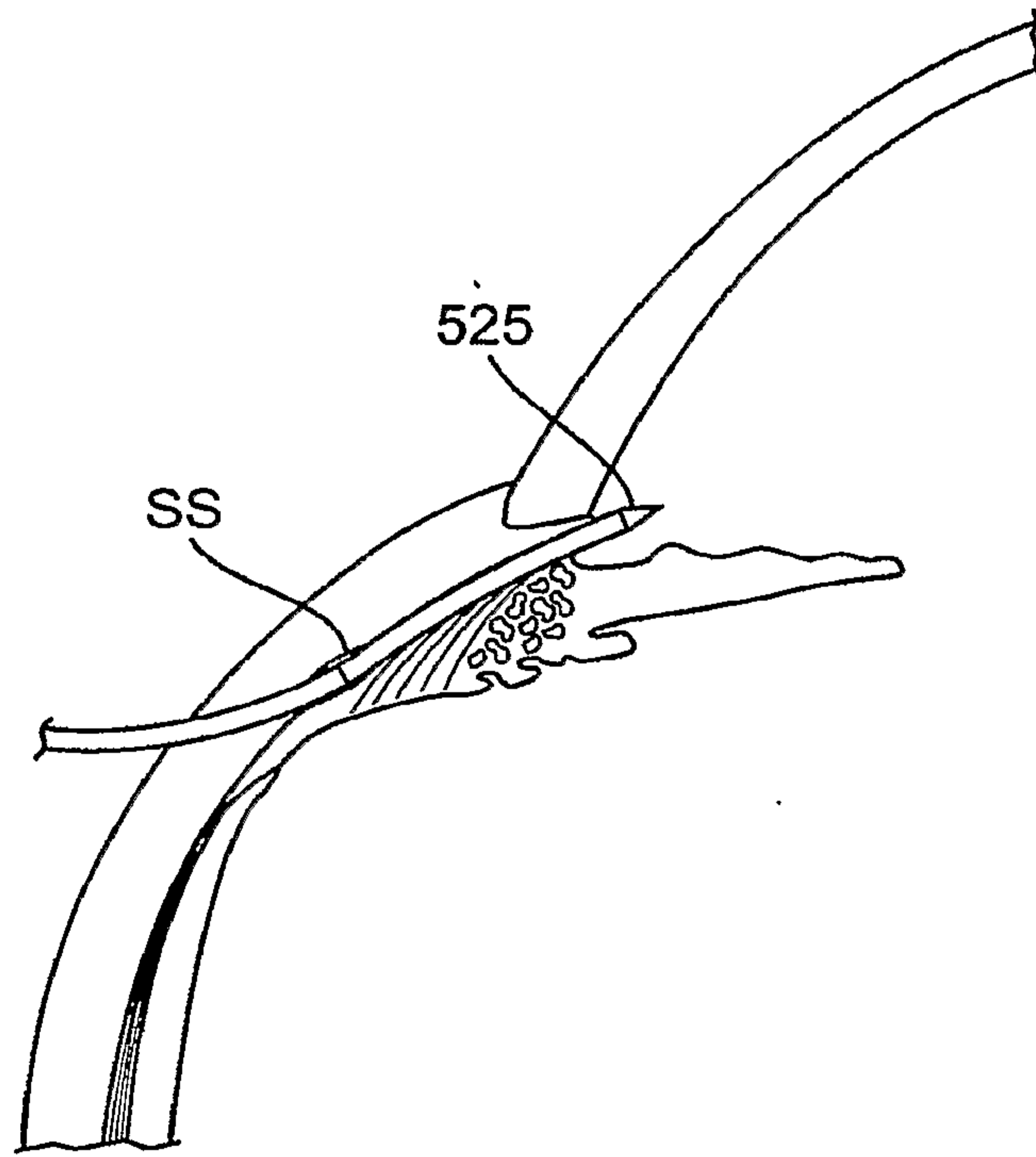

FIG. 63

115

110

105

120

