



- (51) International Patent Classification: Not classified
- (21) International Application Number: PCT/IN2016/050240
- (22) International Filing Date: 15 July 2016 (15.07.2016)
- (25) Filing Language: English
- (26) Publication Language: English
- (30) Priority Data: 922/MUM/2015 15 July 2015 (15.07.2015) IN
- (72) Inventor; and
- (71) Applicant : **BEDMUTHA, Sagar Nemichand** [IN/IN]; A-07, Saniya Heritage, Bibwewadi Kondhwa Road, Pune, Maharashtra 411037 (IN).
- (72) Inventor: **BENARE, Amol Vishnu**; B-506, Paramount Madhuban, S. No. 59, Sai Nagar, Kondhwa Bk, Pune, Maharashtra 411048 (IN).
- (74) Agent: **MAHURKAR, Anand Gopalkrishna**; KRISHNA & SAURASTRI ASSOCIATES, 74/F, Venus Worli Sea Face, Mumbai, Maharashtra 400018 (IN).

- (81) Designated States (unless otherwise indicated, for every kind of national protection available): AE, AG, AL, AM, AO, AT, AU, AZ, BA, BB, BG, BH, BN, BR, BW, BY, BZ, CA, CH, CL, CN, CO, CR, CU, CZ, DE, DK, DM, DO, DZ, EC, EE, EG, ES, FI, GB, GD, GE, GH, GM, GT, HN, HR, HU, ID, IL, IN, IR, IS, JP, KE, KG, KN, KP, KR, KZ, LA, LC, LK, LR, LS, LU, LY, MA, MD, ME, MG, MK, MN, MW, MX, MY, MZ, NA, NG, NI, NO, NZ, OM, PA, PE, PG, PH, PL, PT, QA, RO, RS, RU, RW, SA, SC, SD, SE, SG, SK, SL, SM, ST, SV, SY, TH, TJ, TM, TN, TR, TT, TZ, UA, UG, US, UZ, VC, VN, ZA, ZM, ZW.
- (84) Designated States (unless otherwise indicated, for every kind of regional protection available): ARIPO (BW, GH, GM, KE, LR, LS, MW, MZ, NA, RW, SD, SL, ST, SZ, TZ, UG, ZM, ZW), Eurasian (AM, AZ, BY, KG, KZ, RU, TJ, TM), European (AL, AT, BE, BG, CH, CY, CZ, DE, DK, EE, ES, FI, FR, GB, GR, HR, HU, IE, IS, IT, LT, LU, LV, MC, MK, MT, NL, NO, PL, PT, RO, RS, SE, SI, SK, SM, TR), OAPI (BF, BJ, CF, CG, CI, CM, GA, GN, GQ, GW, KM, ML, MR, NE, SN, TD, TG).

Published:

— without international search report and to be republished upon receipt of that report (Rule 48.2(g))

(54) Title: METHODS AND DEVICES TO DISPLAY BALANCE STATUS AND MAKE PAYMENT VIA MOBILE DEVICES

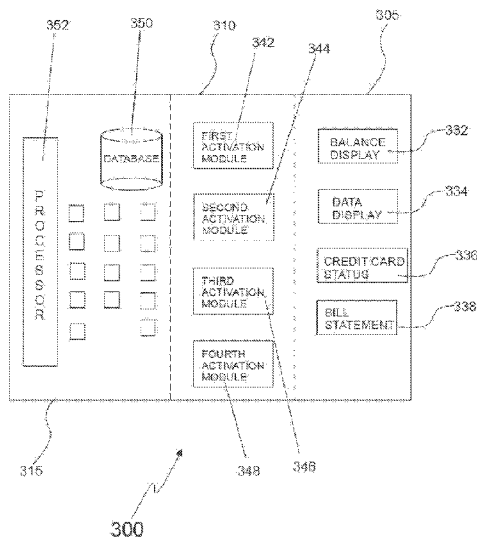
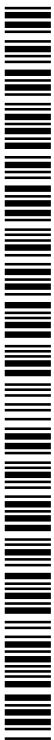

FIG. 3A

(57) Abstract: Disclosed is a system for displaying balance status and making payment via a communication device which includes a microcontroller having a processor, a system memory and a plurality of modules. The system of the present invention is configured to automatically display a latest updated value of a plurality of predefined credentials in form of a bubble on a display screen of the communication device. In addition, the system of the present invention provides alert messages on the communication device at right time, right place and in simple and actionable manner.



METHODS AND DEVICES TO DISPLAY BALANCE STATUS AND MAKE PAYMENT VIA MOBILE DEVICES

Field of the invention

The present invention relates to mobile telecommunication systems and more particularly to a system for displaying balance status, payment alerts and making payments via a cellular communication device.

Background of the invention

Systems that provide updates about status of certain parameters are beneficial to users. In case of telecommunications, when a subscriber uses a service, the subscriber's account is debited based on the subscriber's usage and a particular service plan or other pricing system. One tool for managing a subscriber's account is monitoring the account balance over time. In prepaid mobiles services, the credit balance keeps on decreasing with every call, SMS, internet service usage or other mobile services usage. Further, the rate of decrease varies based on call duration, service plan, time of usage, roaming and many other factors. Moreover, usage of multiple service providers from a same mobile device makes remembering balance information complicated and confusing. Therefore, the pre-paid account subscriber wants to have real-time information of the account balance. In case of postpaid mobile services, bills are presented for payment after the service has been consumed. Even subscribers of post-paid accounts want an accurate idea of the charges they have accrued in their account.

Generally, the user gets balance status or due amount information automatically either via a call, SMS, email or other short message. The user can also manually get the information by dialing to some predefined number or sending a text query. However, remembering such dynamically changing balance information and due dates is very tedious. Moreover, many of the online services and credit cards provide some sort of offers or loyalty points or discounts. So while making payment for the services, the

user may not be well aware about the best offers available at that particular time and hence may fail to utilize the same.

Efforts are being made to provide information of balance in a real-time to the users.

系 For example, patent number US8170527 B2 to Visa U.S.A. Inc. discloses a system, method and a prepaid payment mobile phone configured to display a current prepaid balance. The prepaid payment mobile phone receives a debit balance request from an input on the mobile phone. After retrieving an encoded current balance, the mobile phone displays the amount. The current balance may be calculated by the phone after 系 a transaction or the phone may receive a debit balance via a short message service notification.

Another patent number US8478231 B2 to Motorola Mobility LLC discloses a method of a mobile communication device, a device and a method of a server for updating the 系 prepaid balance during the active mode of the mobile communication device. The method of the device includes storing in memory a stored prepaid balance prior to initiating a wireless communication via a service provider, initiating an active mode wireless communication and transmitting, during the active mode wireless communication, at least one balance query to the service provider.

系 Another patent US8532623 B2 to Motorola Mobility LLC discloses methods of a mobile communication device for processing a balance information message from a service provider in response to a balance information query. The method includes obtaining a service provider identity from a SIM, determining a format of a balance 系 information message and identifying a balance information message from the service provider according to the format of the balance information message.

However, the prior art systems and methods fail to track usage details of the post-paid accounts. In addition, the prior art systems and methods need manual intervention for

checking the balance status and provide balance details in different sets of information which is difficult for understanding. Further, the prior art documents do not provide to the user information about the pre-paid balance in real-time before making the call and every time user needs to check the balance by dialing a predefined number or by sending SMS to the service provider. Furthermore, the systems of the prior art do not provide alert to the user in case the prepaid balance is below a predefined amount or the data usage exceeds the service plan. The systems of the prior art do not provide a prompt payment options such as online payment to the user if the balance is below the predefined amount. Moreover, the prior art fails to disclose a system that provides real-time information of pre-paid as well as post-paid accounts, data usage and availability of text messages.

Hence, it would be very beneficial if the user could get the balance information, validity and due dates with minimum efforts or in an automated way and in an easy to understand manner. Further, it would be convenient if such information is presented to the user at the right time and right place like a prompt showing available credit balance information before making a phone call, a prompt showing SMS pack balance and validity on SMS composing screen and a prompt showing due bill for credit card when the user's mobile is connected to internet.

It would be even more useful if the user gets the payment prompts and options that are dynamically based on his/her service usage, location, profile, credit score, current financial balance and payment history. Since typing on mobile devices is difficult, it would be very convenient for the user if all or part of the payment process is automated like automatic filling up the forms with information like name, account number, address, storing and remembering the past transactions for repeat use.

Sometimes, to make payment, the user may not have access to a retailer or may not have enough funds or may not have internet connectivity. In such situations, it would

be very beneficial for the user if the balance status or payment prompts also give options to share that information and provide the user options to directly call, message or send predefined message to persons that may have close relationship with the user.

系

Accordingly, there is need of a system for displaying balance status and making payment via a communication device that overcomes all the drawbacks of the prior art.

系 Summary of the Invention

The present invention provides a system for displaying balance status and making payment via a communication device that comprises a microcontroller having a processor, a system database and a plurality of modules configured thereon. The system of the present invention includes a monitor module that is configured to monitor a plurality of background actions being performed by the communication device. The monitor module is configured to constantly monitor information received from a controller, a database and an operating system of the communication device. The monitor module is configured to analyse and compare said information with predefined trigger information from the system database for displaying a latest updated value of a plurality of predefined credentials. The plurality of predefined credentials include a talk time balance, a data balance, a credit card balance, a bill amount, an account balance and the like.

換 The system of the present invention includes a display module that is configured to communicate with the processor, the system database and the monitor module for deriving a predefined data from the system database. The display module is configured to actuate a bubble display mechanism. The bubble display mechanism forms a secondary screen on a predefined display layer of the communication device.

系 The secondary screen has a bubble configured thereon. The bubble is configured to be located at a predefined location on the predefined display layer. The bubble is configured to display a latest value of the predefined credentials on the predefined display layer. The bubble is manually movable within a predefined boundary defined by the predefined display layer.

系 The system of the present invention includes a language module that is configured to communicate with the processor. The language module selects and communicates in a preconfigured language of the communication device. The system of the present invention includes an alert module that is configured to communicate with the processor and the monitor module. The alert module generates an alert message if actual value of the predefined credentials falls below a minimum set value.

系 The system of the present invention includes a screen information capture module that is configured to capture information available on display screen of the communication device to further communicate with the system database for authenticating the predefined credentials. The system of the present invention includes a logic unit that is configured to analyse information captured by the screen information capture module using a preconfigured data in the system database. The system of the present invention includes a user profile module that is configured to analyse and store information of the user based on a plurality of user credentials. The plurality of user credentials include information such as a gender of user, an age of user, a location of user, a usage pattern, a recharge pattern, and a calling pattern.

系 The system of the present invention includes a network detection module that is configured to communicate with a service provider for detection of network information of the communication device. The system of the present invention includes a mobile device specification module that is configured to communicate with the processor to investigate specification and compatibility of the communication

device. The system of the present invention includes a dial mechanism that is configured to dial a predefined or user given code or number to check a network type, a service provider type and a data type to be derived from the network Service Provider.

系

The system of the present invention includes a SIM detection module that is configured to check and derive SIM status information about SIM in the communication device. The system of the present invention includes a billing unit that is configured to track usage of billable services provided by the service provider.

系 The system of the present invention includes a service type detection module that is configured to communicate with the service provider to decide a type of service being provided by the service provider. The system of the present invention includes a payment module that is configured with an online payment mechanism to show a plurality of payment option to the user. system of the present invention includes a 系 cross check module that is configured to communicate with the plurality of modules to predict information such as talk time balance usage, data balance usage, remaining talk time balance, remaining data balance, pending amounts and validity dates.

In one embodiment, the present invention provides a method for displaying balance 系 status and making payment via a communication device that comprises an initial step of identifying specifications of the communication device by a mobile device specification module for checking compatibility thereof. In next step, type of hardware of the communication device is checked by communicating with a system database. In next step, SIM slot check is performed for identifying quantity of SIM 系 slots in the communication device. In next step, actual SIM check is performed by extracting and comparing SIM information of the communication device with preconfigured information in the system database. In next step, a network detection module is activated thereby communicating with the service provider to detect network information. In next step, a language module is activated to read a

preconfigured language of the communication device. In next step, an access to a plurality of actions pertaining to the user and data is authenticated. In next step, a service subscription type is decided based on the user input. In next step, a monitor module is activated for constantly monitoring a plurality of background actions being performed by the communication device. In next step, a dial mechanism is activated on a predefined dialer to obtain balance status of the SIM in the SIM slot. In further step, balance status information is authenticated, captured and stored in the system database by an information capture module. In next step, a logic unit is activated for analyzing captured information and recording a first balance of a plurality of predefined credentials followed by storing said first balance in the system database. In further step, a user profile is created by a user profile module followed by storing the user profile information in the system database. In next step, dialer information in form of a predefined display layer is captured followed by storing said dialer information in the system database. In next step, the predefined display layer is activated through the processor. In further step, a bubble is created at a predefined position on the predefined display layer of the dialer thereby displaying a latest value of the plurality of predefined credentials. In next step, the latest value of the predefined credentials is updated by the monitoring module followed by displaying the latest value of the predefined credentials on the bubble. In next step, an alert message is created through an alert module if actual value of the predefined credentials falls below a minimum set value. In final step, a plurality of payment options is provided on the communication device based on the alert message.

In an alternative embodiment, the present invention provides a peer-to-peer communication method for balance communication between a plurality of communication devices that comprises an initial step of installing a microcontroller on at least one primary device and at least one secondary device. The microcontroller in this one alternative embodiment includes a processor, a system database and a plurality of modules configured thereon. The plurality of modules in this one

alternative embodiment include a logic unit, a network detection module, a screen information capture module, a language module, a mobile device specification module, a dial mechanism, a display module, a SIM detection module, a monitor module, an alert module, a user profile module, a billing unit, a service type detection module, a payment module and a cross check module. In next step, a communication between the primary and secondary devices is facilitated through a system server. In next step, the secondary device is configured to share a plurality of authentication credentials to the primary device thereby communicating with the system server. In next step, the primary device is configured to authenticate the plurality of authentication credentials thereby communicating with the system server. In next step, the primary and secondary devices are allowed to form a group through the system server. In further step, the predefined credentials of the primary and secondary devices are monitored thereby generating an alert message if actual value of the predefined credentials of the secondary device falls below a minimum set value. In next step, the alert message is conveyed to the primary device through the system server. In final step, the primary device is facilitated to take a plurality of necessary actions with regard to the secondary device through the system server. In this one alternative embodiment, the plurality of necessary actions includes a balance recharge, a data recharge, a credit card payment, a third party payment and the like.

机

Brief description of drawings

FIG. 1 is an environmental representation of a system for displaying balance status and making payment via communication device in accordance with the present invention;

换

FIG. 2 shows system details of a communication device adapted for the system for displaying balance status and making payment;

FIG. 3A is a system architecture of the system for displaying balance status and making payment via the communication device in accordance with the present invention;

系 FIG. 3B is a system architecture of a back layer of the system of FIG. 3A;

FIGS. 4A- 4B show a flowchart for activation of the system of FIG. 3A;

FIG. 5 shows a bubble screen mechanism of the system of FIG. 3A for displaying a 子 bubble on a display screen of the communication device;

FIG. 5A shows an illustrative representation of the bubble of FIG. 5 on the display screen of the communication device; and

系 FIG. 6 shows an alternative embodiment showing peer-to-peer communication between a plurality of communication devices embedded with the systems of FIG. 3A.

Detailed description of the invention

排

The invention described herein is explained using specific exemplary details for better understanding. However, the invention disclosed can be worked on by a person skilled in the art without the use of these specific details.

換 References in the specification to "one embodiment" or "an embodiment" means that a particular feature, structure, characteristic, or function described in connection with the embodiment is included in at least one embodiment of the invention. The appearances of the phrase `in one embodiment_ in various places in the specification are not necessarily all referring to the same embodiment.

References in the specification to `preferred embodiment_ means that a particular feature, structure, characteristic, or function described in detail thereby omitting known constructions and functions for clear description of the present invention.

系

The foregoing description of specific embodiments of the present invention has been presented for purposes of illustration and description. They are not intended to be exhaustive or to limit the present invention to the precise forms disclosed and obviously many modifications and variations are possible in light of the above

を

teaching.

Accordingly, the present invention discloses a system for displaying balance status and facilitating payment options via a communication device wherein the communication device automatically displays balance status and provides an option

を

for making payment through a predefined display layer thereof.

Referring to FIG. 1, an environment 100 tailored for the system of the present invention includes at least one communication device 110 that communicates with a wireless communication tower 120 and an operator network 130. The communication

を

device 110 communicates for a plurality of incoming services 140 and a plurality of outgoing services 150. The operator network 130 is in communication with a plurality of servers 160 as illustrated. In this one embodiment, the incoming services 140

include services such as USSD response after voice calling, USSD dialing response, USSD response after data disconnection, USSD response after SMS and the like. In

を

this one embodiment, the outgoing services 150 include services such as outgoing calls, dialed calls, USSD calls, SMS usage, Data usage, Credit Card services details retrieval, Banking services details retrieval and the like.

Referring to FIGS. 1 and 2, the communication device 110 includes a device controller 210, a device hardware 220, a device display 230, a device database 240, an operating system 250 and a microcontroller 260. In the context of the present invention, the microcontroller 260 is embedded with the system of the present invention such that the microcontroller 260 executes a plurality of instructions via the communication device 110 for a plurality of incoming and outgoing services 140, 150.

Referring to FIGS. 3A and 3B, a system 300 for displaying balance status and making payment via communication device 110 in accordance with the present invention is shown. The system 300 includes a front layer 305, a middle layer 310 and a back layer 315. The front layer 305 preferably defines a user interface that is accessible by the user for the plurality of incoming and outgoing services 140, 150. In this one embodiment, the front layer 305 displays various features on a display of the communication device 110 such as a balance display 332, a data display 334, a credit card status display 336, a bill statement display 338 and the like. The middle layer 320 includes a first activation module 342, a second activation module 344, a third activation module 346 and a fourth activation module 348. The back layer 315 includes a plurality of modules that selectively communicate with a system database 350 and a processor 352. The first activation module 342 communicates with the system database 350 and the processor 352 for activation of the balance display 332. The second activation module 344 communicates with the system database 350 and the processor 352 for activation of the data display 334. The third activation module 346 communicates with the system database 350 and the processor 352 for activation of the credit card status display 336. The fourth activation module 348 communicates with the system database 350 and the processor 352 for activation of the bill statement display 338.

As shown in FIG. 3B, the back layer 315 includes a plurality of modules namely a logic unit 354, a network detection module 356, a screen information capture module 358, a language module 359, a mobile device specification module 360, a dial mechanism 362, a display module 364, a SIM detection module 366, a listener/monitor module 368, an alert module 370, a user profile module 372, a billing unit 374, a service type detection module 376, a payment module 378 and a cross check module 380. It is understood here that the number of modules may vary in other alternative embodiments per intended application of the system 300.

30 The logic unit 354 is configured to analyse the information captured by the screen information capture module 358 using preconfigured data stored in the system database 350. The logic unit 354 arranges said information in a structured format through the processor 352 and saves the same as new information in the system database 350.

31 The network detection module 356 is configured to communicate with the Service Provider to detect connection network information and signal strength of the communication device 110. In particular, the network detection module 356 derives information such as roaming status, type of network, signal strength and the like. The network detection module 356 communicates with the system database 350 and SIM detection module 366 to decide accurate name of the connection network to which the communication device 110 is connected and subsequently stores said information in the system database 350.

32 The screen information capture module 358 is configured to check and authenticate the information received about various predefined credentials such as talk time balance status, data balance status, credit card bill status, saving/current account balance status and the like.

The language module 359 is configured to read a preconfigured language of the communication device 110 and accordingly communicate the same to the processor 352. The mobile device specification module 360 is configured to communicate with the processor 352 to investigate specification and compatibility of the communication device 110.

The dial mechanism 362 is configured to check credentials of the Service Provider such as network type, Service Provider type and data to be derived from a network Service Provider. It is understood here that the data to be derived from the network provider is selected in a form of an USSD query, an SMS or a dialing number. Accordingly, the dial mechanism 362 selects relevant number or a code from the system database 350 or from the user using the communication device 110 and accordingly decides a dialing mechanism or a messaging mechanism of the communication device 110 for execution of the query.

The display module 364 is configured to communicate with the processor 352 and the monitor module 368 and derives data from the system database 350. The display module 364 decides the type of data to be displayed on the display screen of the communication device 110. The display module 364 decides the form in which the data is to be displayed on the display screen of the communication device 110. The display module 364 decides a predefined place on the display screen of the communication device 110 at which the data is to be displayed. The display module 364 decides the time at which the data is to be displayed on the display screen of the communication device 110.

The SIM detection module 366 is configured to check and derive information about SIM present in the communication device 110 such as live/dead status of SIM, location of active SIM in the SIM slot, Service Provider of each available SIM, Unique Number of each SIM and the like. In addition, the SIM detection module 366

keeps a track of change/ removal of the pre-noted SIM from the SIM slot or installation of new SIM in the SIM slot of the communication device 110.

系 The monitor module 368 is configured to continuously monitor background actions being performed in the communication device 110. The monitor module 368 also continuously monitors the information from the controller 210, the database 240 and the operating system 250 in the communication device 110. The monitor module 368 analyses and compares this information with predefined trigger information from database 350 of the system 300. The monitor module 368 communicates with the system database 350 and the processor 352 and accordingly sends requests to show particular balance status via display module 364. The alert module 370 is configured to communicate with the processor 352 and the monitor module 368 if actual value of predefined credentials falls below a minimum set value.

系 The user profile module 372 analyses information of the user and stores the same in the system database 350 based on credentials such as gender of user, age of user, location of user, usage pattern, recharge pattern, calling pattern and the like. The user profile module 372 also stores previous communications received by the user on the communication device 110 from entities such as network Service Provider, Banks and other businesses. Accordingly, the user profile module 372 creates a user profile that helps the system 300 to predict and anticipate futuristic need of the user pertaining to services and products.

換 The billing unit 374 is configured to track usage of any type of service which is billable by the Service Provider. For example, the billing unit 374 keeps a track of the billable services such as voice calling service, internet data service, text message service and the like. The billing unit 374 communicates with the logic unit 354 and the cross check module 380 to collate and compare to prepare accurate bill of the billable services.

系 The service type module 376 is configured to decide the type of service of SIM namely a prepaid service or a postpaid service based communication with the network Service Provider. The service type module 376 communicates with the processor 352 to activate an appropriate activation process for the system 300 based on feedback received from the network Service Provider.

系 The payment module 378 includes an online payment mechanism interlinked with payment options such as bank payment or credit card payment, third party payment organization and the like. The payment module 378 includes processes to show best possible payment option to the user based on inputs received from the user profile module 372.

系 The cross check module 380 communicates with various modules such as the monitor module 372, the system database 350, the logic unit 354, the billing unit 374 and the processor 352 to predict information such as talk time balance usage, data balance usage, remaining talk time balance, remaining data balance, pending amounts, validity dates and the like.

系 Referring to FIGS. 3A, 3B, 4A and 4B, an activation process of the system 300 through the communication device 110 is shown. In a first step 402, specifications of the communication device 110 are identified through the mobile device specification module 360. The mobile device specification module 360 identifies compatibility of the communication device 110 with regard to various features such as Operating System, Random Access Memory, Screen type and the like. In next step 404, the system 300 checks type of hardware of the communication device 110. In particular, the system 300 identifies a type of processor in step 404 by communicating with the system database 350. In next step 406, the system 300 performs a SIM slot check to identify whether the communication device 110 includes a single SIM slot or multiple

SIM slots. In next step 408, the system 300 performs actual SIM check wherein SIM is identified by firing a query to the processor 352. In further step 410, information related to SIM is extracted and compared with the information stored in the system database 350 in next step 412. In step 412, a Service Provider is decided based on an output obtained after comparison. In next step 414, the system 300 performs SIM status check wherein the network detection module 356 communicates with the Service Provider to detect network information. In step 414, the SIM detection module 366 performs network strength and mobile signal check in order to confirm whether SIM is dead or alive. In next step 415, the language module 359 is activated. The language module 359 reads a preconfigured language of the communication device 110 and accordingly communicates the same to the processor 352 such that the processor 352 coordinates the activation process as per the preconfigured language of the communication device 100. In next step 416, an authentication access to the system 300 is performed wherein data/ user actions are authorized. In step 418, the system 300 decides the type of service subscription or service type that is typically based on user input. It is understood here that step 418 is performed manually or automatically by firing a query to the Service Provider. In next step 420, the monitor module 368 is activated. The monitor module 368 continuously monitors further process after activation thereof. In next step 424, the service type detection module 376 decides the type of service as prepaid or postpaid based on feedback received from the Service Provider and accordingly moves to next step 424 based on postpaid/prepaid service type selection. In step 424, the dial mechanism 362 is activated which fires a query to get balance status of the SIM. In next step 426, the received information about balance status is authenticated by the screen information capture module 358 wherein the system 300 checks which application has provided the information based on tags and accordingly confirms the information received in previous steps. Accordingly, the activation process moves from the step 426 to a step 428 if the information is authenticated from the operator. In step 428, the processor 352 activates the logic unit 354 and records a first talk time balance. In next step 430,

the system database 350 stores the first talk time balance and time and communicates the same to the monitor module 368. In next step 432, a user profile is created by the user profile module 372 and information of the user is stored in the system database 350. In step 434, the system 300 identifies and captures dialer information in form of a predefined display layer and stores the same in the system database 350. In step 436, the processor 352 activates the predefined display layer.

In step 438, the display layer automatically creates a bubble on the predefined dialer at a predefined position on a display screen of the communication device 110 and displays the same in step 440. In this one embodiment, the predefined dialer is a screen or a notification panel of the communication device 110. It is understood here that the user may decide the predefined position of the bubble by manually moving the bubble within the boundary defined by the screen of the communication device 110. In the context of the present invention, the bubble displays latest credentials of the system 300 such as a talk time balance, a data balance, a credit card balance, bill amount, account balance and the like. Accordingly, the process of bubble activation and display is performed. In further step 442, the first time balance activation process is repeated for multiple SIMs, if any, thereby following sequential steps from step 402 to step 440.

After first time activation, the monitor module 368 of the system 300 continuously monitors and updates predefined credentials on the bubble, such as talk time balance, data balance, credit card balance, bill amount, account balance and the like. The monitor module 368 communicates with the processor 352 to activate the alert module 370 if actual value of the predefined credentials falls below a minimum set value. The alert module 370 provides a message alert on the communication device 100 if actual value of the predefined credentials falls below a minimum set value. This allows the communication device 110 to take necessary actions, such as balance recharge, data recharge and the like.

Referring to FIGS. 5 and 5A, a bubble screen mechanism 500 in accordance with the present invention is shown. The bubble screen mechanism 500 is configured to be implemented on the communication device 110 in the context of the present invention. The bubble display mechanism 500 includes a base layer defined by the system 300 embedded on the microcontroller 260 of the communication device 110. The bubble screen mechanism 500 includes a middle layer defined by a display screen 510 of the communication device 110. The bubble screen mechanism 500 includes a top layer defined by a secondary screen 520. The secondary screen 520 includes a bubble 530 that is positioned at a predefined location over the display screen 510. However, it is understood that the bubble 530 is manually movable over the display screen 510.

Referring to FIG. 6, an alternative embodiment of the system 300 adapted for displaying balance status and making payment for balance communication between a plurality of communication devices 610 is shown. In this one alternative embodiment, the system 300 of the present invention is pre-installed on the microcontroller 260 of the plurality of communication devices 610 in order to facilitate communication between said communication devices 610 through a system server 620. In this one alternative embodiment, at least one communication device 610 acts as a primary device and at least one communication device 610 acts as a secondary device such that the secondary device 610 is configured to share its authentication credentials to the primary device 610 for authentication. It is understood here that the authentication credentials being authenticated by the primary device 610 are contact number and/or device name in this one embodiment. Further, it is understood that the primary device 610 performs authentication based on requests received for authentication from the secondary device 610. Accordingly, the plurality of primary and secondary devices 610 may connect through the system server 620 thereby forming a group. The system server 620 is in communication with each communication device 610 in order to monitor predefined credentials, such as talk time balance, data balance and the like.

The primary device 610 receives an alert from the system server 620 if actual value of the predefined credentials in the secondary device 610 falls below a minimum set value. This allows the primary device 610 to take a plurality of necessary actions with regard to various actions, such as a balance recharge, a data recharge, a credit card payment, a third party payment and the like.

The embodiments were chosen and described in order to best explain the principles of the present invention and its practical application, to thereby enable others, skilled in the art to best utilize the present invention and various embodiments with various modifications as are suited to the particular use contemplated.

It is understood that various omission and substitutions of equivalents are contemplated as circumstance may suggest or render expedient, but such are intended to cover the application or implementation without departing from the spirit or scope of the present invention.

Claims :

1) A system for displaying balance status and making payment via a communication device, said system comprising:

系 a microcontroller having a processor, a system database and a plurality of modules configured thereon;

子 a monitor module configured to monitor a plurality of background actions being performed by the communication device, the monitor module configured to constantly monitor information received from a controller, a database and an 子 operating system of the communication device, the monitor module configured to analyse and compare said information with a predefined trigger information from the system database for displaying a latest updated value of a plurality of predefined credentials;

子 a display module configured to communicate with the processor, the system 子 database and the monitor module for deriving a predefined data from the system database; the display module configured to actuate a bubble display mechanism, the bubble display mechanism configured to form a secondary screen on a predefined display layer of the communication device, the secondary screen having a bubble configured thereon, the bubble configured to be located at a predefined location for a 子 predefined time on the predefined display layer, the bubble configured to display a latest value of the predefined credentials on the predefined display layer;

a screen information capture module configured to capture information available on display screen of the communication device to further communicate with the system database for authenticating the predefined credentials; and

子 a logic unit configured to analyse an information captured by the screen information capture module using a preconfigured data in the system database;

an alert module configured to communicate with the processor and the monitor module, the alert module configured to generate an alert message; and

a language module configured to communicate with the processor, the language module configured to select and communicate in a preconfigured language of the communication device.

- 系 2) The system as claimed in claim 1, wherein the plurality of predefined credentials include a talk time balance, a data balance, a credit card balance, a bill amount, an account balance and the like.
- 3) The system as claimed in claim 1, wherein the alert module generates an alert message if actual value of the predefined credentials falls below a minimum set value.
- 3) The system as claimed in claim 1, wherein the bubble is manually movable within a predefined boundary defined by the predefined display layer.
- 系 5) The system as claimed in claim 1, wherein said system includes a user profile module configured to analyse and store information of the user based on a plurality of user credentials.
- 6) The system as claimed in claim 5, wherein the plurality of user credentials include information such as a gender of user, an age of user, a location of user, a usage pattern, a recharge pattern, a calling pattern and the like.
- 7) The system as claimed in claim 1, wherein said system includes a network detection module configured to communicate with a service provider for detection of network information of the communication device.
- 8) The system as claimed in claim 1, wherein said system includes a mobile device specification module configured to communicate with the processor to investigate specification and compatibility of the communication device.

9) The system as claimed in claim 1, wherein said system includes a dial mechanism configured to dial a predefined or user given code or number to check a network type, a service provider type and a data type to be derived from the network
系 Service Provider.

10) The system as claimed in claim 1, wherein said system includes a SIM detection module that is configured to check and derive SIM status information about SIM in the communication device.

系

11) The system as claimed in claim 1, wherein said system includes a billing unit configured to track usage of billable services provided by the service provider.

12) The system as claimed in claim 1, wherein said system includes a service type
系 detection module configured to communicate with the service provider to decide a type of service being provided by the service provider.

13) The system as claimed in claim 1, wherein said system includes a payment
系 module configured with an online payment mechanism to show a plurality of payment options to the user.

14) The system as claimed in claim 1, wherein said system includes a cross check
系 module configured to communicate with the plurality of modules to analyze and predict information such as talk time balance usage, data balance usage, remaining talk time balance, remaining data balance, pending amounts, validity dates and the like.

15) A method for displaying balance status and making payment via a communication device, said method comprising the steps of:

identifying specifications of the communication device by a mobile device specification module for checking compatibility thereof;

checking type of a hardware of the communication device by communicating with a system database;

系 performing SIM slot check for identifying quantity of SIM slots in the communication device;

performing actual SIM check by extracting and comparing SIM information of the communication device with a preconfigured information in the system database;

孔 activating a network detection module thereby communicating with the service provider to detect network information;

activating a language module to read a preconfigured language of the communication device;

authenticating access to a plurality of actions pertaining to the user and data;

系 deciding a service subscription type based on the user input;

activating a monitor module for constantly monitoring a plurality of background actions being performed by the communication device;

activating a dial mechanism on a predefined screen to obtain balance status of the SIM in the SIM slot;

机 authenticating a balance status information by an information capture module;

storing the captured information in system database;

activating a logic unit for analyzing captured information and for recording a first balance of a plurality of predefined credentials followed by storing said first balance in the system database;

換 creating a user profile by a user profile module followed by storing the user profile information in the system database;

identifying and capturing a dialer information in form of a predefined display layer followed by storing said dialer information in the system database;

activating the predefined display layer through the processor;

creating a bubble at a predefined position on the predefined display layer of the dialer thereby displaying a latest value of the plurality of predefined credentials;

updating the latest value of the predefined credentials by logic unit and monitoring module followed by displaying the latest value of the predefined credentials on the bubble;

creating an alert message through an alert module if actual value of the predefined credentials falls below a minimum set value; and

facilitating a plurality of payment options on the communication device based on the alert message.

30

16) The method as claimed in claim 15, wherein the actual SIM check is performed by firing a query to the processor.

31 17) The method as claimed in claim 15, wherein the network detection module performs network strength and mobile signal check.

18) The method as claimed in claim 15, wherein the SIM detection module checks and confirms whether SIM is dead or alive or changed by the user.

32 19) The method as claimed in claim 15, wherein the service subscription type is decided manually or automatically by firing a query to the service provider.

20) The method as claimed in claim 15, wherein the service type detection module detects service as a prepaid service or a postpaid service.

33

21) The method as claimed in claim 15, wherein the plurality of predefined credentials include talk time balance, data balance, credit card balance, bill amount, account balance and the like.

22) The method as claimed in claim 15, wherein the predefined screen includes a dialer, an SMS inbox, a screen of a website or other relevant screen in the system database.

系 23) The method as claimed in claim 15, wherein the bubble is manually movable within a boundary defined by the predefined display layer of the communication device.

24) A peer-to-peer communication method for balance communication between a plurality of communication devices, the peer-to-peer communication method comprising:

- 系 installing a microcontroller on at least one primary device;
- 系 installing a microcontroller on at least one secondary device;
- 系 facilitating a communication between the primary and secondary devices through a system server;
- 系 configuring the secondary device for sharing a plurality of authentication credentials to the primary device thereby communicating with the system server;
- 系 configuring the primary device for authenticating the plurality of authentication credentials thereby communicating with the system server;
- 系 facilitating the primary and secondary devices to form a group through the system server;
- 系 monitoring the predefined credentials of the primary and secondary devices thereby generating an alert message if actual value of the predefined credentials of the secondary device falls below a minimum set value;
- 系 conveying the alert message to the primary device through the system server;
- and
- 系 facilitating the primary device to take a plurality of necessary actions with regard to the secondary device through the system server.

25) The method as claimed in claim 24, wherein the microcontroller includes a processor, a system database and a plurality of modules configured thereon.

26) The method as claimed in claim 24, wherein the plurality of modules include a logic unit, a network detection module, a screen information capture module, a language module, a mobile device specification module, a dial mechanism, a display module, a SIM detection module, a monitor module, an alert module, a user profile module, a billing unit, a service type detection module, a payment module and a cross check module.

27)

The method as claimed in claim 24, wherein the plurality of necessary actions include a balance recharge, a data recharge, a credit card payment, a third party payment and the like.

28)

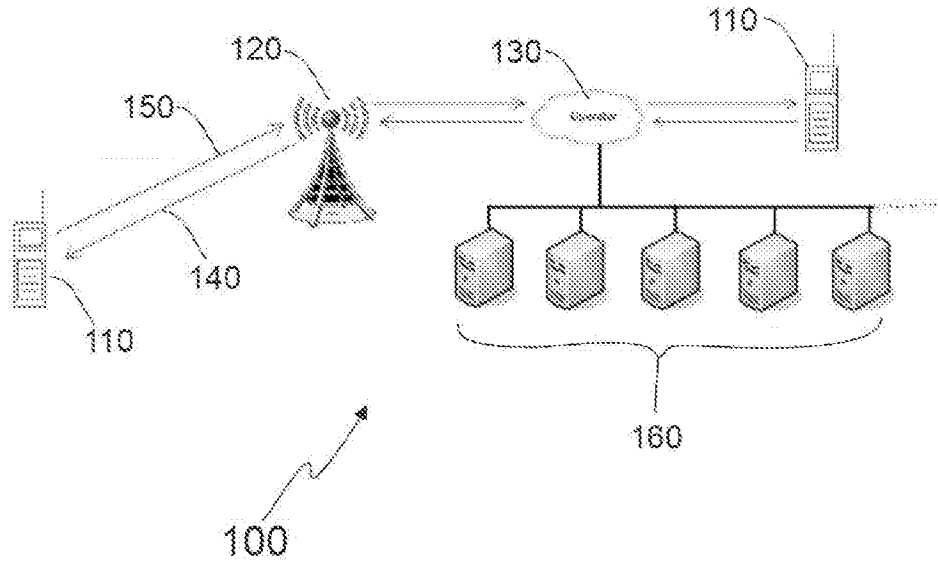

FIG.1

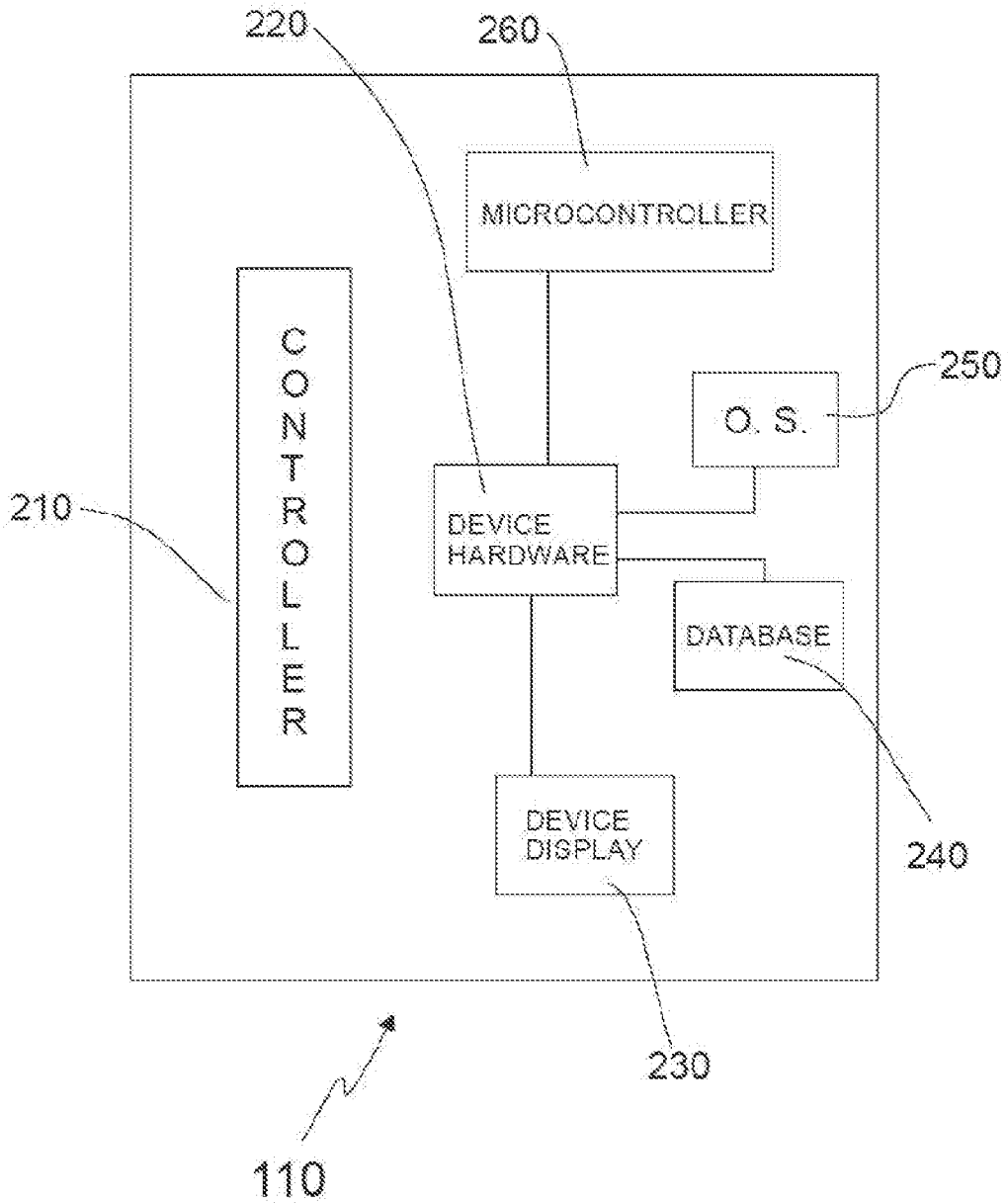

FIG. 2

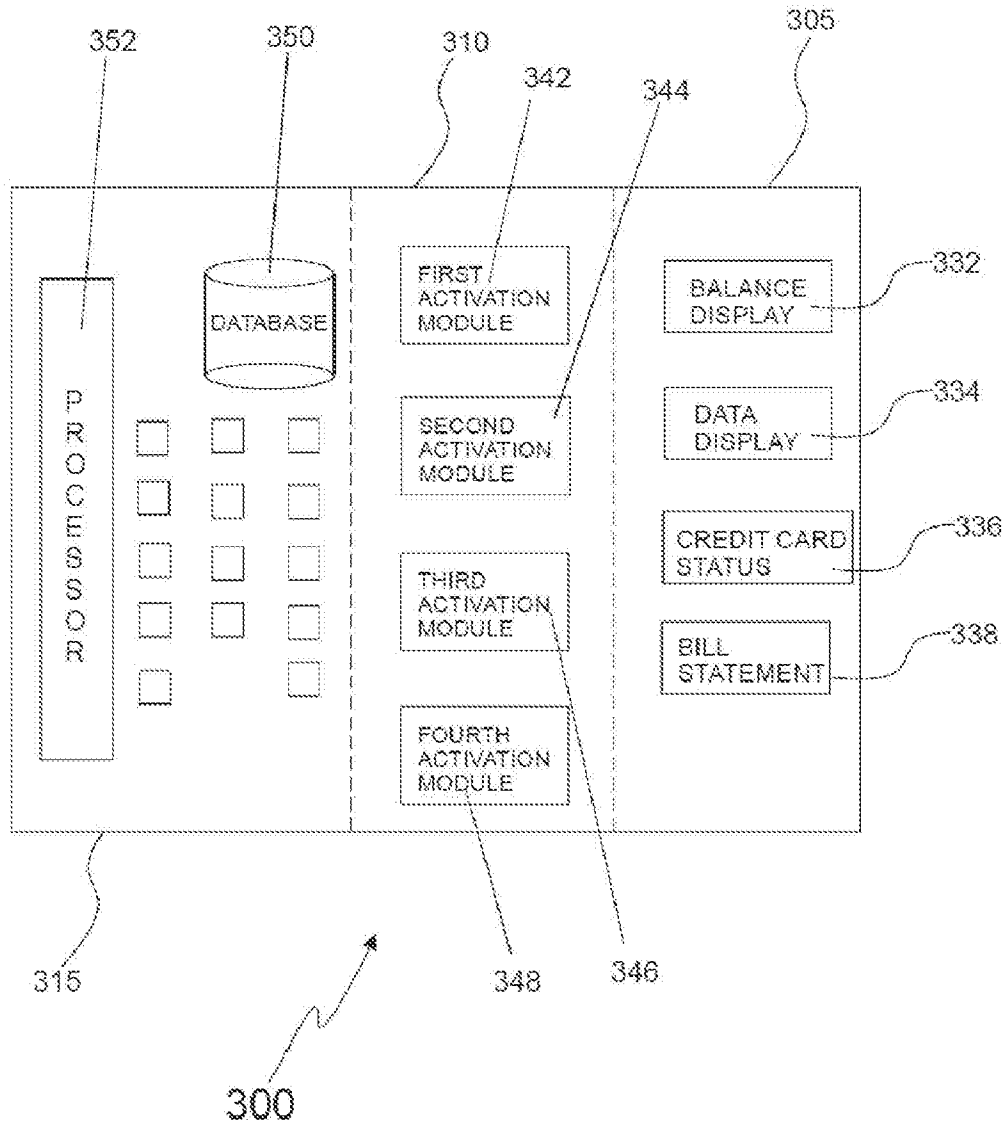

FIG. 3A

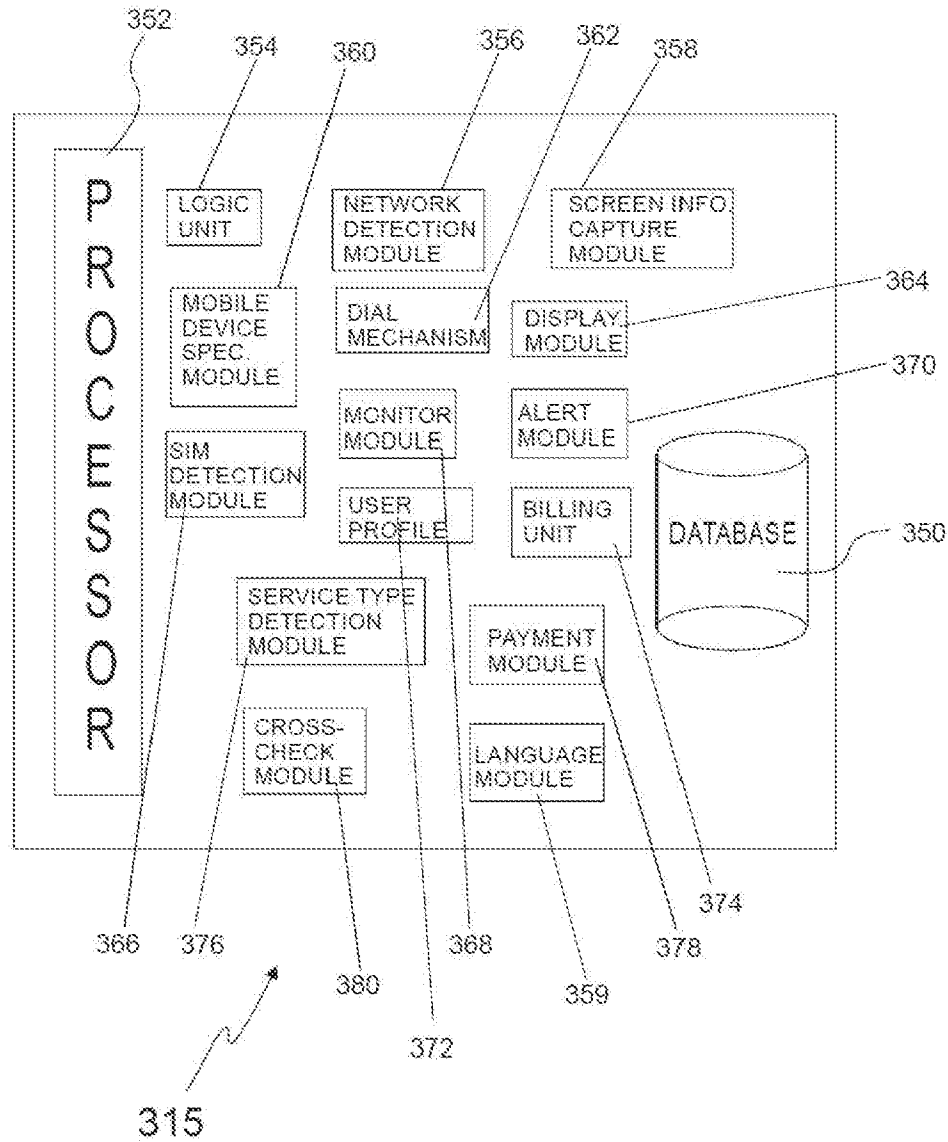

FIG. 3B

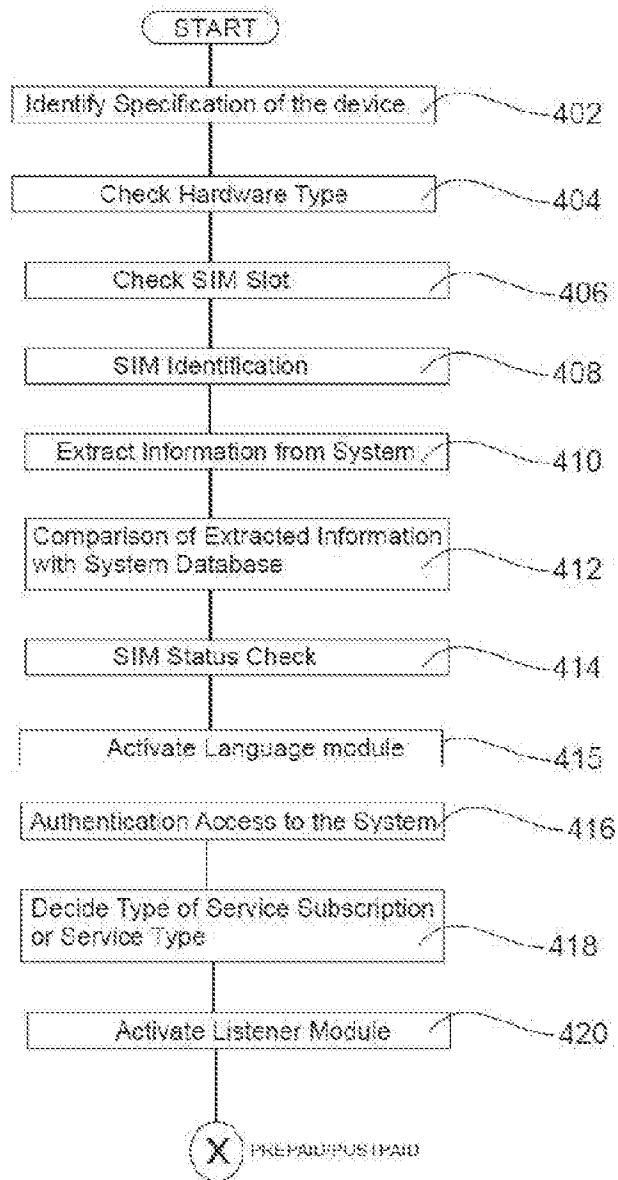

FIG. 4A

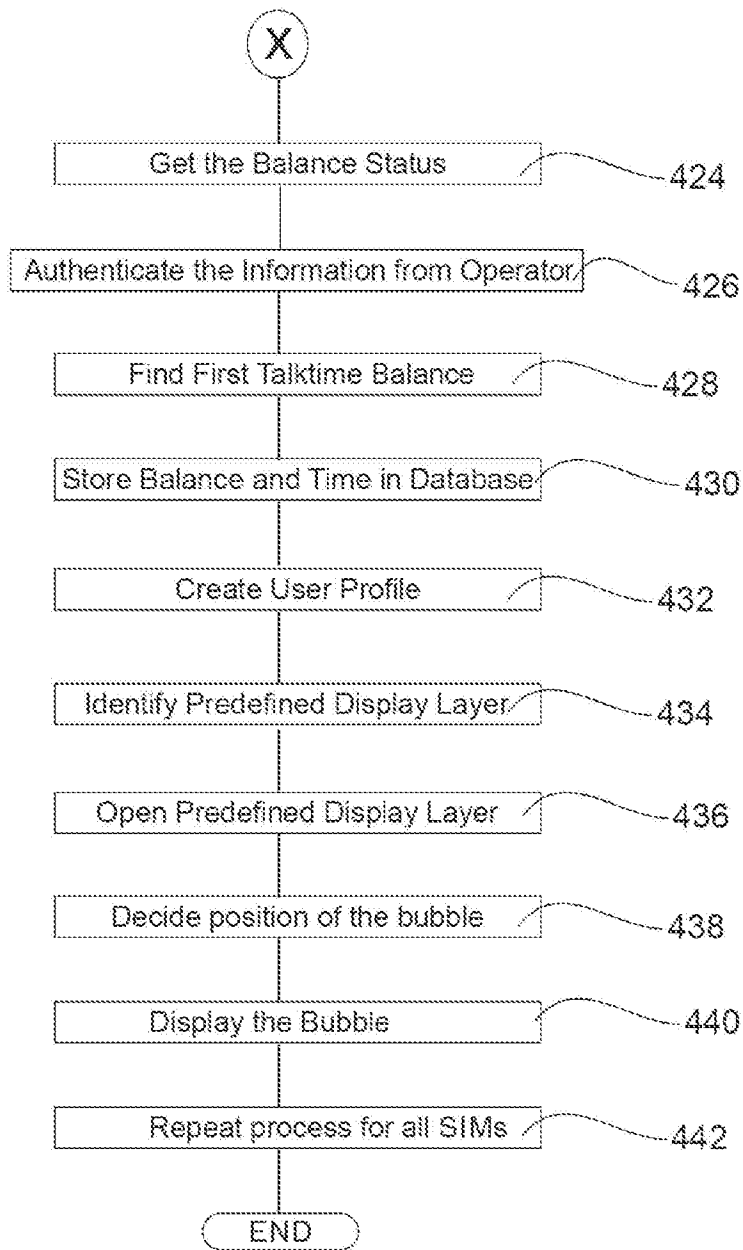

FIG. 4B

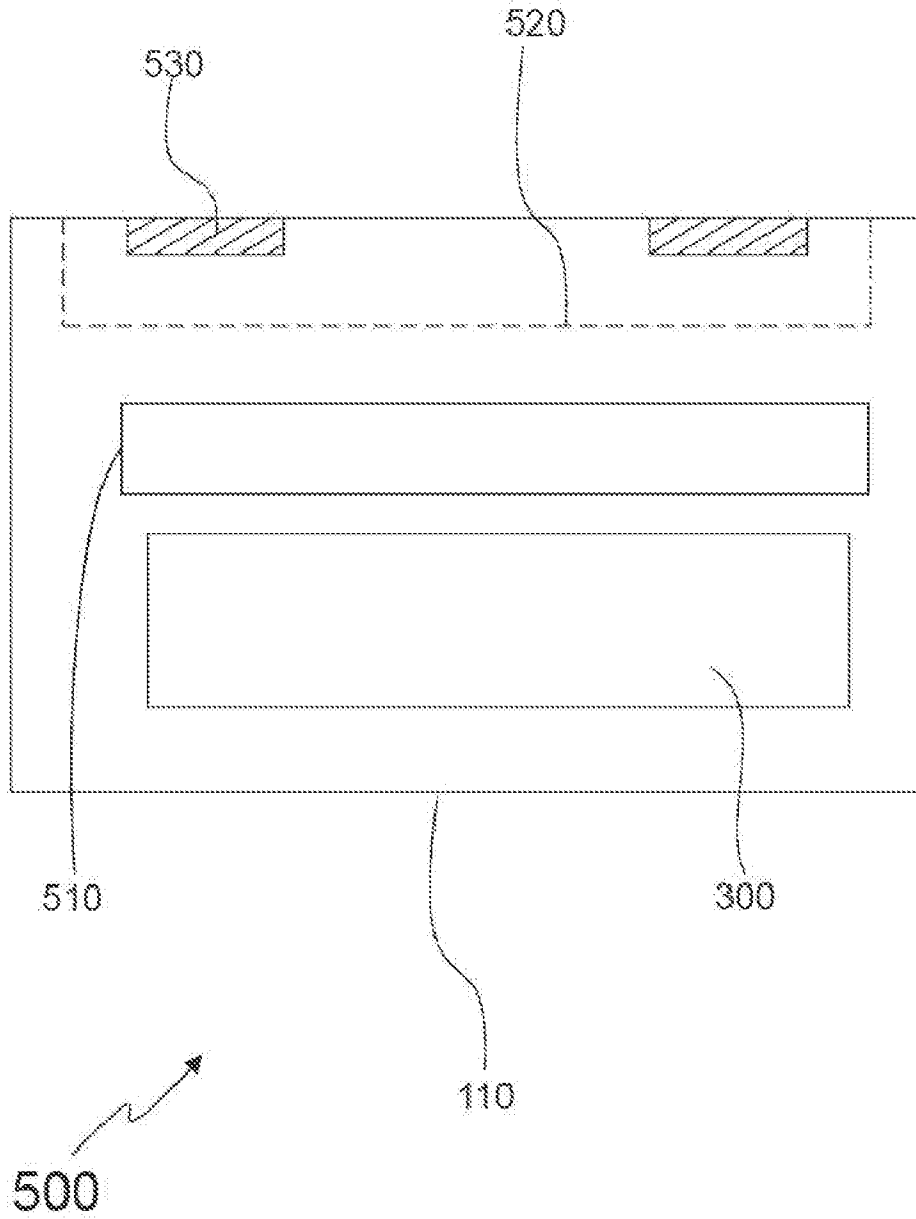

FIG. 5

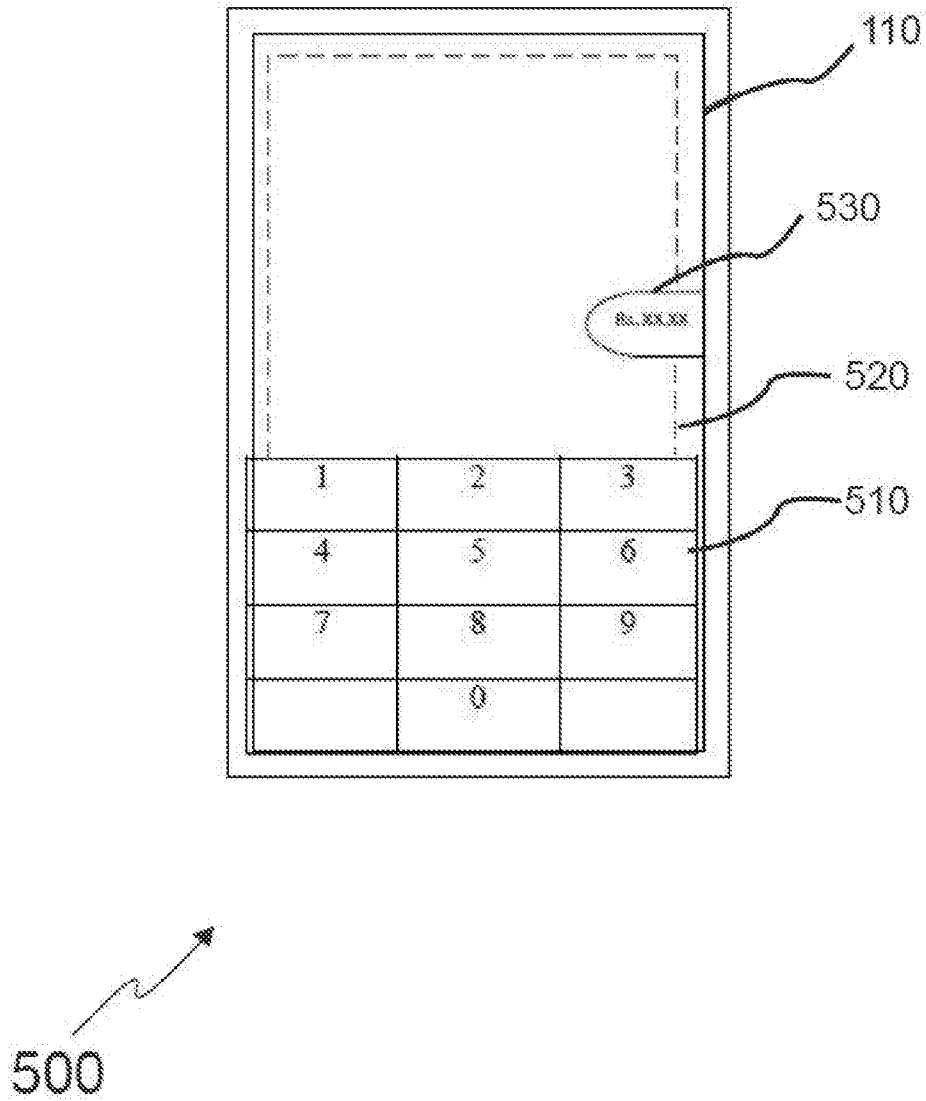

FIG. 5A

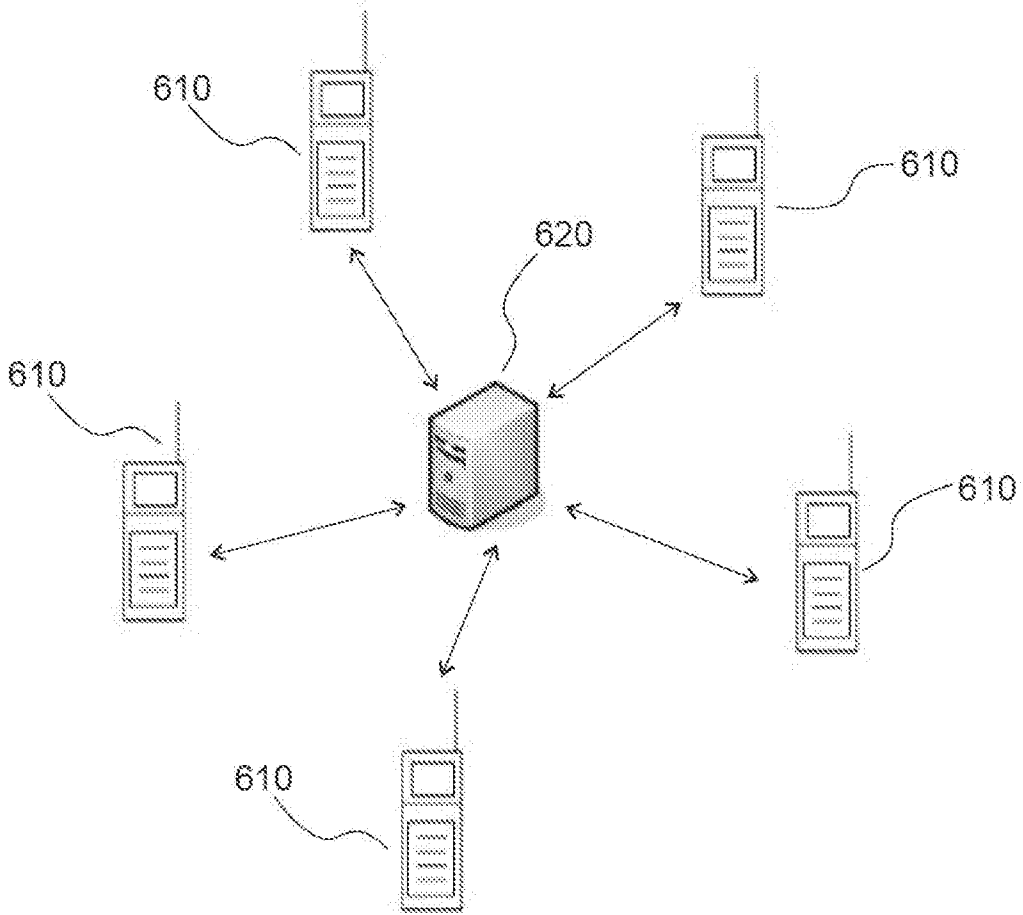

FIG. 6