

(No Model.)

C. A. LAMB.
RAILWAY SIGNAL.

No. 335,821.

Patented Feb. 9, 1886.

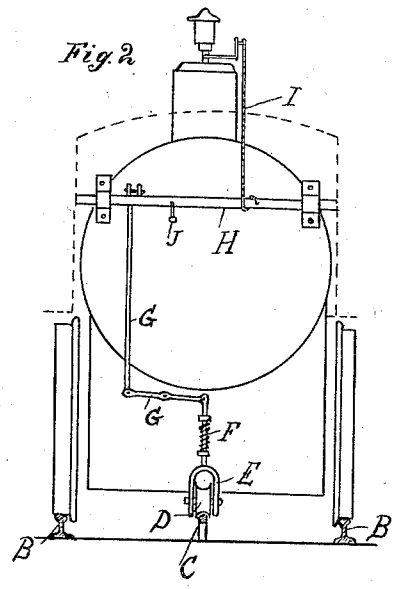
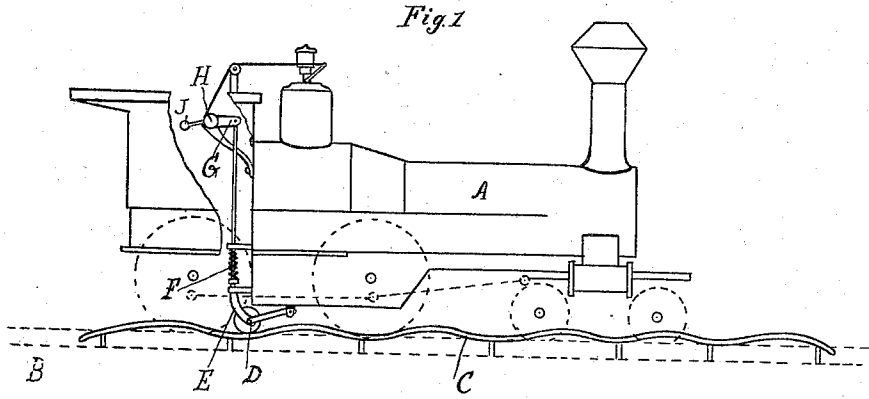

Attest:
John Schuman.
W. Sprague

Inventor:
Charles A. Lamb.
by his atty
Wm. S. Sprague

UNITED STATES PATENT OFFICE.

CHARLES A. LAMB, OF DEER CREEK, MICHIGAN.

RAILWAY-SIGNAL.

SPECIFICATION forming part of Letters Patent No. 335,821, dated February 9, 1886.

Application filed July 23, 1885. Serial No. 172,415. (No model.)

To all whom it may concern:

Be it known that I, CHARLES A. LAMB, of Deer Creek, in the county of Livingston and State of Michigan, have invented new and useful Improvements in Railway-Signals; and I do hereby declare that the following is a full, clear, and exact description thereof, reference being had to the accompanying drawings, which form a part of this specification.

This invention relates to certain new and useful improvements in attachments to locomotives of that class designed and arranged to automatically blow the whistle at crossings and other points where it may be deemed necessary.

The invention consists in the peculiar combinations and the novel construction and arrangement of parts, as hereinafter more fully described and claimed.

Figure 1 shows the outline of a locomotive with my improvements arranged relatively thereto. Fig. 2 is a rear elevation.

In the accompanying drawings, which form a part of this specification, A represents a locomotive, and B the main rails of a track. Located between the main rails B and at suitable and desirable points along the line of the road is an undulating rail, C.

D is a grooved wheel or pulley properly journaled in a bracket or hanger, E, provided with a spring, F, arranged to keep the pulley in contact with the rail C. The upper end of the hanger E is connected by a system of levers, G, to a rock-shaft, H, which is journaled in proper bearings at the desired point in the locomotive, and from this rock-shaft there is a connection made by means of a rope, I, with the whistle-lever.

In practice as the locomotive approaches the crossing the grooved wheel D rises upon the face of the undulating rail C, which, by the connections herein shown, imparts a vibrating rocking motion to the shaft H, in turn partially winding and unwinding the cord I upon it, necessarily opening and closing the whistle-valve, thereby giving the danger-signal in a succession of "toots."

A hand-lever, J, is secured to the rock-shaft H, by means of which the whistle may be blown by the engineer at points between the undulating rails.

I deem it important that the rock-shaft H be placed within convenient reach of the engineer from the cab, and that it be provided with a hand-lever, as shown, so that in case

the signal fail to work, or if, as it sometimes happens, the engineer desires to blow the whistle at any time between the signals, he can easily do so by simply turning the rock-shaft by means of said hand-lever. The same shaft thus serves for both purposes.

I am aware that vertically-adjustable corrugated bars have been arranged along one side of the track, and that means have been provided for raising or lowering said bars to throw them into either an operative or inoperative position, and such I do not claim.

I deem it important that the undulating rail C be arranged midway of the rails, whereby the signal may be given with the train moving in either direction, which on single-track roads will be found a decided advantage over those constructions in which the corrugated rail is arranged by the side of the track. I also deem it important that the rail C be stationary and rigidly secured in its position midway between the rails, thus dispensing with the levers and complicated devices heretofore employed for throwing the rail up into an operative position. It is thus always in position to operate the whistle, and thus avoids the liability of failure to give the signal, which is apt to occur from breakage or derangement of the devices used for throwing the rail up into operative position.

What I claim as my invention is—

1. The combination, with the stationary undulating rail C, of the hanger E, the grooved wheel D, journaled therein, the spring F, arranged on said hanger and adapted to keep said wheel in contact with the rail C, the rock-shaft H, levers G, and cord I, all substantially as and for the purpose specified.

2. The combination, with the undulating rail C, of the locomotive A, hanger E, supported thereon, roller or wheel D, carried by said hanger, the rock-shaft H, journaled in bearings within reach of the cab, levers G, connecting said hanger and rock-shaft, and the cord I, connecting said rock-shaft with the whistle of the locomotive, said rock-shaft being provided with a hand-lever, J, substantially as and for the purposes specified.

In testimony that I claim the above I have hereunto set my hand this 25th day of May, 1885.

Witnesses: CHAS. A. LAMB.
H. S. SPRAGUE,
E. J. SCULLY.