

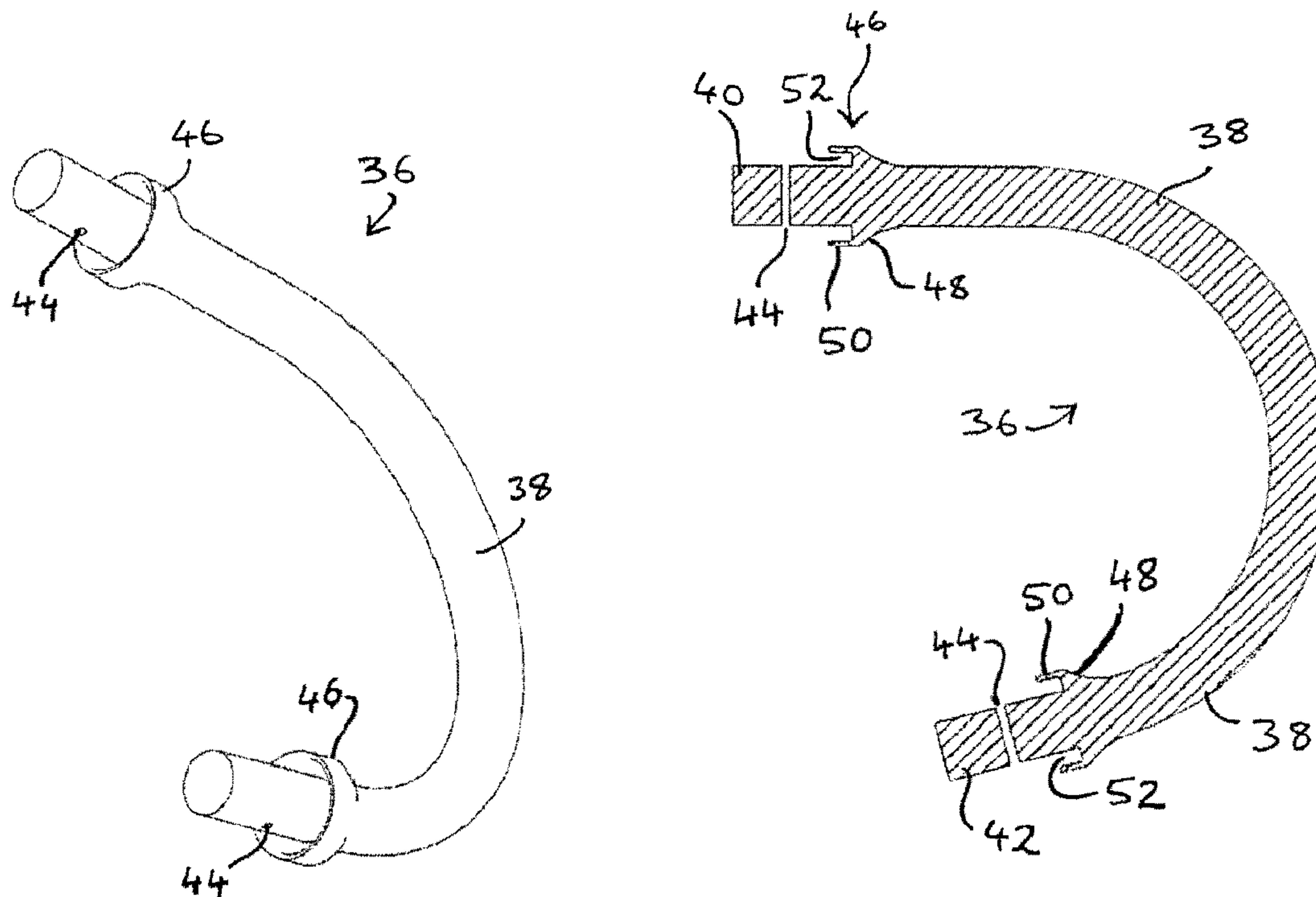

(22) Date de dépôt/Filing Date: 2014/12/12  
 (41) Mise à la disp. pub./Open to Public Insp.: 2015/06/13  
 (45) Date de délivrance/Issue Date: 2017/09/12  
 (30) Priorité/Priority: 2013/12/13 (GB1322068.6)

(51) Cl.Int./Int.Cl. *A01K 1/00* (2006.01)  
 (72) Inventeur/Inventor:  
 EARLS, MICHAEL, IE  
 (73) Propriétaire/Owner:  
 EARLS, MICHAEL, IE  
 (74) Agent: BLAKE, CASSELS & GRAYDON LLP

(54) Titre : COMPOSANTS BARRIERES POUR STALLES ANIMALIERES  
 (54) Title: BARRIER COMPONENTS FOR ANIMAL STALLS



(57) Abrégé/Abstract:

A barrier component is disclosed for an animal stall, comprising a curved, elongated body member of elastomeric material such as rubber. This body member has first and second end sections each adapted for engagement within a respective hollow pipe. Together the two hollow pipes and the barrier component provide a stall divider when mounted on a suitable set of brackets, poles or supports at the head end of a stall. The component has a collar formation at each end which defines an annular recess for receiving a hollow pipe end and shielding the end of the pipe from the animal.

**1 ABSTRACT**

2           A barrier component is disclosed for an animal stall, comprising a curved, elongated  
3 body member of elastomeric material such as rubber. This body member has first and second  
4 end sections each adapted for engagement within a respective hollow pipe. Together the two  
5 hollow pipes and the barrier component provide a stall divider when mounted on a suitable set  
6 of brackets, poles or supports at the head end of a stall. The component has a collar formation  
7 at each end which defines an annular recess for receiving a hollow pipe end and shielding the  
8 end of the pipe from the animal.

1 **Barrier Components for Animal Stalls**

2 **Technical Field**

3 This invention relates to stalls or cubicles for animals.

4 **Background Art**

5 Farm animals are frequently accommodated indoors using stalls (also referred to as cubicles or  
6 pens; the term "stalls" will be used herein). One common design of stall has a common head  
7 barrier or wall with parallel dividers projecting out to define individual spaces for animals  
8 between a pair of adjacent dividers.

9 Typical steel stall dividers are a basic U shape made of one piece of steel tubing bent to make  
10 the U shape. The ends of the "U" are mounted to the head end barrier (i.e. with the "U" lying on  
11 its side) and with the bottom of the "U" projecting outwards. These dividers cause injuries to the  
12 animals.

13 One solution is to replace the stainless steel divider with a pair of flexible plastic pipes, replacing  
14 the upper and lower rails of the steel "U" shape. Easyfix Limited, of Ballinasloe, Ireland supply  
15 such a product employing hollow polypropylene random (PP-R) co-polymer pipes, which  
16 provide a safe replacement for the conventional steel stall dividers and eliminate possible  
17 injuries to animals.

18 One problem encountered with this solution was that because the PP-R pipe stall system uses  
19 two open ended pipes, when young animals or animals, which were not used to a stall system,  
20 first entered the stall there was a chance of them being able to turn around in the stall and end  
21 up facing the wrong way.

22 It is not practical to bend an extruded PP-R pipe into a U-shape as the pipe has to be heated  
23 evenly all the way through its 12.5mm wall thickness. This would require a huge oven capable  
24 of taking several 4 meter lengths of pipe and then bending them in a press big enough to press  
25 them into shape and hold that shape while they cooled. Such a process would be cost  
26 prohibitive.

27 A further drawback of recreating the steel U-shape with PP-R material is that the resultant  
28 product loses the flexibility inherent in having a pair of pipes freely projecting from a single  
29 mounting point. If created in a U shape, the PP-R pipe would be too rigid a product.

30

1 **Disclosure of the Invention**

2 In a first aspect there is provided a barrier component for an animal stall, comprising:

3 a curved, elongated body member of elastomeric material, the body having first and  
4 second end sections;

5 the first end and the second end sections each being adapted for engagement within a  
6 hollow pipe; and

7 a collar formation adjacent the first end or the second end which defines an annular  
8 recess for receiving a hollow pipe end.

9 Creating a barrier component, for fitting to a pair of hollow pipe ends, from an elastomeric  
10 material, provides a number of benefits.

11 A U-shaped barrier can be created from a pair of lightweight polymer (e.g. PP-R) pipes which  
12 are mounted to a head end mounting such as a head-end barrier or a wall bracket, and the  
13 barrier component of the invention, resulting in a divider which is significantly less rigid than  
14 either a steel U section or a U shaped barrier formed of PP-R pipe (or similar polymers).

15 The component allows the two existing pipes to flex almost independently of one another and it  
16 also brought an added safety factor for the animals in that there is absolutely no danger of the  
17 animals getting bruised when entering the stall, or even if they brush past the outside of the stall  
18 while using the access passageway.

19 The component also prevents injury to the animals in the stall as it will stretch if an animal is  
20 panicked while in the stall. Additionally it is practical and cost effective to manufacture and can  
21 be attached relatively simply using bolts or other fasteners that can be simply passed through  
22 the plastic pipe and the ends of the component received in the pipe.

23 The collar provides an annular recess which accommodates the end of the pipes and thereby  
24 protects the animal when entering the stall from injury against the edge of the pipe ends, and  
25 also prevents animals from using the pipe end as a scratching post. Furthermore, by  
26 accommodating the pipe end within the recess, dirt is prevented from entering the pipe.

27 The collar serves the further function of continuing to protect the pipe end even if the component  
28 is severely stretched.

29 Preferably, said curved, elongated body subtends an angle of between 90 and 220 degrees,  
30 more preferably 140 and 180 degrees, even more preferably between 150 and 175 degrees.

1 Preferably, said body is generally cylindrical along its length and has a first diameter in a middle  
2 section thereof, the first and second ends having a second diameter which is less than the first  
3 diameter.

4 The middle section preferably occupies the major part of the length of the component.

5 Preferably, the collar comprises a flared formation which increases in diameter towards the end  
6 section to which it is adjacent.

7 Preferably, the flared formation increases in diameter from the first diameter where it merges  
8 with the middle section to a third diameter greater than the first diameter, the increase in  
9 diameter being continuous rather than abrupt.

10 Preferably, the collar further comprises an annular skirt projecting axially from the flared section  
11 towards the end section to which the collar is adjacent, the skirt and the end section defining  
12 between them said annular recess.

13 Most preferably, two of said collars are provided, one adjacent each end section.

14 The end sections are preferably provided with a through hole to receive a locking member.

15 In a preferred embodiment, the elastomeric material is vulcanised moulded rubber.

16 There is also provided a barrier assembly for an animal stall comprising the barrier component  
17 described above, and first and second pipes each having a hollow free end, wherein the free  
18 ends of the first and second pipes receive a respective one of the first and second ends of the  
19 barrier component, such that the curved elongated body member connects the first and second  
20 pipes.

21 There is further provided an animal stall assembly comprising a plurality of said barrier  
22 assemblies mounted parallel to one another along a central barrier such that the barrier  
23 assemblies are spaced apart from one another and each adjacent pair of barrier assemblies  
24 defines a respective animal stall, the first and second pipes of each barrier assembly being  
25 generally mounted one above the other and the barrier component of each barrier assembly  
26 being disposed at an outer end of the stall away from the central barrier.

27 In a further, independent aspect of the invention, there is provided a stall divider for animal  
28 stalls, comprising:

29 first and second pipes each having a head end adapted for mounting on a fixed  
30 head-end barrier, whereby in use said pipes extend from said head end to a free end,

1 the pipes lying within and defining a substantially vertical plane which separates a pair of  
2 neighbouring stalls; and

3 a connecting member comprising a curved length of flexible material having first  
4 and second ends, the first and second ends being adapted for mounting in the free ends  
5 of the first and second pipes, respectively.

6 Preferably, said first and second pipes are made of PP-R (polypropylene random copolymer).

7 The connecting member preferably comprises a solid flexible tube extending in a curved fashion  
8 from the free end of the first pipe to the free end of the second pipe.

9 Preferably, the connecting member is secured to the free ends by being inserted into a hollow  
10 terminal portion at the free end of each pipe, and being secured by a bolt extending through the  
11 free end and the connecting member.

## 12 **Brief Description of the Drawings**

13 The invention will be further illustrated by the following description of embodiments thereof,  
14 given by way of example only with reference to the accompanying drawings, in which:

15 Fig. 1 is a perspective view of a layout of an animal house containing a set of stalls;

16 Fig. 2 is a detail of Fig. 1;

17 Fig. 3 is a perspective view of a barrier component of one animal stall divider  
18 assembly;

19 Fig. 4 is a front elevation of the barrier component of Fig. 3;

20 Fig. 5 is a sectional elevation of the barrier component of Fig. 3, along the line V-V in  
21 Fig. 4;

22 Fig. 6 is a rear elevation of the barrier component of Fig. 3;

23 Fig. 7 is a plan view from below of the barrier component of Fig. 3; and

24 Fig. 8 is a side elevation of the barrier component of Fig. 3.

25 In Fig. 1 there is indicated, generally at 10, an animal house layout containing an animal stall  
26 assembly 12 with a plurality of animal stalls 14 arranged in two rows 16, 18.

27 Referring additionally to Fig. 2, a detail of the Fig. 1 layout is shown, including a series of cubicle  
28 posts 20 mounted along a centre line 22 of the animal house. The endmost post 20 is shown

1 without any barrier or stall divider, and it can be seen that the post is provided with a pair of  
2 upper mounting posts 24 and a pair of lower mounting posts 26. As seen with the next adjacent  
3 post 20, the upper mounting posts (not visible) are used to each mount a respective upper  
4 barrier pole 28 which extend horizontally outward from one another, while the lower mounting  
5 posts (not visible) are used to each mount a respective lower barrier pole 30 which extend  
6 outward from one another in the same vertical plane as the upper posts 28, but inclined  
7 upwardly at an angle of 15 degrees.

8 Lengthwise head-end rails, known as neckrails 32, are tied to the top of the upper barrier poles  
9 28 by a series of steel neckrail clamp brackets 34, such that the pair of neckrails 32 run in  
10 parallel along the head-end of each row 16, 18 of stalls 14 (Fig. 1). (As used herein the term  
11 "head-end" refers to the part of the stall nearest to the centre line 22, as opposed to the "open  
12 end" into which the animal enters a stall.)

13 Connecting the upper barrier pole 28 and lower barrier pole 30 of each stall divider or barrier  
14 assembly is a generally C-shaped barrier component 36, with the barrier assembly comprising a  
15 connected pair of poles 28, 30 and the component 36. It can be seen that the ends of the "C"  
16 shape are mated with the poles 28, 30 at the open end of the stalls. The poles are either hollow  
17 along their length or hollow at the end section to receive an end section of the component 36,  
18 which will now be described in greater detail.

19 Referring to Fig. 3-8, the barrier component 36 is shown in perspective (Fig. 3), from the front,  
20 rear, below and one side (Figs. 4, 6, 7 and 8, respectively), and in Fig. 5 in cross section taken  
21 along the line V-V in Fig. 4.

22 The component 36 comprises a curved, elongated body member made of vulcanised, moulded  
23 rubber (though other flexible elastomers can be used). The body member has a middle section  
24 38 which is curved into an arc and which occupies the major part of the length of the generally  
25 cylindrical curved body 36. The arc subtends an angle of 165 degrees, such that its upper end  
26 40 is offset from its lower end 42 by an angle of 15 degrees, as seen in Fig. 8, matching the  
27 offset of the poles 28, 30.

28 Each of the end sections ends 40, 42 is provided with a through hole 44 allowing it to be  
29 secured in place within its respective pole 28, 30 using a bolt (not shown) which passes through  
30 a corresponding pair of holes (not shown) in the pole. The diameter of the end sections 40, 42 is  
31 dimensioned to make a snug fit with the interior diameter of the hollow ends of the poles. The  
32 diameter of the middle section is approximately the same as the outside diameter of the poles.

1 Between the middle section 38 (having a first diameter) and the each of the ends 40, 42 (having  
2 a second diameter less than the first diameter), is a collar formation 46 which has a flared  
3 formation 48 (Fig. 5) that increases in diameter towards the end section to which it is adjacent  
4 from the first diameter where it merges with the middle section to a third diameter greater than  
5 the first and second diameters. An annular skirt 50 projects axially from the flared formation 48  
6 towards the end section 40,42 to which the collar is adjacent. The skirt 50 and the end section  
7 40, 42 define between them an annular recess 52 which is dimensioned to receive the end of  
8 the pipe or pole 28,30 onto which the component is mounted.

9 When the component 36 is mounted on a pair of poles 28, 30, the collar shields the pole ends  
10 and provides a continuous rather than abrupt transition. The resulting assembly is flexible and  
11 designed to avoid injuring the animals, while overcoming the disadvantages of known prior art  
12 systems as described earlier.

13 The invention is not limited to the embodiments described which can be modified without  
14 departing from the scope of the claimed invention.

**WE CLAIM:**

1. A barrier component for an animal stall, comprising:
  - a curved, elongated body member of elastomeric material, the body having first and second end sections;
  - the first end and the second end sections each being adapted for engagement within a hollow pipe; and
  - a collar formation adjacent the first end or the second end which defines an annular recess for receiving a hollow pipe end.
2. The barrier component of claim 1, wherein said curved, elongated body subtends an angle of between 90 and 220 degrees, more preferably between 140 and 180 degrees, even more preferably between 150 and 175 degrees.
3. The barrier component of claim 1 or 2, wherein said body is generally cylindrical along its length and has a first diameter in a middle section thereof, the first and second ends having a second diameter which is less than the first diameter.
4. The barrier component of any one of claims 1 to 3, wherein the collar comprises a flared formation which increases in diameter towards the end section to which it is adjacent.
5. The barrier component of claim 4, when dependent on claim 3, wherein the flared formation increases in diameter from the first diameter where it merges with the middle section to a third diameter greater than the first diameter, the increase in diameter being continuous rather than abrupt.
6. The barrier component of claim 4 or 5, wherein the collar further comprises an annular skirt projecting axially from the flared formation towards the end section to which the collar is adjacent, the skirt and the end section defining between them said annular recess.
7. The barrier component of any of claims 4 to 6, wherein two of said collars are provided, one adjacent each end section.
8. The barrier component of any one of claims 1 to 7, wherein the end sections are provided with a through hole to receive a locking member.

9. The barrier component of any one of claims 1 to 8, wherein the elastomeric material is vulcanised moulded rubber.
10. A barrier assembly for an animal stall comprising the barrier component of any one of claims 1 to 9, and first and second pipes each having a hollow free end, wherein the free ends of the first and second pipes receive a respective one of the first and second ends of the barrier component, such that the curved elongated body member connects the first and second pipes.
11. An animal stall assembly comprising a plurality of barrier assemblies according to claim 10 mounted parallel to one another along a central barrier such that the barrier assemblies are spaced apart from one another and each adjacent pair of barrier assemblies defines a respective animal stall, the first and second pipes of each barrier assembly being generally mounted one above the other and the barrier component of each barrier assembly being disposed at an outer end of the stall away from the central barrier.
12. A stall divider for animal stalls, comprising:  
  
first and second pipes each having a head end adapted for mounting on a fixed head-end barrier, whereby in use said pipes extend from said head end to a free end, the pipes lying within and defining a substantially vertical plane which separates a pair of neighbouring stalls; and  
  
the barrier component of claim 1 mounted in the free ends of the first and second pipes, respectively.
13. The stall divider of claim 12, wherein said first and second pipes are made of polypropylene random copolymer.
14. The stall divider of claim 12 or claim 13, wherein said barrier component comprises a solid flexible tube extending in a curved fashion from the free end of the first pipe to the free end of the second pipe.
15. The stall divider of any one of claims 12 to 14 wherein said barrier component is secured to the free ends by being inserted into a hollow terminal portion at the free end of each pipe, and being secured by a bolt extending through the free end and the connecting member.

1/4

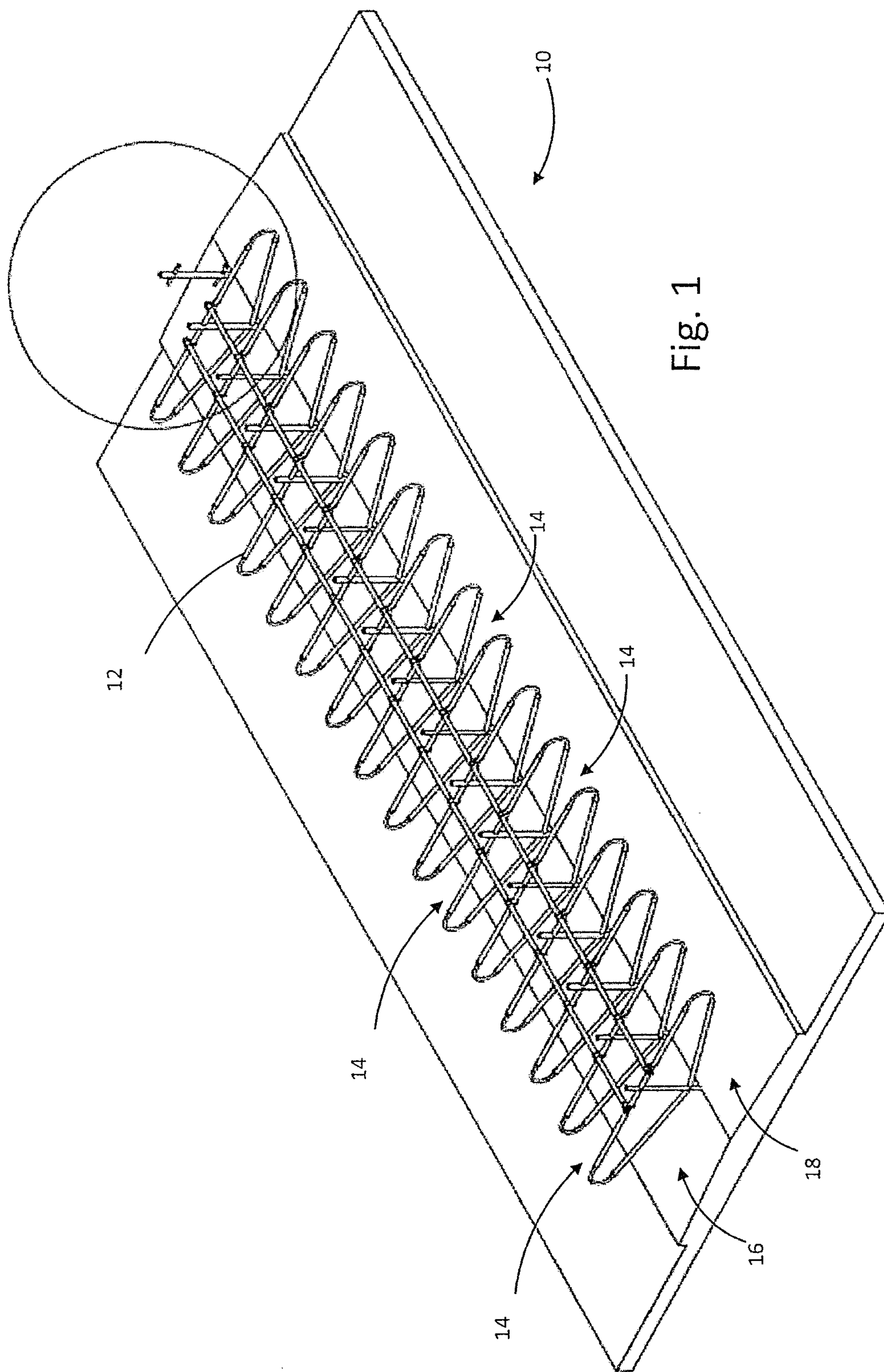

Fig. 1

2/4

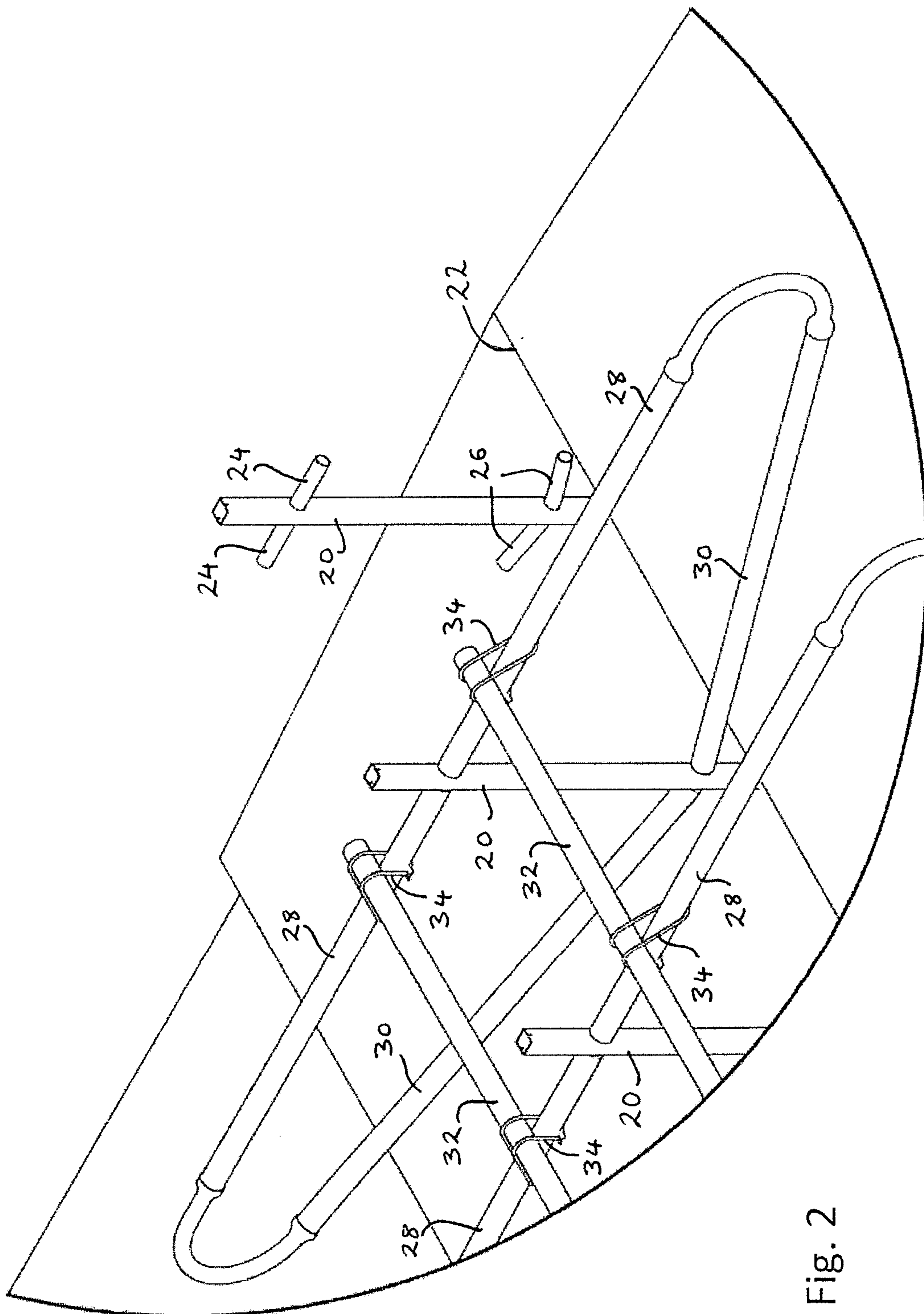

Fig. 2

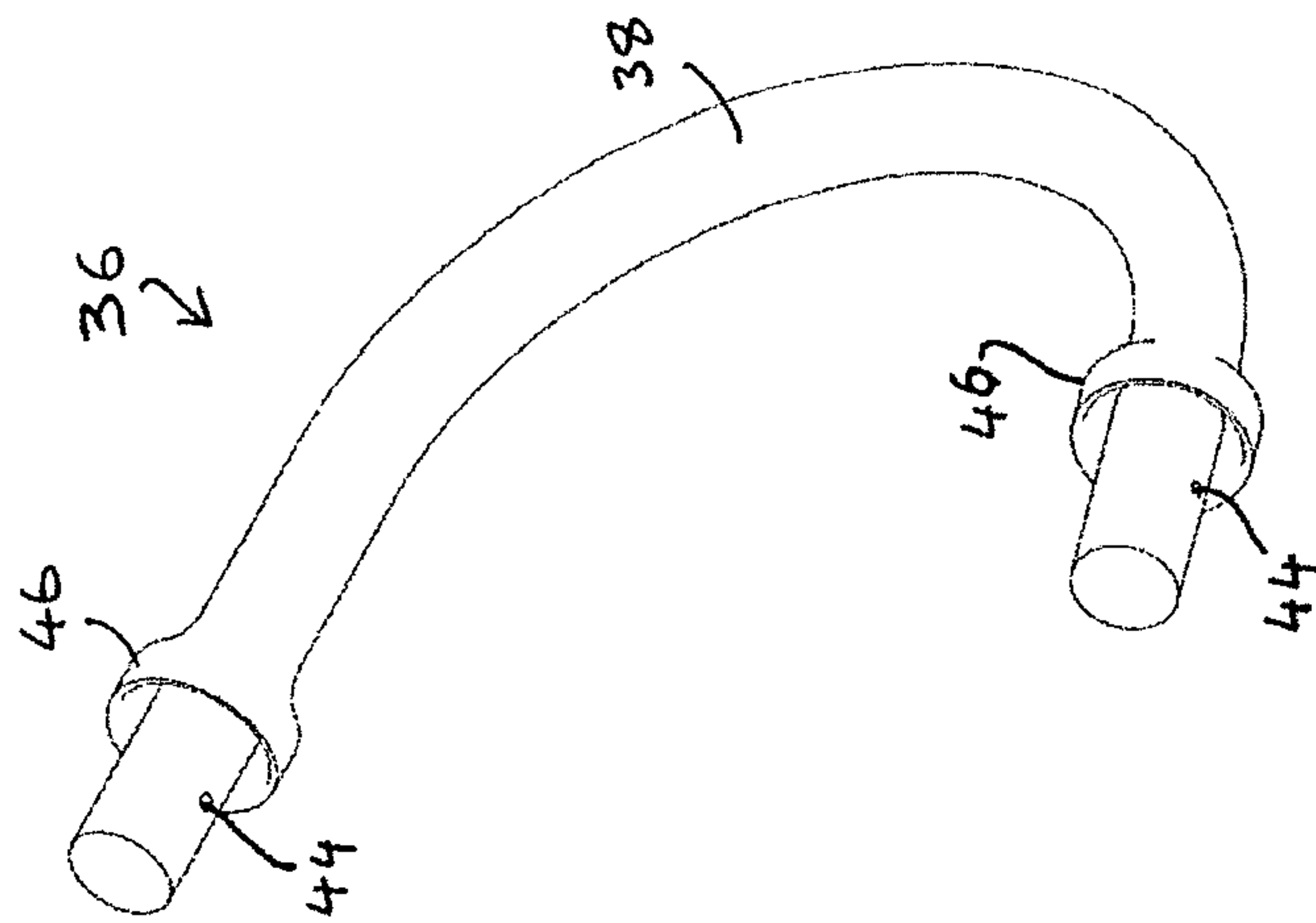

Fig. 3

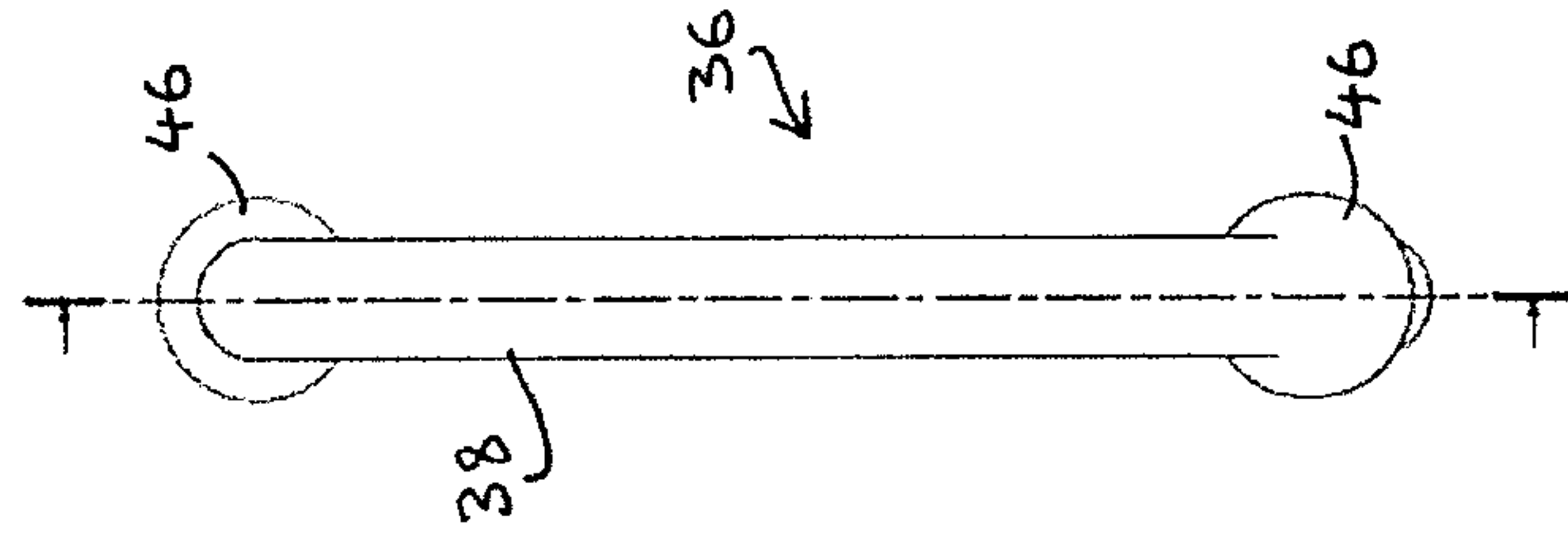

Fig. 4

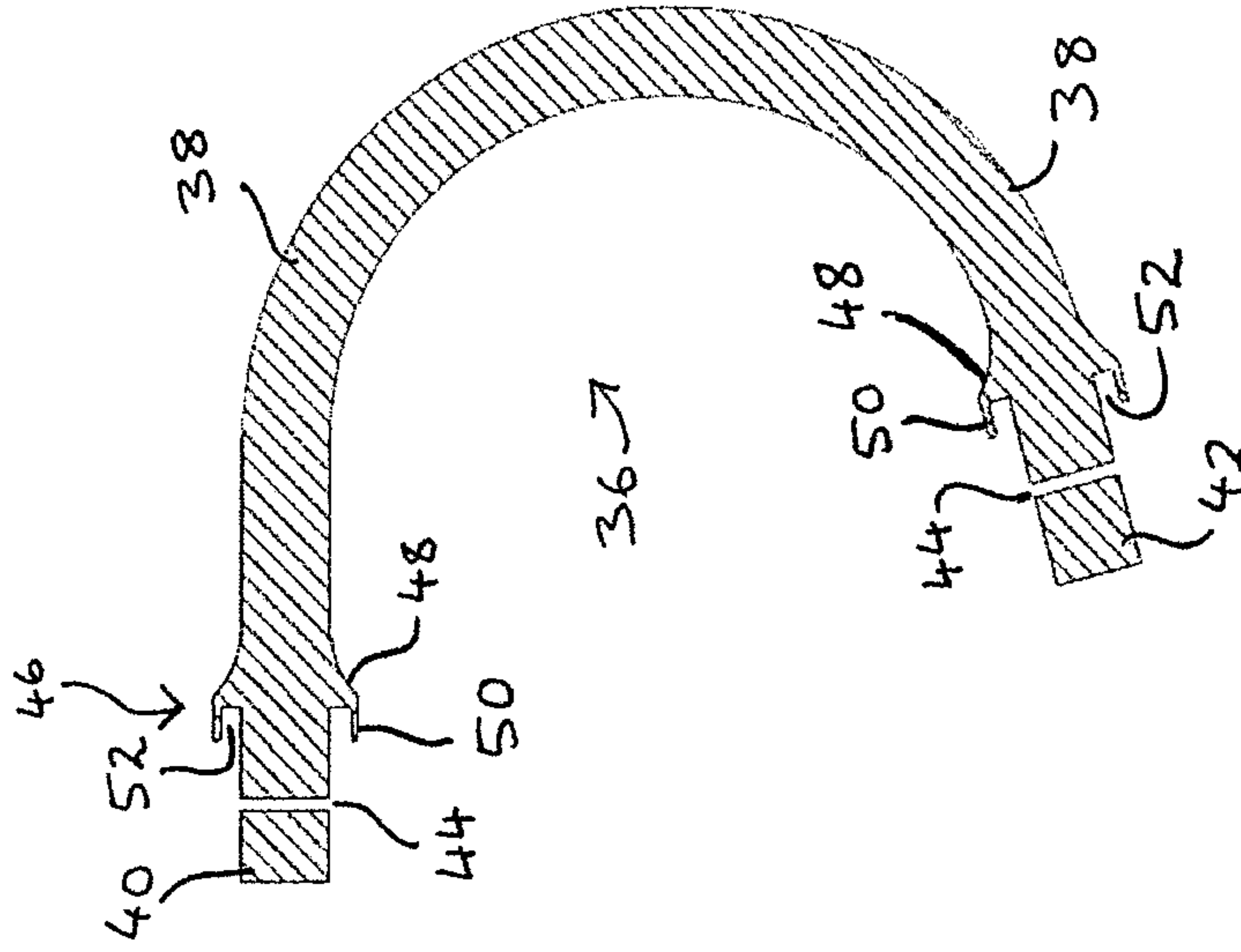

Fig. 5

3/4

Fig. 6

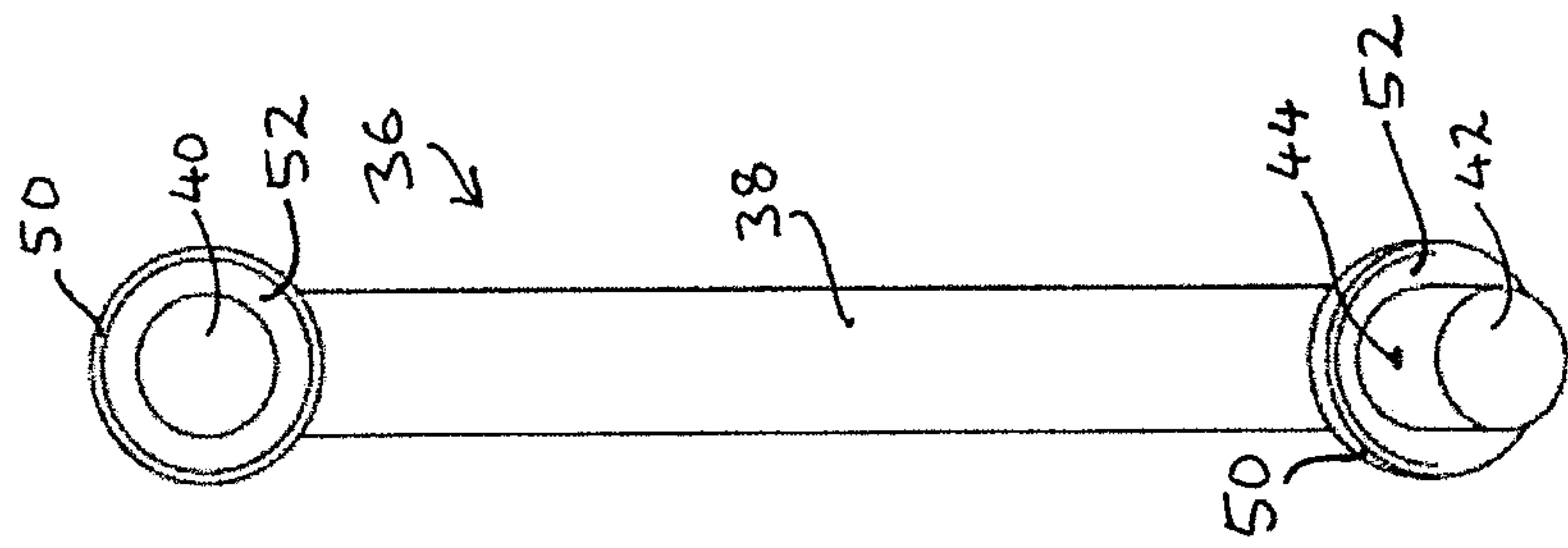

Fig. 7

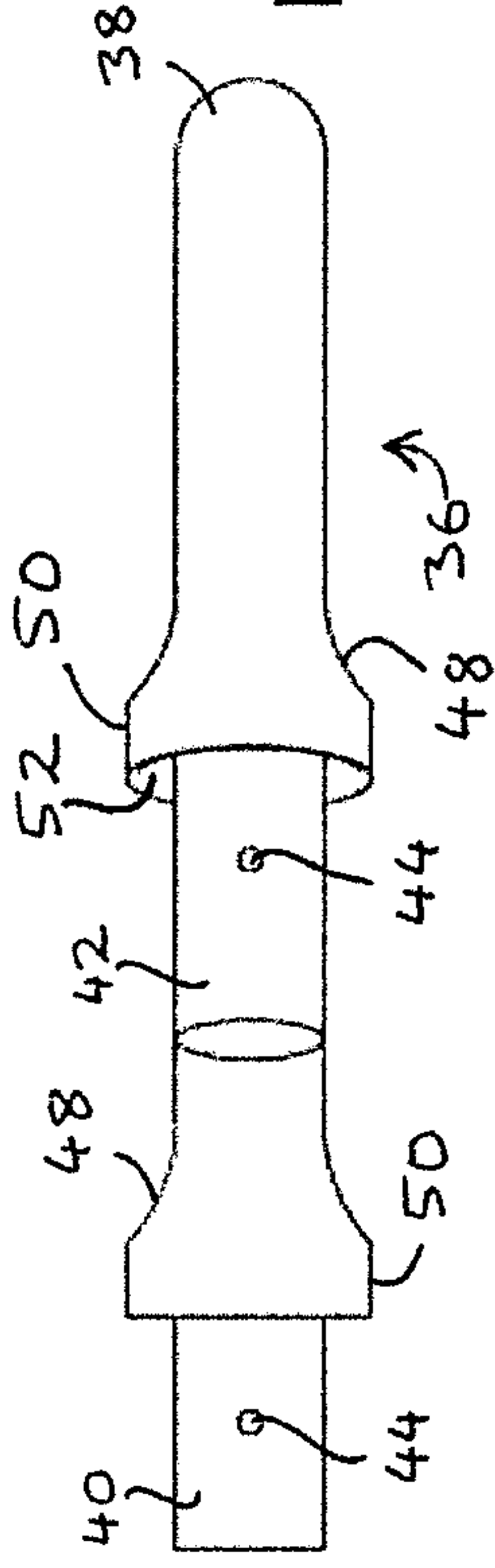

Fig. 8

