



(19) **United States**

(12) **Patent Application Publication**
FARBER

(10) **Pub. No.: US 2002/0005657 A1**

(43) **Pub. Date: Jan. 17, 2002**

(54) **MOTOR VEHICLE ROOF**

Publication Classification

(76) Inventor: **MANFRED FARBER, WIELENBACH**
(DE)

(51) **Int. Cl.⁷ B60J 7/00**

(52) **U.S. Cl. 296/219**

Correspondence Address:

DAVID S SAFRAN ESQ
SIXBEY FRIEDMAN LEEDOM &
FERGUSON PC
8180 GREENSBORO DRIVE
SUITE 800
MCLEAN, VA 22102

(57) **ABSTRACT**

(*) Notice: This is a publication of a continued prosecution application (CPA) filed under 37 CFR 1.53(d).

The invention relates to a motor vehicle roof with a series of cover elements (louvers **10a-d**) for selectively closing and at least partially exposing a roof opening (**13**) in a fixed roof surface (**11**), the cover elements bordering one another in the closed position to form a flat panel system, each louver on its narrow end being connected to a pivoting fastening element (**20a-d**) which is guided along a roof-mounted guideway (**75**). The flat panel system is pushed together by pushing on the front and/or the back end to form a bundle of swung-out cover elements and it can also be moved as a bundle. At least some of all fully swung-out fastening elements (**20a-d**) are securely engaged to a common coupling element which can move along the roof-mounted guideway or can be fixed relative to it.

(21) Appl. No.: **09/368,905**

(22) Filed: **Aug. 6, 1999**

(30) **Foreign Application Priority Data**

Aug. 6, 1998 (DE)..... 198 35 535.1

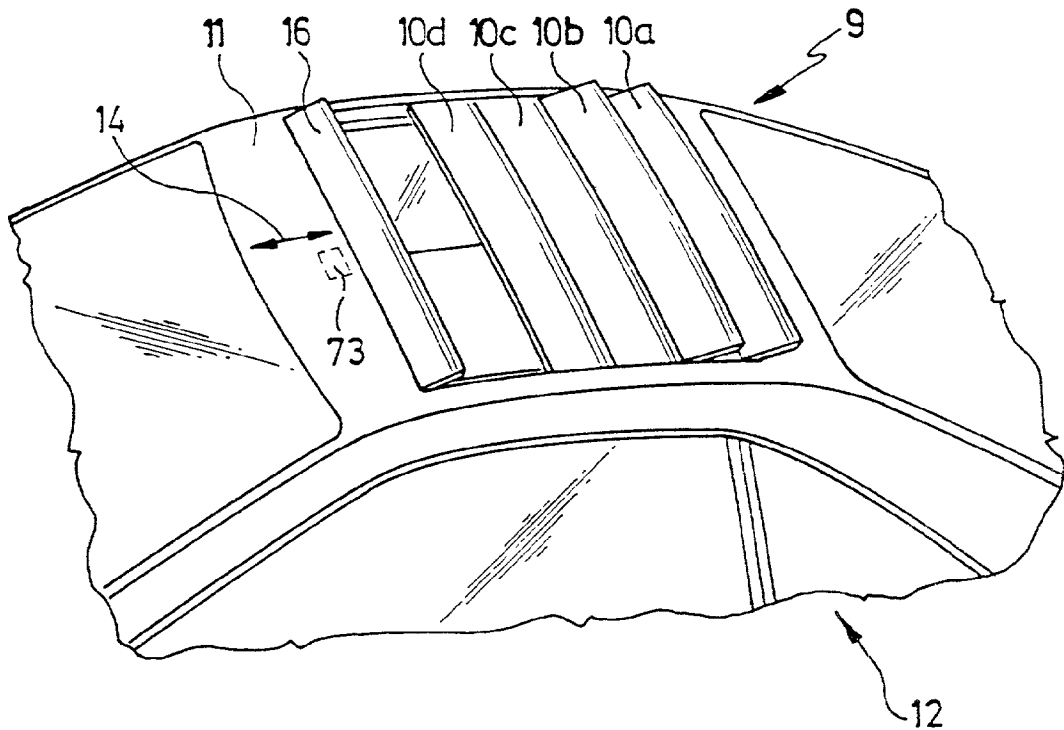

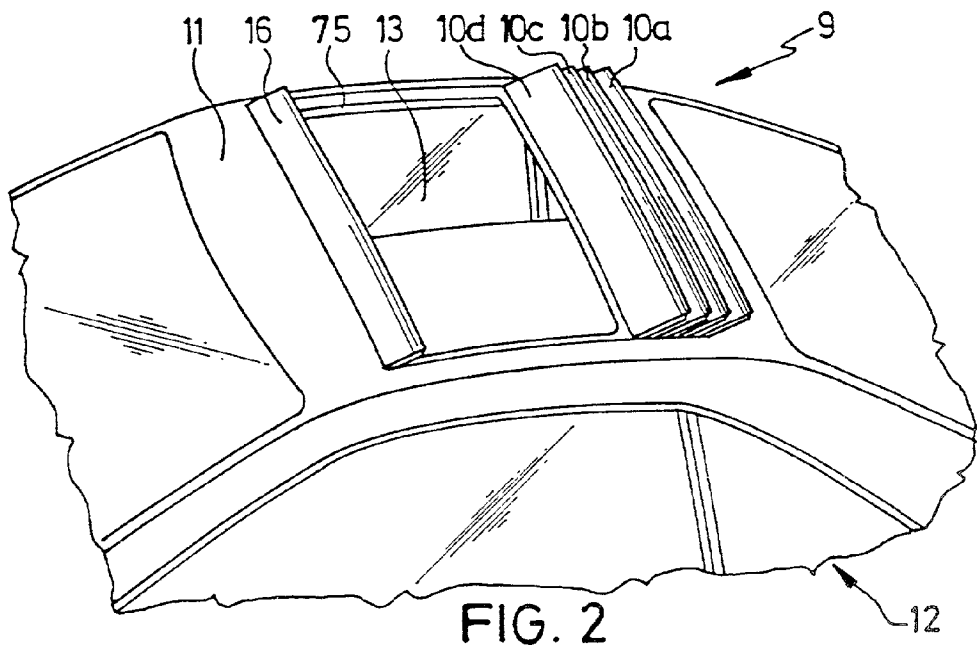
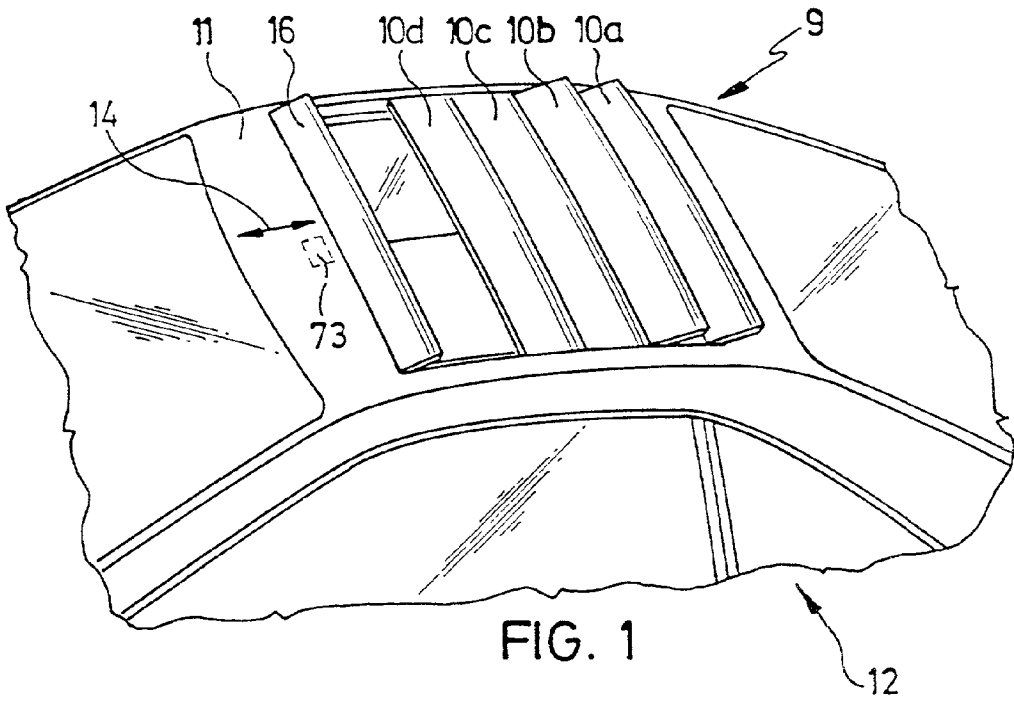

FIG. 3

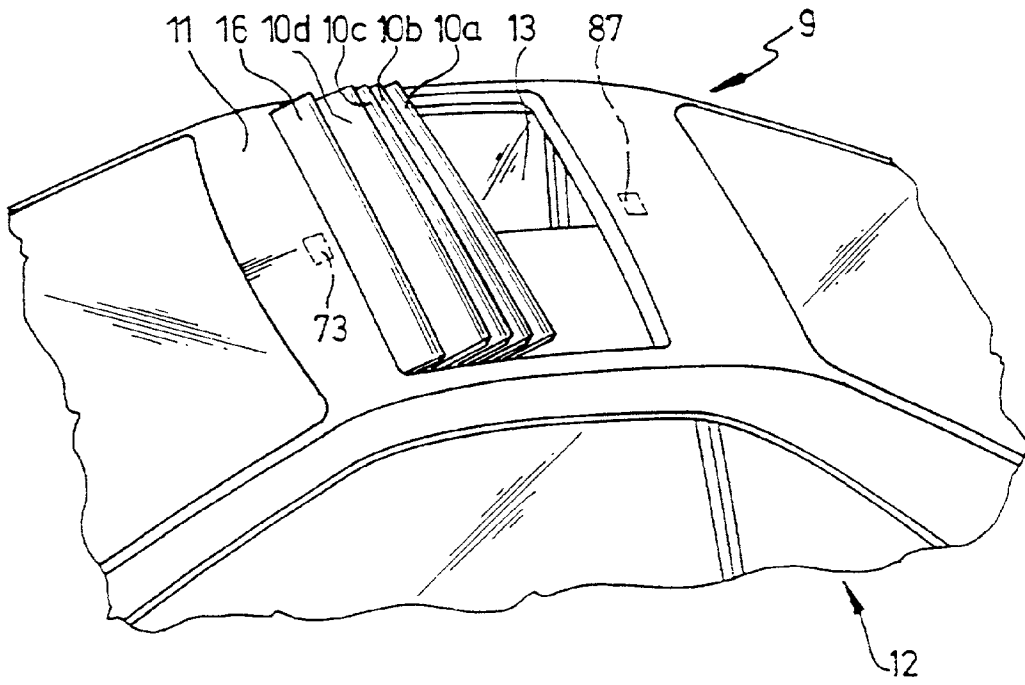
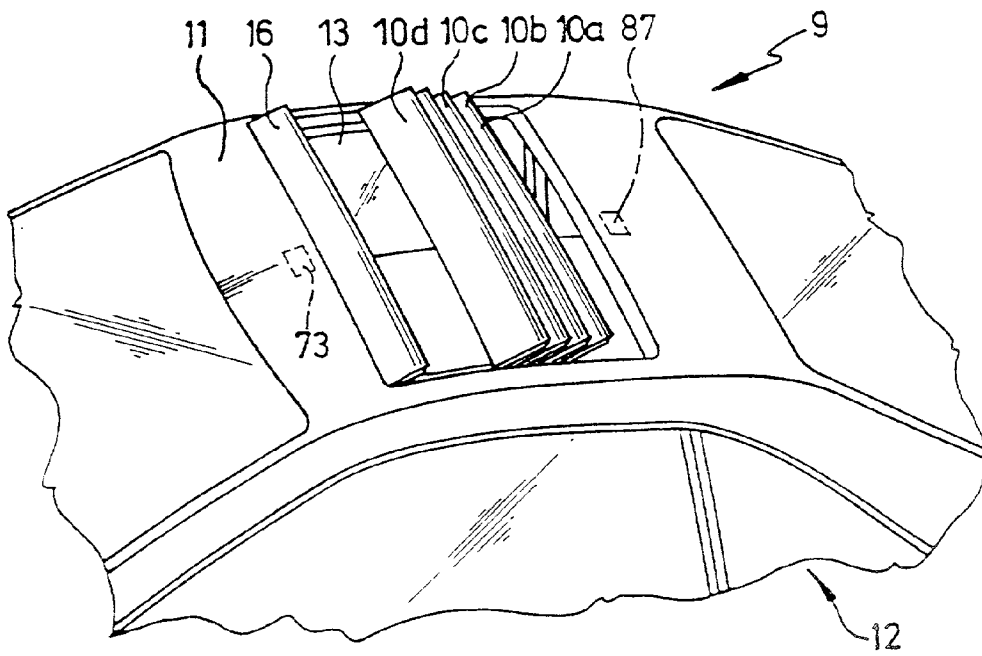

FIG. 4



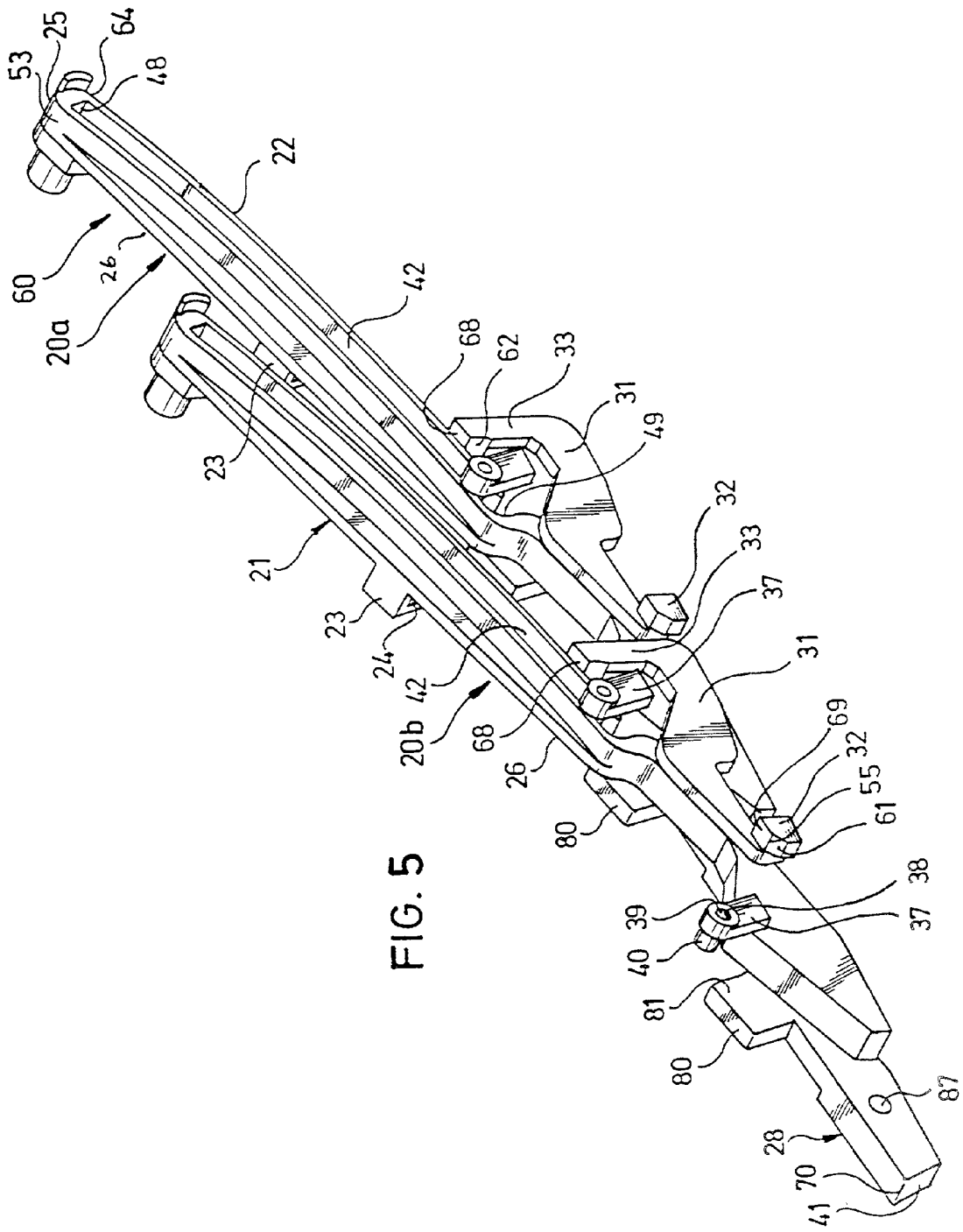

FIG. 5

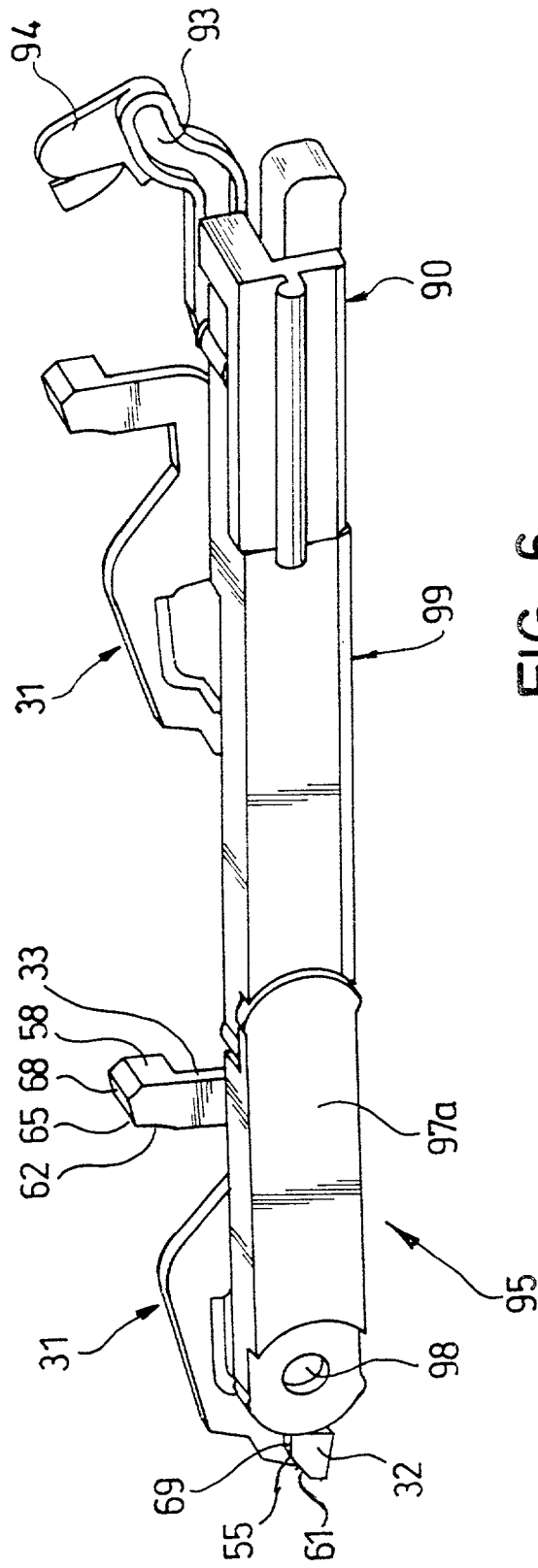

FIG. 6

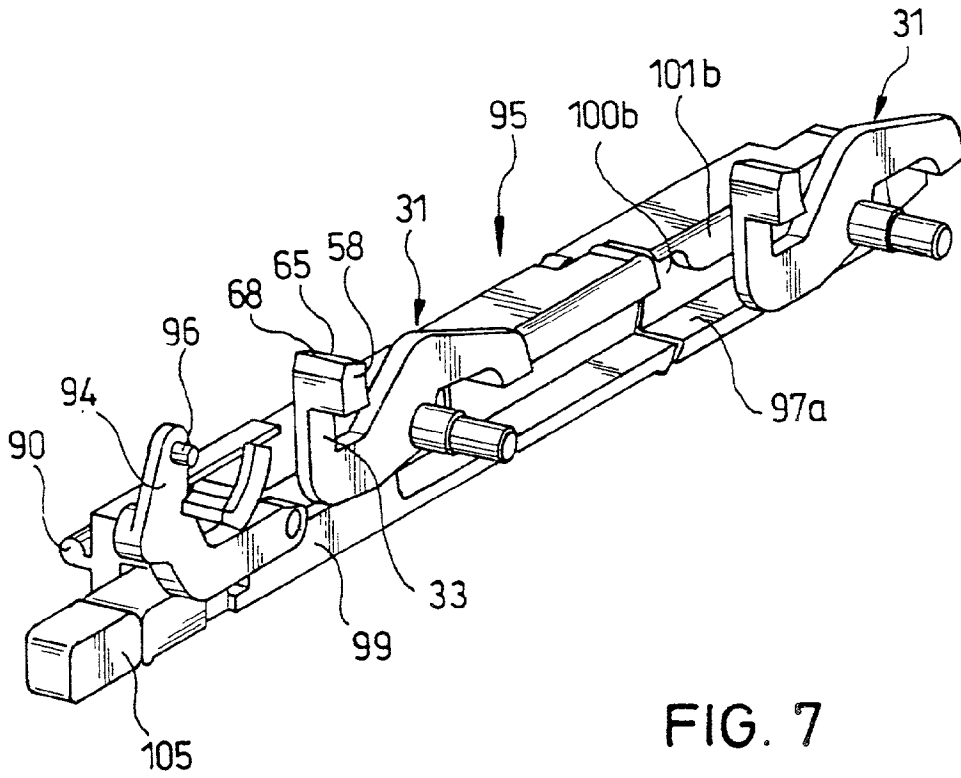

FIG. 7

FIG. 10

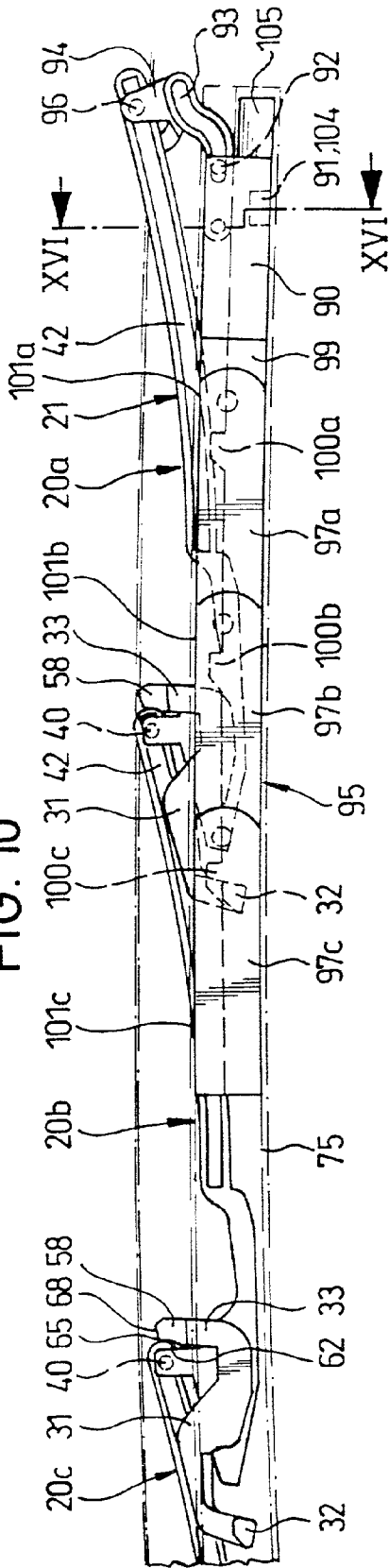

FIG. 11

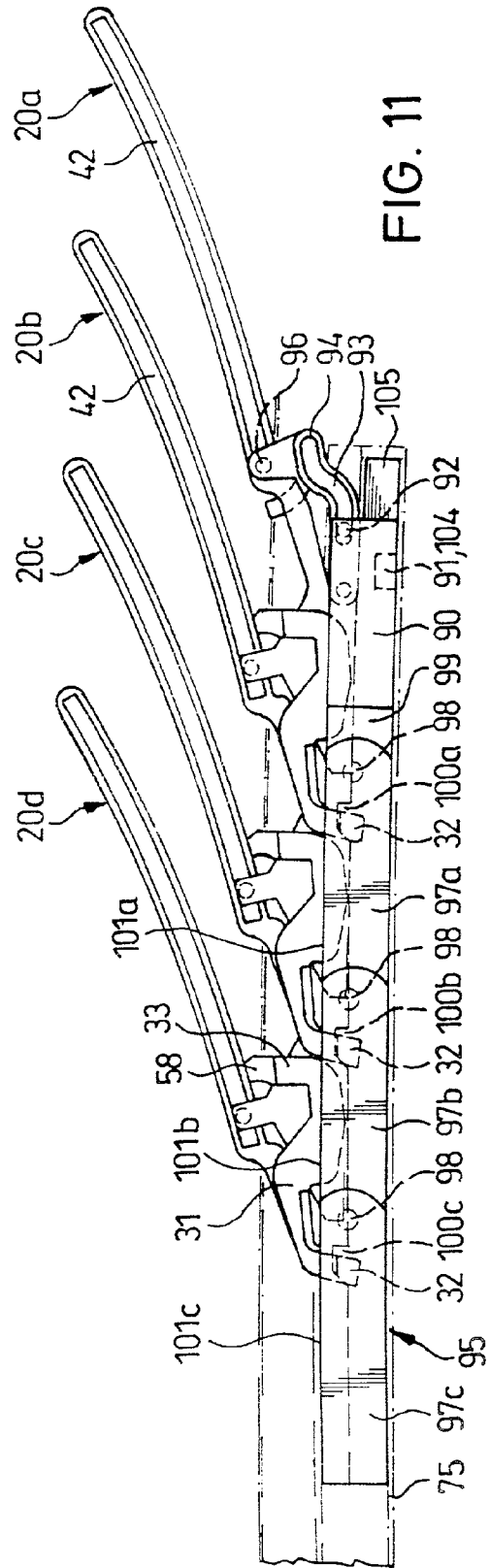

FIG. 12

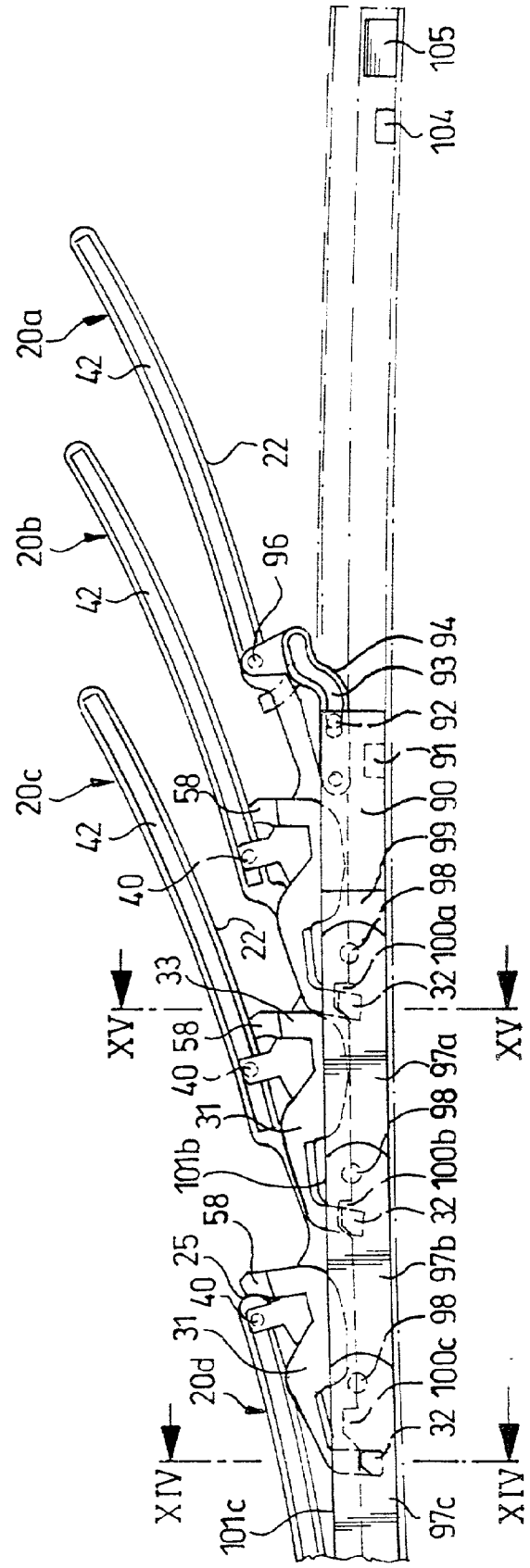

FIG. 13

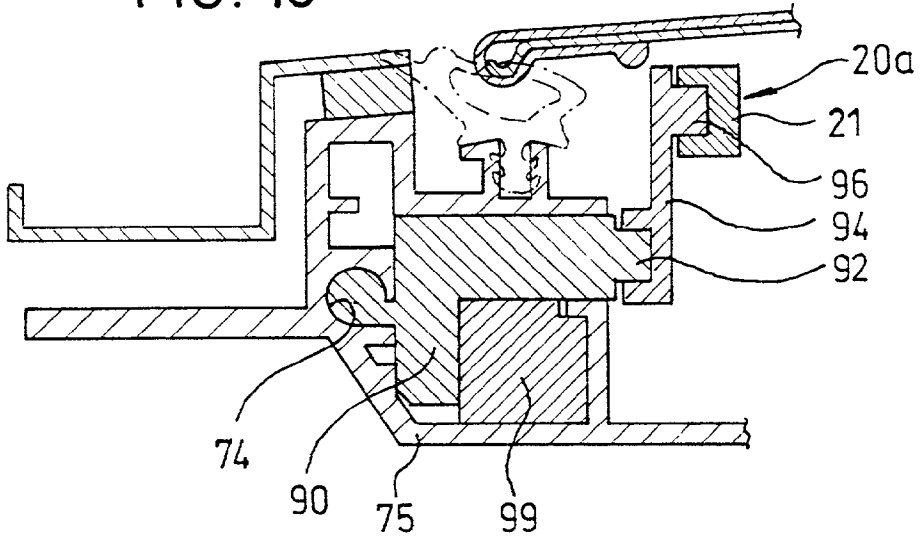

FIG. 14

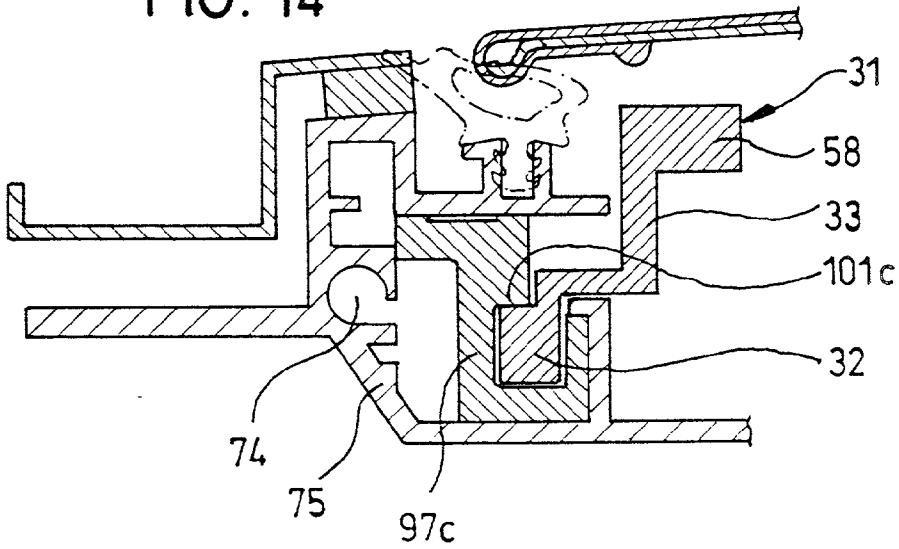

FIG. 15

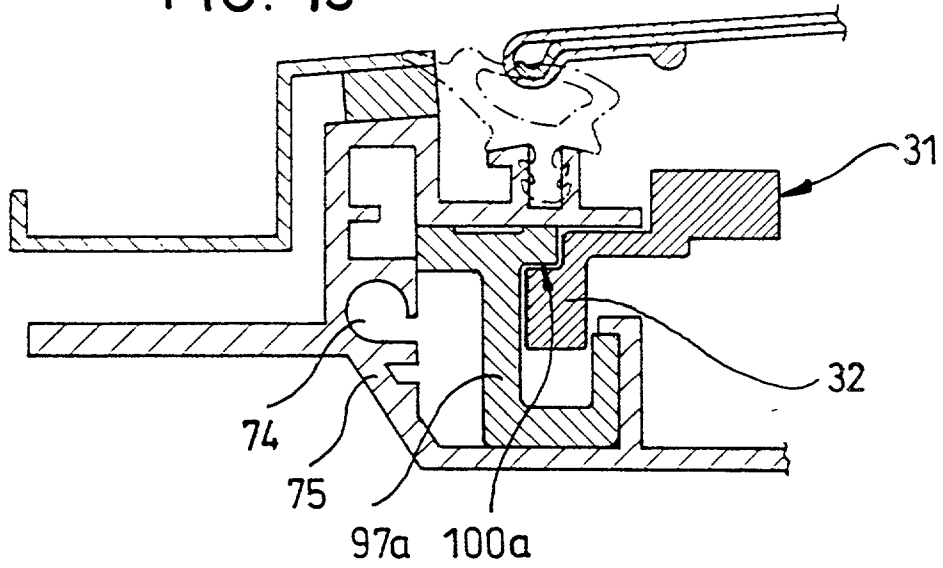
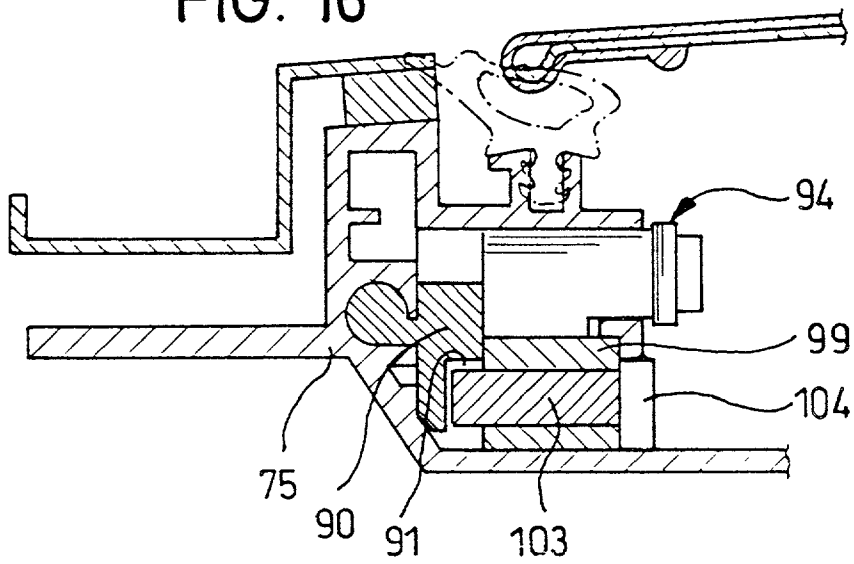

FIG. 16



MOTOR VEHICLE ROOF

BACKGROUND OF THE INVENTION

[0001] 1. Field of the Invention

[0002] The invention relates to a motor vehicle roof for selectively closing or at least partially exposing a roof opening in a fixed roof surface which has cover elements which border one another in a closed position to form a flat panel system, each louver being connected on a narrow edge thereof to a pivotable fastening element which is guided along a roof-mounted guideway for movement between a position in which the respective cover element is in the closed position and a position in which the respective cover element is fully swung out, two adjacent fastening elements being coupled for common motion in opening and closing directions until a first of the two fastening elements has reached the position in which the respective cover element is fully swung out, at which point the two adjacent fastening elements are decoupled enabling relative displacement of the second of the two adjacent fastening elements against the first as the second moves into the position in which the respective cover element connected thereto is fully swung out, and under the influence of motion of the second of the two adjacent fastening elements in the opening direction, the first fastening element is locked with a fastening element of a cover element already in the fully swung out position thereof, the locking being automatically released under the influence of motion of the second of the two adjacent fastening elements in the closing direction.

[0003] 2. Description of Related Art

[0004] A generic motor vehicle roof of the type to which the invention is directed is known from German Patent Nos. DE 195 29 522 C1 and DE 195 29 702 C1. They describe a locking mechanism with a swivelling bolt block which securely interlocks adjacent fastening elements to one another under the direct influence of the opening motion of the fastening element which precedes these two fastening elements, i.e., without using a bolt block slide, as soon as these two fastening elements are swung fully out, or which unlocks them again under the influence of the corresponding closing motion. The disadvantage in this locking mechanism is that, in case of an accident, all the acceleration of the louver bundle must be accommodated by the locking between the last two fastening elements; this leads to failure of locking.

[0005] U.S. Pat. No. 5,897,160 discloses a similar motor vehicle roof in which the swung-out attachment elements are not locked among one another, but are each locked individually securely to the roof-mounted guideway. The locking elements are formed by bolt rockers which are pivotally supported in their middle section, and have on a bolt part on one end section and an actuating arm on their other end section. The bolt part fits into corresponding recesses in the roof-mounted guideway in the locking position.

[0006] The disadvantage is that, in this motor vehicle roof, the roof opening can only be opened from front to back, i.e., for example, the back part of the roof opening cannot be opened independently of the front part.

SUMMARY OF THE INVENTION

[0007] The primary object of this invention is to devise a motor vehicle roof with a series of cover elements, which

has an automatically releasable locking mechanism which enables flexible opening and closing of the motor vehicle roof and also guarantees reliable locking in case of an accident.

[0008] This object is achieved as claimed in the invention proceeding from a motor vehicle roof of the initially mentioned type by at least some of all fully swiveled-out fastening elements being securely engaged to a common coupling element which can move along the roof-mounted guideway and which can be fixed relative to it.

[0009] In this approach of the invention, it is advantageous that the roof opening can be opened from the front and from the rear, and the locking mechanism of each individual fastening element is subjected only to a relatively small inertial force even in an accident.

[0010] In one advantageous embodiment of the invention, it is provided that the coupling element can be locked in at least one position to a roof-mounted guideway, preferably there furthermore being a coupling control part which can be driven along the guideway by a drive and which can be locked to the coupling element. This leads to safety in accidents.

[0011] In one advantageous development of the invention, the coupling element has a locking device for locking to the roof-mounted guideway or to the coupling control part, which is actuated by displacement of the coupling control part with respect to the coupling element in the closed position of the cover element combination, such that it releases the locking to the roof-mounted guideway and closes the locking to the coupling control part. When opening from front to back, this allows reliable fixing of the cover element bundle in the rear part of the roof opening, while opening is also possible from back to front selectively without additional driver interventions.

[0012] Preferably, the coupling control part is engaged to the rearmost fastening element such that displacement of the coupling control part along the roof-mounted guideway causes the rearmost fastening element to swing out or swing back. This makes actuation of the rearmost fastening element by a drive located forward unnecessary, so that a force transfer means from the front end of the roof opening to its back end is not needed.

[0013] It is also preferred that the coupling element furthermore comprises several members which are joined to one another with a pivoting capacity. This allows matching of the coupling element to arched roof shapes.

[0014] It is possible for the locking between the fastening elements and the coupling element to take place via a locking element which is made as a bolt rocker which is mounted to pivot in its middle section. On one end section, the locking element has a bolt part and on its other end section it has an actuating arm, the coupling element for each fastening element having a bolt recess for holding the bolt part. This represents a simple, and at the same time, reliable embodiment.

[0015] These and further objects, features and advantages of the present invention will become apparent from the following description when taken in connection with the accompanying drawings which, for purposes of illustration only, show a single embodiment in accordance with the present invention.

BRIEF DESCRIPTION OF THE DRAWINGS

[0016] FIG. 1 is a schematic perspective view of a louvered roof in the partially opened state;

[0017] FIG. 2 is a view corresponding to FIG. 1 for a roof opening completely opened from the front;

[0018] FIG. 3 is a view corresponding to FIG. 1 for a roof opening completely opened from the back;

[0019] FIG. 4 is a view corresponding to FIG. 1 for a roof opening completely opened both from the front and the back;

[0020] FIG. 5 shows a perspective view of the adjustment elements of two fastening elements which have been swung out;

[0021] FIGS. 6 and 7 show perspective views opposite sides of a part of the coupling element with a coupling control part and two bolt rockers;

[0022] FIG. 8 is a side elevational view of one part of the fastening elements and of the coupling element with the coupling control part in the closed position;

[0023] FIG. 9 is a bottom plan view of the arrangement shown in FIG. 8;

[0024] FIG. 10 is a view like FIG. 8, but with the last louver raised above the rear edge of the roof opening;

[0025] FIG. 11 is a view like FIG. 8, but in the position of FIG. 2;

[0026] FIG. 12 is a view like FIG. 8, but in the position of FIG. 4;

[0027] FIG. 13 is a cross-sectional view taken along XIII-XIII in FIG. 8;

[0028] FIG. 14 is a cross-sectional view taken along XIV-XIV in FIG. 12;

[0029] FIG. 15 is a cross-sectional view taken along XV-XV in FIG. 12; and

[0030] FIG. 16 is a cross-sectional view taken along XVI-XVI in FIG. 10.

DETAILED DESCRIPTION OF THE INVENTION

[0031] In the following description, the terms “front,” “forward” or “preceding” mean in a direction away from the louver that is fully swung out first, “back,” “rear,” “rearward,” and “following” mean in the direction towards the louver that is fully swung out first, “inner” means transversely relative to the direction of travel of the louvers and towards the longitudinal centerline of the roof opening, “outer” means transversely relative to the direction of travel of the louvers and away from the longitudinal centerline of the roof opening, “top” and “upward” mean away from the floor of the motor vehicle, “bottom” and “downward” mean towards the floor of the motor vehicle. In regard to the illustrated embodiment, especially, “front,” “forward” or “preceding” mean in the normal direction of forward vehicle travel, and “back,” “rear,” “rearward,” and “following” mean opposite the normal direction of forward vehicle travel.

[0032] The term “louver” should not be understood restrictively with respect to geometrical shape, especially

with respect to the ratio of length to width. It is also intended to encompass roof elements which are, for example, as long as they are wide.

[0033] The motor vehicle roof 9 which is explained here and which can be called a louvered roof has, as follows from the schematics of FIGS. 1 & 2, a series of sliding louvers 10a to 10d. These louvers are used for selective closing or at least partial exposing of a roof opening 13 which is made in a fixed roof surface 11 of a motor vehicle 12. To open and close the roof 9, the louvers 10a to 10d can be displaced; in the embodiment shown, the displacement direction indicated with the double arrow 14 running parallel to the longitudinal axis of the motor vehicle. Basically, other displacement directions are also possible, for example, transversely to the longitudinal axis of the motor vehicle. In their closed position, the louvers 10a to 10d abut one another with their longitudinal edges which run transversely to the displacement direction 14 (or with the sealing elements located there) there to form a seal. In doing so, they form a flat panel system of louvers as is shown in FIG. 1 for the two louvers 10d and 10c. The louvers 10a to 10d can, furthermore, each be pivoted around a (virtual) pivot axis which extends transversely to the direction of displacement 14 and which, in the embodiment shown, lies roughly at the height of the fixed roof surface 11.

[0034] An displacement mechanism, which is explained in greater detail below, coordinates the sliding displacement and pivot motions of the individual louvers 10a to 10d such that, when the sliding louvers are displaced, the flat louver system executes translational motion in the displacement direction 14 and this system is dissolved one louver at a time as each louver moves out of the system when the roof 9 is opened in the area of the front and/or back end of the system, or and is re-established when the roof is closed. In addition to opening from the front and/or the back, the louver bundle in the opened state can also be moved with a variable bundle size to anywhere on the roof opening. In the course of opening of the roof 9 which had been closed before, first the louver 10a is pivoted such that its back edge disengages from the back edge of the roof opening 13 into an oblique position. Then, an adjustment force can be exerted on the louver system toward the rear and/or toward the front.

[0035] For example, the louver 10a beginning in the above described oblique position can be pushed to the back together with the other louvers 10a to 10d which remain in the flat panel system, i.e., not swung out. During this translational movement, the louver 10a is continuously pivoted upward as it moves into its rearward end position. After the louver 10a has reached its rearward end position, which is illustrated in FIGS. 1 & 2, the next louver 10b is raised. This play is repeated until, as shown in FIG. 2, all of the sliding louvers 10a to 10c have been raised and pushed back to into their open position. When the roof 9 is closed, in this case proceeding from the open position according to FIG. 2, first only the louver 10d is moved forward and swung back into a position parallel to the fixed roof surface 11. A corresponding motion sequence is induced in succession for the following louvers 10c, 10b, and 10a until the louvers re-form the flat panel system in their front end positions closing the roof opening 13.

[0036] However, it is also possible, after initial swinging out of the louver 10a, to exert an displacement force on the

louver system from the back, and thus, to raise the louvers in succession beginning with the louver **10a** and to push them together in the direction toward the front edge of the roof opening **13**, as shown in **FIG. 3**.

[0037] Another alternative consists in that an adjustment force is applied to the louver system from the front and from the back so that, as shown in **FIG. 4**, in the opened state, a bundle of raised louvers **10a** to **10d** which has been pushed together is in the middle part of the longitudinal dimension of the roof opening **13**, and as a bundle with variable size, can also be moved anywhere on the roof opening.

[0038] In the case of the illustrated embodiment, in the area of the front end of the roof opening **13**, there sits a raisable, louver-shaped wind deflector **16** which, when the opening process is initiated, is pivot around an axis which runs transversely to the longitudinal axis of the motor vehicle into a position which rises obliquely toward the rear. In doing so, the roof assumes a ventilation position which can be used also in rain with the louvers in the closed position. The rear edge of the wind deflector **16**, in the closed position of the roof **9**, fits against the front edge of the forward-most sliding louver **10d** to form a seal, and thus, the wind deflector **16** closes the frontmost part of the roof opening **13**. Optionally, the layout can also be such that, in the closed position of louvers **10a** to **10d**, the flat panel system extends from the front edge to the back edge of the roof opening **13**, and thus, it alone assumes the closing function. In doing so, for sliding roofs, there can be a wind deflector which, in a conventional manner, disappears under the fixed roof surface with the roof closed, and which automatically raises into a working position when the roof is opened. **FIGS. 1 and 2** show a motor vehicle roof with four sliding louvers **10a** to **10d**; however, it goes without saying that the number of sliding louvers is essentially discretionary depending on the given circumstances. The entire roof opening **13** can be covered, for example, by only two louvers or cover elements.

[0039] Each of the louvers **10a** to **10d** is connected at its narrow side edges to a respective fastening element **20a** to **20d**. The fastening elements **20a** to **20d** are preferably made in the manner known from U.S. Pat. No. 5,897,160 which is hereby incorporated by reference and description of the details thereof omitted. Each of the fastening elements **20a** to **20d** is composed of an outer adjustment element **60** and an inner carrier element which bears a louver **10** (not shown). The adjustment elements **60** each have a rear part **21** and a front part **28**.

[0040] On the back end **53** of the rear part **21**, a curved contact surface **25** is provided which points toward the rear and by an edge **64** which extends toward the bottom **22** of the rear part **21**. The bottom **22** of the rear part **21** is formed by a surface which is slightly curved in the displacement direction **14**. In the back area at the outer side of the rear part **21** of the adjustment element **60** is a curved crank slot **42** with a curvature which runs roughly parallel to the curvature of the bottom **22**, and has a front end **49** and a back end **48**.

[0041] The rear part **21** has an inner side **26** of the adjustment element **60** has a laterally extending driver **23** in approximately the middle thereof. Driver **23** is formed with a contact surface which faces rearward and which is bor-

dered by a lower edge and is slightly curved toward the front. The driver **23** also has a recess **24** which is open from below.

[0042] Each of the attachment elements **20a**, **20b**, etc. is movably guided in the conventional manner in a roof-mounted guideway which is formed in the guide rail **75**.

[0043] Farther forward, on the laterally outer side of the adjustment element **60**, an arm **37** which extends upward and is provided with a hole **38**. A pin **39** fits into this hole **38** and carries a guide shoe **40**. The shoe **40** is connected to the arm **37** on its inner side with a capacity to pivot around an axis which is oriented transversely relative to the displacement direction **14**. The shoe **40** engages the crank slot **42** of the preceding fastening element **20b**, **20c**, etc. such that it can be displaced along the crank slot **42**.

[0044] The front end of the front part **28** is formed by a front face **41** with a top edge **70**. On the outer edge of the back section of the front part **28**, a hold-down **80** is formed which extends upward and has a contact surface **81** which faces toward the outside. The rear part **21** of the preceding adjustment element **60** which is connected to the following fastening element by engagement of the shoe **40** in the crank slot **42** is guided laterally at its inner side by the inner surface **26** of the rear part **21** of the adjustment element **60** making contact with the contact surface **81** of the hold-down **80** and laterally to the outside by contact with the shoe **40** or the arm **37**, so that no jamming can occur.

[0045] The front part **28** is offset parallel to the inside relative to the rear part **21** of the adjustment element **60**. The inside surface of the driver **23** which faces to the inside is roughly flush with the inner surface of the front part **28**. The recess **24** on the driver **23** is dimensioned such that the hold-down **80** of the following adjustment element **60** can move through this recess in the opening direction without the danger of jamming.

[0046] On the outer side of the front section of the rear part **21**, a locking element which is made as a bolt rocker **31** is pivotally mounted. The back section of the bolt rocker **31** is made as an actuating arm **33** which points upward and which has a curved contact surface **62** which points forward and up and which fits together with the contact surface **25** of the rear part **21** of the preceding adjustment element **60**. The contact surface **62** is separated from a top contact surface **68** by an edge **65** (**FIG. 6**). In its top section, the actuation arm **33** has a projection **58** which points inward. A pivot bearing element (not shown), for example, a riveted eye, fits through a hole (not shown) in the rear part **21** and a hole (not shown) in the middle area of the bolt rocker **31** with the formation of a pivot axis which is oriented transversely to the displacement direction **14** and around which the bolt rocker **31** can pivot with respect to the adjustment element **60**. In the front section of the bolt rocker **31**, a bolt part **32** is provided which is offset toward the outside. The bolt part **32** has an inclined contact surface **61** which faces upward and forward and an upper inclined contact surface **69** which borders it in the area of of an edge **55**. The bolt rocker **31** is pre-tensioned by a spring (not shown) on the pivot bearing element such that the actuating arm **33** is pressed upward.

[0047] A coupling control part **90** (**FIGS. 6, 7 & 9-16**), which is driven by a back drive unit **87** (**FIGS. 3 & 4**) by means of a rigid drive cable, is guided in the area of the

rearmost fastening element **20a** to move along a guideway **74** of the guide rail **75** (FIGS. 13-16). The coupling control part **90** has a bolt recess **91** and a crank pin **92** which fits into a S-shaped crank slot **93** of a raising lever **94** (FIG. 8) which is coupled on one end to pivot on the rearmost member **99** of a coupling element **95** and on its other end bears a crank pin **96** which fits into the crank slot **42** of the rearmost fastening element **20a**. The coupling element **95** is divided into several members **97a** to **97c** which are each pivotally connected to one another via a joint **98**. Each member **97a** to **97c** has a cheek **101a** to **101c** in which a bolt recess **100a** to **100c** is formed. The rearmost member **99** has a bolt hammer **102** which can be pivoted to the side and which has a head **103** which can fit into a bolt recess **104** of the guide rail **75** or into the bolt recess **90**. The coupling element **95** is, as is shown for the member **97c** in FIG. 14, movably guided along the guide rail **75**.

[0048] A drive cable (not shown), which is made preferably as a threaded cable, is drive-coupled to the front part **28** of the adjustment element **60** of the frontmost louver **10d**. The drive cable extends to a front drive unit **73** which is only generally represent in broken lines in FIG. 1. The front drive unit **73**, like the back drive unit **87**, in the conventional manner, can have an electric motor and step-down gearing, a rack connected to the output of the step-down gearing engaging the corresponding drive cables.

[0049] The described louvered roof works as follows:

[0050] In the closed position of the roof, adjacent louvers **10a-10d** or fastening elements **20a-20d** are securely coupled to one another. For rearward displacement, the face **41** of one fastening element (for example **20c**) abutting the rearward facing contact surface of the driver **23** of the preceding fastening element (for example, **20d**). Coupling for displacement forward takes place by the shoe **40** of one fastening element (for example, **20c**) abutting the back end **48** of the crank slot **42** of the preceding fastening element (for example, **20d**) and/or by engagement of two other contact surfaces of two adjacent adjustment elements **60**. The individual louvers are thus protected against accidental displacement. The bolt rockers **31** are each pretensioned by the springs such that the contact surface **62** of the actuation arm **33** adjoins the contact surface **25** of the preceding adjustment element **60**, as shown in FIG. 12, for fastening elements **20c** and **20d**.

[0051] The carrier elements, and thus the louvers **10**, all lie parallel to the roof plane. The adjacent fastening elements **20a**, **20b**, etc. are, as described above, reliably guided on alternating sides in the displacement direction by the rear part **21** making contact with the shoe **40** or the arm **37** and the hold-down **80**.

[0052] The side of the head **103** of the bolt hammer **102** fits into the roof-mounted bolt recess **104** to lock the rearmost member **99**, and thus the entire coupling element **95**, securely on the roof, the bolt hammer **102** thus being held in the bolt recess **104** by the other side of the head **103** contacting a wall of the coupling control part **90**. The rearmost member **99** is additionally secured by a stop **105** on the guide rail **75** to the back.

[0053] The crank pin **96** of the raising lever **94** lies on the back end **48** of the crank slot **42** of the rearmost fastening element. The crank pin **92** of the coupling control part **90** lies in the area of the back end of the crank slot **93** of the raising lever **94**.

[0054] To open the roof from the front to the back, force is transferred from the front drive unit **73** to the drive cables **59** on either side of the roof opening **13** in the direction which toward the rear. First of all, the drive motion of the drive cable causes the wind deflector **16** to swing out in the manner known from, for example, from German Patent 43 29 580.

[0055] Subsequently, or at the same time, the back drive device **87** is activated to push the coupling control part **90** to the front with respect to the rearmost member of the coupling element **95**. In doing so, the crank pin **92** of the coupling control part **90** slides toward the front in the crank slot **93** of the raising lever **94**, as a result of the shape of the crank slot **93** of the raising lever **94**, the rear end is swung upward. In this way, the crank pin **96** is also raised; as a result of its engagement in the crank slot **42** of the rearmost fastening element **20a**, this in turn causes the rearmost louver **10a** to be raised, by which it is lifted at its back edge above the seal (not shown) on the back edge of the roof opening **13** (see FIGS. 6 and 10). This raising process ends when the coupling control part **90** has been pushed so far to the front that the crank pin **92** has reached the front end of the raising lever **94**. In this position, the back drive **87** is turned off by program control, the last member **99** of the coupling element **95** remaining locked on the roof. The coupling control part **90** is held in place by self-locking of the back drive **87**, by which the raising lever **94** is fixed in the swung-out position. The crank slot **93** is laid out horizontally in the front area to equalize the hysteresis of the drive **87**.

[0056] The motor vehicle roof can also be made such that the above described swung-out position of the last louver **10a** can also be reached independently of whether the wind deflector **16** is swung out beforehand or not, so that an additional ventilation position is formed.

[0057] Subsequently, force is applied by the front drive **73**, i.e., by the front drive cables, on the frontmost fastening element **20d**. The force is transferred by form-fit from the driver **23** to the face **41** of the respective fastening element **20b**, **20c**, etc. which follows at the time, by which all louvers **10a** to **10d** move rearward together.

[0058] The crank pin **96** of the raising lever **94** is guided to slide in the crank slot **42** of the last fastening element **20a**. Continued displacement of the fastening element **20a** to the rear relative to the crank pin **96** of the raising lever **94**, in addition to displacement, causes a further raising motion of the last louver **10a**.

[0059] The guide points of the fastening elements are selected such that raising the rear end of the adjustment element **60** causes lowering of the face **41** relative to the driver **23** of the preceding fastening element **20b**. The shoe **40**, and thus also the back end of the preceding fastening element **20b**, are likewise slightly raised. A corresponding choice of the rotary lever or positions of the fulcrums (guide pins or bearing axes) ensures that the rear edge of the next-to-last louver **10b** is raised above the front edge of the last louver **10a** by the following (last) louver **10a** swinging out, so that the successive louvers can be pushed on top of one another. The fastening elements **20a** to **20d** are therefore coupled in such a way that the swinging-out motion of the last fastening element **20a** causes a swinging-out motion of the preceding fastening elements **20b** to **20d** which lessens

dramatically and which propagates forward. The prestress via the springs causes the actuating arm **33** to track any relative motion between the adjustment elements **60** so that it always adjoins the contact surface **25** of the rear part **21**.

[0060] The fastening elements **20a**, **20b**, etc. are pushed to the rear with reference to the coupling element **95**. The prestress by the springs reliably prevents the bolt part **32**, during opening motion, from catching in a bolt recess **100** of the coupling element as it passes it, for example, due to vibration.

[0061] The bolt part **32** is arranged such that the relative height of the bolt part **32** essentially remains unchanged with respect to the cheek **101** of the coupling element **95** during the increasing raising motion of the adjustment element **60** in the course of the opening motion. However, rotary motion of the bolt part **32** takes place. The top contact surface **69** of the bolt part **32** increasingly adjoins the bottom contact surface of the cheek **101** of the coupling element **95**. Due to a corresponding sloped configuration of the top contact surface **69** of the bolt part **32**, this contact causes a certain rotation of the bolt rocker **31** clockwise, i.e. the actuating arm **33**, and thus the contact surface **62**, move up.

[0062] The curvature of the contact surface of the driver **23** or the face **41** of the front part **28** is chosen such that, beginning with a certain swinging-out motion of the adjustment element **60**, the bolt rocker **31** transfers the drive force from the preceding adjustment element **60** to the following adjustment element **60** by contact of the top contact surface **69** with the bottom of the cheek **101**. This is advantageous in that overlapping of the contact surface **27** of the driver **23** with the face **41** becomes less and less as swinging out increases, so that the pressure becomes greater and greater; this could lead to damage of the corresponding contact surfaces **27** and **41** and especially of the edges **67** and **70** which border these surfaces. The corresponding elements are dimensioned such that force application passes at the proper time to the bolt rocker **31** such that this damage is prevented in any case. In this way, the force-fit between the last two fastening elements **20a,b** is already taken up by the corresponding bolt rocker **31** when the top edge of the face **41** of the last fastening element **20a** has not yet dropped entirely under the bottom edge **67** of the contact surface **27** of the driver **23** of the next-to-last fastening element **20b**.

[0063] As soon as the edge **55** between the contact surfaces **61** and **69** of the bolt part **32** has reached the bolt recess **100a** of the rearmost member **99** of the coupling element **95**, the bolt part **32** can move up into the bolt recess **100a**; this in turn allows the contact surface **62** or the edge **65** of the bolt part to slide down on the sloped contact surface **25** of the adjustment element **60**. In this way, the force-fit between the last two fastening elements **20a** and **20b** is canceled. These fastening elements are now decoupled. The next-to-last fastening element **20b** can now move relative to the last one.

[0064] The bolt part **32** is kept engaged with the last bolt recess **101a** of the coupling element **95** by the contact of the top contact surface **68** of the actuating arm **33** with the bottom **22** of the rear part **21** of the adjustment element **60**, and in this way, causes rooftop locking of the last fastening element **20a**. The last louver **10a** is thus secured against motion forward and backward.

[0065] The further opening process takes place analogously to what has already been described, now instead of

the last fastening element **20a** the next to last fastening element **20b** being swiveled out by displacement relative to the shoe **40** of the last fastening element **20a**. The function of the crank pin **96** of the raising lever **94** is consequently assumed by the shoe **40** or the front part **28** of the last fastening element **20a** which is now locked securely on the roof. When the next-to-last fastening element **20b** has been fully swung out, the rear face **51** of the next-to-last fastening element **20b** makes contact with the front face **41** of the last fastening element **20a**.

[0066] The decoupling of the force of two fastening elements (for example **20b,c**) during opening motion causes the preceding fastening element (**20c**) to lock the fastening element (**20b**) which follows at the time on the roof by pressing down the actuation arm (**33**) into the bolt recess (**100b**).

[0067] The opening process can now be analogously continued until the frontmost fastening element **20d** is fully swung out and the roof opening **13** is thus exposed to the maximum degree. Except for the frontmost louver **10d**, all louvers are then individually locked in the fully-swung out position with the coupling element **95** which, for its part, is locked on the roof via the bolt hammer **102**.

[0068] The frontmost louver **10d** is locked in its position by the front drive **73** being made rigid and self-locking in the conventional manner via the drive cables.

[0069] At this point, if a closing motion is initiated, force is transferred in the forward direction from the drive unit **73** to the drive cables which engage the first louver **10d** on either side of the roof opening **13**. The unlocked first louver **10d** is moved towards the front in this way. The shoe **40** of the second fastening element **20c** slides in the crank slot **42** of the first fastening element **20d**. The first fastening element **20d** is again swung back to some extent by the closing motion to the front. Movement of the second fastening element **20c** in the closing direction cannot take place since its bolt part **32** is kept engaged to the bolt recess **100c** via the contact of the actuating arm **33** of the bolt rocker with the bottom **22** of the first fastening element **20d**.

[0070] As soon as the edge **65** of the actuating arm **33** has reached the back end of the bottom **22** of the rear part **21** of the fastening element **20d**, the actuating arm **33** can move upward so that it becomes possible for the contact surface **61** of the bolt part **32** to slide down on a facing contact surface of the bolt recess **100c**. Force is applied to the fastening element **20c** in doing so, as described above, by the shoe **40** of the fastening element **20c** adjoining the back end **48** of the crank slot **42** of the preceding fastening element **20d** or by two other contact surfaces adjoining two adjacent adjustment elements **60** at a time. The bolt part **32** thus moves out of the bolt recess, by which the rooftop locking of the fastening element **20c** is canceled. The adjacent fastening elements **20d** and **20c** now are coupled to one another for the closing motion. Furthermore, the second fastening element **20c** is moved forward by the first **20d** at the same time. First of all, the two fastening elements **20c** and **20d** are coupled in the opening direction via the bolt rocker **31** of the second fastening element **20c**, later via the contact surface **27** of the driver **23** of the first fastening element **20d** and the face **41** of the second fastening element **20c**. This coupling in the opening direction would take effect again when the drive direction is reversed.

[0071] The further closing process takes place for the other fastening elements or the louvers in an analogous manner, finally, by the closing motion of the next-to-last fastening element **20b**, the rooftop locking of the last fastening element **20a** in the bolt recess **100a** is released. When the crank pin **96** of the raising lever **94**, i.e., the pin which fits into the last fastening element **20a**, reaches the back end **48** of the crank slot **42**, the coupling control part is pushed rearward again by means of the back drive **87**, by which the raising lever **94** is lowered again and all louvers are again in a plane parallel to the roof plane. The closing process therefore take place in such away that some of the louvers are always coupled to one another and move jointly in the closing direction, while the remainder of the louvers are locked with the common coupling element **95**, i.e., on the roof, and cannot participate in the closing motion. The last movable and the first locked louver are each decoupled from one another. To keep mechanical play low, the coupling of the first locked louver to the last movable louver takes place very shortly after unlocking of the first locked louver, i.e. almost simultaneously thereto.

[0072] Opening motion from back to front is described below. In this mode of operation, the rearmost louver **10a** is raised above the sealing edge by swinging the raising lever **94** out. However, the back drive **87** is not turned off in this position, but continues to run, by which the coupling control part **90** is pushed further to the front. In doing so, the bolt recess **91** passes the hammer head **103**, by which the latter swings by form fit into the bolt recess **91**, in turn, this causes the other side of the hammer head **103** to decouple from the roof-mounted locking recess **104**. In this way, the rooftop locking of the coupling element **95** is released and the coupling element **95** is locked instead to the coupling control part **90** so that, as it continues to run, the coupling element **95**, together with the coupling control part **90**, is pushed to the front with reference to the stationary fastening elements **20a**, **20b**, etc. by means of the back drive **87**. The further opening process now runs in the exact kinematic reversal of the above described opening process from front to back, in which the fastening elements are driven and the coupling element **95** and the coupling control part are at rest. Therefore, likewise, the rearmost fastening element **20a** is fully swung out first, decoupled with the next-to-last fastening element **20b**, and in doing so, locked at the same time to the coupling element **95**, etc., so that finally a louver bundle which is pushed together on the front edge of the roof opening **13** is obtained (see **FIG. 3**).

[0073] Alternatively, the louver bundle can also be opened at the same time from the front and from the back, a louver bundle which has been pushed together in the middle of the roof opening **13** being obtained (see **FIG. 4**). During opening from the front, the wind deflector **16** is first raised.

[0074] Regardless of how the louver system has been opened, the louver bundle formed can be pushed as a whole to the front and the back in the roof opening by synchronous activation of the front and back drives so that a maximum of flexibility is ensured.

[0075] Instead of forming the coupling element **95** with several members **97**, **99** which are jointed to one another, the coupling element **95** can also be made in one piece out of elastic material.

[0076] While various embodiments in accordance with the present invention have been shown and described, it is

understood that the invention is not limited thereto, and is susceptible to numerous changes and modifications as known to those skilled in the art. Therefore, this invention is not limited to the details shown and described herein, and includes all such changes and modifications as are encompassed by the scope of the appended claims.

What is claimed is:

1. Motor vehicle roof with a series of cover elements for selectively closing and at least partially exposing a roof opening in a fixed roof surface, the cover elements bordering one another in a closed position to form a flat panel system, each cover element being connected on a narrow edge to a pivotable fastening element which is guided along a roof-mounted guideway for movement between the closed position and a position in which the respective cover element is fully swung out, two adjacent fastening elements being coupled for common motion in opening and closing directions until a first of the two fastening elements has reached the position in which the respective cover element is fully swung out, at which point the two adjacent fastening elements are decoupled enabling relative displacement of the second of the two adjacent fastening elements relative to the first as the second moves into the position in which the respective louver connected thereto is fully swung out, and under the influence of motion of the second of the two adjacent fastening elements in the opening direction, the first fastening element is locked with a fastening element of a louver already in the fully swung out position thereof, said locking being automatically released under the influence of motion of the second of the two adjacent fastening elements in the closing direction; wherein at least some of all fully swiveled-out fastening elements are securely engaged to a common coupling element which is movable along the roof-mounted guideway and is fixable relative to the guideway.

2. Motor vehicle roof as claimed in claim 1, wherein the coupling element is lockable to the roof-mounted guideway in at least one position.

3. Motor vehicle roof as claimed in claim 2, wherein there is a coupling control part which is driven by a drive to be displaced along the guideway, the coupling control part being lockable to the coupling element.

4. Motor vehicle roof as claimed in claim 3, wherein the coupling element has a locking device for locking to one of the roof-mounted guide rail and the coupling control part, said locking device being actuated by displacement of the coupling control part with reference to the coupling element in said closed position, such that it releases the locking to the roof-mounted guide rail and it engages the locking to the coupling control part.

5. Motor vehicle roof as claimed in claim 4, wherein the locking device comprises a pivoting bolt hammer which establishes the corresponding locking by engaging in bolt recesses in one of the roof-mounted guideway and the coupling control element.

6. Motor vehicle roof as claimed in claim 3, comprising an additional drive for driving a frontmost fastening element.

7. Motor vehicle roof as claimed in claim 3, wherein, in said closed position, the coupling element is locked to the roof-mounted guideway, while the coupling control part is displaceable with reference to the coupling element; wherein, at the start of opening motion, the coupling control part is pushed to the front onto the coupling element, by

which the rearmost fastening element is swung out, the coupling control part releasing the locking of the coupling element to the guideway and causing locking of the coupling element to the coupling control part; and wherein pushing of the coupling control element towards the front causes swing out and then locking of the rearmost fastening element to the coupling element, and by continuous pushing of the coupling control element to the front, finally, the cover elements are pushed together to the front to form a bundle.

8. Motor vehicle roof as claimed in claim 7, wherein the coupling control part engages the rearmost fastening element such that displacement of the coupling control part along the roof-mounted guideway causes the rearmost fastening element to swing out or back depending on the direction of movement.

9. Motor vehicle roof as claimed in claim 8, wherein the coupling control part actuates a raising lever which is pivotally attached to the coupling element and which interacts with the rearmost fastening element.

10. Motor vehicle roof as claimed in claim 9, wherein the raising lever is made as a crank lever which, by means of a

crank pin, fits into a crank slot in the last fastening element, the raising lever being provided with another crank slot into which another crank pin, which is on the coupling control part, fits.

11. Motor vehicle roof according to claim 1, wherein the coupling element is comprise of plural pivotally interconnected members.

12. Motor vehicle roof as claimed in claim 11, wherein a coupling element member is provided for each fastening element except for a frontmost fastening element.

13. Motor vehicle roof as claimed in 1, wherein locking between the fastening elements and the coupling element takes place via a locking element which is made as a bolt rocker which is mounted in a middle section thereof, has a bolt part on one and an actuating arm on another end.

14. Motor vehicle roof as claimed in claim 13, wherein the coupling element, for each fastening element except for a frontmost fastening element, has a bolt recess for accommodating the bolt part.

* * * * *