

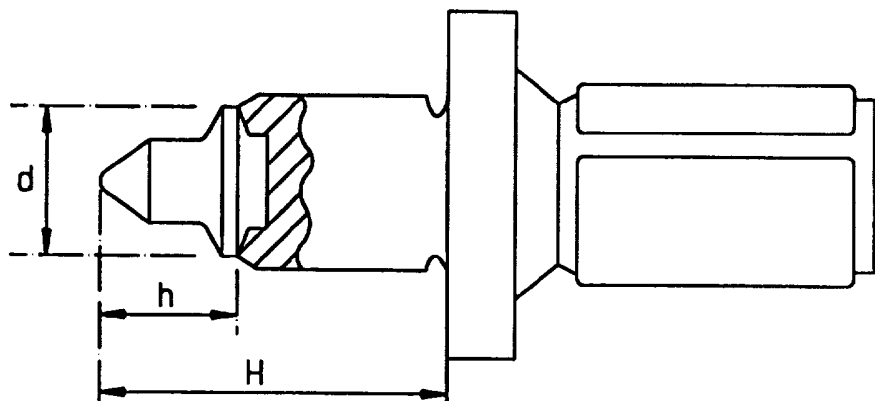

INTERNATIONAL APPLICATION PUBLISHED UNDER THE PATENT COOPERATION TREATY (PCT)

<p>(51) International Patent Classification : Not classified</p>	<p>A2</p>	<p>(11) International Publication Number: WO 96/13968 (43) International Publication Date: 17 May 1996 (17.05.96)</p>
<p>(21) International Application Number: PCT/UA94/00029 (22) International Filing Date: 28 October 1994 (28.10.94) (71) Applicant (for all designated States except US): I.N. FRANTSEVICH INSTITUTE FOR PROBLEMS OF MATERIALS SCIENCE [UA/UA]; 3 Krzhizhanovsky Street, Kiev, 252142 (UA). (72) Inventor; and (75) Inventor/Applicant (for US only): MIKHAILOV, Arkadi, A. [UA/UA]; Apartment 29, 51, Predslavinskaya Street, Kiev, 252006 (UA).</p>		<p>(81) Designated States: AM, AT, AU, BB, BG, BR, BY, CA, CH, CN, CZ, DE, DK, EE, ES, FI, GB, GE, HU, JP, KE, KG, KP, KR, KZ, LK, LR, LT, LU, LV, MD, MG, MN, MW, NL, NO, NZ, PL, PT, RO, RU, SD, SE, SI, SK, TJ, TT, UA, US, UZ, VN, European patent (AT, BE, CH, DE, DK, ES, FR, GB, GR, IE, IT, LU, MC, NL, PT, SE), OAPI patent (BF, BJ, CF, CG, CI, CM, GA, GN, ML, MR, NE, SN, TD, TG), ARIPO patent (KE, MW, SD, SZ).</p> <p>Published Without international search report and to be republished upon receipt of that report.</p>

(54) Title: CUTTING INSERT



(57) Abstract

A cutting insert of a hard material comprising a generally conical tip portion which includes a tip and a base; a first tapered conical portion having first and second ends, with the first end adjacent the base of the tip portion and the second end having a greater diameter than that of the first end; a transition portion having first and second ends and defining a radius of curvature therebetween, with the first end adjacent the second end of the first tapered conical portion, a second tapered conical portion having first and second ends with the first end adjacent the second end of the transition portion and the second end having a greater diameter than the first end; a shoulder portion having first and second ends with the first end adjacent the second end of the second tapered conical portion and having a greater diameter thereto. Also, an extracting tool comprising an elongated tool body having an end which is configured and dimensioned to provide a support surface for a cutting insert as described above.

FOR THE PURPOSES OF INFORMATION ONLY

Codes used to identify States party to the PCT on the front pages of pamphlets publishing international applications under the PCT.

AT	Austria	GB	United Kingdom	MR	Mauritania
AU	Australia	GE	Georgia	MW	Malawi
BB	Barbados	GN	Guinea	NE	Niger
BE	Belgium	GR	Greece	NL	Netherlands
BF	Burkina Faso	HU	Hungary	NO	Norway
BG	Bulgaria	IE	Ireland	NZ	New Zealand
BJ	Benin	IT	Italy	PL	Poland
BR	Brazil	JP	Japan	PT	Portugal
BY	Belarus	KE	Kenya	RO	Romania
CA	Canada	KG	Kyrgystan	RU	Russian Federation
CF	Central African Republic	KP	Democratic People's Republic of Korea	SD	Sudan
CG	Congo	KR	Republic of Korea	SE	Sweden
CH	Switzerland	KZ	Kazakhstan	SI	Slovenia
CI	Côte d'Ivoire	LI	Liechtenstein	SK	Slovakia
CM	Cameroon	LU	Luxembourg	SN	Senegal
CN	China	LK	Sri Lanka	TD	Chad
CS	Czechoslovakia	LV	Latvia	TG	Togo
CZ	Czech Republic	MC	Monaco	TJ	Tajikistan
DE	Germany	MD	Republic of Moldova	TT	Trinidad and Tobago
DK	Denmark	MG	Madagascar	UA	Ukraine
ES	Spain	ML	Mali	US	United States of America
FI	Finland	MN	Mongolia	UZ	Uzbekistan
FR	France			VN	Viet Nam
GA	Gabon				

-1-

CUTTING INSERT**Field of the Invention**

This invention relates articles of manufacture that are useful for breaking, cutting, or tearing hard materials, such as asphalt, concrete, and granite. In particular, the present invention provides a tool comprising a tool body and a cutting insert secured thereto. This tool body is composed of a ferrous metal while the insert is composed of an appropriately formulated hard alloy material.

Background of the Invention

Rotatable tools currently in use for breaking, cutting, or tearing construction materials such as asphalt road surfaces conventionally comprise a shank that may be enveloped by a split sleeve, a flange, a body, and a cutting insert. A typical prior art cutting tool is depicted in Figure 1, wherein 1 is a cutting insert that would normally be made of a hard alloy, 2 is a tool body that would typically be made of steel, 3 is a protective flange, 4 is the tool shank, and 5 is a split sleeve.

The functions of the various parts of the tool are as follows:

- 1 - the cutting insert made of a hard alloy is the main breaking element of the tool;
- 2 - the structural body of the tool comes into direct contact with the broken construction material and therefore works in the zone of abrasive wear;
- 3 - the protective flange serves mainly for protection of the mounting socket in the machine against penetration of abrasive particles into it; and
- 4,5 - the shank and split sleeve permit the tool to be mounted and rotated upon a tool holder, one of many such mounted on a milling or digging machine.

U.S. Patents Nos. 5,161,859 and 4,938,538 describe a tool for breaking hard materials, for instance for milling in poured asphalt. As disclosed in the patents, with

-2-

reference to Figure 2, in order to protect a steel body into which the cutting insert is set against abrasive wear, the hard metal insert comprises a conical tip portion 12 joining a cylindrical portion 17" which in turn joins a cylindrical portion 13 of a greater diameter through an intermediate portion 17' having a constant radius of curvature. Rear contact surface 20 is generally planar. However, it might be recessed for instance with a half-spherical or a general W-shape. The patentees indicate that the concave portion 17' and shoulder 13, which are joined together by the intermediate portion 17' with its constant radius of curvature, protects the steel in the tool body against premature wear. Presumably the curved transition from a smaller cylinder to a bigger cylinder provides a deflector which diverts particles of broken abrasive material away from the steel body.

The proposed idea is quite logical. However, in practice this is true only for an isolated hard metal insert, but not for the combination of the insert and tool body joined together. The inventors of the tool according to U.S. Patent No. 5,161,859 did not take into account the fact that the entire working portion -- both cutting insert and steel body -- of the tool works immersed into a mass of broken construction material, the hard metal insert being only 0.4 to 0.45 of the total length of the tool portion subject to abrasive wear. Hard material, such as asphalt, broken by the hard metal insert comes into contact with the steel body thus causing it to wear away rapidly, as a result of which the hard metal tip is broken away from the tool.

Summary of the Invention

With this drawback of the prior art tool in view, we have proposed a new design of the hard metal cutting insert which cooperates well with the remaining portion of the tool to resist abrasive wear. The proposed design provides an increase of the ratio of the diameter to the working length of the cutting insert of up to 0.5-0.65.

-3-

The increase of this ratio requires a more rigid structure of the hard metal cutting insert since the intermediate portion of the hard metal insert will be much longer. To meet this requirement, a new design of a hard metal insert
5 has been developed that makes it possible to increase the service life of the tool and to provide reliable protection of the steel body against wear.

Thus the present invention provides a cutting insert of a hard material that comprises a generally conical tip
10 portion which includes a tip and a base; a first tapered conical portion having first and second ends, with the first end adjacent the base of the tip portion and the second end having a greater diameter than that of the first end; a transition portion having first and second
15 ends and defining a radius of curvature therebetween, with the first end adjacent the second end of the first tapered conical portion; a second tapered conical portion having first and second ends with the first end adjacent the second end of the transition portion and the second
20 end having a greater diameter than the first end; and a shoulder portion having first and second ends with the first end adjacent the second end of the second tapered conical portion and having a greater diameter thereto.

The present invention also provides an extracting
25 tool comprising an elongated tool body having an end which is configured and dimensioned to provide a support surface for a cutting insert such as that described above.

Brief Description of the Drawings

Fig. 1 shows a side view, partially in section, of a
30 prior art tool for breaking hard material;

Fig. 2 shows a side view of the cutting insert in the tool according to U.S. Patent No. 5,161,859;

Fig. 3 shows a side view of a tool according to U.S. Patent No. 5,161,859;

35 Fig. 4 shows a side view of a tool according to the present invention; and

Fig. 5 shows a side view of the cutting insert of the

tool according to the present invention.

Description of the Preferred Embodiments

The present invention provides a new design for hard metal cutting inserts that provides good protection for the remaining portion of the tool that would be subject to abrasive wear. As noted above, this cutting insert is composed of a hard material and comprises a generally conical tip portion which includes a tip and a base; a first tapered conical portion having first and second ends, with the first end adjacent the base of the tip portion and the second end having a greater diameter than that of the first end; a transition portion having first and second ends and defining a radius of curvature therebetween, with the first end adjacent the second end of the first tapered conical portion; a second tapered conical portion having first and second ends with the first end adjacent the second end of the transition portion and the second end having a greater diameter than the first end; and a shoulder portion having first and second ends with the first end adjacent the second end of the second tapered conical portion and having a greater diameter thereto.

In the above-described insert, it is preferred that the difference in the diameters of the first and second ends of the second tapered conical portion be greater than the difference in the diameters of the first and second ends of the first tapered conical portion. It is also preferred that the length of the first tapered conical portion be greater than the length of the tip portion.

The second end of the shoulder portion of the insert may include an extension for mounting the insert on a tool. The diameter d of the shoulder is preferably equal to or greater than the length h of the insert, and the ratio of d/h is preferably between about 8/10 and 14/11.

In a preferred embodiment of the insert, a line tangent to the outer surface of the first tapered conical portion forms an angle of between about 2 and 15°, more

-5-

preferably between about 5 and 10°, with the longitudinal axis of the insert. Likewise, a line tangent to the outer surface of the second tapered conical portion forms an angle of between about 20 to 45°, more preferably between about 25 to 35°, with a line that is perpendicular to the longitudinal axis of the insert.

It is also preferred that the difference in the diameters of the first and second ends of the second tapered conical portion be between two and five times greater than the difference in the diameters of the first and second ends of the first tapered conical portion, and that the length of the first tapered conical portion be between two and four times greater than the length of the tip portion.

The hard material that is currently most preferred for the cutting insert is a tungsten carbide/cobalt alloy as described in our copending application entitled THERMAL HARDENING OF ALLOYS AND IMPLEMENTATION IN TOOLS, Attorney's Docket No. 7989-005, filed on even date herewith. The entire disclosure of that application is hereby expressly incorporated by reference.

As illustrated in Figures 3 and 4, the novel design according to the present invention provides an increase of the ratio d/H of up to 0.5-0.65. The increase of this ratio requires a more rigid structure of the hard metal cutting insert since the portion of the hard metal insert between the tip and the flange will be much longer. To meet this requirement, we have discovered a new design of a hard metal insert which makes it possible to increase the service life of hard metal material and to provide a reliable protection of the steel body against wear.

As shown in Figure 5, the cutting insert in the tool according to the present invention comprises an upper conical portion 6, middle tapered conical portion 7, and lower tapered conical portion 9, the middle tapered portion 7 joining the lower tapered portion 9 through an intermediate portion 8 of varying radius of curvature.

-6-

The middle tapered portion 7 should have a minimum inclination of its generatrix, but at the same time it should provide sufficient strength to the cutting insert as a whole, considering that the tapered portion 7 has a relative great length. The middle tapered portion 7 joins a cylinder 10 whose diameter can be found from an optimum relationship $d/H = 0.5$ to 0.65 with h/H 0.55 to 0.6 . Such a design of the cutting insert provides reliable protection to the steel body against abrasive wear. Rear contact surface 11 may be conical, flat, or concave, and might be recessed for instance with a half-spherical or a general W-shape.

Various features of the novel cutting insert design according to the present invention may be implemented as follows. The difference in the diameters of the first and second ends of the second tapered conical portion will generally be greater than the difference in the diameters of the first and second ends of the first tapered conical portion, and the length of the first tapered conical portion will generally be greater than the length of the tip portion. The second end of the shoulder portion may include an extension for mounting the insert on a tool. The diameter d of the shoulder is equal to or greater than the length h of the insert, with the ratio of d/h preferably being between about $8/10$ and $14/11$. A line tangent to the outer surface of the first tapered conical portion will generally form an angle θ of between about 2 and 15° , preferably between about 5 and 10° , with the longitudinal axis of the insert. A line tangent to the outer surface of the second tapered conical portion will generally form an angle ϕ of between about 20 to 45° , preferably between about 25 to 35° , with a line that is perpendicular to the longitudinal axis of the insert. The difference in the diameters of the first and second ends of the second tapered conical portion will normally be between two and five times greater than the difference in the diameters of the first and second ends of the first

-7-

tapered conical portion, and the length of the first tapered conical portion will normally be between two and four times greater than the length of the tip portion.

Another aspect of the present invention comprises an
5 extracting tool that has an elongated tool body having an end which is configured and dimensioned to provide a support surface for a cutting insert and incorporates a cutting insert as described above comprising a generally conical tip portion which includes a tip and a base; a
10 first tapered conical portion having first and second ends, with the first end adjacent the base of the tip portion and the second end having a greater diameter than that of the first end; a second tapered conical portion having first and second ends with the second end having a
15 greater diameter than the first end; a shoulder portion having first and second ends with the first end adjacent the second end of the second tapered conical portion and having a greater diameter thereto, said cutting insert mounted upon the support surface of the elongated tool
20 body.

The support surface of the elongated tool body may include a recess and the second end of the shoulder portion of the cutting insert may include an extension portion configured and dimensioned to be received by the
25 recess. The cutting insert may be attached to the elongated tool body by a brazed metal connection. The diameter d of the shoulder of the insert is preferably less than the length H of the insert and elongated tool body and the ratio of d/H is preferably between about 0.5
30 and 0.65. The length h of the insert is preferably less than the length H of the insert and elongated tool body and the ratio of h/H is preferably between about 0.55 to 0.6. The diameter d of the shoulder of the insert may be less than the length H of the insert and elongated tool
35 body to provide a ratio of d/H of between about 0.5 and 0.65, with the length h of the insert being less than the length H and providing a ratio of h/H of between about

0.55 to 0.6.

Example

Given below as an example are the results of tool tests carried out during the milling of an asphalt road surface:

Tool dimensions: $H = 38\text{mm}$, $h = 22\text{ mm}$, $d = 24\text{ mm}$, $d/H = 24/38 = 0.63$, $h/H = 22/38 = 0.57$.

Upon removal of 12,000 linear feet of asphalt, with the layer removed being 40 to 60 mm thick, the wear of the cutting insert tip was only 10% and there was no noticeable wear of the rest of the tool head. These results demonstrate that the proposed design of a tool for breaking or excavating of asphalt and other hard materials is far more effective than that of the closest prior art.

While the present invention has been described with reference to a specific embodiment thereof, those skilled in the art will readily conceive of other embodiments based upon the principals and generic teachings hereinabove. Applicants propose, therefore, to be limited in their patent only by the full spirit and scope of the invention as set forth in the appended claims.

THE CLAIMS

What is claimed is:

1. A cutting insert of a hard material comprising: a generally conical tip portion which includes
5 a tip and a base;
a first tapered conical portion having first and second ends, with the first end adjacent the base of the tip portion and the second end having a greater diameter than that of the first end;
10 a transition portion having first and second ends and defining a radius of curvature therebetween, with the first end adjacent the second end of the first tapered conical portion,
a second tapered conical portion having first and second ends with the first end adjacent the second end of
15 the transition portion and the second end having a greater diameter than the first end;
a shoulder portion having first and second ends with the first end adjacent the second end of the second
20 tapered conical portion and having a greater diameter thereto.
2. The insert of claim 1 wherein the difference in the diameters of the first and second ends of the second tapered conical portion is greater than the
25 difference in the diameters of the first and second ends of the first tapered conical portion.
3. The insert of claim 1 wherein the length of the first tapered conical portion is greater than the length of the tip portion.
- 30 4. The insert of claim 1 wherein the second end of the shoulder portion includes an extension for mounting the insert on a tool.
5. The insert of claim 1 wherein the diameter d of the shoulder is equal to or greater than the length h
35 of the insert.
6. The insert of claim 5 wherein the ratio of d/h is between about 8/10 and 14/11.

-10-

7. The insert of claim 1 wherein a line tangent to the outer surface of the first tapered conical portion forms an angle of between about 2 and 15° with the longitudinal axis of the insert.
- 5 8. The insert of claim 1 wherein a line tangent to the outer surface of the first tapered conical portion forms an angle of between about 5 and 10° with the longitudinal axis of the insert.
- 10 9. The insert of claim 1 wherein a line tangent to the outer surface of the second tapered conical portion forms an angle of between about 20 to 45° with a line that is perpendicular to the longitudinal axis of the insert.
- 15 10. The insert of claim 8 wherein a line tangent to the outer surface of the second tapered conical portion forms an angle of between about 25 to 35° with a line that is perpendicular to the longitudinal axis of the insert.
- 20 11. The insert of claim 1 wherein the difference in the diameters of the first and second ends of the second tapered conical portion is between two and five times greater than the difference in the diameters of the first and second ends of the first tapered conical portion.
- 25 12. The insert of claim 1 wherein the length of the first tapered conical portion is between two and four times greater than the length of the tip portion.
- 30 13. An extracting tool comprising: an elongated tool body having an end which is configured and dimensioned to provide a support surface for a cutting insert; and
- 35 a cutting insert comprising a generally conical tip portion which includes a tip and a base; a first tapered conical portion having first and second ends, with the first end adjacent the base of the tip portion and the second end having a greater diameter than that of the first end; a second tapered conical portion having first and second ends with the second end having a greater diameter than the first end; a shoulder portion having

-11-

first and second ends with the first end adjacent the second end of the second tapered conical portion and having a greater diameter thereto, said cutting insert mounted upon the support surface of the elongated tool
5 body.

14. The tool of claim 13 wherein the support surface of the elongated tool body includes a recess and the second end of the shoulder portion of the cutting insert includes an extension portion configured and dimensioned to be received by the recess.
10

15. The tool of claim 14 wherein the cutting insert is attached to the elongated tool body by a brazed metal connection.

16. The tool of claim 13 wherein the diameter d of the shoulder of the insert is less than the length H of the insert and elongated tool body.
15

17. The tool of claim 16 wherein the ratio of d/H is between about 0.5 and 0.65.

18. The tool of claim 13 wherein the length h of the insert is less than the length H of the insert and elongated tool body.
20

19. The tool of claim 18 wherein the ratio of h/H is between about 0.55 to 0.6.

20. The tool of claim 13 wherein the diameter d of the shoulder of the insert is less than the length H of the insert and elongated tool body and provides a ratio of d/H of between about 0.5 and 0.65, with the length h of the insert being less than the length H and providing a ratio of h/H of between about 0.55 to 0.6.
25

30

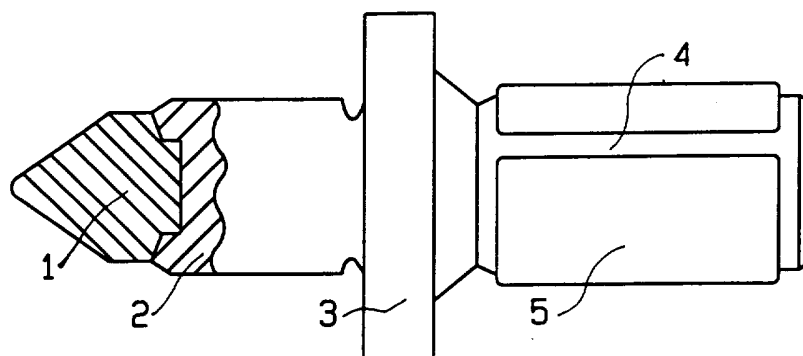

FIG. 1 Prior Art

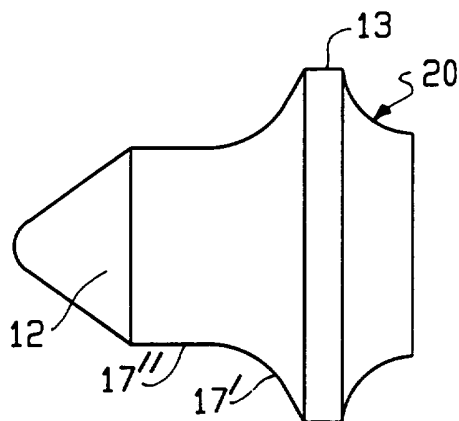

FIG. 2 Prior Art

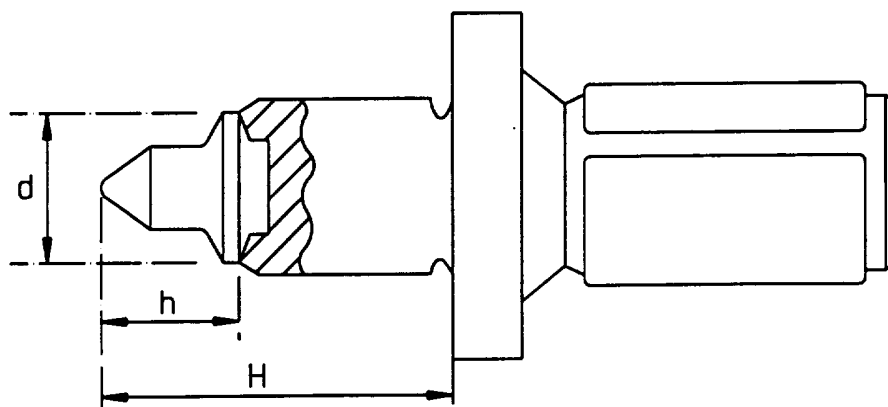

FIG. 3 Prior Art

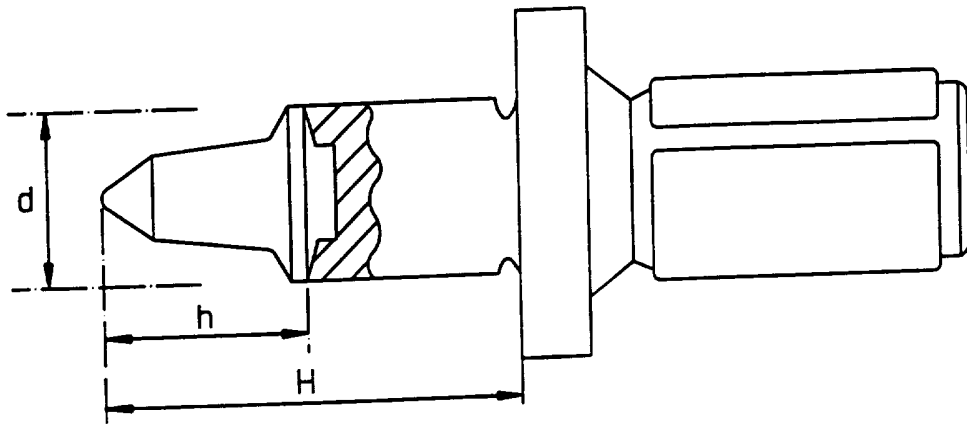

FIG. 4

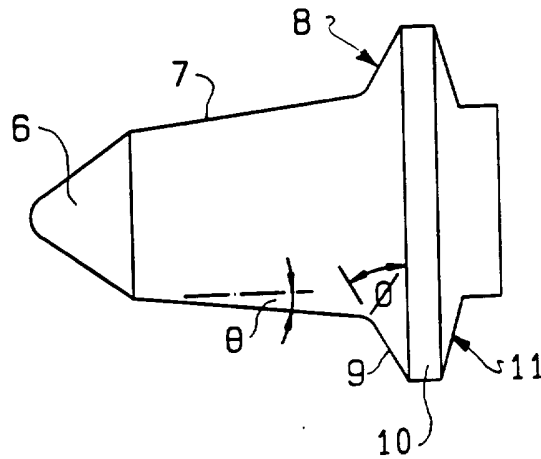

FIG. 5