

(19) World Intellectual Property Organization
International Bureau



(43) International Publication Date
15 September 2011 (15.09.2011)

(10) International Publication Number
WO 2011/110189 A1

(51) International Patent Classification:
B25F 5/02 (2006.01)

(21) International Application Number:
PCT/EP2010/001407

(22) International Filing Date:
6 March 2010 (06.03.2010)

(25) Filing Language: English

(26) Publication Language: English

(71) Applicant: HUSQVARNA AB [SE/SE]; Drottninggatan
2, 561 82 Huskvarna (SE).

(72) Inventors; and

(75) Inventors/Applicants (for US only): BERGQUIST, Os-
kar [SE/SE]; Skolgatan 30A, S-561 35 Huskvarna (SE).
BJÖRNLINGER, Johan [SE/SE]; Kittendorffs Gata 20,
S-561 51 Huskvarna (SE). MARTINSSON, Pär
[SE/SE]; Orrvägen 4, S-556 26 Jönköping (SE).

(74) Agent: GARDENA MANUFACTURING GMBH;
Hans-Lorensen-Strasse 40, 89079 Ulm (DE).

(81) Designated States (unless otherwise indicated, for every
kind of national protection available): AE, AG, AL, AM,

AO, AT, AU, AZ, BA, BB, BG, BH, BR, BW, BY, BZ,
CA, CH, CL, CN, CO, CR, CU, CZ, DE, DK, DM, DO,
DZ, EC, EE, EG, ES, FI, GB, GD, GE, GH, GM, GT,
HN, HR, HU, ID, IL, IN, IS, JP, KE, KG, KM, KN, KP,
KR, KZ, LA, LC, LK, LR, LS, LT, LU, LY, MA, MD,
ME, MG, MK, MN, MW, MX, MY, MZ, NA, NG, NI,
NO, NZ, OM, PE, PG, PH, PL, PT, RO, RS, RU, SC, SD,
SE, SG, SK, SL, SM, ST, SV, SY, TH, TJ, TM, TN, TR,
TT, TZ, UA, UG, US, UZ, VC, VN, ZA, ZM, ZW.

(84) Designated States (unless otherwise indicated, for every
kind of regional protection available): ARIPO (BW, GH,
GM, KE, LS, MW, MZ, NA, SD, SL, SZ, TZ, UG, ZM,
ZW), Eurasian (AM, AZ, BY, KG, KZ, MD, RU, TJ,
TM), European (AT, BE, BG, CH, CY, CZ, DE, DK, EE,
ES, FI, FR, GB, GR, HR, HU, IE, IS, IT, LT, LU, LV,
MC, MK, MT, NL, NO, PL, PT, RO, SE, SI, SK, SM,
TR), OAPI (BF, BJ, CF, CG, CI, CM, GA, GN, GQ, GW,
ML, MR, NE, SN, TD, TG).

Published:

— with international search report (Art. 21(3))

(54) Title: BATTERY DRIVEN ELECTRIC TOOL

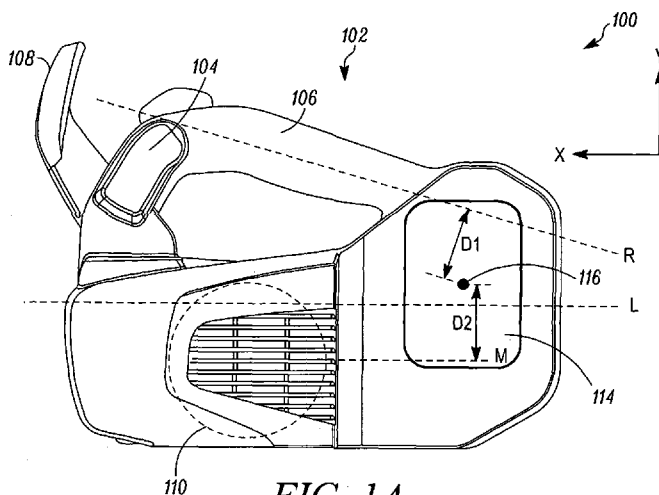

FIG. 1A

(57) Abstract: A balanced electric power tool (100, 700) is provided. The electric power tool (100, 700) may include a tool body (102, 702) and one or more working implements coupled to the tool body (102, 702). Further, the one or more working implements may be connected to an electric drive motor. The electric power tool (100, 700) further includes at least one battery (114, 712), which may include at least one battery cell (204), for supplying the electric drive motor (110, 710) with electrical energy. The electric power tool (100, 700) further includes a front handle (104, 704) and a rear handle (106, 706). The front handle (104, 704) is located at least partly in front of the rear handle (106, 706) along a longitudinal axis (L, L') of the electric power tool (100, 700). Further, the overall centre of gravity (116) of the electric power tool (100, 700) is located proximate to the rear handle (106, 706) in a vertical direction.



WO 2011/110189 A1

BATTERY DRIVEN ELECTRIC TOOL

TECHNICAL FIELD

The present invention relates to an electric power tool. In particular, the present invention relates to an electric power tool which is powered by a battery.

BACKGROUND

Battery powered hand-held electric power tools, such as, but not limited to, chainsaws, line trimmers, and hedge trimmers are well known in the art. Typically, a battery may be detachably attached to an electric power tool and provides electrical energy to an electric drive motor. Hand-held electric power tools may also include a front handle and a rear handle to grip and manipulate the power tool. The drive motor and the battery may be of significant weight to provide sufficient power and duration for various operations, thereby increasing the overall weight of the electric power tool. The locations of the centre of gravity of the battery and the drive motor in the electric power tool are crucial to provide an operator with ease of handling and good balance during operation despite the increased overall weight.

Typically, the location of the drive motor may be fixed relative to other components whereas the location of the battery may be varied. An improper positioning of the centre of gravity of the battery may result in an imbalance of the electric power tool and increased operator fatigue during operation.

Generally, in the art, the positioning of the battery and the motor results in the front handle to be arranged above the overall centre of gravity of the electric power tool. However, such a location of the overall centre of gravity may not provide sufficient balance of the hedge trimmer during operation.

In light of the foregoing, there is a need for a battery powered hand-held electric power tool that may provide better handling and balance during operation of the electric power tool.

SUMMARY

In view of the above, it is an objective of the present invention to solve or at least reduce the problems discussed above. In particular, the objective is to provide an

improved electric power tool, which is powered by a battery, such that the electric power tool may provide good handling and balance during operation.

The objective is at least partially achieved according to a novel electric power tool described in claim 1. The electric power tool includes a tool body, one or more working implements coupled to the tool body, an electric drive motor drivably connected to the one or more working implements, and at least one battery connected to the electric drive motor for supplying it with electrical energy. The tool body includes a front handle and a rear handle such that the front handle is located at least partly in front of the rear handle along a longitudinal axis. Further, the overall centre of gravity of the electric power tool is located proximate to the rear handle in a vertical direction. In an aspect of the present invention, proximity of the overall centre of gravity to the rear handle in the vertical direction may improve handling and balance of the electric power tool during operation.

According to claim 2, the battery is provided proximate to the rear handle in the vertical direction. The overall centre of gravity of the electric power tool may be located proximate to the drive motor in absence of the battery. Such a location of the centre of gravity of the battery may shift the overall centre of gravity of the electric power tool towards the rear handle in the vertical direction.

According to claim 3, the centre of gravity of the battery is located on a mid-plane of the rear handle in a substantially lateral direction. Further, according to claim 4, the battery contains the mid-plane of the rear handle in the substantially lateral direction. Alternatively, according to claim 5, the battery is located sideways of the mid-plane of the rear handle in the substantially lateral direction. The three alternative configurations of the battery with respect to the mid-plane of the rear handle may result in an improved balancing of the electric power tool in the substantially lateral direction.

According to claim 6, the battery is located at least partly behind the rear handle along the longitudinal axis. Alternatively, according to claim 7, the battery is located at least partly in front of the rear handle along the longitudinal axis.

According to claim 8, wherein the battery is located at least partly behind the electric drive motor along the longitudinal axis.

According to claim 9, the battery is removably attached to the tool body substantially from left.

According to claim 10, the battery is removably attached to the tool body substantially from right.

According to claim 11, the battery is removably attached to the tool body substantially from above.

According to claim 12, the battery is removably attached to the tool body substantially from below.

According to claim 13, the battery is removably attached to the tool body substantially from rear.

According to claim 14, the at least one battery cell is substantially parallel to a motor shaft.

According to claim 15, the electric power tool is one of a chain saw, a hedge trimmer, or a line trimmer.

BRIEF DESCRIPTION OF THE DRAWINGS

The invention will in the following be described in more detail with reference to the enclosed drawings, wherein:

FIG. 1A illustrates a side view of an electric power tool, according to an embodiment of the present invention;

FIG. 1B illustrates a rear view of the electric power tool, according to an embodiment of the present invention;

FIG. 2 illustrates a rear view of the electric power tool with a battery removably attached to the electric power tool from left, according to an embodiment of the present invention;

FIG. 3 illustrates a rear view of the electric power tool with the battery removably attached to the electric power tool from right, according to an embodiment of the present invention;

FIG. 4 illustrates a side view of the electric power tool with the battery removably attached to the electric power tool from above, according to an embodiment of the present invention;

FIG. 5 illustrates a side view of the electric power tool with the battery removably attached to the electric power tool from below, according to an embodiment of the present invention;

FIG. 6 illustrates a side view of the electric power tool with the battery removably attached to the electric power tool from rear, according to an embodiment of the present invention;

FIG. 7 illustrates a side view of the electric power tool with rear handle configuration, according to another embodiment of the present invention.

DESCRIPTION OF EMBODIMENTS

The present invention will be described more fully hereinafter with reference to the accompanying drawings, in which example embodiments of the invention incorporating one or more aspects of the present invention are shown. This invention may, however, be embodied in many different forms and should not be construed as limited to the embodiments set forth herein; rather, these embodiments are provided so that this disclosure will be thorough and complete, and will fully convey the scope of the invention to those skilled in the art. For example, one or more aspects of the present invention can be utilized in other embodiments and even other types of devices. In the drawings, like numbers refer to like elements.

FIGS. 1A and 1B illustrate an example chain saw **100**, according to an embodiment of the present invention. The chain saw **100** (hereinafter referred to as the “electric power tool **100**”) may be used in gardening or forestry applications. It is apparent to a person who is ordinarily skilled in the art that the present invention may also be used in any other battery powered hand-held equipment with two handles, such as but not limited to, line trimmers, hedge trimmers, rotary saws, or other cutting or pruning tools without departing from the essence of the present invention. In addition, any suitable size, shape or type of elements or materials could be used.

FIGS. 1A and 1B further illustrate a co-ordinate system for the electric power tool **100**. An x-axis is substantially parallel to a longitudinal axis **L** of the electric

power tool **100**. As shown in FIG. 1A, y-axis is substantially perpendicular the longitudinal axis **L** of the electric power tool **100**.

Further, as used herein, the terms “longitudinal direction”, “lateral direction”, and “vertical direction” indicate a direction relative to the electric power tool **100**. The term “longitudinal direction”, without further specificity, is a reference to a direction substantially parallel to the longitudinal axis **L**, and thus, the x-axis. The terms “vertical direction” and “lateral direction”, without further specificity, are a reference to directions that are substantially parallel to the y-axis and the z-axis respectively. The terms “front” and “behind” with respect to a part or portion of the electric power tool **100** may in general refer to sides of the part or portion along the longitudinal direction, “front” being further from a user than “behind” in a working position of the electric power tool **100**. The terms “top” and “below” may in general refer to sides of the electric power tool **100** substantially along the y-axis, “top” and “below” being at the top and the bottom respectively in a working position of the electric power tool **100**. The terms “left” and “right” may generally refer to left and right sides respectively of the electric power tool **100** along the z-axis from the point of view of the user in the working position of the electric power tool **100**. The term “oblique” may refer to any non-orthogonal direction or alignment.

In an embodiment of the present invention, the electric power tool **100** may include a tool body **102** and one or more working implements (not shown) that are coupled to the tool body **102**. In an embodiment of the present invention, the working implements may include a toothed chain supported on a guide bar. The guide bar may be attached to tool body **102** via one or more fasteners. Further, a drive sprocket and an idler sprocket may be present at a proximate end and a distal end of the guide bar respectively with respect to the tool body **102**.

In an embodiment of the present invention, the tool body **102** may include a front handle **104** and a rear handle **106**. In an embodiment of the present invention, the front handle **104** may be located at least partly in front of the rear handle **106** along the longitudinal axis **L**. In various embodiments of the present invention, at least one of the front handle **104** or the rear handle **106** may include vibration absorbing means, such as but not limited to, springs, rubber members, and the like. Further, the front handle **104** and/or the rear handle **106** may also include ribbed portions (not shown) to enable a better grip for the electric power tool **100**. In an

embodiment of the present invention, a guard **108** may be present to safeguard the user during a cutting operation. Further, the tool body **102** may also include a cover for safety and smooth functioning of various moving parts.

In an embodiment of the present invention, an electric drive motor **110** may be drivably connected to the drive sprocket. The electric drive motor **110** may include a motor shaft **112** which may be connected to the drive sprocket via suitable transmission means (not shown), such as, but not limited to, one or more gears, belt drive, friction drive, or any combination of these. The transmission means may be utilized to selectively drive the drive sprocket at one or more speeds. The electric drive motor **110** may be an electrically powered motor, such as, but not limiting to, AC motor, DC motor, and the like. In an embodiment of the present invention, the speed and torque of the electric drive motor **110** may be continuously or discretely varied by suitable control means. The control means may include one or more sensors to sense various parameters of the electric drive motor, for example, speed, torque etc. The sensed parameters may then be utilized to control the speed and/or torque of the electric drive motor **110**. As shown in FIG. 1B, the electric drive motor **110** may be located on the left side of the tool body **102**. However, other alignments of the electric drive motor **110** with respect to the tool body **102** may be possible, without deviating from the scope of the present invention.

In an embodiment of the present invention, at least one battery **114** may be provided in the tool body **102** to selectively supply electrical energy to the electric drive motor **110**. In an embodiment of the present invention, the battery **114** may be removably attached to the tool body **102**. The rated power and other specifications of the electric drive motor **110** and the battery **114** may be selected based on various parameters, such as, but not limited to, power requirements, operational durations, expected life, cost, weight, dimensions etc.

Further, as shown in FIG. 1, the battery **114** may be located at least partly behind the rear handle **106** along the longitudinal axis **L**. This configuration of the electric power tool **100** may be generally referred to as the “top handle” configuration. Alternative configurations, such as the “rear handle” configuration, wherein the battery **114** may be located at least partly in front of the rear handle **106** (described in detail in conjunction with FIG. 7), are possible without deviating from the scope of the present invention. As shown in FIG. 1, the centre of gravity **116** of

the battery **114** may be located at a distance **D1** from a rear handle axis **R** and a distance **D2** from an electric drive motor axis **M** in a substantially vertical direction. The rear handle axis **R** and the motor axis **M** may be symmetrically aligned with respect to the rear handle **106** and the electric drive motor **110** respectively in a substantially vertical direction. In an embodiment of the present invention, **D1** may be such that the centre of gravity **116** of the battery **114** may be located proximate to the rear handle **106** in a vertical direction. In absence of the battery **114**, the overall centre of gravity of the electric power tool **100** may be located proximate to the electric drive motor **110**. However, the location of the centre of gravity **116** of the battery **114** discussed in the present invention may shift the overall centre of gravity of the electric power tool **100** towards the rear handle **106** in the vertical direction, which may improve handling and balance of the electric power tool **100** during operation.

In a further embodiment of the present invention, **D1** may be minimized by varying various parameters. The various parameters may include, but not limiting to, location of the battery **114** in the tool body **102** with respect to other components (e.g. **D2**), shape, dimensions, arrangement and/or total weight of the battery **114**, location, weight and/or dimensions of the electric drive motor **110**, etc.

Further, as shown in FIG. 1B, the centre of gravity **116** of the battery **114** may be located on a mid-plane **P** of the rear handle **106** in a substantially lateral direction that is substantially parallel to the z-axis. The mid-plane **P** may be symmetrically aligned with respect to the rear handle **106** in the substantially lateral direction. However, in various other embodiments of the present invention, the battery **114** may contain the mid-plane **P** of the rear handle **106** in the substantially lateral direction. In still other embodiments of the present invention, the battery **114** may be located sideways (left or right) of the mid-plane **P** of the rear handle **106** in the substantially lateral direction. Similar to **D1**, the distance between the centre of gravity **116** and the mid-plane **P** may be minimized by varying various parameters.

FIG. 2 illustrates a cross-sectional view of the battery **114** in a detached condition, according to an embodiment of the present invention. The battery **114** may include a cell housing **202** which may encase one or more battery cells **204**. Though in the example embodiment, the battery cells **204** are shown to be stacked substantially parallel to each other in multiple rows, other configurations (e.g.

staggered) may be envisioned without departing from the scope of the present invention. In various embodiments of the present invention, one or more battery cells **204** may also be placed adjacent to one another in the lateral direction of the electric power tool **100**. In an embodiment of the present invention, the battery cells **204** may be aligned substantially parallel to the motor shaft **112**. However, in other embodiments of the present invention, the battery cells **204** may be obliquely aligned with respect to the motor shaft **112**. The one or more battery cells **204** may be rechargeable Lithium-Ion cells. Inner surfaces of the cell housing **202** may include electrical conductors to electrically connect poles of the one or more battery cells **204** to one or more electric contacts (not shown). In an embodiment of the present invention, the one or more electric contacts may engage electrically with one or more corresponding electrical contacts provided in the tool body **102** to form electrical connections. The battery **114** may also include at least one mechanical mating surface (not shown) to mechanically connect the battery **114** to the tool body **102** of the electric power tool **100**. The mechanical mating surface may include suitable releasable mechanical connections, such as, but not limited to, snap-fit connections, mating recesses and grooves, connections with resilient members (e.g., springs), or a combination of any of these. The mechanical connections may be selectively locked or released without the use of tools. In other embodiments of the present invention, the mechanical connections may require one or more tools to disassemble the battery **114** from the tool body **102** of the electric power tool **100**.

Further, as illustrated in FIGS. 2-6, the battery **114** may be removably attached to the tool body **102** from various directions. For example, as shown by an arrow **200** in FIG. 2, the battery **114** may be removably attached to the tool body **102** substantially from the left. It may be evident that the battery **114** may also be detached in the direction of attachment. In an alternative embodiment of the present invention, as illustrated by an arrow **300** in FIG. 3, the battery **114** may be removably attached to the tool body **102** substantially from the right. In another embodiment of the present invention, as shown by an arrow **400** in FIG. 4, the battery **114** may be removably attached to the tool body **102** substantially from the above. In a still another embodiment of the present invention, as illustrated by an arrow **500** in FIG. 5, the battery **114** may be removably attached to the tool body **102** substantially from the below. In an alternative embodiment of the present invention, as shown by an

arrow **600** in FIG. 6, the battery **114** may be removably attached to the tool body **102** substantially from the rear. It is apparent to a person who is ordinarily skilled in the art that the multiple directions shown in FIGS. 2-6 are for illustrative purposes only and the battery **114** may be removably attached to the tool body **102** from any other direction, for example, a substantially oblique direction, without deviating from the scope of the present invention.

FIG. 7 illustrates a chain saw **700** with a rear handle configuration. The chain saw **700** may include a tool body **702** and one or more working implements (not shown). The tool body **702** may include a front handle **704**, a rear handle **706** and a guard **708**. An electric drive motor **710** may be drivably connected to the working implements. A battery **712** may provide the electrical energy to drive the drive motor **710**. As shown in FIG. 7, the battery **712** may be located at least partly in front of the rear handle **706**. Further, a centre of gravity **714** of the battery **712** may be located at a distance **D1'** from a rear handle axis **R'** and a distance **D2'** from a motor axis **M'** in a substantially vertical direction. The rear handle axis **R'** and the motor axis **M'** may be symmetrically aligned with respect to the rear handle **706** and the electric drive motor **710** respectively in a substantially vertical direction. In an embodiment of the present invention, **D1'** may be such that the centre of gravity **714** of the battery **712** may be located proximate to the rear handle **706** in a vertical direction. In a further embodiment of the present invention, **D1'** may be minimized by varying various parameters.

In the drawings and specification, there have been disclosed preferred embodiments and examples of the invention and, although specific terms are employed, they are used in a generic and descriptive sense only and not for the purpose of limitation, the scope of the invention being set forth in the following claims.

CLAIMS

1. An electric power tool (100, 700) comprising:
 - a tool body (102, 702);
 - one or more working implements coupled to the tool body (102, 702);
 - an electric drive motor (110, 710) drivably connected to the one or more working implements,
 - at least one battery (114, 712) for supplying the electric drive motor (110, 710) with electrical energy, wherein the battery (114, 712) comprises at least one battery cell (204);
 - a front handle (104, 704) and a rear handle (106, 706), wherein the front handle (104, 704) is located at least partly in front of the rear handle (106, 706) along a longitudinal axis (L, L');

characterized in that,

 - the overall centre of gravity of the electric power tool (100, 700) is located proximate to the rear handle (106, 706) in a vertical direction.
2. An electric power tool (100, 700) according to claim 1, wherein the centre of gravity (116, 714) of the battery (114, 712) is provided proximate to the rear handle (106, 706) in the vertical direction to locate the overall centre of gravity of the electric power tool (100, 700) proximate to the rear handle (106, 706) in the vertical direction.
3. An electric power tool (100, 700) according to claim 2, wherein the centre of gravity (116, 714) of the battery (114, 712) is located on a mid-plane P of the rear handle (106, 706) in a substantially lateral direction.
4. An electric power tool (100, 700) according to claim 2, the battery (114, 712) contains the mid-plane P of the rear handle (106, 706) in the substantially lateral direction.
5. An electric power tool (100, 700) according to claim 2, wherein the battery (114, 712) is located sideways of the mid-plane P of the rear handle (106, 706) in the substantially lateral direction.

6. An electric power tool (100) according to claim 1, wherein the battery (114) is located at least partly behind the rear handle along the longitudinal axis (L).
7. An electric power tool (700) according to claim 1, wherein the battery (712) is located at least partly in front of the rear handle (706) along the longitudinal axis L'.
8. An electric power tool (100, 700) according to claim 1, wherein the battery (114, 712) is located at least partly behind the electric drive motor (110, 710) along the longitudinal axis (L, L').
9. An electric power tool (100, 700) according to claim 1, wherein the battery (114, 712) is removably attached to the tool body (102, 702) substantially from left.
10. An electric power tool (100, 700) according to claim 1, wherein the battery (114, 712) is removably attached to the tool body (102, 702) substantially from right.
11. An electric power tool (100, 700) according to claim 1, wherein the battery (114, 712) is removably attached to the tool body (102, 702) substantially from above.
12. An electric power tool (100, 700) according to claim 1, wherein the battery (114, 712) is removably attached to the tool body (102, 702) substantially from below.
13. An electric power tool (100, 700) according to claim 1, wherein the battery (114, 712) is removably attached to the tool body (102, 702) substantially from rear.
14. An electric power tool (100, 700) according to claims 1-13, wherein the at least one battery cell (204) is substantially parallel to a motor shaft (112).
15. An electric power tool (100, 700) according to claims 1-14, wherein the electric power tool (100, 700) is one of a chain saw, a hedge trimmer, or a line trimmer.

1/6

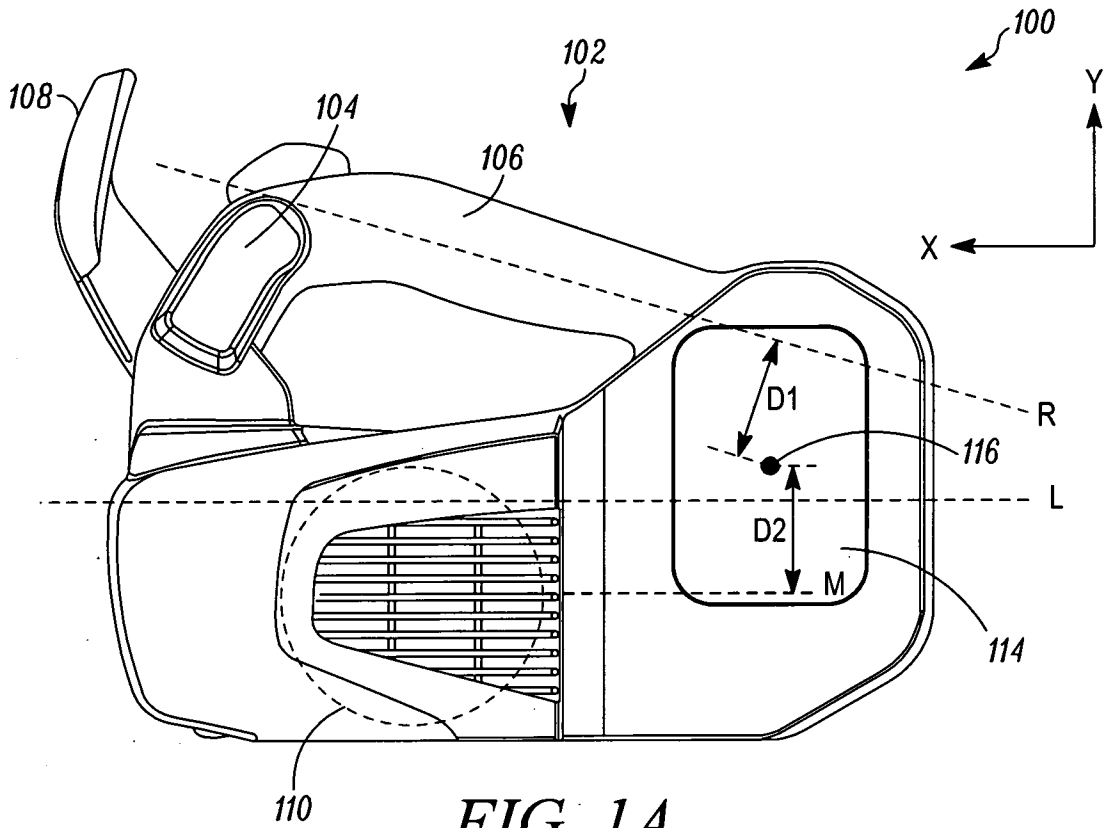

FIG. 1A

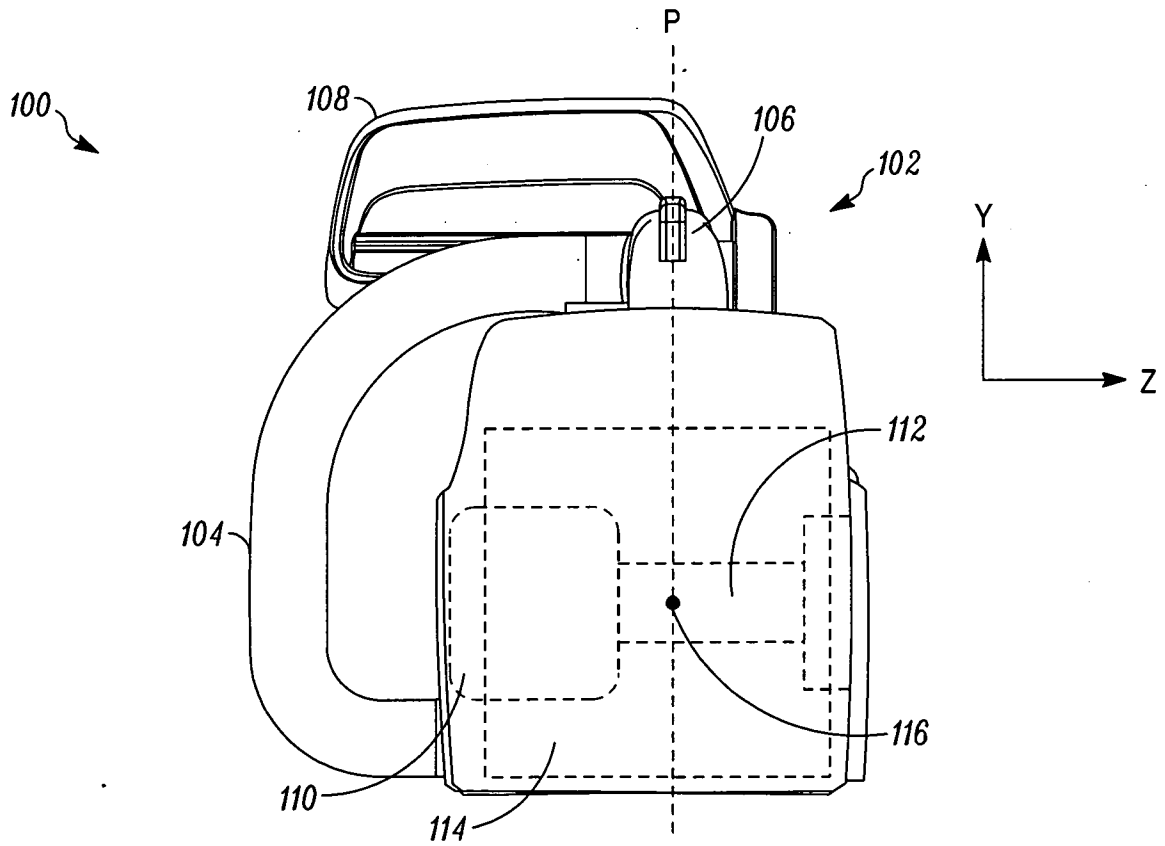

FIG. 1B

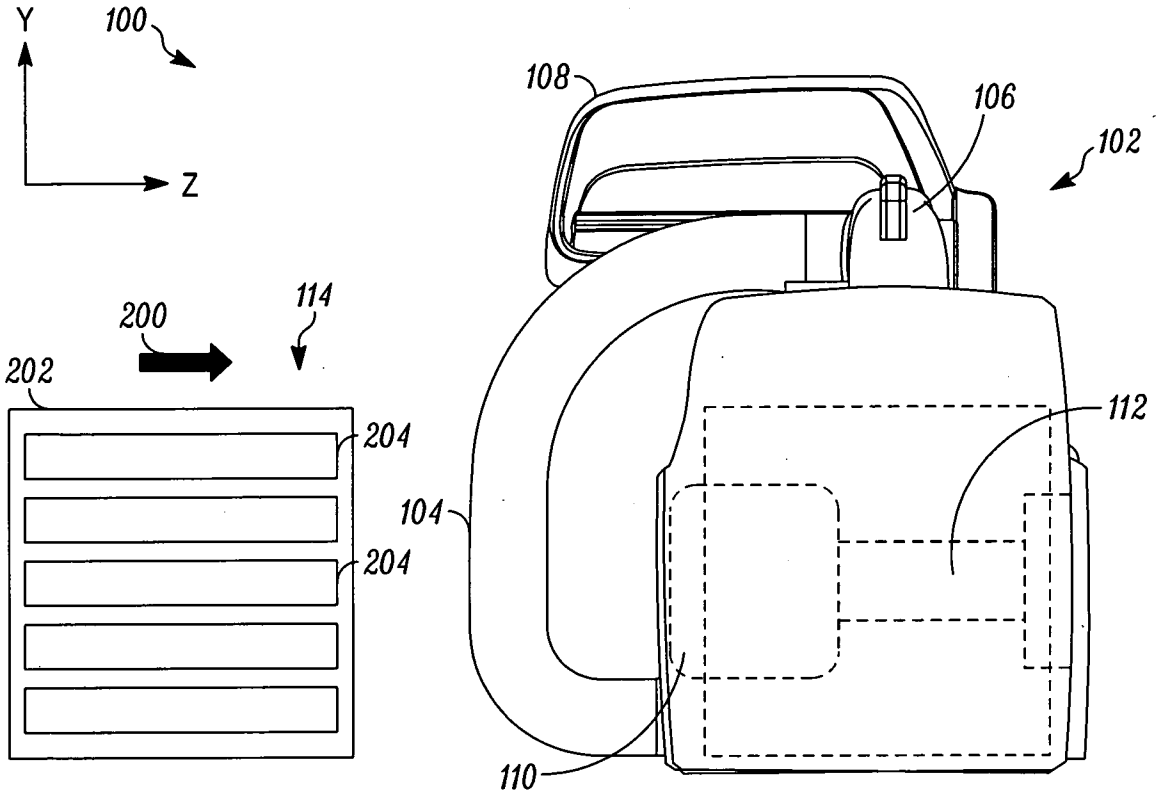

FIG. 2

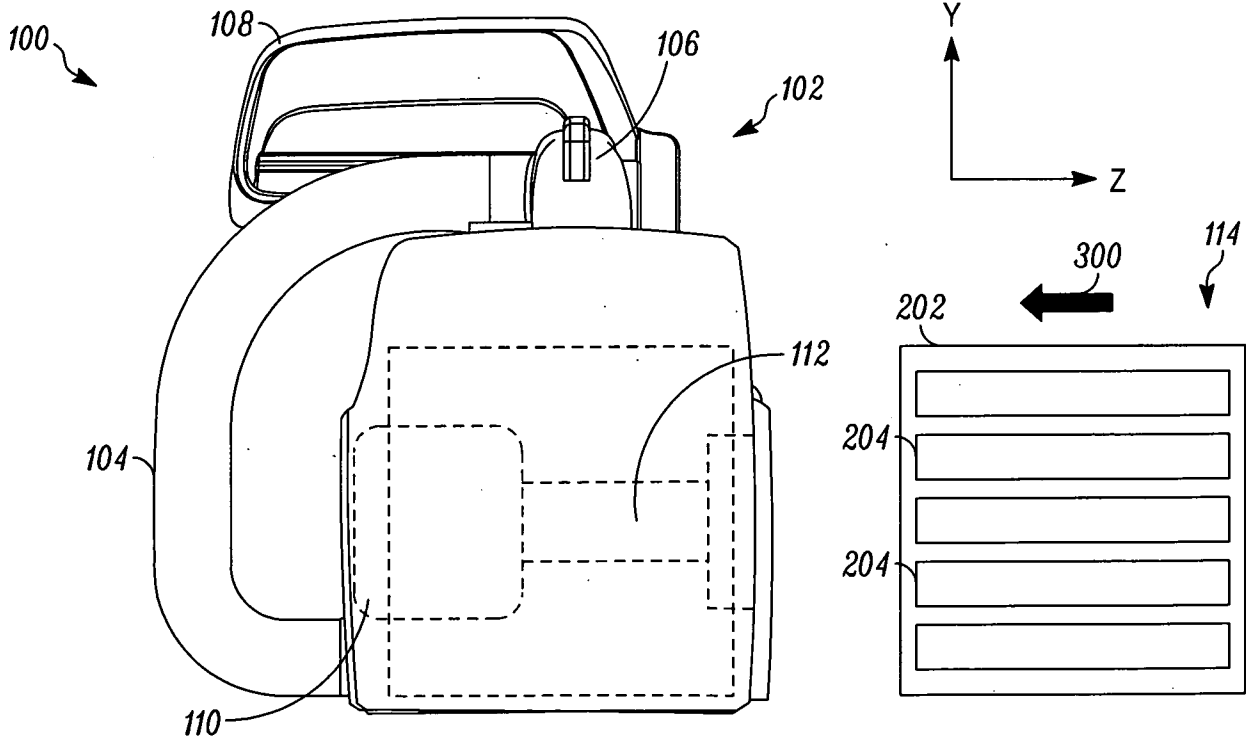

FIG. 3

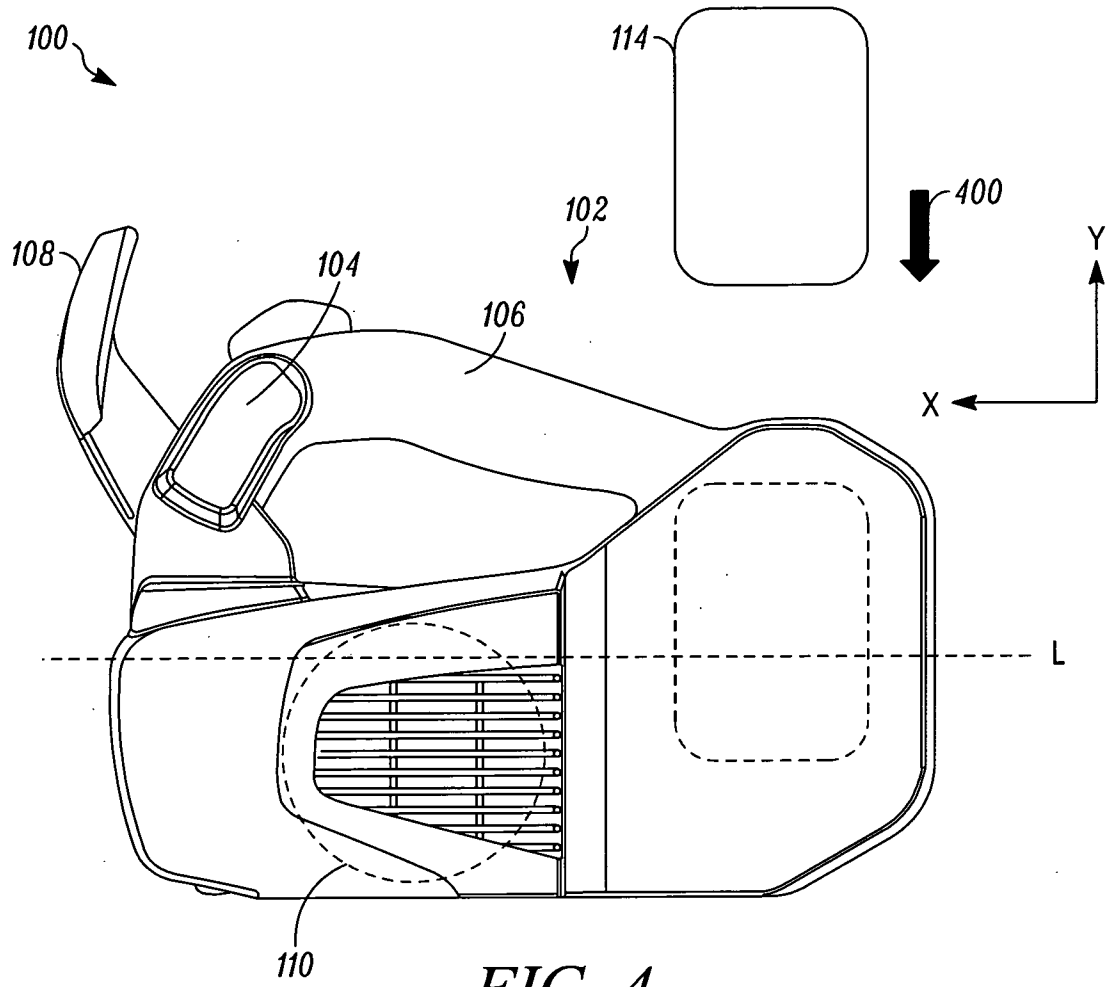

FIG. 4

4/6

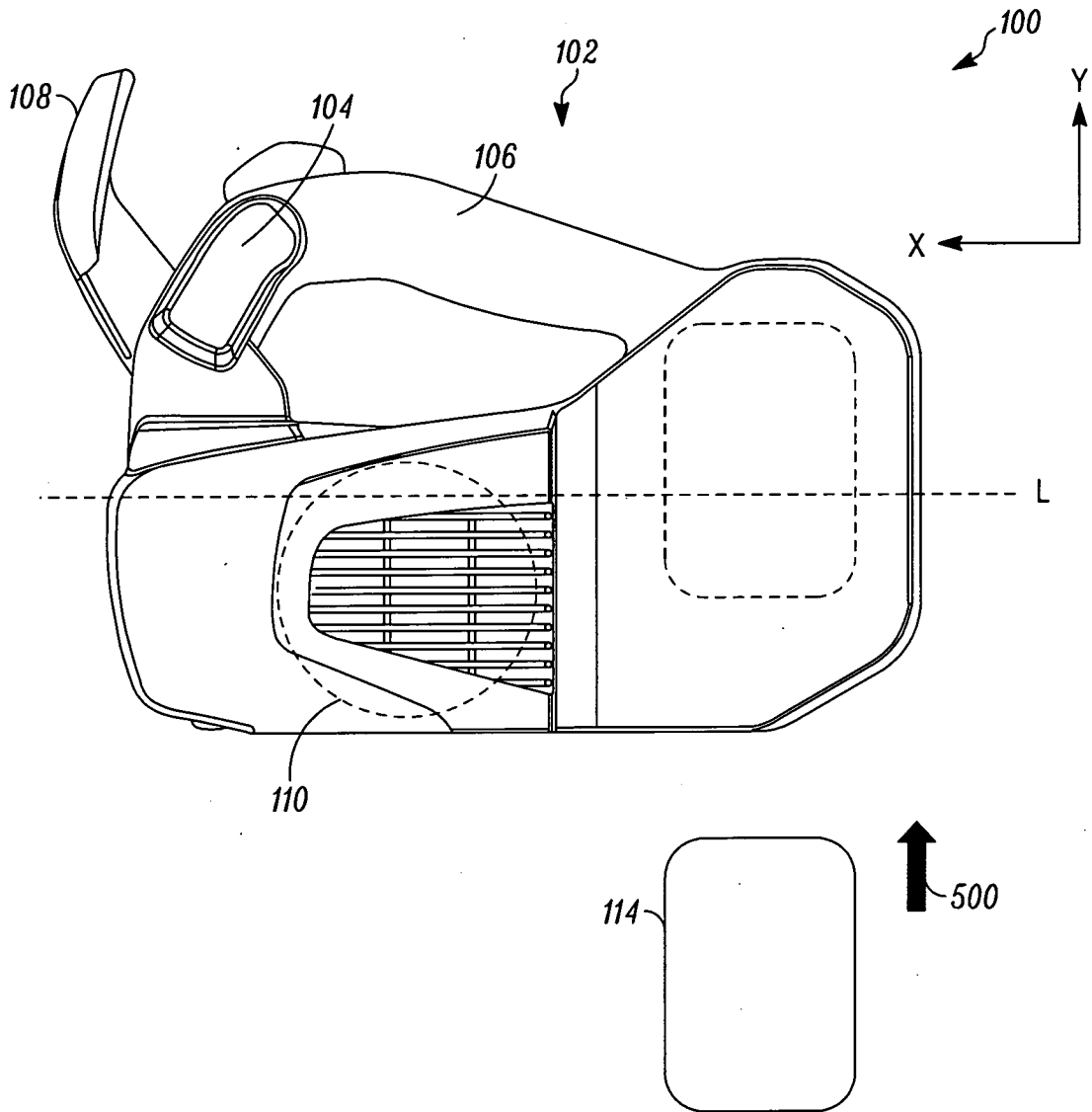
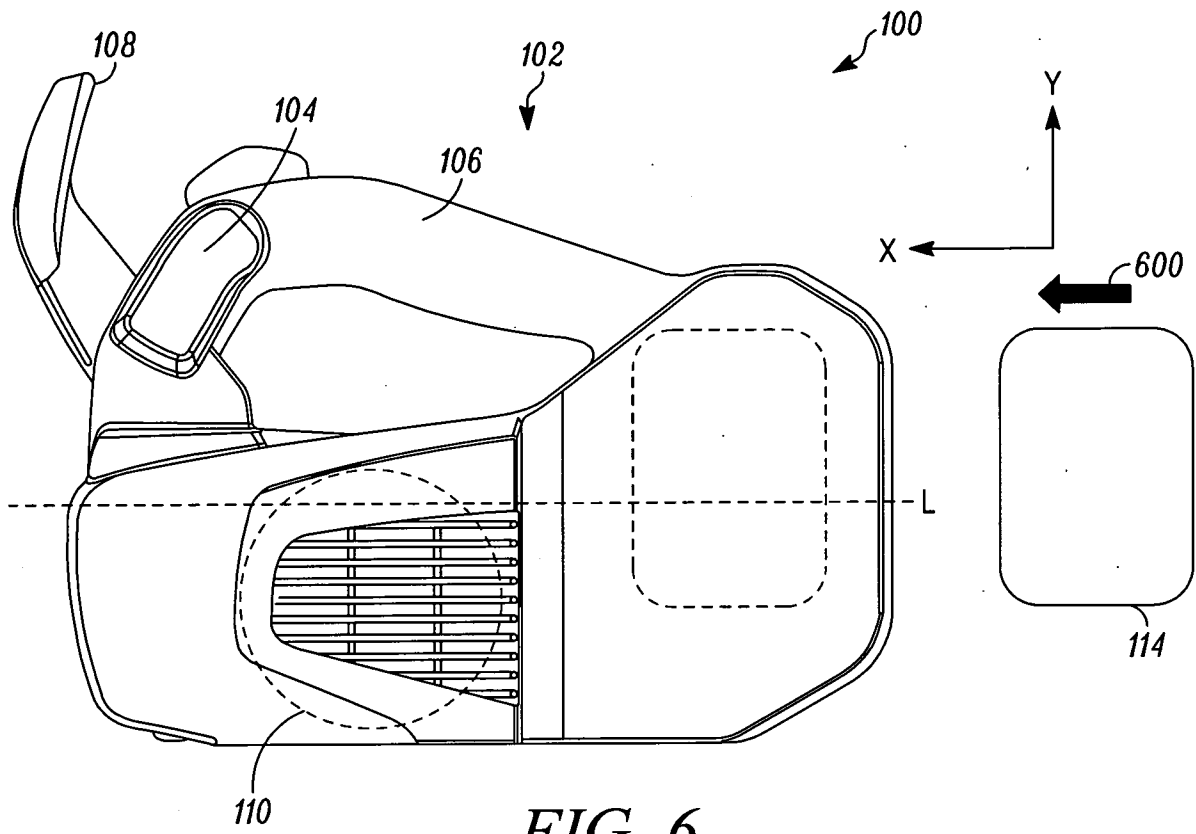

FIG. 5

5/6



6/6

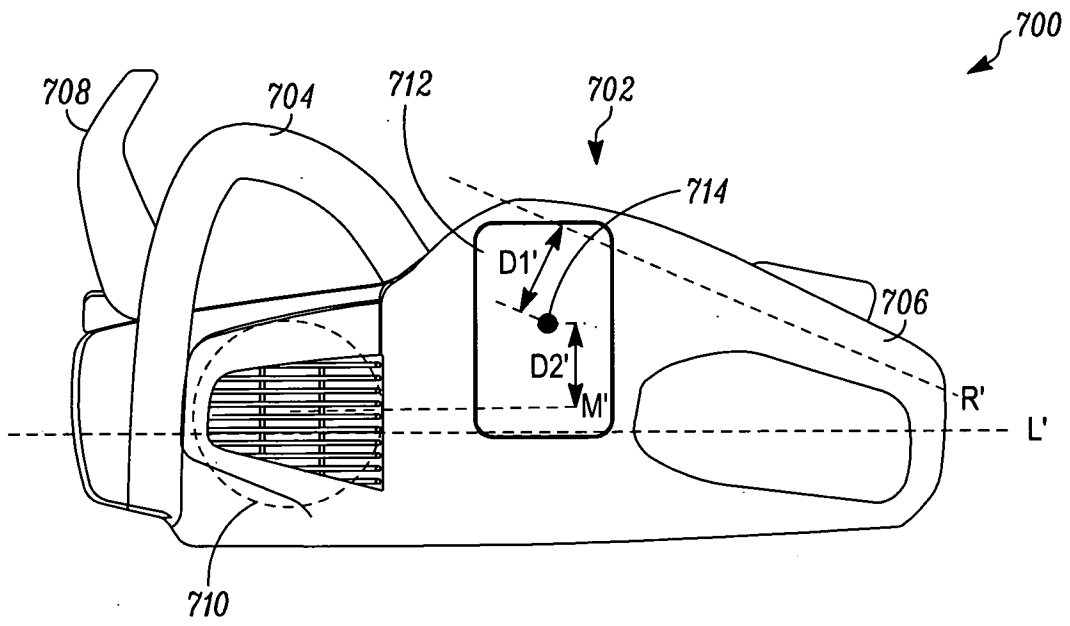

FIG. 7

INTERNATIONAL SEARCH REPORT

International application No
PCT/EP2010/001407

A. CLASSIFICATION OF SUBJECT MATTER
 INV. B25F5/02
 ADD.

According to International Patent Classification (IPC) or to both national classification and IPC

B. FIELDS SEARCHED

Minimum documentation searched (classification system followed by classification symbols)
 B25F

Documentation searched other than minimum documentation to the extent that such documents are included in the fields searched

Electronic data base consulted during the international search (name of data base and, where practical, search terms used)
 EPO-Internal

C. DOCUMENTS CONSIDERED TO BE RELEVANT		
Category*	Citation of document, with indication, where appropriate, of the relevant passages	Relevant to claim No.
X	GB 2 440 646 A (GMCA PTY LTD [AU]) 6 February 2008 (2008-02-06)	1-4, 7, 8, 10-13, 15
Y	page 7, paragraph 3-4 page 14, paragraph 5 - page 15, paragraph 2; figures 3a-4	5, 9, 14
X	US 5 685 080 A (AMANO KUNIO [JP] ET AL) 11 November 1997 (1997-11-11)	1-4, 6, 8, 10, 11, 13, 15
Y	column 2, lines 6-35; figures	5, 9, 14
X	DE 196 05 827 A1 (HITACHI KOKI KK [JP]) 29 August 1996 (1996-08-29)	1-4, 7, 8, 10-12
Y	column 10, line 61 - column 11, line 6; figures	5, 9, 14
	----- -/--	

Further documents are listed in the continuation of Box C. See patent family annex.

- * Special categories of cited documents :
- *A* document defining the general state of the art which is not considered to be of particular relevance
 - *E* earlier document but published on or after the international filing date
 - *L* document which may throw doubts on priority claim(s) or which is cited to establish the publication date of another citation or other special reason (as specified)
 - *O* document referring to an oral disclosure, use, exhibition or other means
 - *P* document published prior to the international filing date but later than the priority date claimed
 - *T* later document published after the international filing date or priority date and not in conflict with the application but cited to understand the principle or theory underlying the invention
 - *X* document of particular relevance; the claimed invention cannot be considered novel or cannot be considered to involve an inventive step when the document is taken alone
 - *Y* document of particular relevance; the claimed invention cannot be considered to involve an inventive step when the document is combined with one or more other such documents, such combination being obvious to a person skilled in the art.
 - *Z* document member of the same patent family

Date of the actual completion of the international search 26 November 2010	Date of mailing of the international search report 07/12/2010
--	---

Name and mailing address of the ISA/ European Patent Office, P.B. 5818 Patentlaan 2 NL - 2280 HV Rijswijk Tel. (+31-70) 340-2040, Fax: (+31-70) 340-3016	Authorized officer Flodström, Benny
--	---

INTERNATIONAL SEARCH REPORT

International application No

PCT/EP2010/001407

C(Continuation). DOCUMENTS CONSIDERED TO BE RELEVANT

Category*	Citation of document, with indication, where appropriate, of the relevant passages	Relevant to claim No.
Y A	CN 100 453 229 C (HOMELITE TECHNOLOGIES LTD [HK]) 21 January 2009 (2009-01-21) * abstract; figure 4	5,9 7,8,13, 15
Y A	----- EP 1 205 282 A2 (ILLINOIS TOOL WORKS [US]) 15 May 2002 (2002-05-15) figures 6,8	5 13
Y A	----- US 4 555 849 A (ANDO HIROYUKI [JP] ET AL) 3 December 1985 (1985-12-03) figure 2	9 10
Y A	----- US 2003/192191 A1 (WONG STEVE [HK] WONG STEVE [CN]) 16 October 2003 (2003-10-16) figures 17-19	14
E	----- EP 2 223 780 A2 (STIHL AG & CO KG ANDREAS [DE]) 1 September 2010 (2010-09-01) the whole document	1-5,7-9, 11,14,15

INTERNATIONAL SEARCH REPORT

Information on patent family members

International application No

PCT/EP2010/001407

Patent document cited in search report		Publication date	Patent family member(s)	Publication date
GB 2440646	A	06-02-2008	NONE	
US 5685080	A	11-11-1997	DE 19617157 A1	30-10-1997
DE 19605827	A1	29-08-1996	JP 3493645 B2 JP 8216046 A	03-02-2004 27-08-1996
CN 100453229	C	21-01-2009	CN 1636661 A	13-07-2005
EP 1205282	A2	15-05-2002	AT 383228 T AU 755116 B2 AU 8361001 A CA 2359791 A1 DE 60132284 T2 DK 1205282 T3 ES 2299469 T3 JP 2002219672 A JP 2008235282 A MX PA01011584 A NO 20015550 A NZ 515080 A	15-01-2008 05-12-2002 16-05-2002 14-05-2002 24-12-2008 19-05-2008 01-06-2008 06-08-2002 02-10-2008 07-06-2002 15-05-2002 30-06-2003
US 4555849	A	03-12-1985	DE 3318507 A1 JP 2045561 B JP 58222802 A	22-12-1983 11-10-1990 24-12-1983
US 2003192191	A1	16-10-2003	NONE	
EP 2223780	A2	01-09-2010	CN 101829981 A DE 102009012175 A1 JP 2010201612 A US 2010218967 A1	15-09-2010 02-09-2010 16-09-2010 02-09-2010