

Jan. 2, 1923.

1,440,646

E. G. SWANSON.
BOLT AND NUT ASSEMBLING MACHINE.
FILED SEPT. 9, 1921.

3 SHEETS-SHEET 1

Fig. 1.

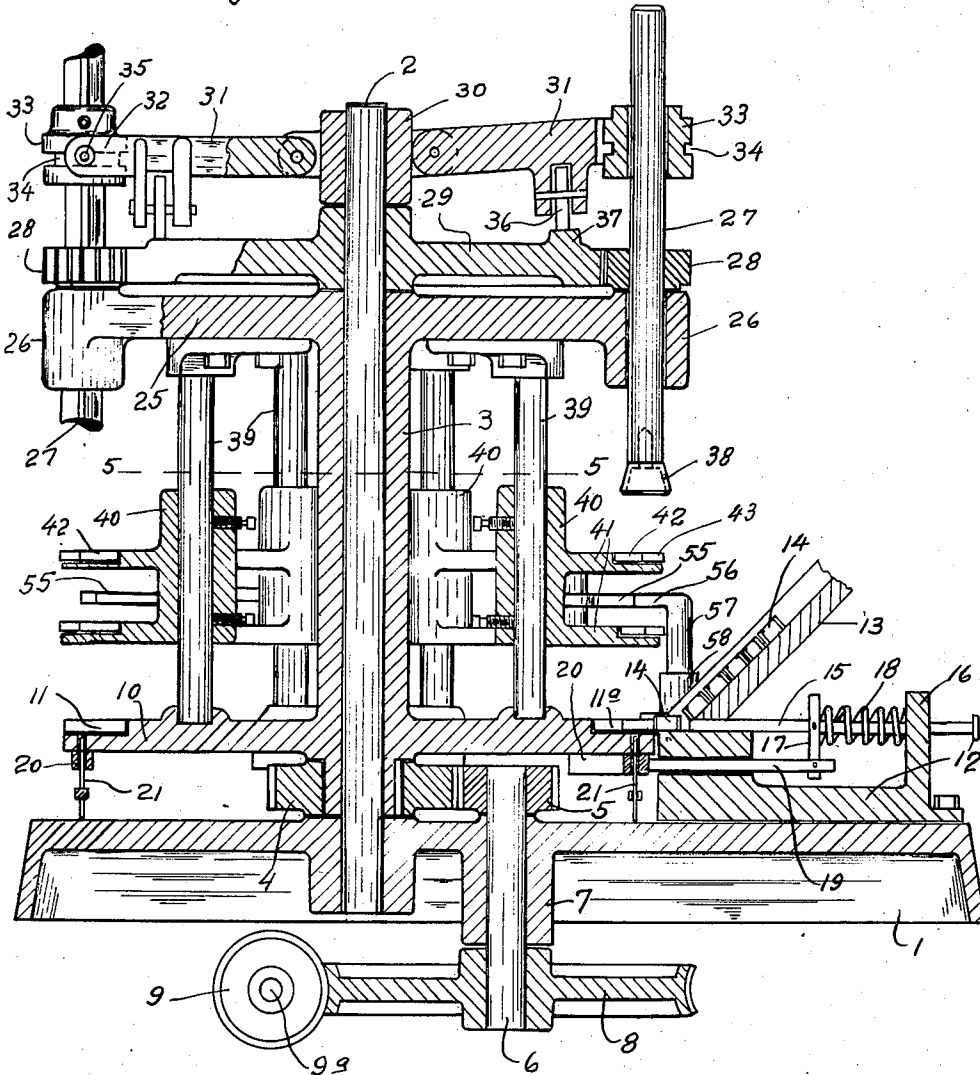
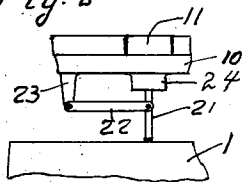

Fig. 2.



INVENTOR.
Emil Gilbert Swanson,
BY Walter N. Haskell,
his ATTORNEY.

Jan. 2, 1923.

1,440,646

E. G. SWANSON.
BOLT AND NUT ASSEMBLING MACHINE.
FILED SEPT. 9, 1921.

3 SHEETS-SHEET 3

Fig. 5

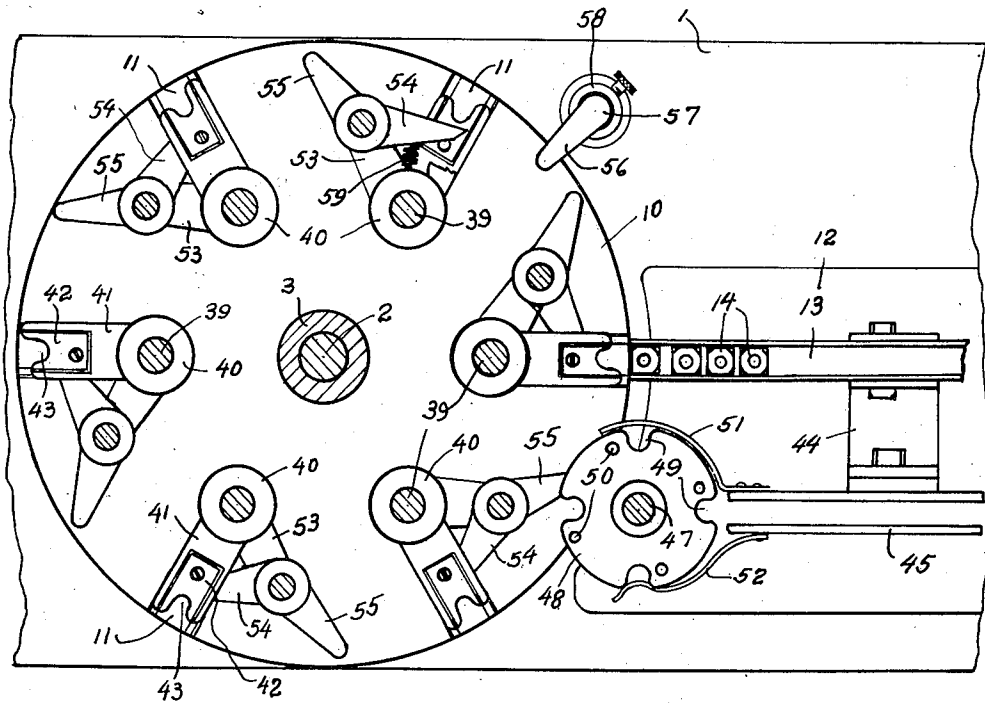

INVENTOR.
Emil Gilbert Swanson
BY *Walter N. Haskell*
his ATTORNEY

Patented Jan. 2, 1923.

1,440,646

UNITED STATES PATENT OFFICE.

EMIL GILBERT SWANSON, OF MOLINE, ILLINOIS.

BOLT AND NUT ASSEMBLING MACHINE.

Application filed September 9, 1921. Serial No. 499,590.

To all whom it may concern:

Be it known that I, EMIL GILBERT SWANSON, a citizen of the United States, residing at Moline, in the county of Rock Island and State of Illinois, have invented certain new and useful Improvements in Bolt and Nut Assembling Machines, of which the following is a specification.

My invention pertains to bolt and nut assembling machines, by the operation of which the nuts are automatically seated on the threaded ends of the bolts, the nuts being fed continuously from one source of supply, and the bolts from another source of supply, to a common point in the machine for assembly.

The chief purpose of the present invention is to provide a simple and efficient means for handling the nuts and bolts, and seating the nuts fully on the ends of the bolts, so as to preclude accidental release from the bolt. The arrangement of the machine is such that the bolts and nuts have a progressive movement while they are being assembled, so that the operation is being performed with several of such articles at the same time. By this means considerable time is saved.

The particular construction, arrangement, and operation of the various parts of the invention will be more fully understood from the following specification, reference being had to the drawings accompanying the same, in which:

Fig. 1 is a vertical medial section through the main part of the machine.

Fig. 2 is a detail of one of the nut-centering devices.

Fig. 3 is a plan view of the main operating mechanism.

Fig. 4 is a detail of the bolt feeding devices, with some parts of the machine in section.

Fig. 5 is a horizontal section on the line 5-5 of Fig. 1.

Similar parts are indicated by corresponding reference characters throughout the several figures.

1 represents a stationary table, and 2 a vertical shaft fixed therein. Rotatably mounted on the shaft 2 is a sleeve 3, to the lower end of which is fixed a gear-wheel 4, driven by a pinion 5 on the upper end of a shaft 6, journaled in a bearing 7 on the lower face of the table 1. Power may be applied to the shaft 6 in any known manner,

as by means of a worm-gear 8 on said shaft, actuated by a worm 9 on a shaft 9^a, to which movement is imparted. By this latter arrangement the movement of the shaft 6 is comparatively slow, and by forming the wheel 4 with a greater diameter than that of the wheel 5, the movement of such wheel and the sleeve 3 is still more reduced.

At its lower end the sleeve 3 is provided with a table 10 of circular form, in the outer edge of which, at regular intervals, are recesses 11, of suitable size to receive the nuts which are to be assembled. At one side of the table 10 is fixed to the table 1 a block 12, upon which is supported a nut chute 13, in inclined position, so as to provide a gravity feed for the nuts, shown at 14. The discharge end of the chute is in close proximity to the edge of the table 10, so that the nuts can be fed therefrom, in succession, into the recesses 11. This is accomplished by means of a plunger 15, slidably mounted in a bearing 16 on the plate 12, and provided with a cross-arm 17, between which and the bearing 16 is an extensible coiled spring 18, exerting a force upon the plunger 15 to move the same inwardly. Said plunger is held normally in an outward position by means of a rod 19, fixed to the arm 17, and in contact at its inner end with a cam 20 on the lower face of the table 10. As the table is turned so as to bring one of the recesses 11 opposite to the end of the chute 13, the rod 19 passes the end of the cam, permitting such rod and the plunger to move inwardly, the plunger carrying one of the nuts into position on the table. The recesses are formed of greater length than is required for the nut, and are provided at their inner ends with adjustment blocks 11^a, the size of which may be varied to accommodate nuts of different sizes. Said blocks also assist in properly positioning the nut to receive the companion bolt, which is fed downwardly from a point above the nut, when in position to receive the same.

The nuts are further centered by means of pins 21, vertically movable in perforations in the floors of the recesses 11, and in the cams 20. The pins are held in operative position by means of links 22, pivoted at one end to said pins and at the other end to posts 23 on the lower face of the table 10. At one point in their rotation the pins are forced upwardly by a cam 24 (Fig. 4), causing the upper end of the pin to enter the

opening in the nut in the recess immediately above the same, and adjust the position of the nut, to receive the end of a bolt.

On the upper end of the sleeve 3 is a table 5 25, on the outer edge of which is a series of bearings 26, in which are mounted spindles 27 so as to be vertically movable in such bearings, and also freely rotatable therein. Having a feathered connection with each of 10 the spindles 27 is a pinion 28, in mesh with the teeth of a gear-disk 29, fixed to the shaft 2. The pinions and spindles are thus rotatable together, at the same time permitting a vertical movement of the spindles within 15 said pinions.

Rotatable upon the upper end of the shaft 2 is a hub 30, pivotally connected with which are radial arms 31, fitted at their outer ends with yokes 32 partially encircling collars 33 20 fixed on the upper ends of the spindles 27, such collars having annular channels 34 engaged by pins 35 in the yokes 32. On their lower faces the arms 31 are fitted with rollers 36, which pass over a cam-track 37 on 25 the upper face of the disk 29. This results in a raising and lowering of the spindles 27 in one part of their progress. At their lower ends the spindles 27 are provided with sockets 38, adapted to receive the head of a 30 bolt, and turn the same upon the spindle being properly rotated. The positioning of the bearings 26 is such that the spindles are in alignment with the recesses 11, vertically. The spindles are held in the collars 33 so as 35 to be capable of adjustment therein, as by a set-screw, whereby the position of such spindles with relation to the table 10 can be varied to allow for bolts of greater or less length.

Upon the sleeve 3 being properly rotated, 40 the tables 10 and 25 will be carried round therewith, the pinions 28 having a planetary movement with relation to the disk 29, which is stationary. A rotary movement is thus 45 imparted to the pinions 28 and spindles 27, sufficient to give approximately six turns to the spindles in a complete rotation of the tables.

Secured at their ends to the tables 10 and 50 25, are posts 39, to which are secured sleeves 40, so as to be capable of vertical adjustment thereon, each of said sleeves carrying a pair of spaced-apart arms 41, in the outer ends of which are secured dies 42, provided with 55 bolt-receiving recesses 43. Mounted on the block 12 is a support 44, secured to which is a bolt-chute 45, adapted for the gravity feed of a succession of bolts, as shown at 46, such bolts being fed into the chute in any desired 60 manner, as from a hopper. At a point between the discharge end of the bolt chute and the table 10 is a post 47, fixed to the plate 12, and on the upper end of said post is mounted a pair of spaced-apart disks 48, 65 so as to be rotatable thereon. Said disks are

provided in their edges with recesses 49, into which the bolts are fed one at a time, and are then delivered to the arms 41 by the rotation of the disks. This is accomplished by means of pins 50, uniting said disks, and 70 which pins are engaged by the forward ends of the arms 41 in the rotation of the table 10. As shown in the drawings the disks 48 are shown provided with four of the recesses 49 and the movement of each of the arms 41 75 will give to said disks a quarter turn, so that by each of such movements one of the bolts will be advanced into the machine, in position to be threaded into the opening in one of the nuts 14 immediately beneath the same. 80 This is accomplished in the manner hereinbefore described, by the rotation of the spindle which is immediately above such bolt, and which is fed downwardly to engage the head of the bolt. After the desired number 85 of revolutions have been given to the bolt, the spindle is elevated again, and the bolt, with the nut in place thereon, is ejected from the machine.

To prevent accidental release of the bolts 90 while being fed into the machine, there is fixed to the chute 45 a curved guide 51, in a plane just above that of the upper disk 48, the heads of the bolts riding on said guide, and being supported thereby until 95 engaged by the end of the spindle 27. To prevent a too rapid movement of the disks 48 a spring 52 is provided, fixed at one end to one side of the chute 45, and having a curved portion adapted to enter the recesses 100 49, and hold the disks from movement, except when acted upon by the arms 41.

The ejection of the bolts from the machine is rendered certain by the following means:—Projecting from each of the sleeves 105 40 is a bracket 53, pivotally supported on which is an arm 54, provided with a trip 55, adapted for engagement with a projection 56 on the upper end of a post 57, vertically adjustable in a socket 58 on the 110 table 1. The contact of the trip 55 with the projection operates to move the arm 54, which is normally just in rear of one of the bolts, outwardly, forcing the bolt from its position in the arms 41. The bracket 115 53 being vertically movable with the sleeve 40, results in a change of position of the arm 54 at times, requiring a change in the vertical position of the projection 56 to conform thereto. The arms 54 are held 120 normally in an inactive position by means of coiled springs 59 connecting said arms with the sleeves 40.

To recapitulate:—When the machine has been set in motion, the operation thereof is 125 continuous, a constant feed of the nuts and bolts being provided in parallel movement at one side of the machine, such nuts and bolts being then arranged in pairs for assembling, and the assembling operation be- 130

ing carried on with several of said pairs at the same time, after which the assembled articles are discharged from the machine.

What I claim, and desire to secure by Letters Patent, is:

1. A device of the class described, comprising a bed-plate; a pair of spaced-apart tables rotatably mounted thereon, one of said tables being provided with a series of nut-receiving means; a series of bolt-rotating devices mounted in the other table in vertical alignment with the nut-receiving means; means for imparting rotation to said bolt-rotating devices; means for raising and lowering said bolt-rotating devices while being rotated; means for feeding a plurality of bolts, in succession, to said bolt-rotating devices; and means for feeding a plurality of nuts, in succession, to said nut receiving means.

2. A device of the class described, comprising a bed-plate; a pair of spaced-apart tables supported thereon, so as to be capable of simultaneous rotation, one of said tables being provided with nut-receiving recesses; a series of spindles rotatably mounted in the other table in vertical alignment with said nut-receiving recesses, and provided with means for engagement with the head of a bolt; means for raising and lowering said spindles at a given point in the rotation of said tables; means for delivering a succession of bolts, in position to be engaged by said spindles; means for delivering a succession of nuts, in position to be received by said recesses; and means for causing said nuts to consecutively enter said recesses.

3. A device of the class described, comprising a bed-plate; a pair of tables mounted thereon, so as to rotate together, one of said tables being provided at its edge with nut receiving recesses; means for properly positioning the nuts in said recesses, in position to receive the end of a bolt; a series of spindles rotatably mounted in the other table, in vertical alignment with said recesses, and provided with bolt engaging means at one of their ends; means for rotating said spindles coincidently with the rotation of said tables; means for raising and lowering said spindles at a given point in the rotation of said tables; means for delivering a succession of bolts into said machine; means for conveying said bolts successively, into a position to be engaged by said spindles; and means for feeding a plurality of nuts, in succession, to said nut-receiving recesses.

4. A device of the class described, comprising a bed-plate; a pair of spaced-apart tables mounted thereon, so as to rotate together, the lower one of said tables being provided with a series of nut receiving openings; a series of spindles rotatably mounted in the upper table, in vertical alignment

with said openings; means for rotating said spindles coincidently with the movement of said tables; means for feeding a plurality of bolts into said machine, in position to be engaged by said spindles; means for feeding a plurality of nuts into said openings, in succession; and means for discharging the assembled bolts and nuts from the machine.

5. A device of the class described, comprising a bed-plate; a pair of spaced-apart tables mounted thereon, so as to be capable of simultaneous rotation; one of said tables being fitted with nut-receiving openings; a series of spindles rotatably mounted in the other table; means for imparting to said spindles a number of rotary movements for each rotation of said tables; means for raising and lowering said spindles at a point near the end of said movements; means for feeding a plurality of nuts consecutively into said openings; means for feeding into said machine a plurality of bolts, in position to be received by said spindles and turned into said nuts; and means for discharging the assembled nuts and bolts from the machine at the end of said rotary movements of the spindles.

6. A machine of the class described, comprising a bed-plate; a vertical post fixed therein; a pair of tables rotatably mounted on said post, one of said tables being fitted with a series of nut-receiving openings; a series of spindles rotatably mounted in the other of said tables, in vertical alignment with said openings, and adapted for engagement with the head of a bolt; a gear-disk fixed to said post; pinions on said spindles, in mesh with said gear-disk, and permitting free vertical play of the spindles; collars on the upper ends of said spindles; a hub loosely mounted on said vertical shaft; arms pivotally connected with said hub and provided with yokes in engagement with said collars; and means for consecutively raising and lowering said arms at one point in the rotation of said tables.

7. In a device of the class described, a table rotatably mounted; a series of spindles rotatably mounted in said table and provided with bolt engaging means; means for imparting to said spindles a number of rotations in each revolution of said table; bolt-receiving devices movable with said table, and adapted to receive a bolt in position to be engaged by said spindles; a bolt-chute adapted to convey a succession of bolts to a point in proximity to said bolt-receiving devices; and means for delivering said bolts, consecutively, to said bolt-receiving devices.

8. In a device of the class described, a table rotatably mounted; a series of spindles rotatably mounted in said table and provided with bolt-engaging means; means for imparting to said spindles a series of rotations in each revolution of said table; means for

raising and lowering said spindles at the end of one series of rotations and commencement of another one thereof; bolt-receiving arms movable with said table, adapted to receive a bolt in position to be engaged by said spindles; a bolt-chute adapted to convey a succession of bolts to a point in proximity to said bolt receiving arms; and bolt conveying disks, adapted for rotation by said arms, capable of receiving said bolts and conveying them, one at a time, to said bolt receiving arms.

9. A machine of the class described, comprising a bed-plate; a pair of spaced-apart tables mounted thereon so as to be capable of simultaneous rotation, one of said tables being fitted with a series of nut-receiving openings; a series of spindles rotatably mounted

in the other table, in alignment with said openings; means for imparting to said spindles a number of rotations for each revolution of said tables; bolt-receiving arms movable with said tables, each adapted to receive a bolt in position to be engaged by said spindles; bolt-conveying disks capable of receiving a succession of bolts and delivering them, consecutively to said arms; means for feeding a plurality of bolts to said disks, in succession; means for actuating said disks coincident with the movement of said arms; a guide for said bolts while being conveyed by said disks, and means for holding said disks yieldably, at the end of each partial rotation thereof.

In testimony whereof I affix my signature.
EMIL GILBERT SWANSON.