

19



Europäisches Patentamt
 European Patent Office
 Office européen des brevets



11 Publication number:

0 653 553 A2

12

EUROPEAN PATENT APPLICATION

21 Application number: **95101307.7**

51 Int. Cl.⁶: **F01P 3/02, F02F 1/36, F02F 7/00**

22 Date of filing: **27.06.90**

This application was filed on 31 - 01 - 1995 as a divisional application to the application mentioned under INID code 60.

30 Priority: **19.07.89 JP 186614/89**
06.07.89 JP 174675/89
19.07.89 JP 186616/89
06.07.89 JP 174676/89

43 Date of publication of application: **17.05.95 Bulletin 95/20**

60 Publication number of the earlier application in accordance with Art.76 EPC: **0 560 402**

84 Designated Contracting States: **DE FR GB**

71 Applicant: **YAMAHA HATSUDOKI KABUSHIKI**

KAISHA
2500 Shingai
Iwata-shi
Shizuoka-ken, 438 (JP)

72 Inventor: **Okui, Kaoru**
161-158 Toshin-cho
Iwata-shi,
Shizuoka-ken 438 (JP)
 Inventor: **Kobayashi, Manabu**
4-1-3 Fujimi-cho
Iwata-shi,
Shizuoka-ken 438 (JP)

74 Representative: **Patentanwälte Grünecker, Kinkeldey, Stockmair, Aufenanger & Partner**
Maximilianstrasse 58
D-80538 München (DE)

54 **Cooling system for an internal combustion engine.**

57 The present invention relates to a cooling system for an internal combustion engine comprising a cylinder head affixed to a cylinder block defining a plurality of cylinders and a cylinder head coolant jacket for circulating coolant between an intake and exhaust side of the cylinder head, said cylinder head having at least one intake passage extending through one side of said cylinder head and at least one exhaust passage extending through another side of said cylinder head. The cooling system is improved in that a flow regulating member is provided in the cylinder head coolant jacket between adjacent cylinders for regulating a transverse flow of coolant through the cylinder head jacket between the intake and exhaust sides. According to another aspect of the invention, the cylinder head coolant jacket is communicated with the cylinder block coolant jacket for circulating the coolant therethrough after cooling the cylinder head, and a coolant main passage is formed along one side of the cylinder head for circulating the coolant through the cylinder head coolant jacket transversely from said one side to the

opposite side of the cylinder head.

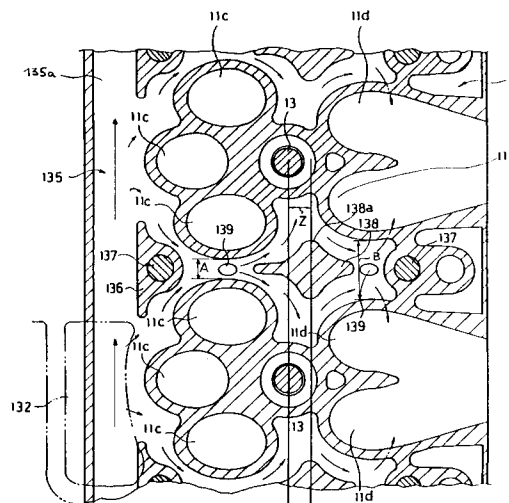

FIG. 13

EP 0 653 553 A2

The present invention relates to a cooling system for an internal combustion engine comprising a cylinder head affixed to a cylinder block and a cylinder head coolant jacket for circulating coolant through said cylinder head.

As it is well known, it is desirable to take care to lower preferably the temperature of the cylinder head enabling to increase the engine output by increasing the permissible combustion temperature. Of course, such a strategy requires improved and forced cooling of the cylinder head. Therefore, it has been deliberated to mount the water pump directly on the cylinder head, in particular to install it at one side of the engine, intending to supply cooling water to the cylinder head prior to supplying cooling water to the cylinder block cooling structure. However, under said design aspects, the internal combustion engine tends to become bulky because the side face of the cylinder head in a crankshaft direction is provided with intake and exhaust pipes and any location of the water pump at the cylinder head requires to avoid interference with these pipes.

In order to provide a compact cooling structure, it has already been proposed, to connect the delivery port of a coolant pump with a coolant jacket for the cylinder block. The cylinder block coolant jacket is communicated with the cylinder head coolant jacket via passages integrally formed in the cylinder block and the cylinder head, respectively, so that the coolant which is introduced into the cylinder block coolant jacket from the discharge side of the pump and circulated through said cylinder block coolant jacket, flows into the cylinder head coolant jacket after cooling the cylinder block and is then circulated in said cylinder head coolant jacket.

US-4 699 092 shows a coolant jacket arrangement of a cylinder head, wherein an annular coolant chamber is associated with each cylinder formed in the cylinder block and the cylinder head. The coolant is introduced into the cylinder head coolant jacket through inlet orifices formed in the bottom portion of the cylinder head and connected to the cylinder block coolant jacket, and flows through said coolant chamber towards the uppermost portion thereof, where a discharge passage emanates from.

Aside from the fact that this known cooling arrangement cannot provide forced cooling of the cylinder head, as it cools first the cylinder block, it is not satisfactory regarding the flowing direction and regulation of the flowing speed of the coolant circulating through the cylinder head coolant jacket.

It is therefore an objective of the present invention to provide an improved cooling system for an internal combustion engine, which system enables an improved cooling of the cylinder head structure

and compensates the increased temperature load caused by the combustion process occurring in the combustion chamber defined by the cylinder head structure.

5 According to the present invention, this objective is performed in that a flow regulating member is provided in the cylinder head coolant jacket between adjacent cylinders for regulating a transverse flow of coolant through the cylinder head jacket between the intake and exhaust sides there-
10 of.

15 Since the temperature load on the cylinder head structure usually differs between the intake side and the exhaust side thereof, the coolant flows transversely through the coolant jacket between the intake and exhaust side and the regulating member is arranged in said transverse flow so that the coolant may flow with a prescribed speed, enabling a very efficient and high precision cooling of the
20 cylinder head structure.

25 According to another aspect of the invention, said objective is performed in that the cylinder head coolant jacket is communicated with a cylinder block coolant jacket for circulating the coolant therethrough after cooling the cylinder head and a coolant main passage is formed along one side of the cylinder head for circulating the coolant through the cylinder head coolant jacket transversely from said one side to the opposite side of the cylinder
30 head.

35 Accordingly, the coolant flows transversely through the coolant jacket of the cylinder head so as to provide an increased cooling of the cylinder head and flows then into the cylinder block coolant jacket and is circulated therethrough so as to cool the cylinder block after cooling the cylinder head.

40 According to a preferred embodiment of the present invention, the cylinder head coolant jacket forms a first passage between adjacent cylinders on the intake side of the cylinder head and a second passage on the exhaust side of the cylinder head between said adjacent cylinders, the width of said first passage being smaller than the width of said second passage.

45 Thus, the volume of the coolant surrounding the hot exhaust passages is larger than on the intake side and the speed of the coolant flowing on the exhaust side is decreased in comparison with the intake side, so that effective cooling of the exhaust side, whose temperature is apt to be higher, is achieved.

50 Further preferred embodiments of the invention are laid down in the further subclaims.

55 Hereinafter the present invention is illustrated and explained in greater detail by means of a preferred embodiment and accompanying drawings, wherein:

Figure 1 is a side view showing the assembled state of an automotive internal combustion engine according to the present invention,

Figure 2 is a plan view for Figure 1,

Figure 3 is a side view of the internal combustion engine shown in Figure 1,

Figure 4 is a front view of the internal combustion engine of Figure 3,

Figures 5 and 6 are partially broken-away side views of the internal combustion engine of Figure 1,

Figure 7 is a sectional view along the line VII-VII in Figure 6,

Figure 8 is a sectional view along the line VII-VII in Figure 5,

Figure 9 is a plan view of the cylinder block of the internal combustion engine according to Figure 1,

Figure 10 is an arrow view along the arrow mark 1 in Figure 9,

Figure 11 is a sectional view along the line XI-XI in Figure 10,

Figure 12 is a vertical sectional view of the cylinder head of the internal combustion engine of Figure 1,

Figure 13 is a sectional view along the line XIII-XIII in Figure 12,

Figure 14 is a side view of the cylinder head of the internal combustion engine according to the present invention on the side opposite to that on which a second drive chain is provided, and

Figure 15 is a system diagram of the cooling system of the internal combustion engine according to the present invention.

In Figures 1 and 2, the reference number 1 denotes the engine compartment of an automobile formed above and between the right and left front wheels 3 connected through front wheel shafts 2. Within this engine compartment 1 is mounted an engine unit 4 having a 4-stroke 6-cylinder internal combustion engine with its radiator 5 arranged in front of this engine unit 4. The engine unit 4 is disposed with its crankshaft 6 extending laterally of the vehicle so that the passenger compartment may be spacious.

The crankshaft 6 of the engine unit is journaled between the cylinder block 7 and the bearing case 8 as shown in Figs. 5 to 7, and is connected with each piston 9 provided in the respective cylinder through the respective connecting rod 10. As shown in Figs. 3 and 7 in double-dotted chain lines, a disk 90 having projections 90a mounted on its periphery is provided on one end of the crankshaft 6 projecting out of the cylinder block 7 to detect the phase of the crankshaft rotation by sensing the passing of the projection 90a mounted on the disk 90 by a crank sensor 91 mounted on the cylinder block 7.

On the cylinder block 7 is mounted a cylinder head 11 constituting the engine E, on which head 11 is provided a head cover 12, and each cylinder is provided with an ignition plug 13.

The bearing case 8 is provided with an oil pan 14 connected with an oil tank 15 which tank 15 is disposed forwardly of the vehicle from the bottom to the top of the engine through the entire height of the engine.

As shown in Figs. 5 and 6, the cylinder bank of the engine is inclined from the verticality backward of the vehicle. The power takeout shaft 16 for taking out the output power of the crankshaft 6 is disposed in parallel with the crankshaft 6 and further is disposed slantly forwardly above the crankshaft 6. The oil tank 15 reserving engine oil is located slantly forwardly under the crankshaft 6 and the power output shaft 16 and is thus faced forwardly of the vehicle as shown by the arrow mark FWD in Figs. 3, 4 and 6. The power takeout shaft 16 is positioned in such a manner that the angle formed between the cylinder axis plane L1 and the plane L2 including both of the crankshaft 6 axis and the power output shaft 16 axis may be an acute angle.

The oil pan 14 has a pair of oil passages 17 formed vertically through both sides of the guide portion 14a as shown in Fig. 6, and the engine oil collected in the oil pan 14 is sucked in through the inlet port 17a at the bottom of the oil passage 17 and is sent to the oil tank 15 by discharge pumps 18 and 19 mounted on the power takeout shaft 16. The oil pan 14 and the oil tank 15 is partitioned by a wall provided with oil passages 17. The oil which has lubricated various portions of the engine is collected at the bottom of the crank chamber A formed with the cylinder block 7, bearing case 8 and oil pan 14, and the inlet port 17a is provided with a net 20 so that dust may not be sucked in. Inside the oil pan 14 is mounted a plate 21 on the guide portion 14a.

The oil reserved in the tank 15 is sucked through a strainer 25 and a pipe 26 disposed at the bottom of the tank 15 and then is fed to various lubricating points in the engine by the oil pump 24 provided on the power output shaft 16 through an oil cooler 22 and an oil filter 23, then through an oil passage 14b formed through the oil pan 14 and an oil passage 8a formed through the bearing case, and further through oil passages 7a and 11a formed through the cylinder block 7 and the cylinder head 11, respectively.

This circulation of oil is shown by arrow marks in Fig. 6.

The oil tank 15 is provided, at its top, with an oil refill mouth 15a closed by a refill cap 27, and is further provided with a breather portion 15b by forming a labyrinth with partitions (not shown) within its top portion.

As shown in Figs. 7 and 8, the crankshaft 6 has a gear 28 formed around one of its crankarms, and this gear 28 is in engagement with the gear 29 mounted on the power takeout shaft 16.

Power transmission from the crankshaft 6 to the power takeout shaft 16 is not limited to through gears 28 and 29 as described above, but may be through a chain, and the gears or the chain may be arbitrarily positioned at one end of the crankshaft or midway of it.

The countershaft 31 is journaled on the cylinder head 11 on one side of the cylinder block 7, and the gear 30 provided on the power takeout shaft 16 is connected to the gear 32 on the countershaft 31 through a first chain 33, with a reduction ratio of, e.g., 0.8. Further, the gear 34 mounted on this countershaft 31 is connected to the gears 38 on the camshafts 37 for the valve operating mechanism 36 through a second chain 35 with a reduction ratio of, e.g., 0.6, so that the camshafts 37 may be rotated by the rotation of the crankshaft 6. The cams 39 formed integrally with the camshafts 37 are rotated together with the camshafts 37 and operate the intake and exhaust valves (not shown) to open/close the intake and exhaust passages 11c and 11d formed through the cylinder head 11 with predetermined timings. The camshafts 37 are rotatably journaled on the cylinder head 11 through a cam cap 102. Each intake passage 11c is provided with a fuel injector (not shown) to supply fuel with predetermined timings.

The countershaft 31 is journaled on the cylinder head 11 above the power takeout shaft 16 and under the intake passage 11c and an intake pipe 41 leading from this intake passage 11c. The first chain 33 is extended along the cylinder axes, and further, as shown in Figs. 8 through 10, is positioned between the cylinders X1 and X2 on one side of the cylinder X1. The second chain 35 is positioned on the other side of the cylinder X1 on one side of the engine.

The cylinder head 11 supporting the countershaft 31 has accommodation openings 112 and 113 formed for accommodating gears 32 and 34 both mounted on the countershaft 31, and covered by a cap 114 and a cover 116, respectively. The accommodation opening 112 on the side on which is connected the first chain 33 is opened slantly upward.

A drive shaft 121 for driving the water pump 120, positioned on the front side of the engine proper E, is journaled on the front side of the cylinder block 7 in parallel to the crankshaft 6 and the power output shaft 16, and the gear 122 provided on this drive shaft 121 is in engagement with the first chain 33 so that the drive shaft 122 may be rotated by and in connection with the crankshaft 6. Since the drive shaft 121 is on the same side of

the cylinder axis plane L1 with respect to the power takeout shaft 16 which is an indispensable component for taking out the output power of the crankshaft 6, the engine width laterally of the crankshaft will not be particularly increased by providing this drive shaft 121.

As shown in Figs. 8 and 11, the water pump 120 is positioned within the width of the engine proper E in the crankshaft direction. On the suction side of this water pump 121 is provided a water inlet fitting 123, which is connected to the outlet of the radiator 5 through a piping 124. As shown in Figs. 6 and 15, the water inlet fitting 123 is incorporated with a regulating valve 125 provided with a thermostat 126 for allowing the coolant water to flow into the water pump 120 when the temperature of the coolant water within the engine is over a predetermined limit.

The delivery port 129 on the delivery side of the water pump 120 is connected to the coolant water inlet 130 provided on the front (with respect to the vehicle) side of the cylinder block 7, and the coolant water is supplied to the coolant water passage 132 formed within the cylinder head 11 from this coolant water inlet 130 through a coolant water passage 131 formed within the cylinder block 7 around the drive shaft 121. This coolant water inlet 131 is required only to be positioned on the side faces forwardly of the vehicle, and it may be directed either laterally of the vehicle as in this embodiment or forwardly of the vehicle.

Since the water pump 120 is mounted on the cylinder block 7 in such a manner that the coolant water inlet 130 of the cylinder block 7 is covered by the delivery port 129 of the water pump 120, no piping is required to connect the coolant water inlet 130 to the delivery port 129. Further, since the coolant water passage 131 and the coolant water inlet 130 formed through the cylinder block 7 are formed through one side face of the bearing portion 133 swelling forwardly of the cylinder block 7, they require no particular swelling to be formed on the cylinder block 7, which will prevent the engine proper E from becoming bulky.

As shown in Figs. 9 and 11, the coolant water passage 131 formed through the cylinder block 7 is opened on the top end face of the cylinder block 7, and the coolant water passage 132 of the cylinder head 11 is opened on the bottom face of the cylinder head 11. The opening 131a of the coolant water passage 131 on the cylinder block side is opened opposite to the opening 132a of the coolant water passage 132 on the cylinder head side. Therefore, the coolant water passages 131 and 132 can be communicated with each other only by mounting the cylinder head 11 on the cylinder block 7.

The coolant water passage 131 does not join the water jacket 134 for the cylinder block 7 but is communicated with the coolant water passage 132 formed within the cylinder head 11, and through this coolant water passage 132 is led the coolant water to a main passage 135a of the water jacket 135 formed within the cylinder head 11. This flow of the coolant water is shown by arrow marks in Fig. 15.

Since the coolant water inlet 132a of the head water jacket 135 for the cylinder head 11 is opened at a height lower than the intake passage 11c and the intake pipe 41, and further since the coolant water passage 132 is formed integrally with the cylinder head 11, the coolant water passage 132 will not interfere with the intake passage 11c and the intake pipe 41, which facilitates arrangement of the coolant water passage.

Thus, since the water pump 120 is mounted on the cylinder block 7 and the coolant water is supplied to the head water jacket 135 for the cylinder head 11 through coolant water passages 131 and 132 provided independently of the block water jacket 134 as described above, although the cylinder head 11 is cooled prior to the cylinder block 7, the water pump 120 can be disposed without interfering with the intake pipe 41, exhaust pipe 40, etc., which makes it possible to obtain a compact engine unit.

Further, since the water pump 120 and the coolant water inlet 132a of the head water jacket 135 are positioned on the side faces, on the same side parallel to the crankshaft 6, of the cylinder block 7 and the cylinder head 11 respectively, the water pump 120 and the coolant water passage 131 will not overlap with each other longitudinally of the crankshaft 6, which makes it possible to shorten the engine unit longitudinally of the crankshaft 6.

The mounting seats 120a for the water pump 120, the coolant water inlet 132a of the head water jacket 135 and the coolant water inlet 130a of the coolant water passage 131 are required only to be positioned on the side faces, parallel to the crankshaft 6, of the cylinder head 11 or the cylinder block 7, and they are not necessarily to be opened perpendicularly to the crankshaft 6. In this embodiment, they are opened longitudinally of the crankshaft 6 or of the cylinder axis.

The coolant water passage 131 may be formed with a hose or the like separate from the cylinder block 7. Further, the water pump 120 and the coolant water passage 131 may be provided on the exhaust side.

As shown in Figs. 12 and 13, the cylinder head 11 is fastened on the cylinder block 7 through bolts 137 inserted through boss portion 136 between cylinders, is provided with intake passages 11c and

exhaust passages 11d formed on one and the other side of and above each combustion chamber, and is further provided with an ignition plug 13 fastened at the center of each combustion chamber.

The water jacket 135 for the cylinder head 11 is formed around the boss portions 136, intake passages 11c and exhaust passages 11d. Between these cylinders are provided flow regulating portions 138 in which are formed guide portions 138a to guide the coolant water so that the coolant water may flow with a prescribed speed to cool the cylinder head 11. These flow regulating portions 138 are positioned on the exhaust side effectively to cool the exhaust side whose temperature is apt to be higher than the intake side. Further, the guide portion 138a of the flow regulating portion 138 is positioned in such a manner that their tips are offset by a distance Z from ignition plugs 13 to the exhaust side to elevate the cooling effect by leading the coolant water toward the exhaust side of the ignition plugs 13. This flow of the coolant water within the cylinder head 11 is shown by arrow marks in Figs. 12 and 13.

Further, as shown in Fig. 6, the coolant water in the head water jacket 135 for the cylinder head 11 is supplied from the communicating passages 139 through the lower portion of the cylinder head 11 to the block water jacket 134 through communicating passages 139 formed through the cylinder block 7 to cool the cylinder block 7. Accordingly, the coolant water is first led to the cylinder head 11 to cool it whose temperature is apt to become higher due to engine operation, and then cools the cylinder block 7, so that the engine can be cooled effectively.

The coolant water outlet 140 communicated with the water jacket 134 formed within the cylinder block 7 is formed on the front side of the cylinder block 7 in the vicinity of the water pump 120. On this coolant water outlet 140 is fastened a water outlet fitting 127 which is communicated with the inlet side of the radiator 5 through a piping 141. The radiator 5 is provided with a fan switch 142. The inlet and the outlet of the radiator 5 are positioned symmetrically to each other to make the coolant flow across the radiator 5.

Accordingly, the coolant water flows as shown by arrow marks in Fig. 13. That is, while the engine is running and the coolant water temperature has reached a prescribed limit, the thermostat 126 in the regulating valve 125 works to intercept the bypass passage 128 while communicating the water inlet fitting 123 with the water pump 120 to send the coolant water from the radiator 5 to the cylinder head 11 and the cylinder block 7 by the water pump 120 through the water inlet fitting 123 to cool them. The coolant water after cooling the cylinder block 7 is returned to the radiator 5

through the water outlet fitting 127.

As shown in Fig. 15, this water outlet fitting 127 is provided with a water temperature sender 143 and a water temperature sensor 144. This water outlet fitting 127 provided on the water outlet 140 is communicated with the water inlet fitting 123 through a bypass passage 128 on the front side of the cylinder block 7, and, by mounting this water outlet fitting 127, water inlet fitting 123 and water pump 120 in parallel and close to one another, the bypass passage 128 and water pump 120 in parallel and close to one another, the bypass passage 128 can be shortened and piping can be facilitated while heat loss can be reduced.

Hereupon, the water outlet fitting 127 and the water pump 120 may be mounted on the contrary positions so that the coolant water may be supplied to the cylinder block prior to the cylinder head.

As shown in Fig. 15, two coolant water pipings 145 and 146 are connected to the upper portion of the cylinder head 11, the former 145 being connected to the water pump 120 through a heater 147 and the latter 146 being joined to the piping 145 through an oil cooler 148 to be connected to the water pump 120.

The oil cooler 148 is cooled by this coolant water while engine operation, and the heater 147 supplies warm air into the passenger compartment when necessary while engine operation. Since the coolant water temperature is low just after engine start, the regulating valve 125 in the water inlet fitting 123 intercepts the cooling water supply from the radiator 5 making the bypass passage 128 communicative through the action of the thermostat 126, and the coolant water from the cylinder head 11 is circulated by the water pump 120 from the water outlet fitting 127 and the bypass passage 128 through the water pump 120 to the cylinder head 11 and the cylinder block 7.

After the engine is started and the coolant water temperature has reached a prescribed limit, the thermostat 126 of the regulating valve 125 works to communicate the water inlet fitting 123 with the water pump while intercepting the bypass passage 128, and the coolant water is sent to the radiator 5 through the water outlet fitting 127 to be cooled through heat-exchange there, then cools the cylinder head 11 and the cylinder block 7 through circulation by the water pump 120.

Since the coolant water is continually circulated from the coolant water piping 146 connected to the cylinder head 11 through the oil cooler 148 while the engine is running, air is prevented from being collected within the water jacket 135 for the cylinder head 11 even when the coolant water is circulated for cooling from the cylinder head 11 to the cylinder block 7.

The position of the coolant water piping 146 is not limited to one shown in Fig. 5, but may be on the end face of the cylinder head 11 opposite to that on which the second chain 35 is provided as shown in Fig. 14. In this case shown in Fig. 14, since the coolant water piping 146 is connected to the highest position of the water jacket 135, the water jacket 135 can be securely bled of air.

The cylinder head 11 has exhaust pipes 40 and intake pipes 41 connected to each cylinder. Each intake pipe 41 is connected to a surge tank 42 which is extended laterally of the vehicle and supported on the cylinder block 7 through stays 43. This surge tank 42 is provided with a throttle valve 44 at its air inlet end.

As shown in Fig. 1, on one end of the power takeout shaft 16 is provided a flywheel 45 and a clutch mechanism (not shown), so that the power may be transmitted to the front wheel shafts 2 for front wheels 3 through a transmission 47. The primary side of the transmission 47 is disposed on the power takeout shaft 16, and the secondary side is disposed on a countershaft 48 to rotate the front wheel shaft 2 through a gear 49 provided on the wheel shaft 2.

On the other end of the power takeout shaft 16 is provided an auxiliary drive pulley 50 with its periphery accommodated within a concave 51 provided at an end of the cylinder block 7 laterally opposite to a bearing 60 for the crankshaft 6 as shown in Fig. 7, and a belt 55 is wrapped around this auxiliary drive pulley 50 and the auxiliary pulleys for auxiliaries such as alternator 52, power steering pump 53, air compressor 54, etc., so that these auxiliaries are simultaneously driven by the power takeout shaft 16. The tension of this belt 55 can be adjusted through an idler pulley 92.

Although a drive shaft 121, which is rotated through the first chain 33 originally for transmitting the rotation of the power takeout shaft 16 to the countershaft 31, is employed in this embodiment as the drive shaft to which is to be transmitted the rotation of the crankshaft 6, the water pump 120 may be provided instead on the power takeout shaft 16 or on the countershaft 31.

Claims

1. Cooling system for a multiple cylinder internal combustion engine comprising a cylinder head (11) affixed to a cylinder block (7) defining a plurality of cylinders and a cylinder head coolant jacket (135) for circulating coolant between an intake and exhaust side of the cylinder head (11), said cylinder head (11) having at least one intake passage (11c) extending through one side of said cylinder head (11) and at least one exhaust passage (11d) ex-

- tending through another side of said cylinder head (11), **characterised in that** a flow regulating member (138) is provided in the cylinder head coolant jacket (135) between adjacent cylinders (x1, x2) for regulating a transverse flow of coolant through the cylinder head jacket (135) between the intake and exhaust sides thereof.
2. Cooling system for an internal combustion engine comprising a cylinder head (11) affixed to a cylinder block (7), a cylinder head coolant jacket (135) and a cylinder block coolant jacket (134) for circulating coolant through the cylinder head (11) and the cylinder block (7), respectively, particularly as claimed in claim 1, **characterised in that** the cylinder head coolant jacket (135) is communicated with the cylinder block coolant jacket (134) for circulating the coolant therethrough after cooling the cylinder head (11), and a coolant main passage (135a) is formed along one side of the cylinder head (11) for circulating the coolant through the cylinder head coolant jacket transversely from said one side to the opposite side of the cylinder head (11).
 3. Cooling system as claimed in claim 1 or 2, **characterised in that** a plurality of flow regulating members (138) are provided between adjacent cylinders (x1, x2...x6) arranged in line.
 4. Cooling system as claimed in at least one of claims 1 to 3, **characterised in that** the flow regulating members (138) are substantially cross-shaped and provided with guide portions (138a) for directing the coolant flowing from the intake to the exhaust side of the cylinder head (11) towards center portions of the cylinder head (11) provided with a spark plug (13) associated with each of said cylinders (x1, x2).
 5. Cooling system as claimed in at least one of claims 1 to 4, **characterised in that** the flow regulating members (138) are offset from a plane (L1) connecting the center axis of the cylinders (x1, x2) arranged in line towards the exhaust side of the cylinder head (11).
 6. Cooling system as claimed in at least one of claims 1 to 5, **characterised in that** the cylinder head coolant jacket (135) forms a first passage between adjacent cylinders (x1, x2) on the intake side of the cylinder head (11) and a second passage on the exhaust side of the cylinder head (11) between said adjacent cylinders (x1, x2), the width (A) of said first passage being smaller than the width (B) of said second passage.
 7. Cooling system as claimed in at least one of claims 4 to 6, **characterised in that** the guide portions (138a) are integrally formed with the regulating member (138) on opposite sides thereof.
 8. Cooling system as claimed in at least one of claims 1 to 7, **characterised in that** the regulating members (138) are integrally formed with the cylinder head (11).
 9. Cooling system as claimed in at least one of claims 1 to 8, **characterised in that** the cylinder head coolant jacket (135) is formed around three intake passages (11c) associated with three intake valves and two exhaust passages (11d) associated with two exhaust valves for each cylinder (x1, x2) and around a boss portion (136) disposed in front of a coolant jacket passage defined between two intake passages (11c) for directing the coolant towards the regulating member (138).
 10. Cooling system as claimed in claim 9, **characterised in that** the boss portion (136) is provided with guide tip portions for directing the flow of coolant towards the coolant jacket passage defined between the intake passages (11c).
 11. Cooling system as claimed in at least one of claims 1 to 10, **characterised in that** the cylinder head coolant jacket (135) is communicated with the cylinder block coolant jacket (134) via communicating passages (139) disposed at the intake and exhaust side of the regulating member (138), respectively.

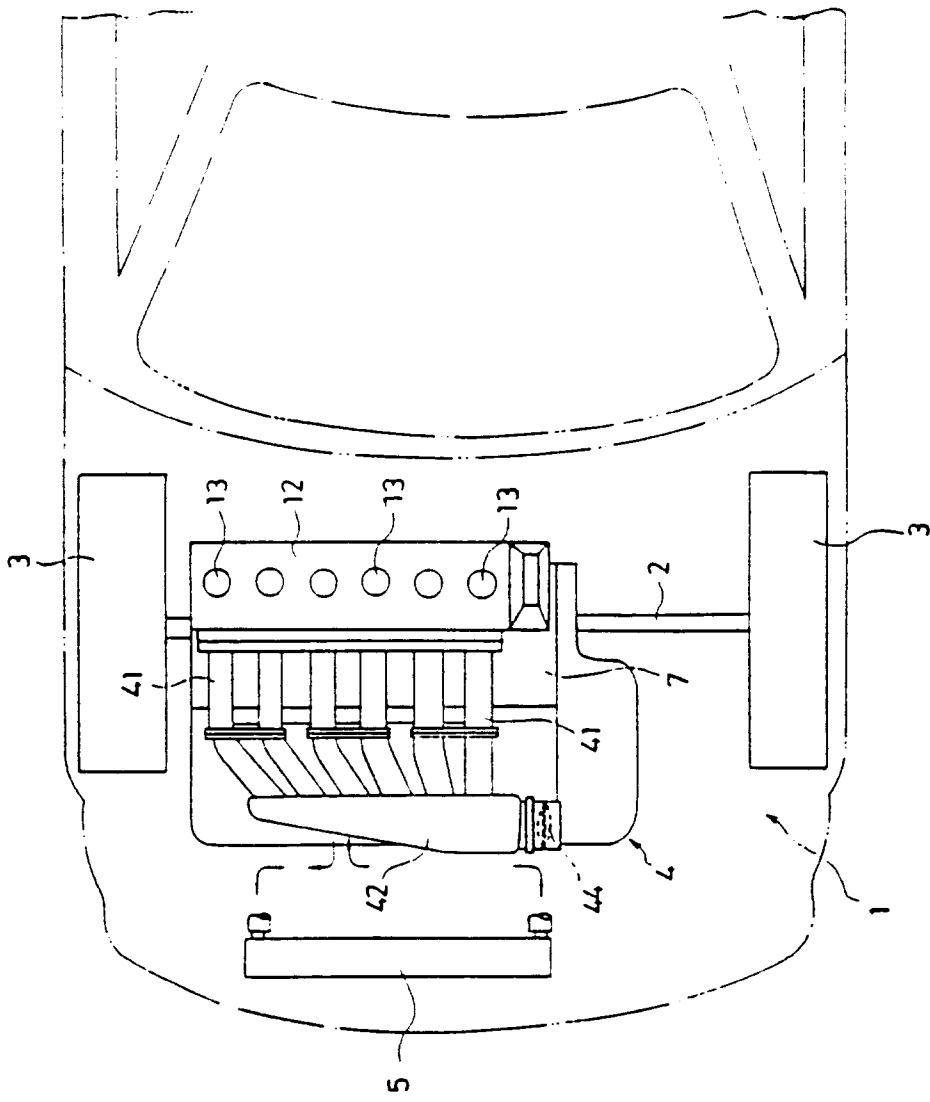

FIG. 2

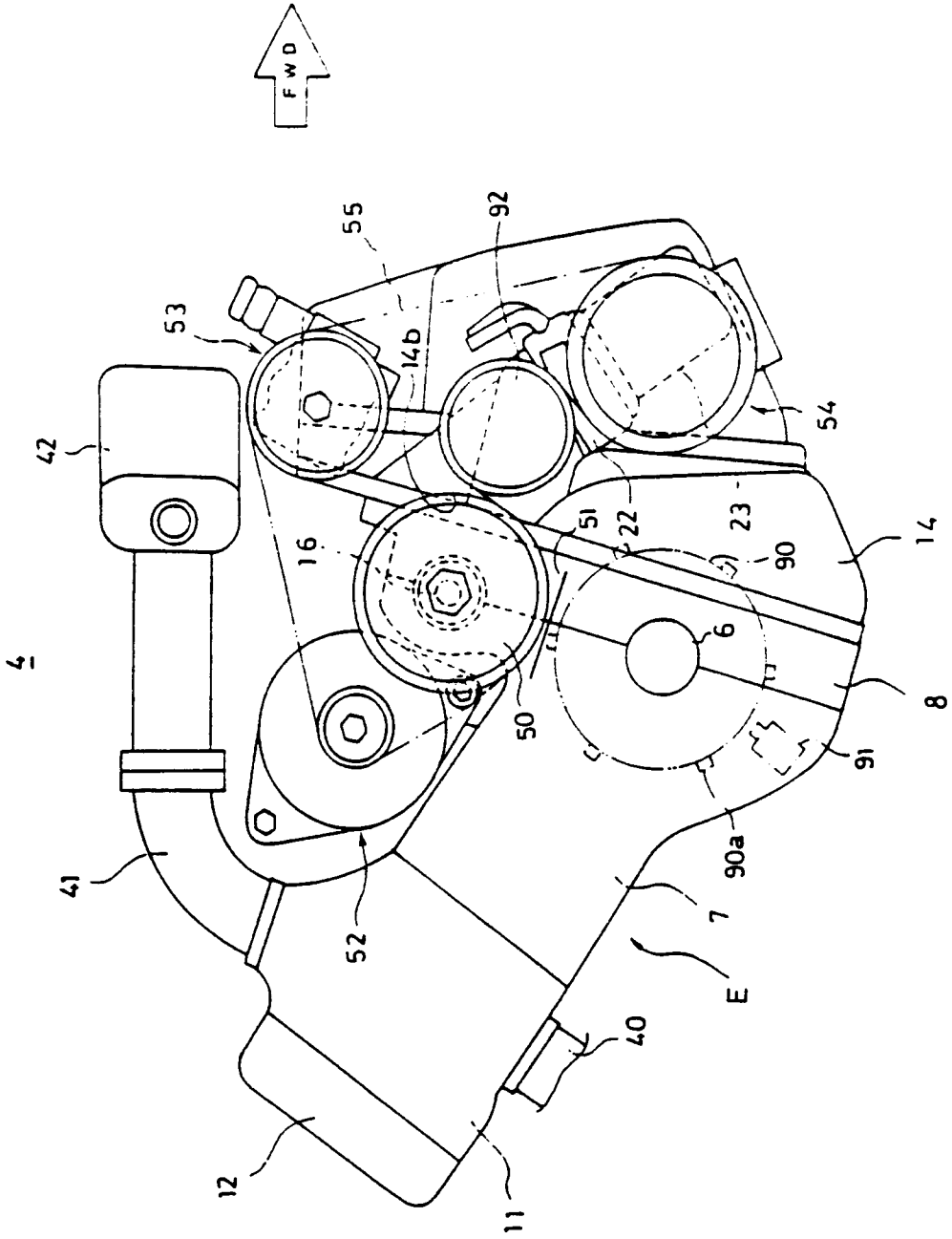

FIG. 3

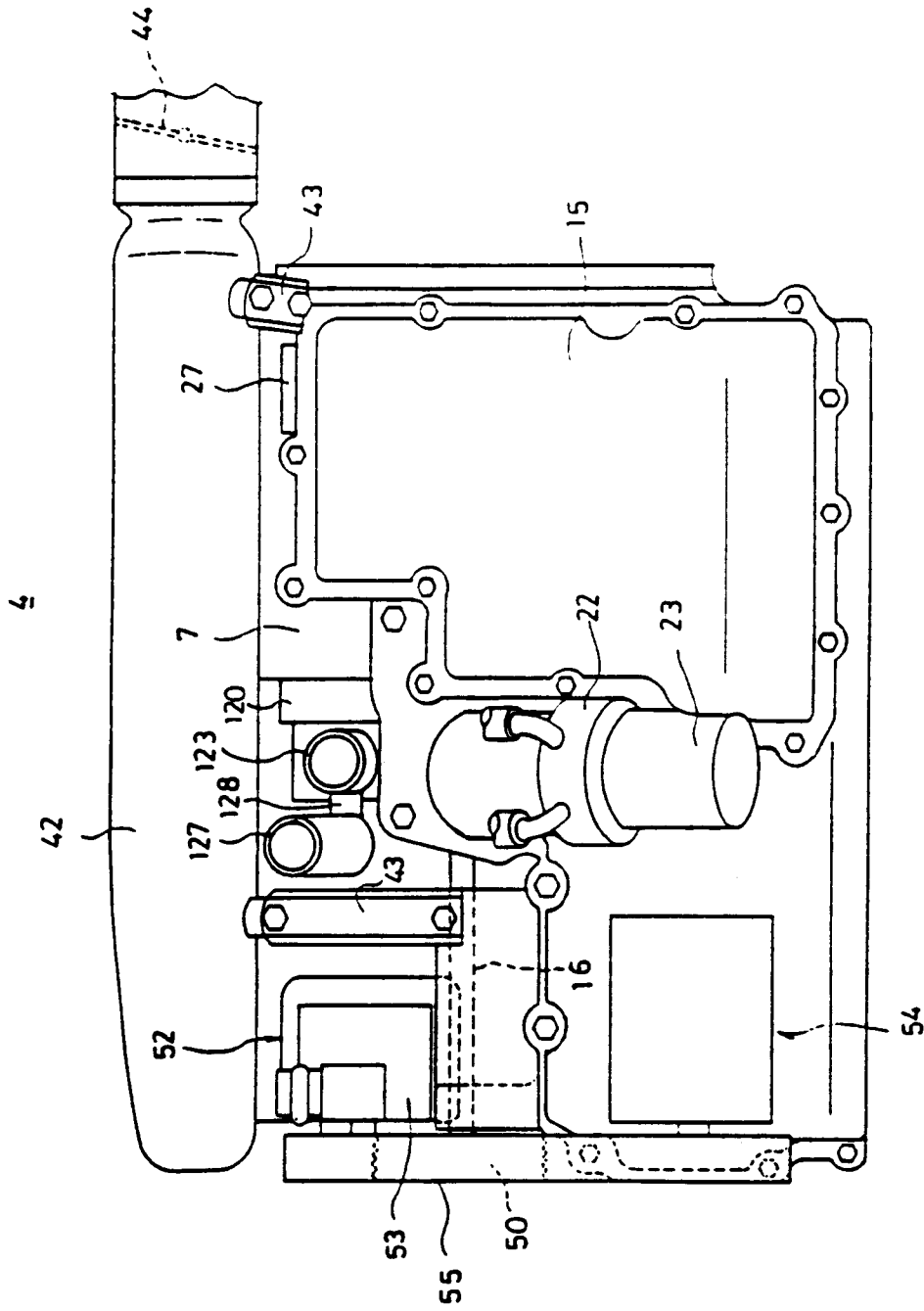

FIG. 4

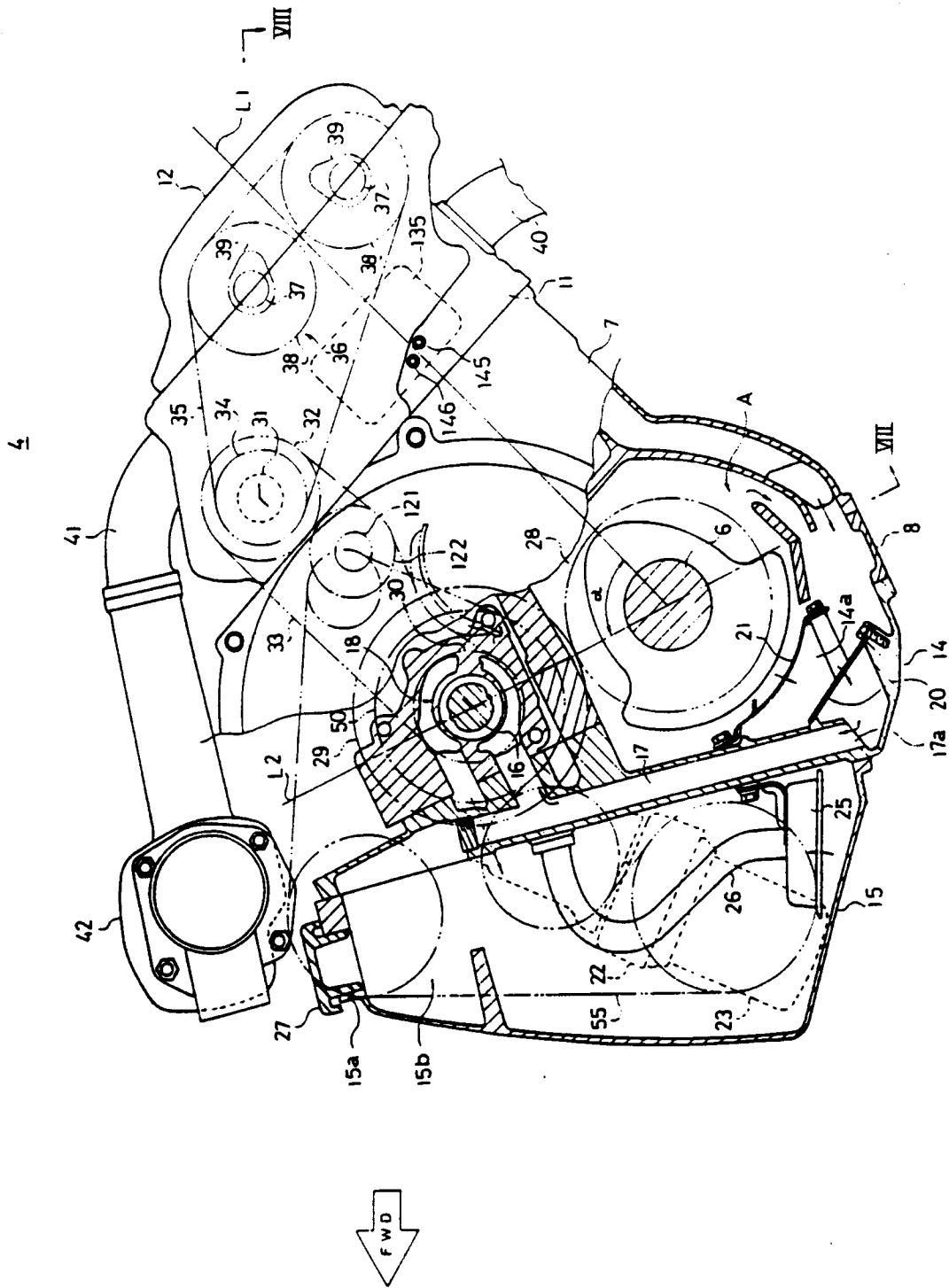
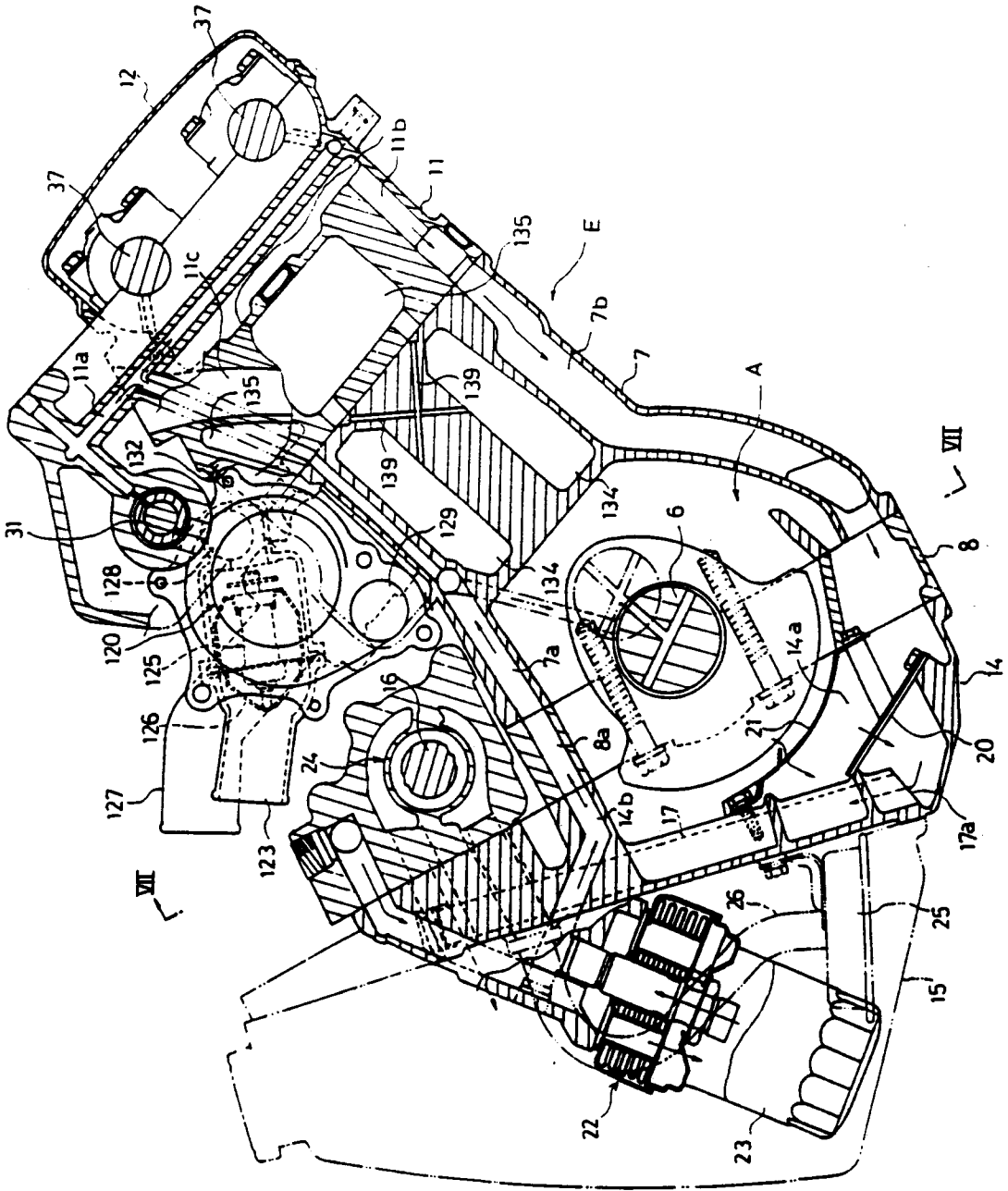
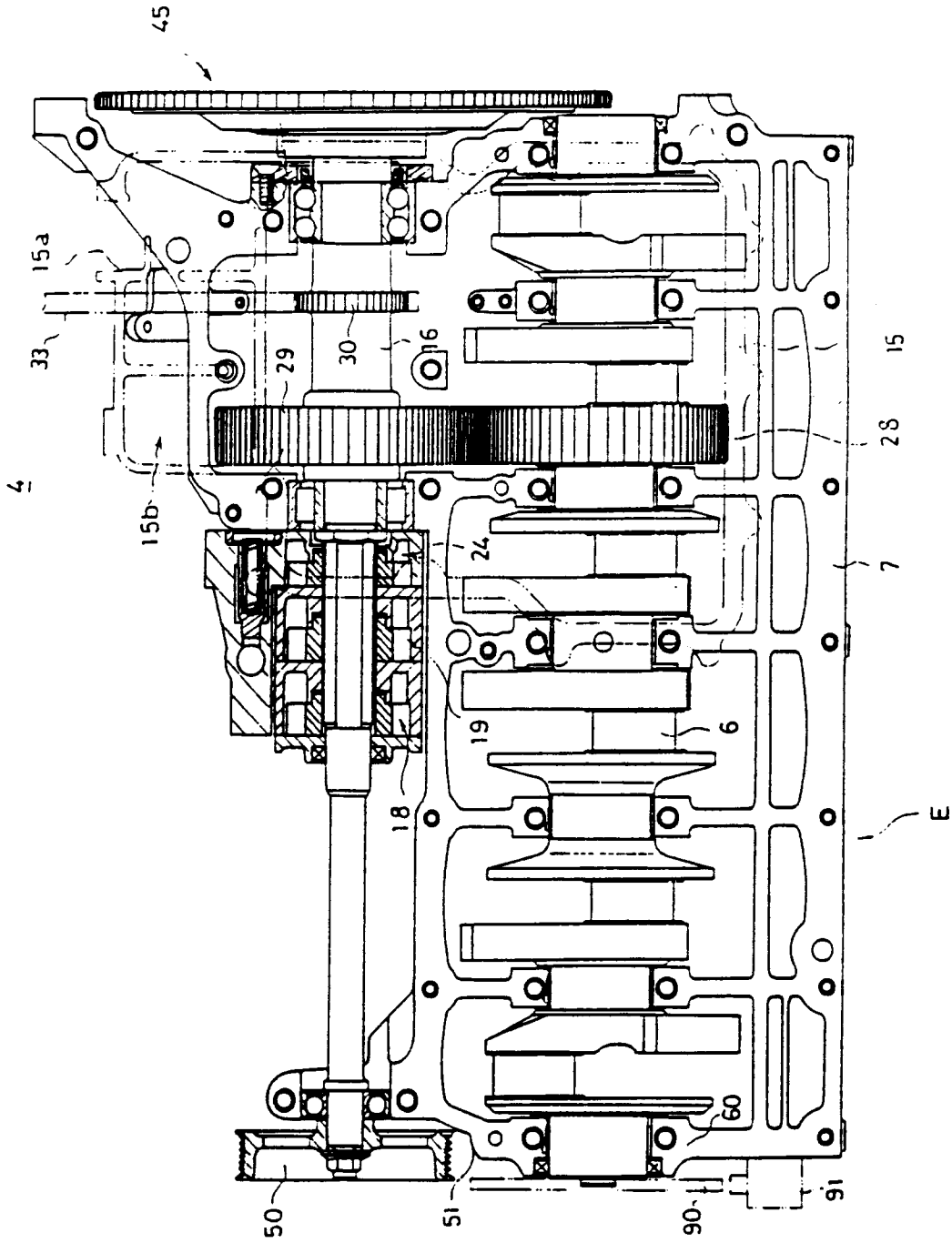
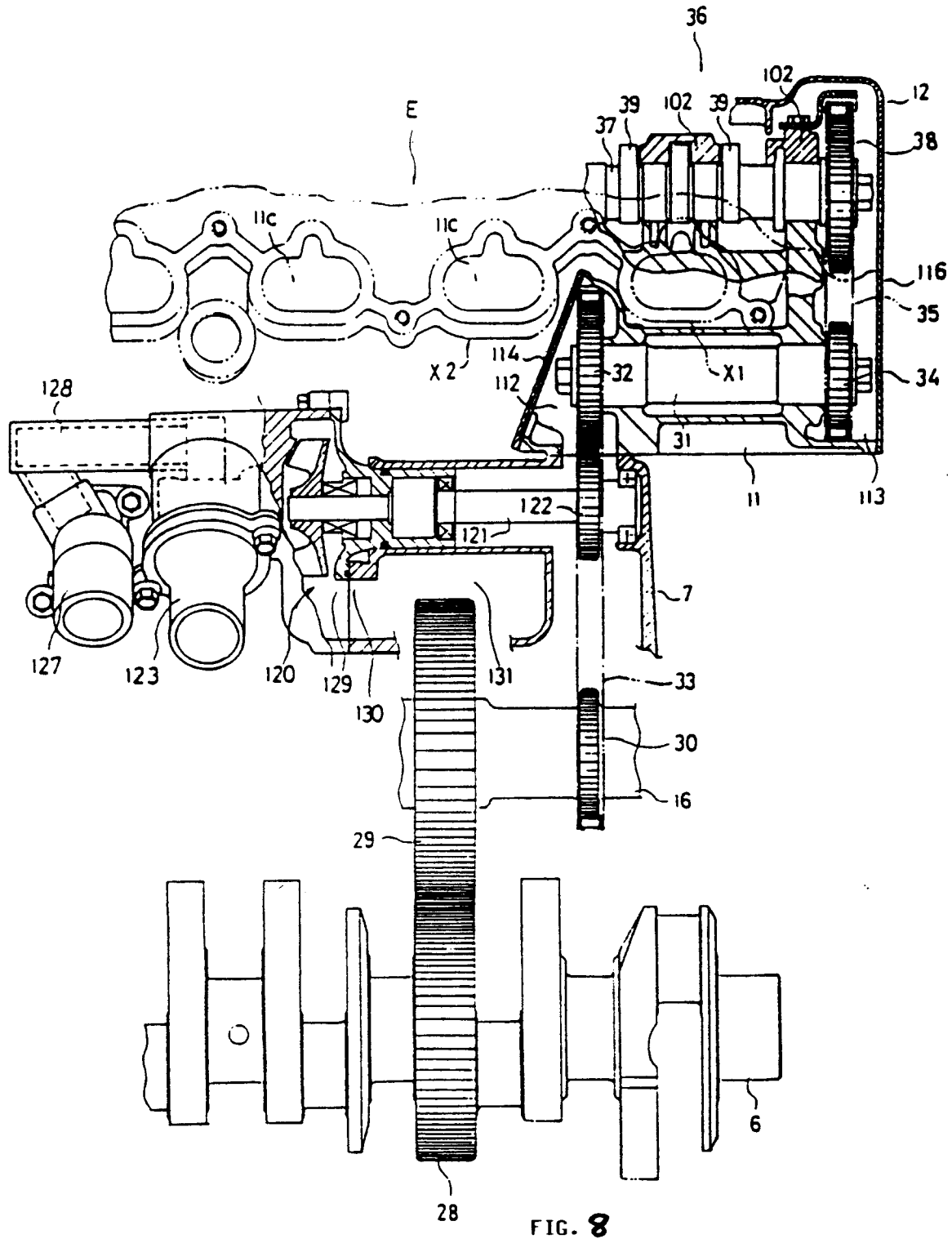

FIG. 5







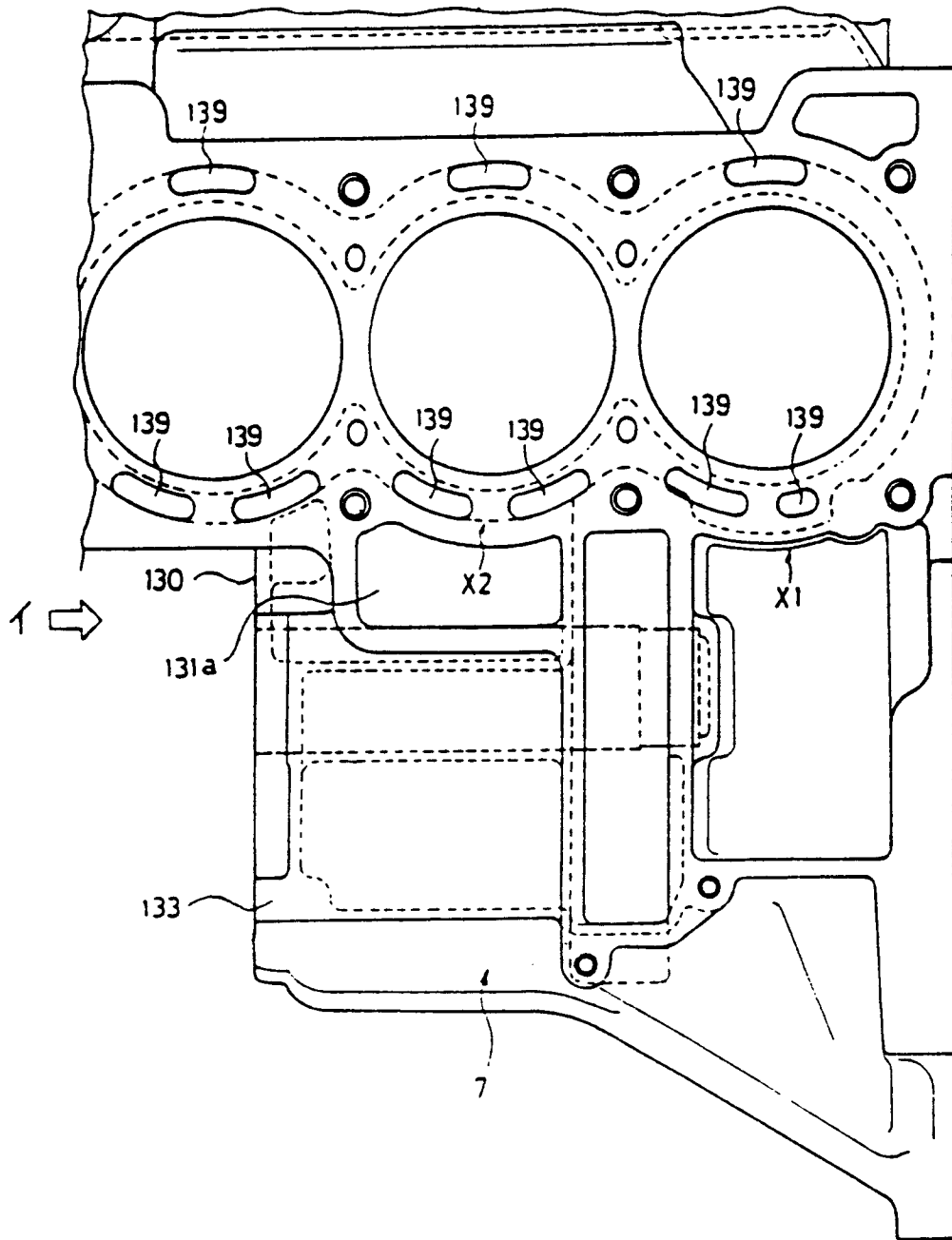

FIG. 9

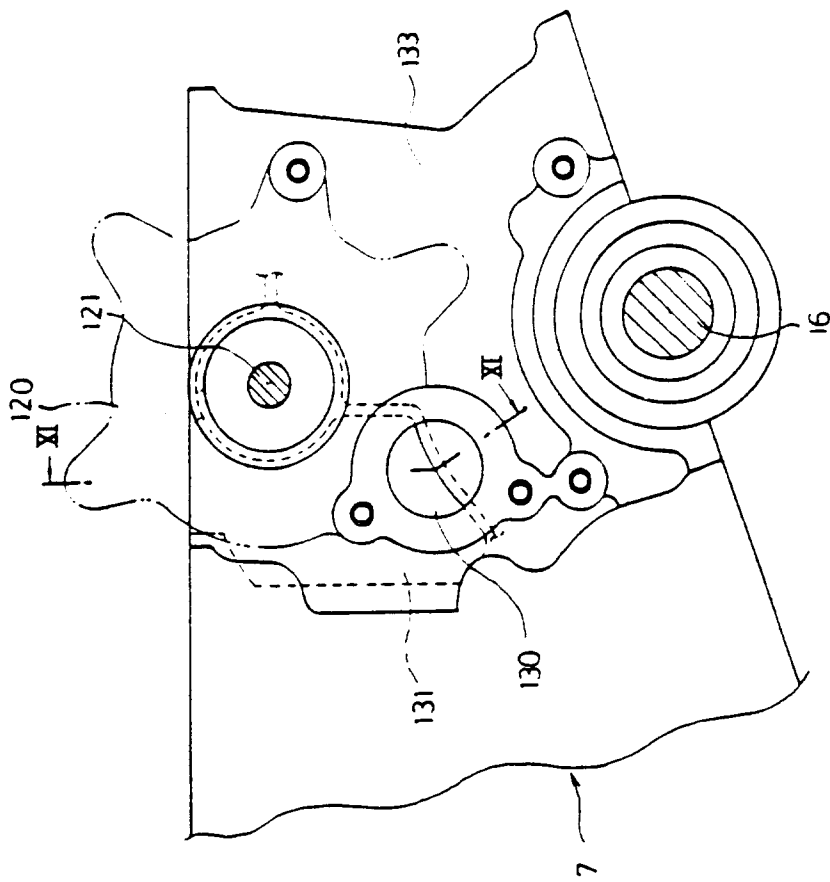

FIG. 1 0

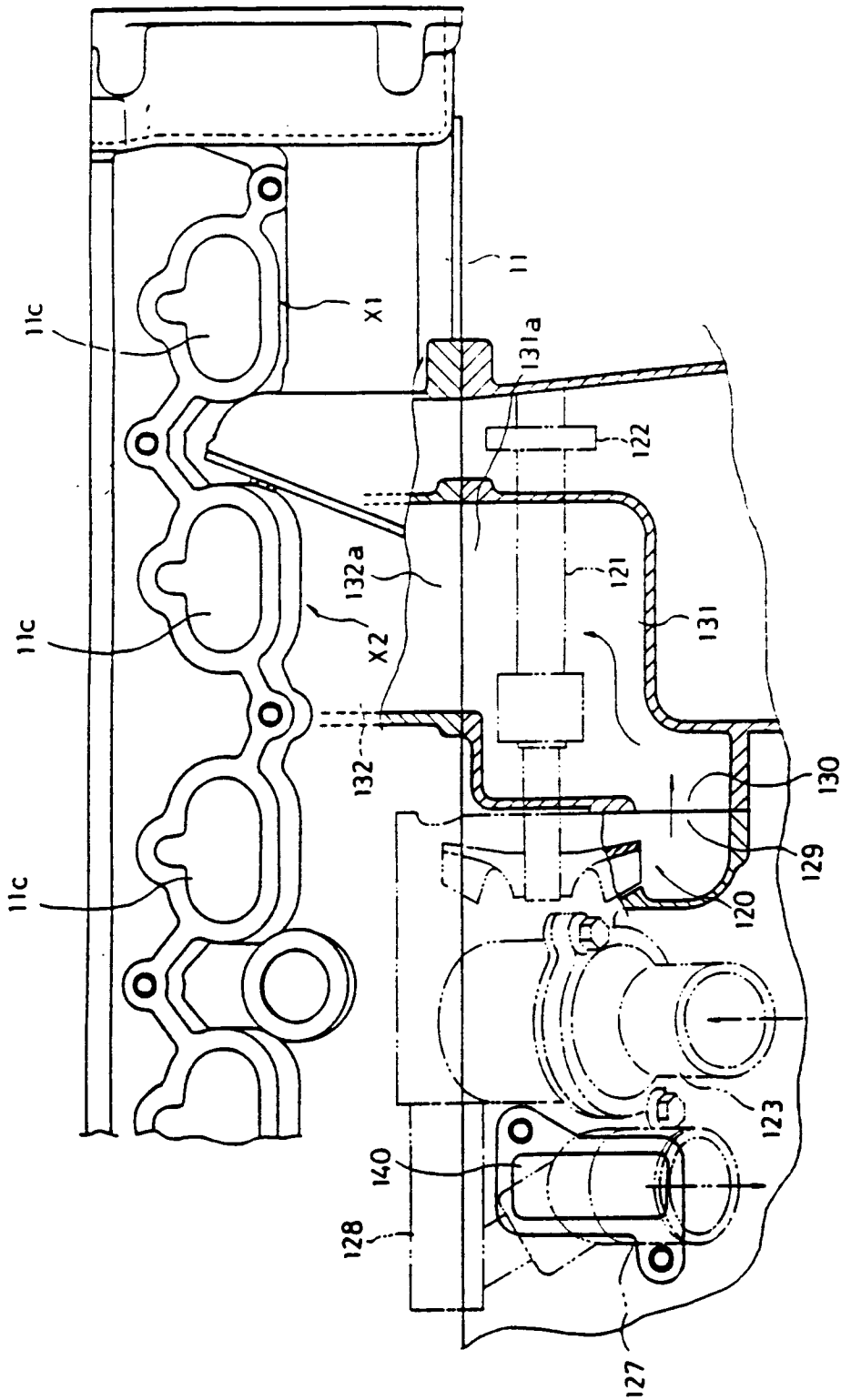

FIG. 11

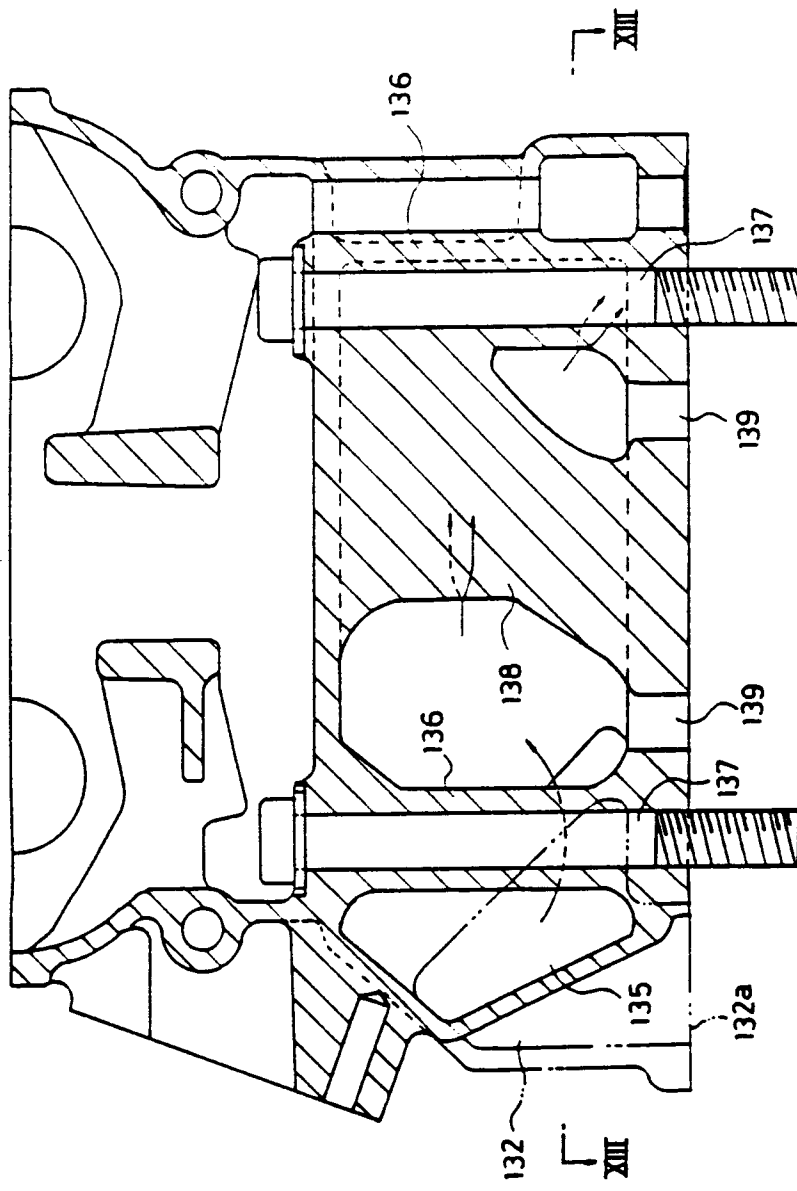

FIG. 12

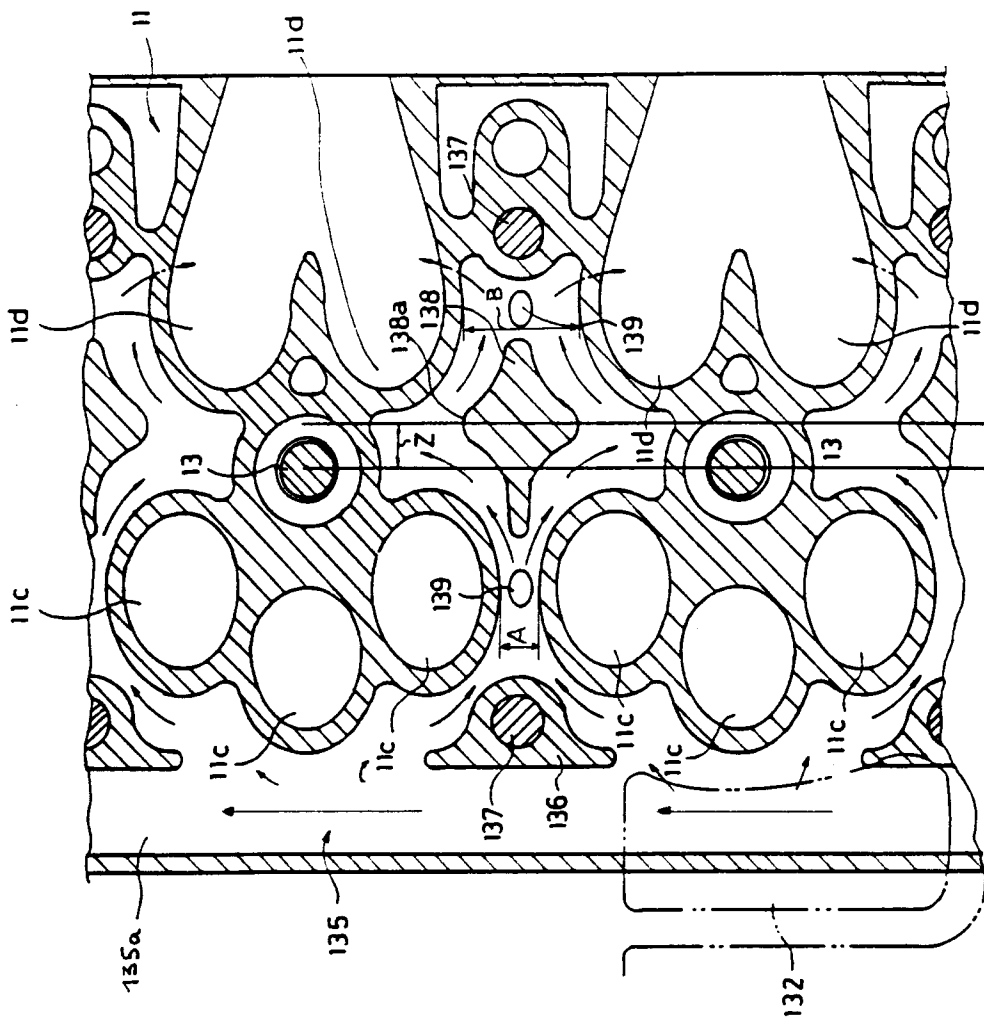

FIG. 13

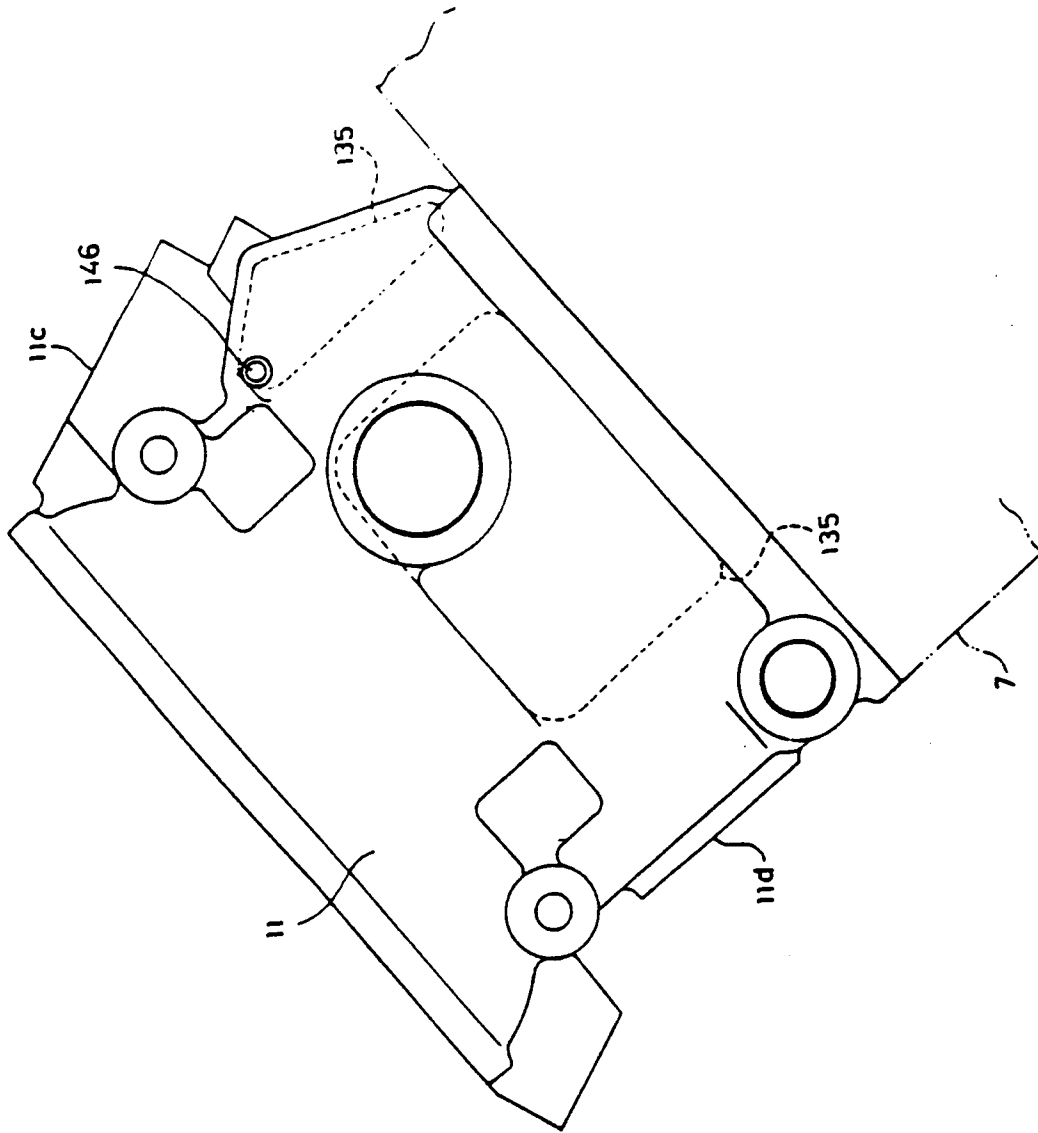

FIG. 14

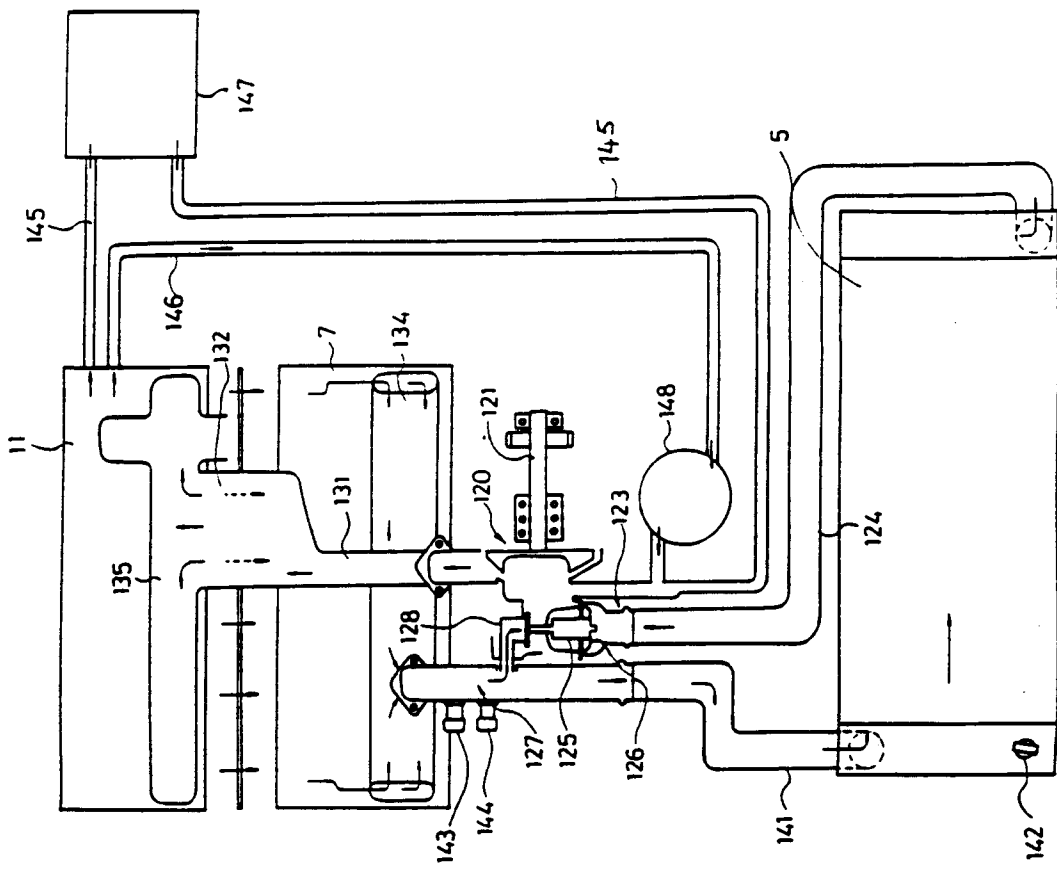

FIG. 15