



(12) **EUROPEAN PATENT APPLICATION**

(43) Date of publication:
07.04.2004 Bulletin 2004/15

(51) Int Cl.7: **F04B 27/10**

(21) Application number: **03022246.7**

(22) Date of filing: **01.10.2003**

(84) Designated Contracting States:
AT BE BG CH CY CZ DE DK EE ES FI FR GB GR
HU IE IT LI LU MC NL PT RO SE SI SK TR
 Designated Extension States:
AL LT LV MK

- Kayukawa, Hiroaki, K.K.Toyota Jidoshokki Aichi-ken (JP)
- Mizutani, Hideki, K.K.Toyota Jidoshokki Aichi-ken (JP)
- Koide, Tatsuya, K.K.Toyota Jidoshokki Aichi-ken (JP)
- Ban, Takahisa, K.K.Toyota Jidoshokki Aichi-ken (JP)

(30) Priority: **04.10.2002 JP 2002292424**

(71) Applicant: **KABUSHIKI KAISHA TOYOTA JIDOSHOKKI**
Kariya-shi, Aichi 448-8671 (JP)

(74) Representative: **HOFFMANN - EITLE**
Patent- und Rechtsanwälte
Arabellastrasse 4
81925 München (DE)

(72) Inventors:
 • **Murase, Masakazu, K.K.Toyota Jidoshokki Aichi-ken (JP)**

(54) **Variable displacement swash plate type compressor**

(57) A variable displacement swash plate type compressor includes a bearing, a thrust bearing, a lug plate and urging means. The urging means is placed between

the bearing and the lug plate and has urging force for reducing thrust force applied to the thrust bearing. The bearing receives radial force and thrust force.

FIG. 1

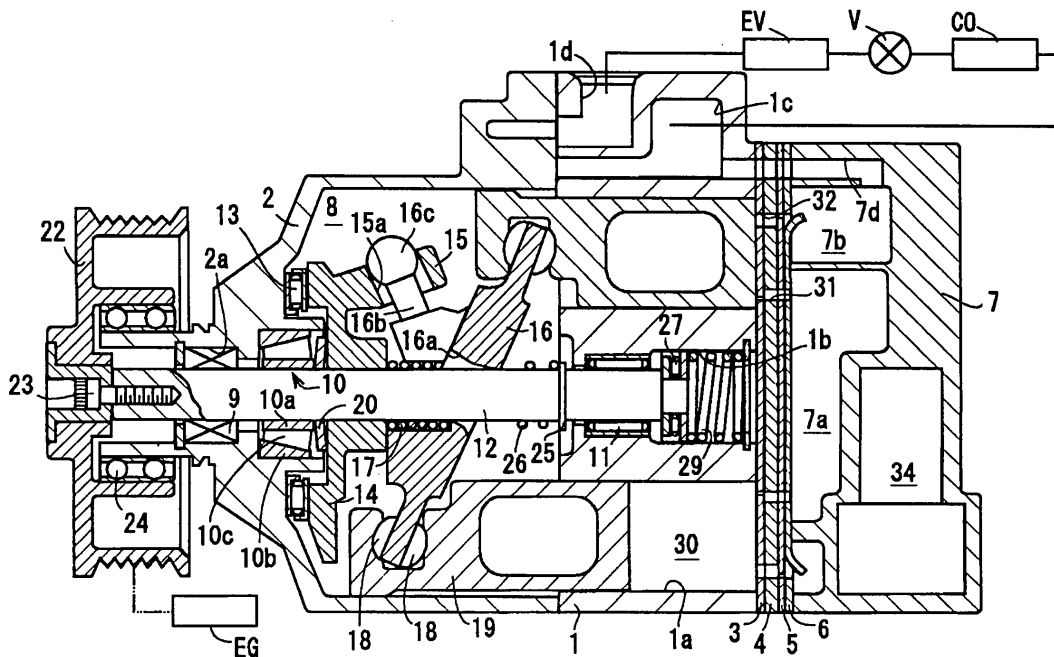

Description

BACKGROUND OF THE INVENTION

[0001] The present invention relates to a variable displacement swash plate type compressor that is applied to a vehicle air conditioning system.

[0002] A compressor is installed in a refrigerant circuit for use in a vehicle air conditioning system. The compressor compresses refrigerant gas therein. In a prior art of Japanese Unexamined Patent Publication No. 2002-13474, more specifically in FIG. 8 thereof, a typical variable displacement swash plate type compressor is disclosed for use in a vehicle air conditioning system. A housing of the compressor includes a front housing, a cylinder block and a rear housing. The rear end of the front housing is joined to the front end of the cylinder block. The rear end of the cylinder block is joined to front end of the rear housing through a valve mechanism that includes a suction valve plate, a valve hole plate, a discharge valve plate and a retainer plate. A plurality of cylinder bores extends through the cylinder block so as to be parallel with each other. The front housing and the cylinder block define a crank chamber therebetween. A suction chamber and a discharge chamber are defined in the rear housing.

[0003] A single-head piston is accommodated in each cylinder bore for reciprocation. A compression chamber is defined in the corresponding cylinder bore between the corresponding piston and the valve mechanism. A first shaft hole extends through the front housing. A first bearing is installed in the first shaft hole. A second shaft hole extends through the cylinder block. A second bearing is installed in the second shaft hole. That is, the first bearing is located frontward than the second bearing. A drive shaft is supported by the first and second bearings for rotation. The front end of the drive shaft protrudes from the front housing and is connected to an external drive source such as a vehicle engine so as to be driven. A support spring is interposed between the rear end of the drive shaft and the valve mechanism through a third bearing in the second shaft hole. The rear end of the drive shaft is in contact with the front end of the third bearing. The rear end of the third bearing is in contact with the front end of the support spring. The rear end of the support spring is in contact with the front end of the valve mechanism. The support spring urges the drive shaft frontward.

[0004] A lug plate is fixed to the drive shaft in the crank chamber so as to integrally rotate with the drive shaft. A thrust bearing is interposed between a front wall of the front housing and the lug plate in the crank chamber. A swash plate is supported by the drive shaft in the crank chamber for rotation. A hinge mechanism is interposed between the lug plate and the swash plate. Thereby, the swash plate is synchronously rotated with the drive shaft and is inclinable with respect to a rotary axis of the drive shaft. Also, the pistons engage with the periphery of the

swash plate. Thus, the piston is reciprocated in the corresponding cylinder bore in accordance with the rotation of the swash plate. A control mechanism is installed in the rear housing and communicates with the crank chamber, the suction chamber and the discharge chamber. The control mechanism controls the pressure in the crank chamber.

[0005] In the compressor, while the drive shaft is driven, the swash plate oscillates in accordance with the inclination angle of the swash plate and thus the piston is reciprocated in the corresponding cylinder bore. Therefore, refrigerant gas in the suction chamber is drawn into the compression chamber, and the refrigerant gas is compressed therein, and then the compressed refrigerant gas in the compression chamber is discharged into the discharge chamber. During the above process of the compressor, if the control mechanism controls the pressure in the crank chamber, since the inclination angle of the swash plate is varied, an amount of the refrigerant gas discharged from the compression chamber to the discharge chamber is also varied. That is, as the pressure in the crank chamber is raised, the inclination angle of the swash plate becomes small and the discharge amount of the refrigerant gas is reduced. In contrast, as the pressure in the crank chamber is lowered, the inclination angle of the swash plate becomes large and the discharge amount of the refrigerant gas is increased.

[0006] On the other hand, during the above process of the compressor, the first bearing and the second bearing receive radial force that is applied to the drive shaft respectively in the front housing and the cylinder block. The thrust bearing receives compressive reaction force of the refrigerant gas through the piston, the shoes, the swash plate and the lug plate in the front housing. In addition, in the compressor, the crank chamber and the second shaft hole are communicated via the second bearing, and the support spring is interposed between the rear end of the drive shaft and the valve mechanism. Therefore, the thrust bearing receives the pressure in the crank chamber and urging force of the support spring, which are applied to the drive shaft and the lug plate.

[0007] In the above prior art, however, since only the thrust bearing that is placed between the front housing and the lug plate in the crank chamber receives all of the compressive reaction force, the pressure in the crank chamber and the urging force of the support spring and rolling diameter of the thrust bearing is larger than that of the first bearing and the second bearing, power loss of the thrust bearing is relatively large.

[0008] Meanwhile, in a compressor that is disclosed in the above publication, a cylindrical regulating member is fitted around a rear end of a drive shaft so as to have a slight clearance between the cylindrical regulating member and a valve mechanism without the support spring in the shaft hole of the cylinder block between the rear end of the drive shaft and the valve mechanism. In the disclosed compressor, a thrust bearing does not re-

quire receiving the urging force of the support spring. Therefore, power loss is reduced.

[0009] Even in the compressor, however, the thrust bearing still receives both of the compressive reaction force and the pressure in the crank chamber. Therefore, the power loss is not sufficiently reduced. In particular, in a state that the pressure in the crank chamber is relatively high and displacement of the compressor is relatively small, although the compressive reaction force is not so large, since the drive shaft is urged forward by force caused due to the high pressure in the crank chamber, the power loss in the state is not ignored.

SUMMARY OF THE INVENTION

[0010] The present invention is directed to a variable displacement swash plate type compressor whose power loss is reduced.

[0011] The present invention has the following features. A variable displacement swash plate type compressor is used in connection with an external drive source. The compressor includes a housing, a first bearing, a drive shaft, a lug plate, a swash plate, a single-head piston, a control mechanism and urging means. In the housing, a cylinder bore, a crank chamber, a suction chamber and a discharge chamber are defined. The first bearing is accommodated on a front side of the housing. The first bearing receives radial force and thrust force. The drive shaft is supported by the first bearing in the housing rotatably. The lug plate is fixed to the drive shaft in the crank chamber. The swash plate is supported by the drive shaft in the crank chamber rotatably. The single-head piston is accommodated in the cylinder bore reciprocally and is connected to the swash plate so as to reciprocate in accordance with the rotation of the swash plate. The control mechanism communicates with the crank chamber, the suction chamber and the discharge chamber for controlling pressure in the crank chamber. The urging means is placed between the first bearing and the lug plate and has urging force for reducing thrust force applied to the first thrust bearing.

BRIEF DESCRIPTION OF THE DRAWINGS

[0012] The features of the present invention that are believed to be novel are set forth with particularity in the appended claims. The invention, together with objects and advantages thereof, may best be understood by reference to the following description of the presently preferred embodiments together with the accompanying drawings in which:

FIG. 1 is a cross sectional view illustrating a variable displacement swash plate type compressor according to a first preferred embodiment of the present invention;

FIG. 2 is a partially enlarged view of FIG. 1;

FIG. 3 is a partially enlarged view of FIG. 1; and

FIG. 4 is a partial cross sectional view illustrating a variable displacement swash plate type compressor according to a second preferred embodiment of the present invention.

DETAILED DESCRIPTION OF THE PREFERRED EMBODIMENTS

[0013] A variable displacement swash plate type compressor according to a first preferred embodiment of the present invention is applied to a vehicle air conditioning system. The compressor will now be described with reference to FIGs. 1 through 3. In FIG. 1, a left side of the drawing is a front side and a right side thereof is a rear side.

[0014] Referring to FIG. 1, the rear end of a cup-shaped front housing 2 is joined to the front end of a cylinder block 1. The rear end of the cylinder block 1 is joined to the front end of a rear housing 7 through a valve mechanism that includes a suction valve plate 3, a valve hole plate 4, a discharge valve plate 5 and a retainer plate 6. The cylinder block 1, the front housing 2 and the rear housing 7 form a compressor housing. In the cylinder block 1, a plurality of cylinder bores 1 a, a shaft hole 1 b, a muffler chamber 1 c and an inlet 1 d are defined. In the front housing 2, a shaft hole 2 a is formed. The cylinder block 1 and the front housing 2 define a crank chamber 8 therein.

[0015] Still referring to FIG. 1, a drive shaft 12 extends through the crank chamber 8 and is supported by a first bearing 10 at the shaft hole 2 a and by a second bearing 11 at the shaft hole 1 b rotatably. A shaft seal device 9 seals a clearance between the drive shaft 12 and the front housing 2. In the first embodiment, a tapered roller bearing is adopted as the first bearing 10. Also, a radial bearing is adopted as the second bearing 11.

[0016] As shown in FIGs. 2 and 3, the first bearing 10 includes an inner race 10 a, an outer race 10 b, a plurality of rollers 10 c and a cage, which is not shown in the drawings. The drive shaft 12 is press-fitted inside the inner race 10 a so as to integrally rotate with the inner race 10 a. The outer race 10 b is press-fitted into the front housing 2. The plurality of rollers 10 c is interposed between the inner race 10 a and the outer race 10 b. A rolling contact surface of the inner race 10 a is formed on a cylindrical surface whose central axis is the same as a rotary axis of the drive shaft 12. A rolling contact surface of the outer race 10 b is formed on a tapered surface whose central axis is the same as the rotary axis of the drive shaft 12. The rolling contact surface of the outer race 10 b is formed in such a manner that diameter of the rolling contact surface of the outer race 10 b on the front side of the first bearing 10 becomes smaller than that on the rear side of the first bearing 10. Each of the rollers 10 c is formed in such a manner that diameter of each of the rollers 10 c on the front side of the first bear-

ing 10 becomes smaller than that on the rear side of the first bearing 10. That is, each of the rollers 10c has the shape of a circular truncated cone.

[0017] Referring back to FIG. 1, a lug plate 14 is fixed to the drive shaft 12 in the crank chamber 8 so as to integrally rotate with the drive shaft 12. A thrust bearing 13 is placed between a front wall of the front housing 2 and the lug plate 14 in the crank chamber 8. The drive shaft 12 extends through a coned disc spring 20 which is placed between the inner race 10a and the lug plate 14. The coned disc spring 20 is served as an urging means. Urging force f_0 of the coned disc spring 20 is applied to the lug plate 14 rearward.

[0018] Still referring to FIG. 1, a pair of arms 15 protrudes from the rear surface of the lug plate 14 rearward, although only one of the arms 15 is shown in FIG. 1. A cylindrical guide hole 15a is formed through each arm 15. The drive shaft 12 extends through a swash plate 16 where a through hole 16a is formed. An inclination angle of the swash plate 16 is defined as an angle between a perpendicular plane to the rotary axis of the drive shaft 12 and the swash plate 16. A spring 17 is interposed between the swash plate 16 and the lug plate 14 for reducing the inclination angle of the swash plate 16. A return spring 26 is interposed between the swash plate 16 and a circular clip 25. A bearing 27 is placed at the rear end of the drive shaft 12 in the shaft hole 1 b of the cylinder block 1. A support spring 29 is interposed between the bearing 27 and the suction valve plate 3. A regulating member may be used in place of the bearing 27 and the support spring 29.

[0019] A pair of guide pins 16b protrudes from the front end of the swash plate 16 respectively to the pair of arms 15, although only one of the guide pins 16b is shown in FIG. 1. A spherical guide portion 16c is formed on the distal end of each guide pin 16b so as to pivotally slide along the corresponding guide hole 15a. The guide holes 15a of the lug plate 14 and the guide portions 16c of the swash plate 16 constitute a hinge mechanism, through which the swash plate 16 is rotated synchronously with the drive shaft 12 and inclines relative to the drive shaft 12. A plurality of hollow single-head pistons 19 is engaged with the periphery of the swash plate 16. Each piston 19 has a pair of shoes 18, which is placed respectively at the front and rear sides of the swash plate 16. Each piston 19 is also accommodated in each cylinder bore 1 a. A compression chamber 30 is defined on the rear side of the piston 19 in the corresponding cylinder bore 1 a.

[0020] A pulley 22 is fixed to the front end of the drive shaft 12, which protrudes from the front housing 2 frontward, by a bolt 23. The pulley 22 is supported by a ball bearing 24 on the front housing 2 rotatably. A belt is partially wound around the pulley 22 so as to connect with an engine EG, which is served as an external drive source.

[0021] In the rear housing 7, a suction chamber 7a is defined. The suction chamber 7a and the inlet 1 d of the

cylinder block 1 are communicated via a suction passage, which is not shown in FIG. 1. The suction chamber 7a and the cylinder bores 1 a are communicated respectively via suction ports 31, which are formed through the retainer plate 6, the discharge valve plate 5 and the valve hole plate 4. The inlet 1 d is connected to an evaporator EV of a refrigerant circuit by a piping. The evaporator EV is connected to a condenser CO through an expansion valve V by a piping. Also, in the rear housing 7, a discharge chamber 7b is defined around the suction chamber 1 a. The discharge chamber 7b and the muffler chamber 1 c of the cylinder block 1 are communicated via a discharge passage 7d, which extends through the retainer plate 6, the discharge valve plate 5, the valve hole plate 4 and the suction valve plate 3. The muffler chamber 1 c is connected to the condenser CO of the refrigerant circuit by a piping. The discharge chamber 7b is connected to the cylinder bores 1 a respectively by discharge ports 32, which extends through the valve hole plate 4 and the suction valve plate 3. Further, a control mechanism 34, which communicates with the crank chamber 8, the suction chamber 7a and the discharge chamber 7b so as to control the pressure in the crank chamber 8, is accommodated in the rear housing 7. The control mechanism 34 is capable of adjusting the pressure in the crank chamber 8, for example, by detecting the pressure in the suction chamber 7a. Thereby, an amount of refrigerant gas discharged from the compression chamber 30 to the discharge chamber 7b is varied in accordance with reciprocation of the piston 19 based on an inclination of the swash plate 16.

[0022] The above structured compressor compresses carbon dioxide filled in the refrigerant circuit. Carbon dioxide is served as a refrigerant gas. Specifically, while the engine EG drives, since the pulley 22 is rotated through the belt, the drive shaft 12 is continuously driven. Thereby, the swash plate 16 is oscillated and the piston 19 is reciprocated in the corresponding cylinder bore 1 a. That is, the piston 19 is reciprocated in accordance with the rotation of the swash plate 16. Thus, refrigerant gas of the evaporator EV in the refrigerant circuit is drawn into the suction chamber 7a through the inlet 1 d and the refrigerant gas in the suction chamber 7a is drawn into the compression chamber 30. After the refrigerant gas in the compression chamber 30 is compressed therein, the compressed refrigerant gas is discharged into the discharge chamber 7b. The refrigerant gas in the discharge chamber 7b is discharged into the condenser CO through the muffler chamber 1c.

[0023] During the compressive process of the compressor, the first and second bearings 10 and 11 receive radial force which is applied to the drive shaft 12 respectively in the front housing 2 and the cylinder block 1. Also, compressive reaction force of the refrigerant gas is transmitted to the piston 19, the shoes 18, the swash plate 16 and the lug plate 14. Further, in the compressor the crank chamber 8 communicates with the shaft hole 1 b of the cylinder block 1 through the second bearing

11 and the support spring 29 is interposed between the rear end of the drive shaft 12 and the valve mechanism. Therefore, the pressure in the crank chamber 8 is applied to the drive shaft 12 and the lug plate 14. In addition, urging force of the support spring 29 is applied to the drive shaft 12 and the lug plate 14. Note that the force applied to the drive shaft 12 frontward in accordance with the pressure in the crank chamber 8 is f_1 . Also, note that the urging force of the support spring 29 is f_2 , and that the compressive reaction force is f_3 . In this case, the urging force f_0 of the coned disc spring 20 is set so as to be larger than resultant force of the force f_1 which is the maximum value and the urging force f_2 of the support spring 29.

[0024] In such a compressor, when a vehicle is stopped and the engine EG is stopped, or when the vehicle is accelerated, or when a vehicle air conditioning system is switched off in a state that the engine EG drives, the control mechanism 34 raises the pressure in the crank chamber 8. Thereby, the inclination angle of the swash plate 16 becomes minimum. Thus, a volume of the compression chamber 30 becomes minimum and the amount of refrigerant gas discharged from the compression chamber 30 becomes minimum.

[0025] In the above state of the compressor, the force f_1 based on the pressure in the crank chamber 8 becomes the maximum value. The urging force f_2 is a fixed value. The compressive reaction force f_3 is an extremely small value. Meanwhile, when the engine EG and the compressor is started, or when the vehicle is normally run, or when the vehicle air conditioning system is switched on in a state that the engine EG drives, as shown in FIG. 2, the drive shaft 12 is urged frontward by resultant force of the force f_1 , the urging force f_2 and the extremely small compressive reaction force f_3 . Therefore, the lug plate 14 is also urged frontward. In the compressor, however, since the urging force f_0 of the coned disc spring 20 is set so as to be larger than resultant force of the maximum force f_1 , which is the maximum value, and the urging force f_2 of the support spring 29, the drive shaft 12 and the lug plate 14 are urged rearward. For this reason, a slight clearance is produced between the lug plate 14, that is, the thrust bearing 13, and the thrust bearing 13 does not receive thrust force. Consequently, rolling frictional force of the thrust bearing 13 is not generated and power loss is reduced.

[0026] In this case, the thrust force which is applied to the coned disc spring 20 is received by the first bearing 10 through the inner race 10a. In other words, since the inner race 10a prevents the coned disc spring 20 from sliding over the drive shaft 12, power loss is reduced due to sliding frictional force. Thus, in this state, only the first bearing 10 receives thrust force and radial force. Therefore, operation of the compressor is not interrupted. In addition, since the tapered roller bearing is adopted as the first bearing 10, the number of parts is reduced.

[0027] Thus, when the compressor is started in such a manner that displacement of the compressor is minimum, reduction of the power loss accomplished by the first bearing 10 and the thrust bearing 13 is described as follows. If frictional force generated on the first bearing 10 is F_1 , coefficient of friction of the first bearing 10 is μ_1 and thrust force which is applied to the first bearing 10 is N_1 , F_1 gives the following equation:

$$F_1 = \mu_1 \times N_1$$

[0028] If the pressure in the crank chamber 8 is P and the diameter of the drive shaft 12 is D , the thrust force, which is applied to the first bearing 10, gives the following equation:

$$N_1 = P \times \pi / 4 \times D^2$$

[0029] Meanwhile, if the rolling diameter of the first bearing 10 is R_1 , torque T_1 which is generated on the first bearing gives the following equation:

$$T_1 = F_1 \times R_1$$

[0030] From the above equations, the torque T_1 , which is generated on the first bearing 10, gives the following equation:

$$T_1 = \mu_1 \times P \times \pi / 4 \times D^2 \times R_1$$

[0031] If frictional force generated on the thrust bearing 13 is F_2 , coefficient of friction of the first bearing 10 is μ_2 , thrust force which is applied to the first bearing 10 is N_2 and the rolling diameter of the second bearing 12 is R_2 , T_2 , which is generated on the thrust bearing 13, gives the following equation:

$$T_2 = \mu_2 \times P \times \pi / 4 \times D^2 \times R_2$$

[0032] Thus, gross torque T that are generated on the first bearing 10 and the thrust bearing 13 gives the following equation:

$$\begin{aligned} T &= T_1 + T_2 \\ &= P \times \pi / 4 \times D^2 \times (\mu_1 \times R_1 + \mu_2 \times R_2) \end{aligned}$$

[0033] In the first embodiment, as described above, when the compressor is started in such a manner that

displacement of the compressor is minimum, the torque T2 is not generated on the thrust bearing 13. Therefore, the gross torque T gives the following equation:

$$T=T1$$

$$= \mu 1 \times P \times \pi / 4 \times D^2 \times R1$$

[0034] From the above equations, in comparison with a case that torque is generated on both of the first bearing 10 and the thrust bearing 13, in a case that torque is generated only on the first bearing 10 whose rolling diameter is relatively small, it is found that relatively small torque is generated on the drive shaft 12. That is, in the compressor of the first embodiment, power loss is reduced. Therefore, when the compressor is started, load that is applied to the engine EG is reduced. In the compressor especially where carbon dioxide is used as a refrigerant gas in view of environmental problem, the above effect is remarkable.

[0035] On the other hand; in the compressor, if the control mechanism 34 lowers the pressure in the crank chamber 8 in a state that the engine EG drives, the inclination angle of the swash plate 16 becomes maximum. Thus, the volume of the compression chamber 30 becomes maximum and the amount of refrigerant gas discharged from the compression chamber 30 becomes maximum.

[0036] In the above state of the compressor, the force f1 becomes a minimum value. The urging force f2 is a fixed value. The compressive reaction force f3 is maximum. Therefore, as shown in FIG. 3, the drive shaft 12 is urged frontward by resultant force of the force f1, the urging force f2 and the maximum compressive reaction force f3. Therefore, the lug plate 14 is also urged frontward. In this case, the urging force f0 of the coned disc spring 20 is defeated because the compressive reaction force f3 becomes maximum. Thereby, the coned disc spring 20 is squeezed between the inner race 10a of the first bearing 10 and the lug plate 14. Thus, the drive shaft 12 and the lug plate 14 are urged frontward.

[0037] At this time, while the thrust bearing 13 receives the lug plate 14, the urging force f0 of the coned disc spring 20 urges the lug plate 14 rearward. Therefore, thrust force which the thrust bearing 13 receives is restrained. That is, in the above equation, the torque T2, which is generated on the thrust bearing 13, is reduced. Therefore, in the compressor of the first embodiment, even in a state that an amount of refrigerant gas discharged from the compressor is relatively large, power loss is reduced. Thereby, while the compressor is driven, load that is applied to the engine EG is reduced. Thus, in the compressor of the first embodiment, power loss is reduced.

[0038] Further, in the compressor, the coned disc spring 20 is placed within a relatively short distance between the inner race 10a of the first bearing 10 and the lug plate 14 and operates the urging force f0 therein. Therefore, the length of the drive shaft 12 is shortened. Thereby, a relatively compact compressor is materialized.

[0039] Further, even in a case that an electromagnetic clutch is used without directly placing the pulley 22 around the drive shaft 12 of the compressor, while the engine EG is connected to the drive shaft 12, similar effects to the above described effects are obtained.

[0040] A variable displacement swash plate type compressor according to a second preferred embodiment of the present invention is also applied to a vehicle air conditioning system. In the compressor of the second embodiment, as shown in FIG. 4, a radial bearing 40 and a thrust bearing 50 whose rolling diameter is substantially equal to that of the radial bearing 40 are placed in place of the first bearing 10 of the first embodiment. The rolling diameter of the thrust bearing 50 is smaller than that of the thrust bearing 13. The radial bearing 40 is placed in the rear side of the shaft seal device 9. The thrust bearing 50 is placed in the front side of the coned disc spring 20. In the second embodiment, identical reference numerals to the first embodiment are applied to the same or corresponding members in the second embodiment and overlapped description is omitted.

[0041] In the above structured compressor, the thrust bearing 50 receives thrust force that is generated on the coned disc spring 20. The radial bearing 40 receives radial force caused by drive of the drive shaft 12.

[0042] If torque that is generated on the radial bearing 40 is T1 and torque that is generated on the thrust bearing 50 is T2, as mentioned above gross torque T gives the following equation:

$$T=T1+T2$$

$$=P \times \pi / 4 \times D^2 \times R1 \times (\mu 1 + \mu 2)$$

where both of rolling diameters of the radial bearing 40 and the thrust bearing 50 are R1.

[0043] Thus, even in the compressor of the second embodiment, gross torque T is restrained by shortening the rolling diameter of the thrust bearing 50 than that of the thrust bearing 13. Therefore, load that is applied to the drive shaft 12 is reduced. Thereby, power loss is reduced. Similar effects of the first embodiment are also obtained.

[0044] Therefore, the present examples and embodiments are to be considered as illustrative and not restrictive and the invention is not to be limited to the details given herein but may be modified within the scope

of the appended claims.

Claims

1. A variable displacement swash plate type compressor being used in connection with an external drive source and including a housing, a first bearing, a drive shaft, a lug plate, a swash plate, a hinge mechanism, a single-head piston and a control mechanism, the housing in which a cylinder bore, a crank chamber, a suction chamber and a discharge chamber are defined, the first bearing being accommodated on a front side of the housing, the drive shaft being supported by the first bearing in the housing rotatably, the lug plate being fixed to the drive shaft in the crank chamber, the swash plate being supported by the drive shaft in the crank chamber rotatably, the single-head piston being accommodated in the cylinder bore reciprocally and being connected to the swash plate so as to reciprocate in accordance with the rotation of the swash plate, the control mechanism communicating with the crank chamber, the suction chamber and the discharge chamber for controlling pressure in the crank chamber, **characterized in that** urging means is placed between the first bearing and the lug plate and has urging force for reducing thrust force applied to the first thrust bearing, and **in that** the first bearing receives radial force and thrust force.
2. The variable displacement swash plate type compressor according to claim 1, wherein the drive shaft is urged by a force based on the pressure in the crank chamber, the urging force being larger than a maximum value of the force based on the pressure in the crank chamber.
3. The variable displacement swash plate type compressor according to claim 1 or 2, wherein the first bearing is a tapered roller bearing.
4. The variable displacement swash plate type compressor according to any one of claims 1 through 3, wherein the first bearing has a race that is integrally rotated with the drive shaft, the urging means being a coned disc spring that is placed between the race and the lug plate.
5. The variable displacement swash plate type compressor according to any one of claims 1 through 4, wherein the race is an inner race, the first bearing further having an outer race and a plurality of rollers, the outer race being press-fitted into the housing, the rollers being interposed between the inner race and the outer race.
6. The variable displacement swash plate type com-

pressor according to claim 1 or 2, wherein the first bearing has a radial bearing and a second thrust bearing.

- 5 7. The variable displacement swash plate type compressor according to claim 6, wherein rolling diameter of the radial bearing is equal to that of the second thrust bearing.
- 10 8. The variable displacement swash plate type compressor according to one of any claims 1 through 8, wherein the drive shaft is continuously driven while the external drive source drives.
- 15 9. The variable displacement swash plate type compressor according to any one of claims 1 through 9, wherein the refrigerant gas is carbon dioxide.

20

25

30

35

40

45

50

55

FIG. 1

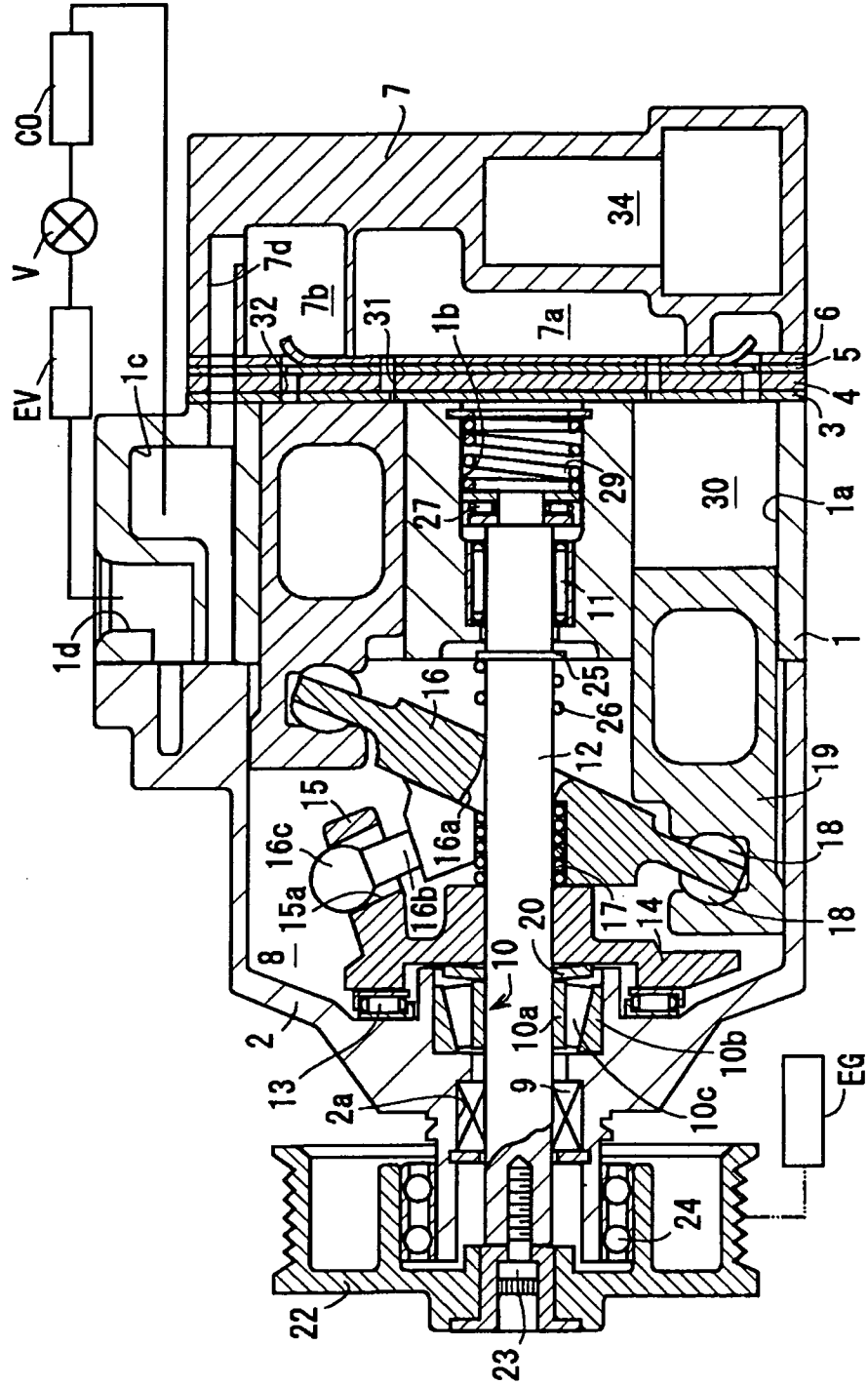

FIG. 2

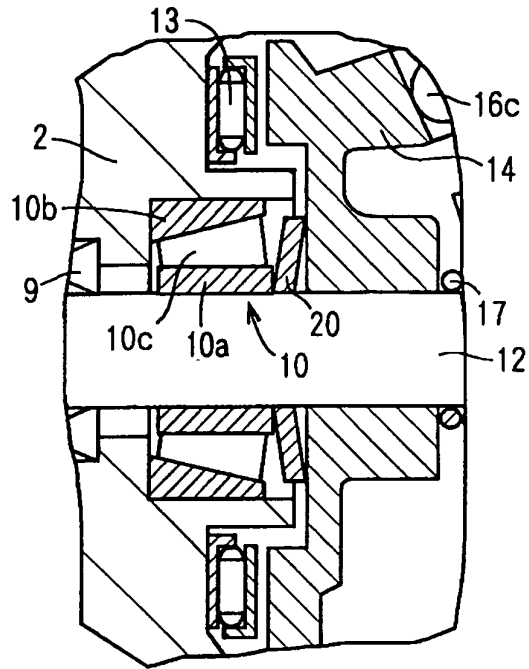

FIG. 3

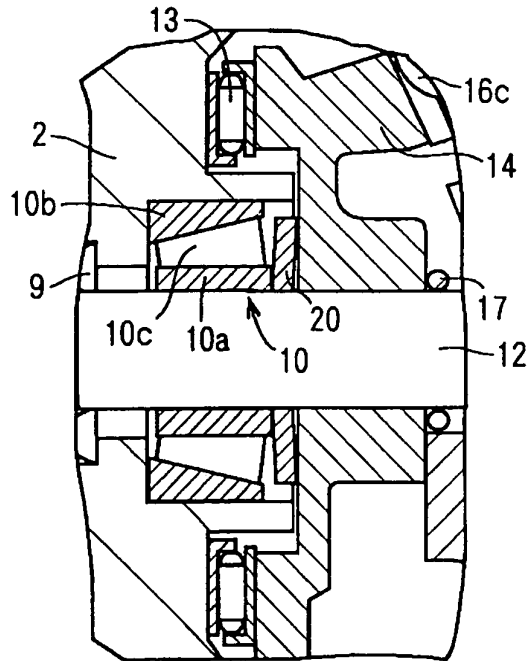

FIG. 4

