

INTERNATIONAL APPLICATION PUBLISHED UNDER THE PATENT COOPERATION TREATY (PCT)

(51) International Patent Classification ⁵ :

G11B 5/48

A1

(11) International Publication Number:

WO 92/09076

(43) International Publication Date:

29 May 1992 (29.05.92)

(21) International Application Number: PCT/US91/08371

(22) International Filing Date: 8 November 1991 (08.11.91)

(30) Priority data:

612,012

9 November 1990 (09.11.90) US

(71) Applicant: HUTCHINSON TECHNOLOGY, INC. [US/US]; 40 West Highland Park, Hutchinson, MN 55350-9784 (US).

(72) Inventors: BLAESER, David, J. ; 455 School Road North, Hutchinson, MN 55350-9784 (US). LIEN, Brent ; 628 Lynn Road, Hutchinson, MN 55350-9784 (US).

(74) Agent: STEFFEY, Charles, E.; Faegre & Benson, 2200 Norwest Center, 90 South Seventh Street, Minneapolis, MN 55402-3901 (US).

(81) Designated States: AT (European patent), BE (European patent), CA, CH (European patent), DE (European patent), DK (European patent), ES (European patent), FR (European patent), GB (European patent), GR (European patent), IT (European patent), JP, KR, LU (European patent), NL (European patent), SE (European patent).

Published*With international search report.*

(54) Title: IMPROVED MAGNETIC HEAD SUSPENSION

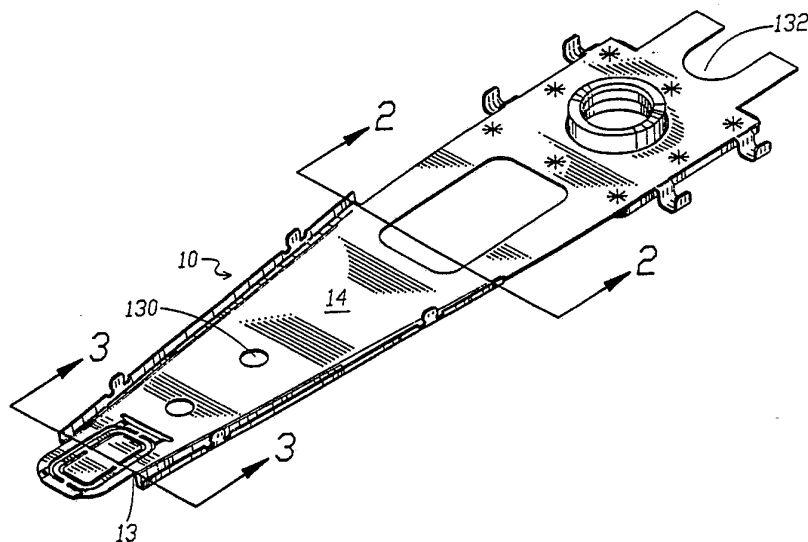

(57) Abstract

An improved magnetic head suspension having a unitary load beam (10) and flexure structure with a gimbal slider baseplate (12) etched into the slider. The present magnetic head suspension assembly overcomes prior art limitations by making the load beam (10) and flexure from one piece of sheet material. Thus, the accuracy of orientation of the flexure in relation to the load beam (10) is carefully controlled and the overall structure can be optimized to improve its dynamic characteristics and greatly reduce its size.

FOR THE PURPOSES OF INFORMATION ONLY

Codes used to identify States party to the PCT on the front pages of pamphlets publishing international applications under the PCT.

AT	Austria	ES	Spain	MG	Madagascar
AU	Australia	FI	Finland	ML	Mali
BB	Barbados	FR	France	MN	Mongolia
BE	Belgium	GA	Gabon	MR	Mauritania
BF	Burkina Faso	GB	United Kingdom	MW	Malawi
BG	Bulgaria	GN	Guinea	NL	Netherlands
BJ	Benin	GR	Greece	NO	Norway
BR	Brazil	HU	Hungary	PL	Poland
CA	Canada	IT	Italy	RO	Romania
CF	Central African Republic	JP	Japan	SD	Sudan
CG	Congo	KP	Democratic People's Republic of Korea	SE	Sweden
CH	Switzerland	KR	Republic of Korea	SN	Senegal
CI	Côte d'Ivoire	LI	Liechtenstein	SU ⁺	Soviet Union
CM	Cameroon	LK	Sri Lanka	TD	Chad
CS	Czechoslovakia	LU	Luxembourg	TG	Togo
DE*	Germany	MC	Monaco	US	United States of America
DK	Denmark				

⁺ Any designation of "SU" has effect in the Russian Federation. It is not yet known whether any such designation has effect in other States of the former Soviet Union.

IMPROVED MAGNETIC HEAD SUSPENSION

Background of the Invention

05 The present invention is an improved
magnetic head suspension (HSA) for use with dynamic
magnetic storage devices or rigid disk drives. More
specifically, it is a head suspension assembly (HSA)
that has improved gimbal, beam, and attachment
structures to improve dynamic performance of the HSA,
decrease pitch and roll stiffnesses, increase lateral
10 and in plane stiffnesses, improve manufacturability,
and improve head bond location.

Conventionally available magnetic head
suspension assemblies for rigid disk drives allow
magnetic read write heads to pitch about a first axis
15 and roll about a second axis orthogonal to the first
axis when imperfections in the disk drive assembly
tend to place the heads in improper positions. The
present invention is designed to allow significant
reductions in the pitch and roll stiffness of the
20 head suspension assembly, thus allowing the heads to
easily maintain proper attitude. At the same time,
the present invention is designed to increase the
stiffness in the direction of rotation to maintain
proper head position with respect to the suspension

- 2 -

assembly. Further, the invention is designed to resist permanent distortion caused by forces in all directions.

05 Conventional head suspension assemblies consist of a head support baseplate, load beam, and flexure which are usually etched, stamped and then welded together. The present invention is designed to allow the flexure and/or the baseplate to be an integral part of the load beam, which reduces
10 manufacturing steps and improves the ability to manufacture the head suspension with the proper head position and attitude.

15 Conventional head suspension attachments or base plates are welded to the load beam and attached to an actuator arm and are generally configured for swage or screw attachment. The present invention allows the attachment to be an integral part of the load beam and not welded, which reduces process steps, eases disk drive assembly, and
20 improves the ability to position the head properly with respect to the actuator arm. The present invention attaches to the actuator arm by an attachment means employing an interference fit such as a clip.

25 Another embodiment of the present invention is designed to attach the load beam to the actuator arm by a shrink fit interference means encircling the arm and load beam(s). Such a shrink fit could be performed by heating the attachment means to expand
30 and then contract or heating the attachment to simply contract it around the arm and load beam(s), which reduces the number of components and process steps and allows the head suspension assembly to be attached and removed from the actuator arm easily.

- 3 -

Conventional means for positioning and aligning the read write head to the suspension assembly when attaching the head suspension assembly to the actuator arm when attaching it to place a pin through a hole in the load beam, a pin through a hole(s) in the baseplate, and mount the baseplate on the arm with screws or with the baseplate boss. The present invention is designed to improve the accuracy and ease of positioning the head with respect to the suspension assembly and to facilitate the alignment of the head suspension assembly with respect to the actuator arm by using a pin through a hole in the load beam and a pin through a slot at the base end. The pin/hole registration will keep the part aligned in the x and y directions while the pin/slot registration keeps the part from rotating about the z axis. Further, a unitary suspension piece eliminates the tolerance build up from welding three components together and allows the head location to depend solely on the precision manufacture of the holes and slots.

Conventionally available magnetic head suspension assemblies have load beams with rails formed away from the rigid disk or toward the rigid disk, as shown in commonly assigned application serial no. 07/583,048 and with a form line that is generally parallel to the disk surface.

In the prior art, the conventional rail formed to project from the surface of the load beam which is oriented away from the disk offered increased clearance between the disk and the load beam for lifting the load beam, while the conventional rail oriented toward the disk surface offered increased clearance between two back to back

- 4 -

head suspension assemblies and allows for closer disk spacing. The present invention is designed to offer increased clearance on both sides of the head suspension assembly for lifting the load beam and allowing closer disk spacing. The invention uses a rail form line that is not parallel to the disk surface but is closer to the disk at the slider end and away from the disk at the base end such that the lift clearance can be maximized near the base and the disk spacing clearance can be maximized near the slider.

Brief Description of the Invention

The magnetic head suspension assembly of the present invention overcomes the limitations of the prior art by making the load beam and flexure from the same piece of sheet material. In so doing the accuracy of orientation of the flexure in relation to the load beam is carefully controlled and the overall structure can be optimized to improve its dynamic characteristics and greatly reduce its size.

More specifically, the suspension assembly of the present invention includes a spring load beam element portion joined to the arm at a proximal end thereof; a unitary flexure portion projecting beyond the distal apex of the element, the flexure portion being divided into a head support area constructed and arranged for receiving a disk drive head to be bonded thereto; and at least two flexible arms defined by slots in the surface of the flexure portion where the slots also define a perimeter of the head support and where each of the arms generally encloses at least a portion of the perimeter of the head support and each of the flexible arms is constructed and arranged for flexible suspension of

- 5 -

the head support.

It is an object of the present invention to provide an improved magnetic head suspension having a unitary load beam and flexure structure.

05 It is also an object of the present invention to provide a flexure having reduced flexure pitch and roll stiffness and increased lateral or rotary stiffness

10 Another object of the present invention is to provide a head suspension and actuator arm attachment that fixes the load beam to the actuator arm and is easy to attach, easy to rework, and can reduce manufacturing costs.

15 A further object of the present invention is to provide a load beam with increased clearance between itself and the rigid disk, increased clearance on the opposing side to reduce disk spacing or total rigid disk drive spacing, improved resonance, and lowered spring rate.

20 A still further object of the present invention is to provide locating aids or tooling indices to more accurately locate the read write head with respect to the suspension assembly and the suspension assembly and read write head more accurately with respect to the actuator arm.

25 These and other objects of the present invention will be apparent with reference to the drawings, the description of the preferred embodiment, and the claims.

30 Brief Description of the Drawings

Figure 1 is a top perspective view of the magnetic head suspension in accordance with this invention;

Figure 2 is a sectional view of the load

- 6 -

beam in Figure 1 with the sectional through the rails near the spring area;

05 Figure 3 is a sectional view of the distal end of the assembly in Figure 1 with the section taken through the flexure which is an integral part of the load beam;

Figure 4 is a top perspective detail view of the flexure portion of the suspension in Figure 1;

10 Figure 5 is a top perspective view of another magnetic head suspension assembly in accordance with this invention;

Figure 6 is a top perspective detail view of the flexure portion of the suspension assembly in Figure 5;

15 Figure 7 is a top perspective view of a load beam to actuator arm attachment that is in accordance with this invention; and

20 Figure 8 is a perspective view of another load beam to actuator attachment concept that is in accordance with this invention.

Description of the Preferred Embodiment

25 The improved flexure and load beam structure for use in an improved magnetic head suspension which is illustrated in Figures 1-4, consists of a head support baseplate means or central head support area 12 which projects beyond a distal apex 13 of a spring load beam element 14. The head support area 12 is where the slider, the element which supports the read-write head, is to be bonded to the flexure.

30 Load beam element 14 has provisions at its proximal end 15 for attachment to a disk drive rigid actuator arm which is not illustrated. In the embodiment shown in Figure 1, a swaging boss 16 is provided for forming a swaged connection to an

- 7 -

actuator arm or E-Block utilizing well known swaging techniques. Alternatively, load beam element 14 may be secured to the arm using bolts, any other commonly used attachment means or the improved attachment means disclosed in Figures 7 and 8 and discussed below.

In the preferred embodiment shown in Figs. 1 through 4, the head support means 12 is formed integrally with the flexure and load beam structure 10 rather than being formed as a separate structure which is then welded to the load beam as shown, for example, in the prior art Watrous patent and a number of subsequent patents. In the preferred embodiment according to the present invention, the integral flexure structure is formed by etching a number of apertures or slots 18, 20, 22, 24 in the vicinity of the distal apex 13 of the load beam element 14 in order to form a plurality of flexible arms 26 and 28 which provide low stiffness in the pitch and roll axes to allow head support means 12 to move freely about those axes while providing high translational stiffness to keep the head mounted on head support means 12 from moving to side to side or front to back as the actuator moves the slider across the face of the disc.

Referring to the detail shown in Fig. 4 of the flexure portion of load beam element 14, it can be seen that slots 22 and 24 which enclose at least a portion of the perimeter of head support means 12 leave only connecting arms 30 between the edges of head support means 12 and the remainder of the flexure and load beam structure 10 such that the head support means is relatively freely pivotable about a first axis drawn through the arms 30 which connect

- 8 -

head support means 12 to flexible arms 26 and 28 which are themselves interconnected to the body of load beam element 14 by connecting arms 32 which, when interconnected by a second axis drawn through them, suspend head support means 12 and flexible arms 26 and 28 about the second axis which is orthogonal to the first axis. The first axis can generally be referred to as a pitch axis while the second axis can be referred to as a roll axis. As shown specifically in the detail in Fig. 4, it can be seen that offsets 36 and 38 are formed in the surface of the flexure portion of the spring load beam element 14 to provide clearance for a head mounted on the head support means by vertically adjusting its position relative to the surface of spring load beam element 14. Offsets 36 and 38 can be formed by either etching, stamping or similar processes. The cross-sectional view of the central head support area 12 shown in Fig. 3 illustrates that head support means 12 is depressed below the surface of load beam element 14 by an offset h1. Fig. 3 also illustrates that the head support means 12 can be etched to make it thinner to reduce its weight and also change its dynamic characteristics.

By forming the flexure as an integral part of load beam 14, the error build-up which arises from the process of mounting a separate flexure portion on the load beam element is eliminated. The partial etching to thin areas of the flexure such as the flexible arms allows for the achievement of lower pitch and roll stiffnesses while maintaining standard strength characteristics in the remainder of the integral load beam 14.

Also illustrated in Figs. 1 through 4 is a

stiffening rail structure which differs substantially from load beam reinforcement arrangements normally found in prior art slider suspensions. At the distal apex of the suspension, it can be seen that the edge of the load beam is bent downwardly about a first radius 40 and then bent about radii 42 and 44 to form a channel which has its edge 46 terminate generally in the plane of the surface of load beam element 14 as can be clearly seen in Fig. 3.

The channels at the edges of load beam 14 have a depth h_2 at the distal end of load beam element 14. The depth decreases along the length of the load beam moving toward the proximal end until there is no offset h_1 of the bottom of the channel from the surface of load beam 14 at the point where the rails terminate in the vicinity of section line 2 as shown in Fig. 1. Thus the channels along the sides of the load beam element 14 are level with the surface of load beam 14 at a point approaching the distal end of the load beam and the bottom of the channels are level with the flat area at the proximal end of the channel. The rail arrangement provides increased loading clearance for a suspension by minimizing the height at the distal end and allowing increased to disc to suspension clearance at the proximal end to facilitate lifting of the head slider and proximal end of the load beam to displace the head from the surface of the disc.

Fig. 5 shows a further embodiment of the present invention. The flexure and load beam structure 10 is divided into an upper load beam element 60 and a lower load beam element 62 which are positioned for engaging the top and bottom surfaces of an actuator arm 64. As shown in Fig. 5, a

- 10 -

projecting attachment means 66 from the upper load
beam element 60 interfaces with a cooperating
attachment means 68 projecting from the side of lower
load beam element 62. Upper attachment means 66 is
05 L-shaped and provides for a spring-loaded interface
with lower attachment means 68 which projects
outwardly from the surface of lower load beam element
62 and has a vertically projecting tab 70 which has a
horizontal projection 72 which engages the attachment
10 means connected to upper load beam element 60.
Finally, a latch segment 74 is formed by forming a
large radius in the portion of element 72 from its
distal terminus to a point slightly beyond the width
of tab 66 of upper attachment means 68 to make a
15 positive fit when the attachment means 66 and 68 are
pushed together as the suspension is assembled to the
actuator arm 64.

At the proximal end of the two-piece
suspension shown in Fig. 5, an integral flexure is
20 again illustrated. The central head support area or
head support means 76 is shown. The perimeter of
head support means 76 is defined by slot 78 and 80.
Additional slots 82 and 84 serve to define elongated,
bent flexible arms 86 and 88 which extend from a
25 point 90 at the main body of load beam 60 and extend
along the perimeter of head support means 76 bend at
approximately a right angle at point 92 and then
intersect with a corner of the head support means
76. In the same manner, flexible arms 94 also
30 project from the main body of the load beam element
60 and join opposite adjacent corners of head support
means 76 to provide for gimbal support of the head
support means 76. Again, the head support means 76
is freely movable in the pitch and roll rotational

- 11 -

axes while providing high translational stiffness to keep the head from moving from side to side or front to back.

05 Although one form of slot pattern for forming the flexible arms and central head support means as shown in Figs. 1 through 4 and a different form is shown for the two-piece suspension shown in Figs. 5 and 6, the arrangements are, in fact, interchangeable and the embodiment of the etching
10 pattern shown in Figs. 5 and 6 can be used on the single piece suspension shown in Figs. 1 through 4 or the etching pattern shown in Figs. 1 through 4 can equally well be used on the two-piece suspension illustrated in Figs. 5 and 6.

15 As alternatives to the swaged attachment of the load beam to the actuator arm illustrated in the embodiment shown in Figs. 1 through 4 and the integral attachment means shown in the embodiment shown in Figs. 5 and 6, Figs. 7 and 8 show two
20 alternative attachment means for connecting load beams 100 and 102 respectively to actuator arms 104 and 106 respectively. In Fig. 7, a C-shaped clip 108 slides over and urges load beam 100 into attachment with actuator 104. The clip 108 can be welded to
25 load beam 100 before mounting or can be formed as an integral part of the load beam.

 In Fig. 8, a band 110 is wrapped around an actuator arm 106 sandwiching either a single piece load beam structure 102 as shown or upper and lower
30 structures of the type shown in Figs. 5 and 6. Band 110 must be larger than the total circumference of the actuator arm 106 and the load beam 102 when slipped in place and is then shrunk down to create an interference fit between the arm and load beams. If

- 12 -

formed from memory metal, the band is heated to expand it for fitting and then allowed to contract. The band can also be made from plastic or similar material which is heated and caused to shrink and permanently deform to secure the load beam 102 to actuator arm 106.

Conventional means for positioning and aligning the slider with respect to the head support base plate included the insertion of tooling pins through a first hole in the flat portion of the load beam and through a second hole in the base portion of the load beam in the vicinity of the swaging boss. Since the location of the slider using that arrangement was dependant on tolerances between the flexure and load beam, load beam and base plate, manufacture of the base plate, and manufacture of the flexure; the location of the slider was not as accurate as required for some applications. One other prior art locating concept consists of inserting tooling pins through a hole and slot which are located in the load beam flat area. Because the distance between the hole and slots as used in prior art devices was small, the location accuracy was not sufficient for all purposes.

The improved fixturing or locating system according to the present invention consists of a first tooling pin through a hole 130 in the load beam very near the flexure and a second tooling pin through a slot 132 in the load beam at the very end opposite the flexure. With the hole and slot being substantially displaced from each other, and the flexure integrated into the load beam, locating tolerances are much improved.

Prior art location of sliders with respect

- 13 -

to each other in a actuator stack was determined by a
pin through each hole in their respective load
beams. The improved fixturing system usable with the
unitary load beam and flexure structure has a hole
05 120 (Figure 8) very near the flexure to minimize
misalignment of sliders mounted on the flexure
baseplates.

10

15

20

25

30

- 14 -

What Is Claimed Is:

1. A magnetic head suspension for attachment to a rigid arm, said head suspension comprising, in combination:

- (a) a spring load beam element portion joined to the arm at a proximal end thereof;
- (b) a unitary flexure portion projecting beyond the distal apex of the element, the flexure portion being divided into head support means constructed and arranged for receiving a disk drive head to be bonded thereto; and
at least two flexible arms defined by slots in the surface of the flexure portion, said slots also defining a perimeter of the head support means, each of the arms generally enclosing at least a portion of the perimeter of the head support means, each of the flexible arms being constructed and arranged for flexible suspension of the head support means.

2. The invention of claim 1 wherein the load beam element portion and the flexure portion are separate pieces welded to each other.

3. The invention of claim 1 wherein the magnetic head suspension is unitary and the load beam element portion and the flexure portion are formed

from a single piece of sheet material.

4. The invention of claim 1 wherein at least some of the flexible arms have at least one bend along their length

5. In a magnetic head suspension for supporting a magnetic head at a fixed distance from a rigid arm, a unitary flexure and load beam comprising:

- (a) a spring load beam element portion joined to the arm at a proximal end thereof; and
- (b) a unitary flexure portion projecting beyond the distal apex of the element, the flexure portion being divided into

a head support means constructed and arranged for receiving a disk drive head to be bonded thereto; and

at least a pair of flexible arms generally enclosing and supporting the central head support means, a first pair of the arms formed by etching elongated slots generally parallel to a first axis and a second pair of the slots formed by etching elongated slots generally parallel to a second axis, the flexure arm portions cooperating to provide gimbal support for the head support means.

6. The invention of Claim 5 wherein the first

- 16 -

axis is the longitudinal axis of the load beam element and the second axis is perpendicular to the first axis and in the same plane as the head support means.

7. In a magnetic head suspension for supporting a magnetic head at a fixed distance from a rigid arm, a unitary flexure and load beam formed from a single sheet of material, said suspension comprising:

- (a) a spring load beam element portion joined to the arm at a proximal end thereof; and
- (b) a unitary flexure portion projecting beyond the distal apex of the element, the flexure portion being divided into a central head mounting support means for receiving a disk drive head to be bonded thereto; a first plurality of slots in the surface of the flexure portion around substantially the entire perimeter of the support means with the exception of two gimbal support pivot points aligned on opposite sides of the support means to define a first set of flexible arms for gimbal supporting the support means about a first rotational axis of the support means; and a second pair of slots in the surface of the flexure portion around substantially the entire perimeter of the support means and

- 17 -

the first plurality of slots with the exception of two gimbal support pivot points aligned on opposite sides of the support means to define a first set of flexible arms for gimbal supporting the support means about a second rotational axis of the support means which is angularly offset from the first rotational axis.

8. The flexure of claim 7 wherein the support means has an arcuate perimeter and a plurality of arcuate slots define a plurality of flexure arms for gimbaling the support means from a plurality of support points about its perimeter for movement relative to the load beam element.

9. The invention of claim 7 wherein the slots are formed as the flexure is manufactured by etching them and wherein at least some of the flexible arms are partially etched to thin them and reduce the spring rate of the arms.

10. In a magnetic head suspension for supporting a magnetic head at a fixed distance from a rigid arm, a unitary flexure and load beam formed from a single sheet of material, said suspension comprising:

- (a) a spring load beam element portion joined to the arm at a proximal end thereof; and
- (b) a unitary flexure portion projecting beyond the distal apex of the element,

- 18 -

the flexure portion being divided into a generally rectangular central head mounting support means for receiving a disk drive head to be bonded thereto; a plurality of slots in the surface of the flexure portion to define four flexible arms, each of which has its longitudinal axis oriented generally parallel to an adjacent side of the support means, terminated at one end at the flexure means and joined at the other end to a corner of the support means, each of the flexible arms bent perpendicular to its longitudinal axis adjacent the corner of the support means for suspending the support means for gimballed movement relative to the load beam element.

11. The flexure of claim 10 wherein the head support area is generally square and the gimballed support pivot points are located at approximately the midpoints of the sides of the head support area.

12. The flexure in claim 1, 5 or 7 wherein the slots of at least one of the pairs of flexure arms are generally circular.

13. The flexure of claim 1, 5 or 7 wherein the first and second pairs of flexure arms are of substantially equal length to thereby provide gimballed support to the

- 19 -

central area with stiffness in the longitudinal and transverse axes being substantially equal.

14. The flexure in claim 1 or 5 or 7 wherein the flexure arms overlap each other to increase their length.

15. In a magnetic head suspension for supporting a magnetic head at a fixed distance from a rigid arm, a unitary flexure and load beam formed from a single sheet of material, said suspension comprising:

- (a) a spring load beam element portion joined to the arm at a proximal end thereof; and
- (b) a unitary flexure portion projecting beyond the distal apex of the element, the flexure portion being divided into a central head mounting support means for receiving a disk drive head to be bonded thereto; a plurality of slots in the surface of the flexure portion to define at least two extended flexible arms each of which is terminated at one end to equally spaced intersection points about the perimeter of the support means for suspending the support means for gimballed movement relative to the load beam element.

16. The flexure in claim 15 wherein the flexible arms are generally circular or arcs.

- 20 -

17. The flexure in claim 15 wherein the flexure arms are generally straight and at right angles to form a box.

18. The flexure in claim 15 wherein the flexure arms overlap each other to increase their length.

19. In a magnetic disk drive having a magnetic head suspension for supporting a magnetic head at a fixed distance from an actuator arm, said suspension including a flexure and load beam, an improved attachment means for affixing the load beam to the rigid arm, said attachment means comprising: a band of shrinkable material which at least partially encircles the rigid arm and the proximal portion of the load beam and is shrunk into place after positioning thereby affixing the load beam to the arm.

20. A method for securing a proximal end of a load beam to an actuator arm comprising the steps of:
positioning the proximal end of the load beam and the actuator arm in the desired position;
at least partially encircling the actuator and load beam with a band of shrinkable material; and
shrinking the band of material to affix the load beam to the arm.

21. The attachment in claim 19 wherein the head suspension has upper and lower load beam portions attached to opposite faces of an actuator arm.

22. A magnetic head suspension for attachment to a rigid arm, said head suspension comprising, in combination:

- (a) load beam element portion joined to the arm at the proximal end of thereof, said load beam element having bendable integral projecting locking elements for securing it to interfitting slots in the rigid arm when it is positioned against the rigid arm and the locking elements are bent into the interfitting slots.

23. The attachment in claim 19 wherein the material is memory metal.

24. The attachment in claim 19 wherein the material is plastic or some similar material that shrinks at elevated temperatures and retains the shrunken condition when the temperature is returned to ambient conditions.

25. In a magnetic disk drive having a magnetic head suspension for supporting a magnetic head at a fixed distance from an actuator arm, said suspension including a flexure and load beam, an improved attachment means for affixing the load beam to the rigid arm, wherein said attachment means is an integral part of and unitary with the load beam, and wherein the attachment portion is formed such that it will clip onto an actuator arm and fix itself in place via an interference fit.

26. A method for using locating tooling with respect to a head suspension assembly for rigid disk

- 22 -

drives that has a load beam with a slot at its proximal end and a hole near its distal end, said method comprising the steps of placing a first locating pin in said hole to keep the suspension from translating in x and y directions, placing a second locating pin in the slot to keep the suspension from rotating about a z direction where the slot is placed at the proximal end of the suspension to maximize the distance between the said slot and said hole thereby minimizing undesired movement of the suspension.

27. The system in claim 26 wherein there are more than one hole in the load beam.

28. A suspension load beam for a rigid disk drive, said load beam comprising a generally flat central load beam area having channels disposed along the sides of the said flat area wherein the top of the channels are level with the flat area at the load beam distal end and the bottom of the channels are level with the flat area at the proximal end such that the distal end provides increased loading clearance and the proximal end provides increased disk to suspension clearance thereby facilitating the lifting of the proximal end of the beam.

29. The suspension load beam in claim 28 wherein the channels are parallel to each other.

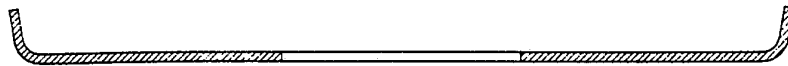
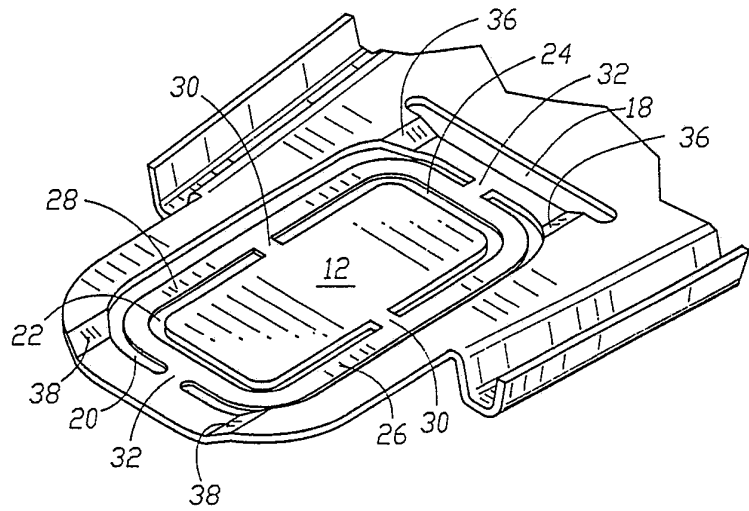
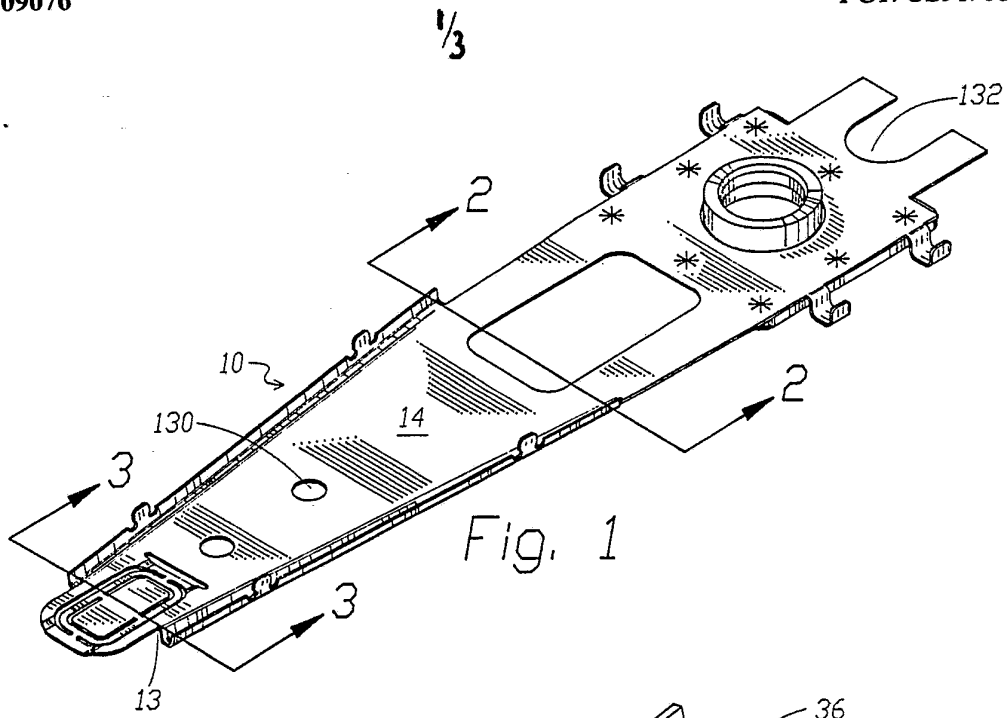
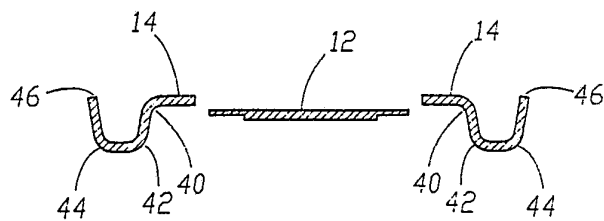

Fig. 2



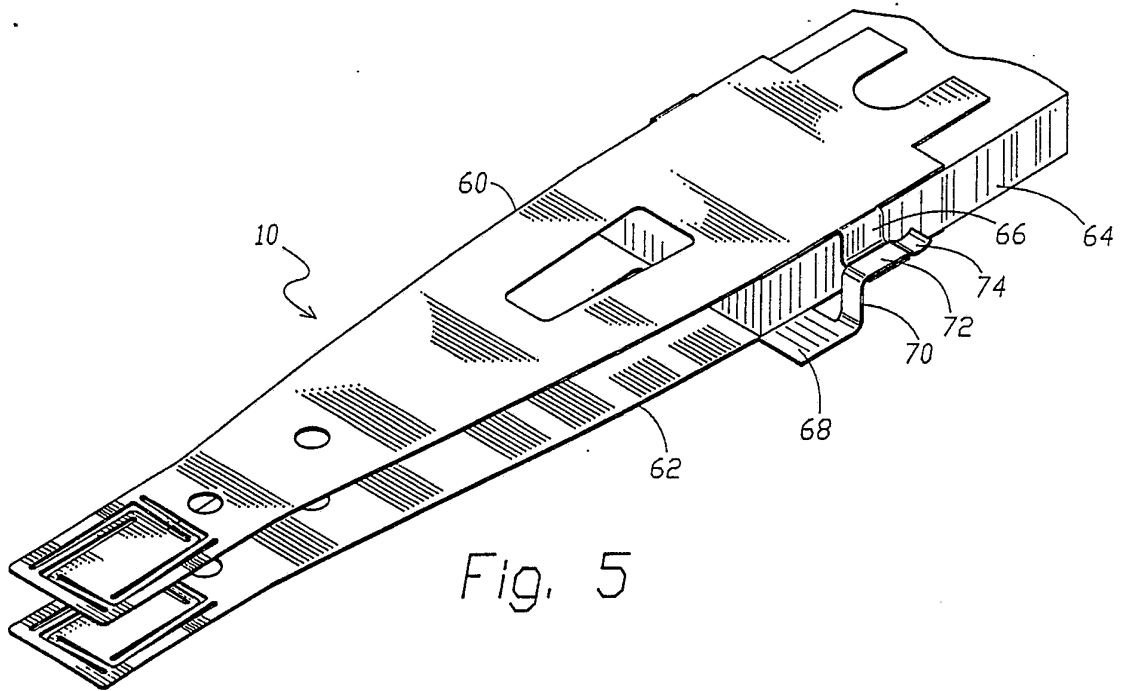

Fig. 5

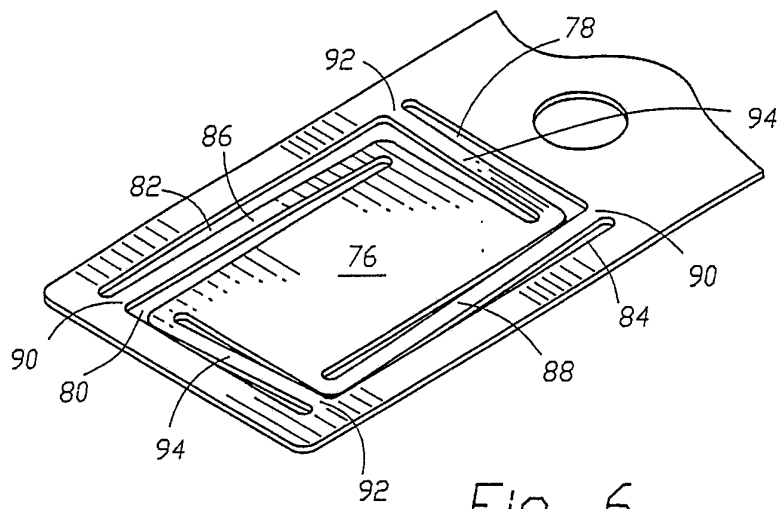

Fig. 6

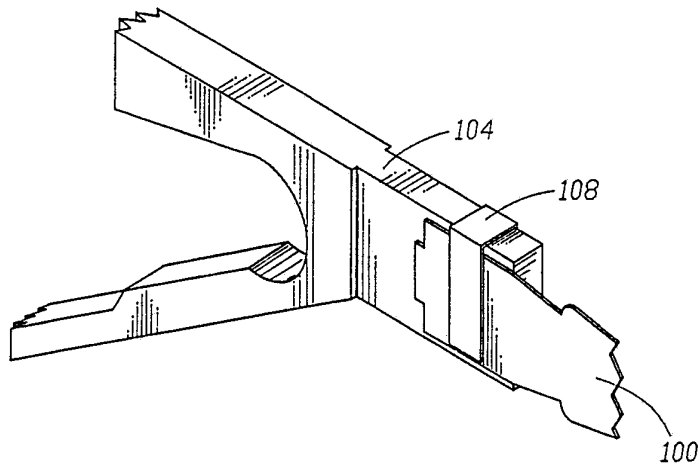

Fig. 7

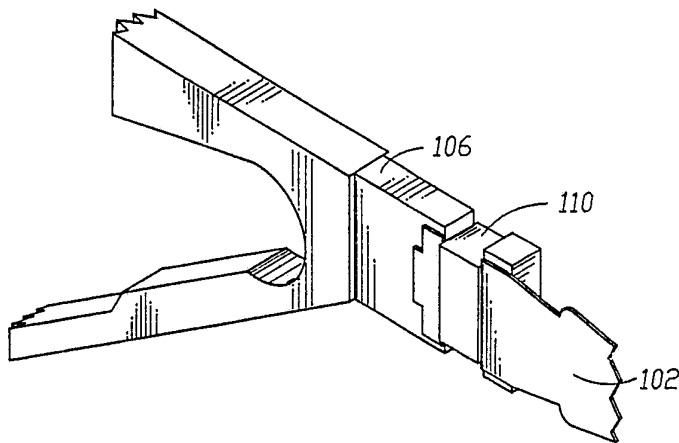

Fig. 8

INTERNATIONAL SEARCH REPORT

International Application No. PCT/US91/08371

I. CLASSIFICATION OF SUBJECT MATTER (if several classification symbols apply, indicate all) ⁶		
According to International Patent Classification (IPC) or to both National Classification and IPC		
IPC (5): G11B 5/48		
U.S.CI.: 360/104		
II. FIELDS SEARCHED		
Minimum Documentation Searched ⁷		
Classification System	Classification Symbols	
U.S.CI.	360/104	
Documentation Searched other than Minimum Documentation to the Extent that such Documents are Included in the Fields Searched ⁸		
III. DOCUMENTS CONSIDERED TO BE RELEVANT ⁹		
Category ⁹	Citation of Document, ¹¹ with indication, where appropriate, of the relevant passages ¹²	Relevant to Claim No. ¹³
X	US, A, 4,853,813 (YAMANOUCI) 01 August 1989 Notes elements 16 (gimble) and 30 (loadbeam)	1-18
X	US, A, 4,943,875 (REIDENBACH) 24 July 1990 See Figs. 4 and 5.	22 & 25
X	US, A, 4,853,811 (BROOKS) 01 August 1989 See column 4, lines 28-49.	26 & 27
<p>¹⁰ Special categories of cited documents:</p> <p>"A" document defining the general state of the art which is not considered to be of particular relevance</p> <p>"E" earlier document but published on or after the international filing date</p> <p>"L" document which may throw doubts on priority claim(s) or which is cited to establish the publication date of another citation or other special reason (as specified)</p> <p>"O" document referring to an oral disclosure, use, exhibition or other means</p> <p>"P" document published prior to the international filing date but later than the priority date claimed</p> <p>"T" later document published after the international filing date or priority date and not in conflict with the application but cited to understand the principle or theory underlying the invention</p> <p>"X" document of particular relevance; the claimed invention cannot be considered novel or cannot be considered to involve an inventive step</p> <p>"Y" document of particular relevance; the claimed invention cannot be considered to involve an inventive step when the document is combined with one or more other such documents, such combination being obvious to a person skilled in the art.</p> <p>"&" document member of the same patent family</p>		
IV. CERTIFICATION		
Date of the Actual Completion of the International Search		Date of Mailing of this International Search Report
08 January 1992		21 FEB 1992
International Searching Authority		Signature of Authorized Officer
ISA/US		<i>A. J. Heinz</i> A. J. Heinz