



(86) Date de dépôt PCT/PCT Filing Date: 2000/03/13
 (87) Date publication PCT/PCT Publication Date: 2000/11/02
 (45) Date de délivrance/Issue Date: 2010/06/01
 (85) Entrée phase nationale/National Entry: 2001/10/22
 (86) N° demande PCT/PCT Application No.: EP 2000/002216
 (87) N° publication PCT/PCT Publication No.: 2000/064558
 (30) Priorité/Priority: 1999/04/22 (US09/296,975)

(51) Cl.Int./Int.Cl. *B01D 33/03* (2006.01),
B07B 1/46 (2006.01)

(72) Inventeurs/Inventors:
 ADAMS, THOMAS COLE, US;
 SEYFFERT, KENNETH WAYNE, US;
 LARGENT, DAVID WAYNE, US;
 SCHULTE, DAVID LEE, US;
 MCCLUNG, GUY LAMONT III, US;
 WALKER, JEFFREY EARL, US;
 MURRAY, HECTOR M., US;

(73) Propriétaire/Owner:
 VARCO I/P INC., US

(74) Agent: MCFADDEN, FINCHAM

(54) Titre : ENSEMBLE TAMIS, SEPARATEUR VIBRANT ET PROCEDE DE CRIBLAGE
 (54) Title: SCREEN ASSEMBLY, VIBRATORY SEPARATOR AND METHOD OF SCREENING

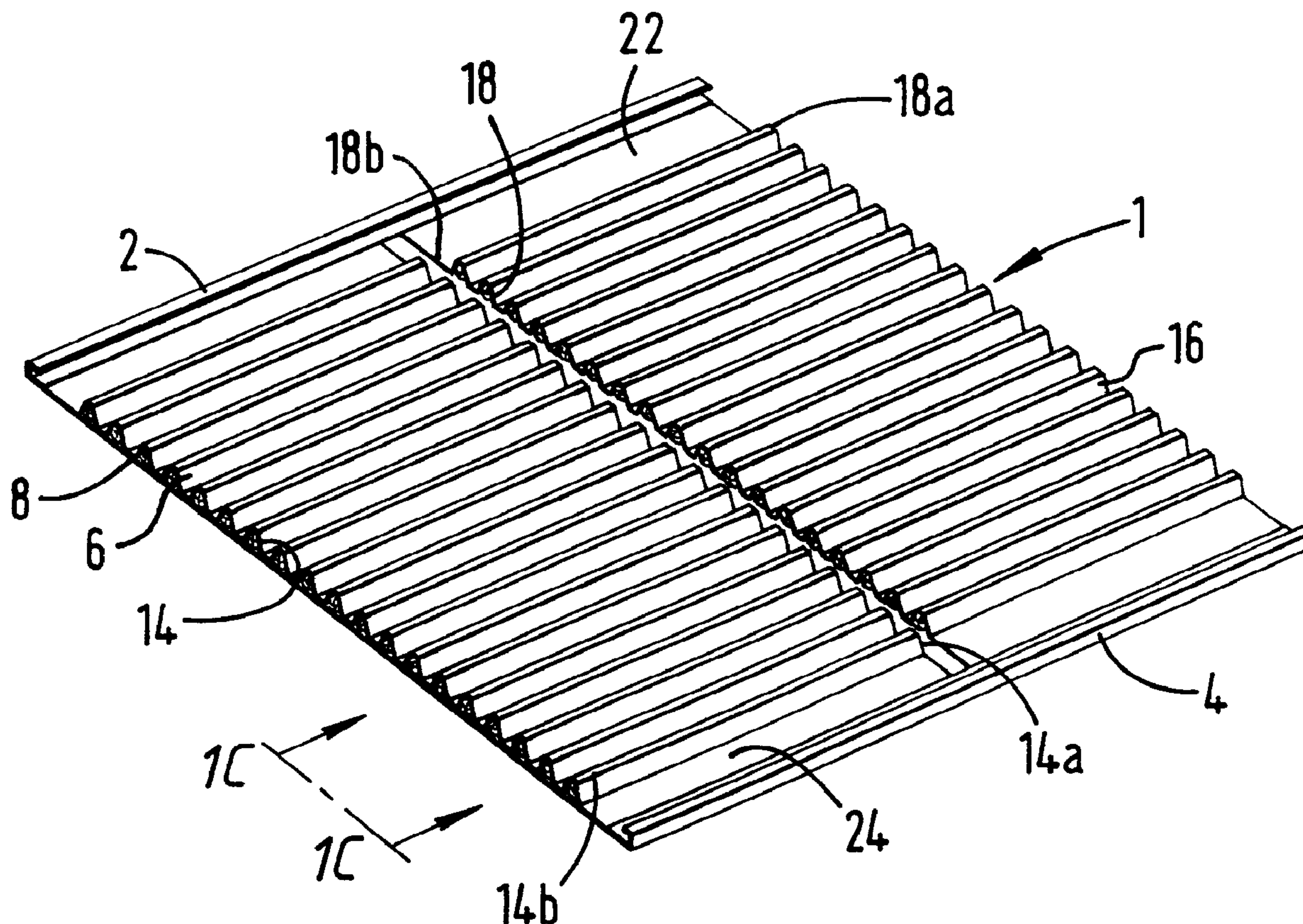

(57) Abrégé/Abstract:

A screen assembly for a vibratory separator, the screen assembly comprising at least two ridge-valley series of screening material (14, 16) each of which comprises a plurality of alternating ridges (18) and valleys (20) of screening material, wherein at least one of

(72) **Inventeurs(suite)/Inventors(continued)**: MARONEY, JAMES FRANCIS III, US; WINKLER, JOSEPH CHARLES, US

(57) **Abrégé(suite)/Abstract(continued)**:

the ridge-valley series of screening material (14) is offset from at least one other ridge-valley series of screening material (16). A screen comprising screening material (43) formed with ridges characterised in that said ridges are of at least two different sizes. A screen comprising screening material having a plurality of ridges and at least two sides, characterised in that said ridges are arranged at an acute angle to one of said sides. A screen comprising screening material having at least one elongate ridge and valley, characterised in that said ridge differs in shape therealong. Vibratory separators provided with a screen of the invention and methods of using same.

**PCT**WORLD INTELLECTUAL PROPERTY ORGANIZATION
International Bureau

INTERNATIONAL APPLICATION PUBLISHED UNDER THE PATENT COOPERATION TREATY (PCT)

<p>(51) International Patent Classification ⁷ : B01D 33/03, B07B 1/46</p>	<p>A1</p>	<p>(11) International Publication Number: WO 00/64558</p> <p>(43) International Publication Date: 2 November 2000 (02.11.00)</p>
<p>(21) International Application Number: PCT/EP00/02216</p> <p>(22) International Filing Date: 13 March 2000 (13.03.00)</p> <p>(30) Priority Data: 09/296,975 22 April 1999 (22.04.99) US</p> <p>(71) Applicants: TUBOSCOPE I/P INC. [US/US]; 2835 Holmes Road, Houston, TX 77051 (US). LUCAS, Brian, Ronald [GB/GB]; Lucas & Co., 135 Westhall Road, Warlingham, Surrey CR6 9HJ (GB).</p> <p>(72) Inventors: ADAMS, Thomas, Cole; Route 1, Box 538, Hockley, TX 77447 (US). SEYFFERT, Kenneth, Wayne; 1019 LaMonte Lane, Houston, TX 77018 (US). LARGENT, David, Wayne; Route 4, Box 1017M, Cleveland, TX 77327 (US). SCHULTE, David, Lee; 101 Antietam Avenue, Broussard, LA 70518 (US). MCCLUNG, Guy, Lamont, III; 8130 Vintage Creek, Spring, TX 77379 (US). WALKER, Jeffrey, Earl; 107 Valleyview, Lafayette, LA 70501 (US). MURRAY, Hector, M.; 7027 Gentle Breeze Drive, Willis, TX 77378 (US). MARONEY, James, Francis, III; 14807 River Forest Drive, Houston, TX 77079 (US). WINKLER, Joseph, Charles; 635 Lommead, Houston, TX 77024 (US).</p>	<p>(74) Agent: LUCAS, Brian, Ronald; Lucas & Co., 135 Westhall Road, Warlingham, Surrey CR6 9HJ (GB).</p> <p>(81) Designated States: AE, AL, AM, AT, AU, AZ, BA, BB, BG, BR, BY, CA, CH, CN, CR, CU, CZ, DE, DK, DM, EE, ES, FI, GB, GD, GE, GH, GM, HR, HU, ID, IL, IN, IS, JP, KE, KG, KP, KR, KZ, LC, LK, LR, LS, LT, LU, LV, MA, MD, MG, MK, MN, MW, MX, NO, NZ, PL, PT, RO, RU, SD, SE, SG, SI, SK, SL, TJ, TM, TR, TT, TZ, UA, UG, UZ, VN, YU, ZA, ZW, ARIPO patent (GH, GM, KE, LS, MW, SD, SL, SZ, TZ, UG, ZW), Eurasian patent (AM, AZ, BY, KG, KZ, MD, RU, TJ, TM), European patent (AT, BE, CH, CY, DE, DK, ES, FI, FR, GB, GR, IE, IT, LU, MC, NL, PT, SE), OAPI patent (BF, BJ, CF, CG, CI, CM, GA, GN, GW, ML, MR, NE, SN, TD, TG).</p> <p>Published <i>With international search report.</i></p>	

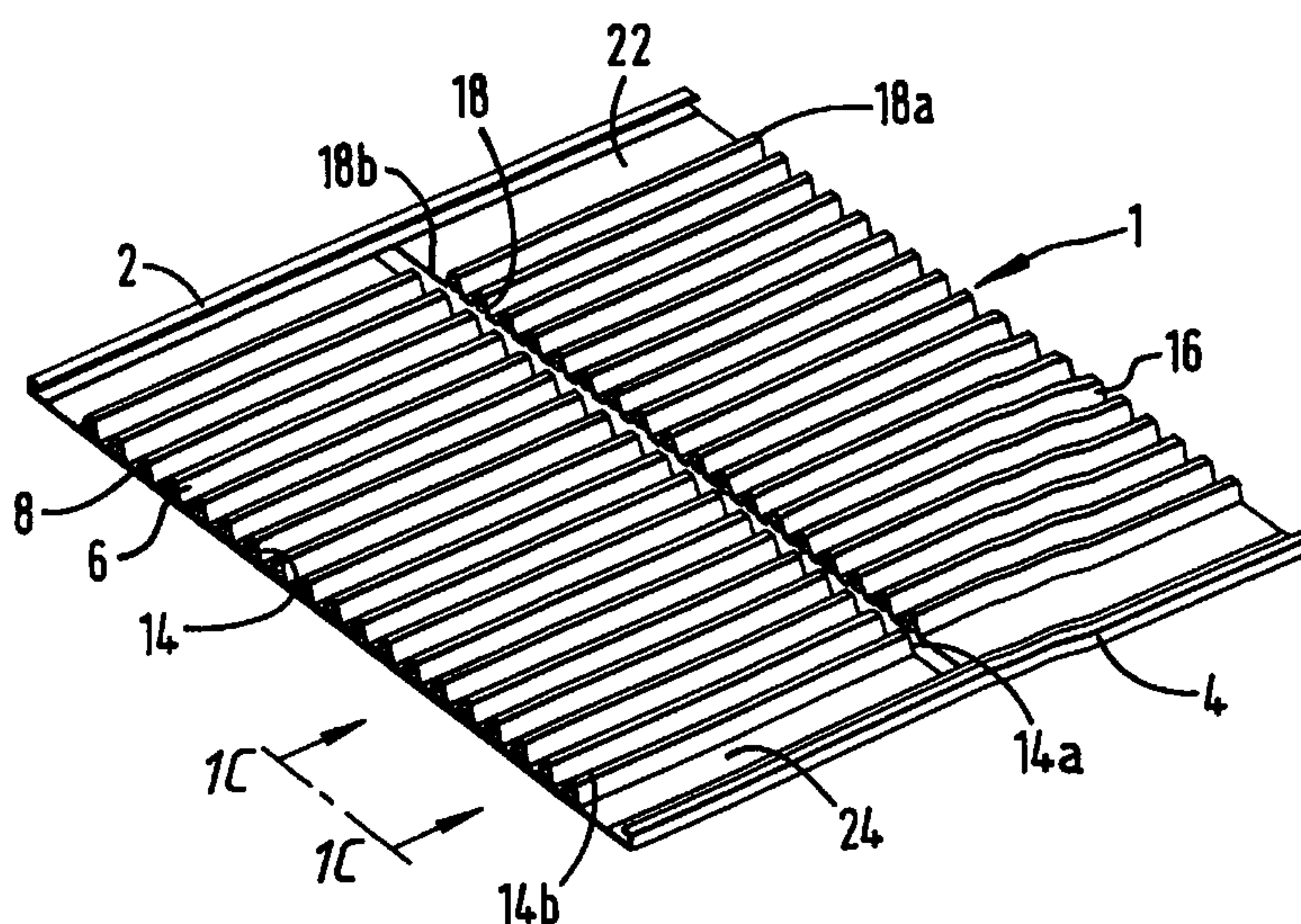
(54) Title: SCREEN ASSEMBLY, VIBRATORY SEPARATOR AND METHOD OF SCREENING**(57) Abstract**

A screen assembly for a vibratory separator, the screen assembly comprising at least two ridge-valley series of screening material (14, 16) each of which comprises a plurality of alternating ridges (18) and valleys (20) of screening material, wherein at least one of the ridge-valley series of screening material (14) is offset from at least one other ridge-valley series of screening material (16). A screen comprising screening material (43) formed with ridges characterised in that said ridges are of at least two different sizes. A screen comprising screening material having a plurality of ridges and at least two sides, characterised in that said ridges are arranged at an acute angle to one of said sides. A screen comprising screening material having at least one elongate ridge and valley, characterised in that said ridge differs in shape therealong. Vibratory separators provided with a screen of the invention and methods of using same.

- 1 -

SCREEN ASSEMBLY, VIBRATORY SEPARATOR AND METHOD OF
SCREENING

The present invention relates to a screen assembly, a vibratory separator and a method of screening.

5 When drilling a wellbore in the earth's surface, drilling fluid is used to maintain the tip of a drill cool and to carry solids to the surface of the wellbore. Once at the surface the solids are removed from the drilling fluid which can then be re-used.

10 Types of apparatus that can remove solids from drilling fluid include a vibratory separator known as shale shaker. A typical shale shaker is disclosed in PCT Publication No. WO 96/33792. Typically, it is known to provide such equipment with one or more screens of wire
15 mesh for filtering the drilling fluid. Typically, the wire mesh is very fine and does not have a high durability. It is advantageous to have a screen which has high durability.

20 Shale shakers are limited in size, especially those used on offshore platforms where space is at a premium. Accordingly, it is advantageous to filter a large quantity of particle laden mud using standard size shale shakers.

25 It is also advantageous for screens to be easily replaceable and repairable.

 It is also advantageous to increase the residence period of the particle laden fluid on the screen.

30 According to a first aspect of the invention, there is provided a screen assembly for a vibratory separator, the screen assembly comprising at least a first and
35 second ridge-valley series of screening material comprising a plurality of alternating ridges and valleys of screening material, each ridge having a ridge end, characterised in that at least one of said ridge ends of said first ridge-valley series of screening material is

- 2 -

offset from at least one ridge end of said second ridge-valley series of screening material.

5 Other preferable or advantageous features of the first aspect of the invention are set out in Claims 2 to 15.

There is also provided a method for screening using the screen assembly of the first aspect of the invention.

10 The first aspect of the present invention also provides a vibratory separator comprising at least two ridge-valley series of screening material comprised of a plurality of alternating ridges and valleys of screening material, and at least one of the ridge-valley series of screening material offset from at least one other ridge-valley series of screening material.

15 The first aspect of the invention further provides a method for screening using the vibratory separator of the invention, the method comprising the step of vibrating said at least two ridge-valley series of screening material, pouring a particle laden fluid on to one of
20 said at least two ridge-valley series of screening material thereon, allowing fluid and predetermined size particles therethrough, and vibrating particles larger than said predetermined size to a far end of one other of said at least two ridge-valley series of screening
25 material.

* * *

According to a second aspect of the present invention, there is provided a screen comprising screening material formed with ridges characterised in
30 that said ridges are of at least two different heights.

Other preferable or advantageous features of the second aspect of the invention are set out in Claims 20 to 26.

35 There is also provided vibratory shaker comprising a screen of the second aspect of the invention. Preferably,

- 3 -

the vibratory shaker comprises a second screen, wherein said ridges are in line with ridges of said first screen. If desired, the vibratory shaker may comprise a further screen with ridges which are optionally offset from said ridges of said first screen.

* * *

According to a third aspect of the present invention there is provided a screen for a shale shaker, said screen comprising screening material having a plurality of ridges and at least two sides a forward end and a trailing end, characterised in that said ridges run from said forward end to said trailing end at an acute angle to one of said sides.

Other features of the third aspect of the invention are set out in claims 31 to 39.

There is also provided a screen assembly for a vibratory separator, the screen assembly comprising at least two ridge-valley series of screening material including at least a first series adjacent a second series, said first series comprising a first side series and a second side series each of a plurality of ridges and valleys, said first side series at an angle to said second side series as viewed from above, and said second series comprising a third side series and a fourth side series each of a plurality of ridges and valleys, said third side series at an angle to said fourth side series as viewed from above.

The third aspect of the present invention also provides a vibratory separator comprising a screen as of the third aspect of the invention.

* * *

A fourth aspect of the invention provides a screen comprising screening material having at least one elongate ridge and valley, characterised in that said ridge differs in shape therealong.

- 4 -

Other preferable or advantageous features of the fourth aspect of the invention are set out in Claims 45 to 49.

5 There is also provided a screen assembly for a vibratory separator, the screen assembly comprising at least one ridge-valley series of screening material, said ridge-valley series including a plurality of ridges each ridge between valleys of a plurality of valleys, and each ridge having a first end and a second end, said first end
10 having a top wider than a top of the second end.

Other preferable or advantageous features of the fourth aspect of the invention are set out in Claims 52 to 54.

15 The fourth aspect of the present invention also provides a vibratory shaker comprising a screen of the fourth aspect of the invention.

* * *

20 A fifth aspect of the present invention provides a screen assembly for a vibratory separator, the screen assembly comprising a ridge-valley series of screening material having a plurality of alternating ridges and valleys and two spaced apart ends having ridge openings below the ridges, said openings covered with screen or mesh material characterised in that said openings are
25 covered with screen or mesh material in a generally bulbous shape.

Other preferable or advantageous features of the fifth aspect of the invention are set out in Claims 56 to 66.

30 The fifth aspect of the present invention also provides a vibratory shaker comprising a screen of the fifth aspect of the invention and a method for screening using the vibratory separator.

35

- 5 -

For a better understanding of the present invention, reference will now be made, by way of example, to the accompanying drawings, in which:

5 Figure 1A is a perspective view of a screen apparatus according to a first aspect of the present invention;

Figure 1B is an enlarged view of part of the screen apparatus of Figure 1A;

10 Figure 1C is a end view taken from line 1C-1C of Figure 1A;

Figure 1D is a end view of a second embodiment of a second screen, similar to the screen of Figure 1A;

Figure 1E is a perspective view of a third screen;

* * *

15 Figure 2A is a perspective view of a screen apparatus according to a second aspect of the present invention; Figure 2B is an enlarged view of part of the screen apparatus of Figure 2A; Figure 2C is a view along line 2C-2C of Figure 2A;

20 Figures 2D - 2H show a selection of end shapes for ridge end covering according to the present invention;

Figure 3A is a top view of a screen apparatus according to a third aspect of the present invention; Figure 3B is an end view of the screen apparatus of
25 Figure 3A;

Figure 4 is a top view of a screen according to fourth aspect of the present invention;

30 Figure 5 is a perspective view of a screen according to the first, second and a fifth aspect of the present invention;

Figure 6A is a top view of a screen according to the first and third aspect of the present invention; Figure 6B is an end view of the screen of Figure 6A;

35 Figure 7A is a perspective view of a screen part according to a sixth aspect of the present invention;

- 6 -

Figure 7B is a perspective view of a screen with parts as in Figure 7A;

Figure 1A - 1C show a screen assembly generally identified by reference numeral 1 for use in, for example, a vibratory shaker such as a shale shaker. The screen assembly 1 has hook strips 2 and 4 on either side thereof. Screening material 6 is connected along the length of each hook strip by known methods, for example folding, welding, crimping together, epoxying, press/fiction fit, and/or interlocking of parts. In one aspect no underlying plate, straps, or strips and no frame are used with the screen assembly 1.

The screening material 6 may be any known screening material, screen and/or mesh or combination thereof and/or any screening material disclosed herein. In the screen 1 as shown, the screening material 6 includes a lower mesh (for example 1 to 80 mesh) 8 which may be a relatively coarse mesh and an upper mesh 10 (for example 8 to 400 mesh) and which may be a relatively fine mesh. Two fine mesh screens and one coarse mesh screen may also be used. The fine mesh may be bonded to the coarse mesh, sewed to the coarse mesh, glued to it, welded to it, and/or sintered to it.

An optional perforated plate or a series of straps or strips such as those disclosed in WO 94/23849, may be used below the coarse mesh. One, two, three or more layers of wire mesh may be used instead of or with such a plate, straps, or strips. In one particular aspect a flat coarse mesh (for example mesh 1 to mesh 12) is used instead of or in addition to a plate, straps, or strips.

Mesh (fine, coarse, or both) is folded over open exposed ends of ridges 14 and 18. This mesh can be substantially flat over the open ridge end or, as shown, it can protrude as part of a bulb or closed curve shape 15. Such shape can provide more screen area for

- 7 -

separation and can deflect and re-route solids and fluid to a subsequent set of valleys. Alternatively any or all openings may be plugged with a solid, porous, or perforated plug glued or welded in place. Alternatively, instead of folding screening material and/or mesh over the ends of ridges, a separate piece of screen, screens, mesh, and/or meshes can be placed at an open ridge end and the edges of the piece attached to, connected to, interlocked with, interwoven with, and/or adhered to the edges of the ridge end opening. Also, it is within the scope of this invention for any ridge end to be closed off to fluid flow, to be covered with screen(s) and/or mesh, and/or to be plugged. It is within the scope of this invention for all ridge ends on one side of a series of ridges (for example on side 18a or 14a) to be closed off to flow while the other side's ridge ends (for example on side 18b or 14b) are covered with material which permits flow [for example perforated plug, screen(s), mesh(es)]. These possibilities for end closure and end openings may be used with any screen assembly disclosed herein. It is also within the scope of this invention for all ridge ends of all ridge sets to be open.

A series of valleys or troughs 16 is interspersed between the series of ridges 14. A second series of ridges 18 and valleys is offset from the ridges 14/valleys 16, as shown in Figures 1A to 1D. Alternatively, as shown in Figure 1D the shape of one set of ridges RD can overlap (when viewed on end) the ridges RG of the other set of ridges. The ridges RD are also the same size as the ridges RG, as are the valleys. It is within the scope of this invention to employ any desired amount of such overlap. As shown, for example in Figures 1C and 1D, the ridges are of substantially the same height and ridge ends are of substantially the same

- 8 -

cross-sectional area. It is also within the scope of this invention for the ridges of one set of ridges to be of a different width than those of the other set; for the one set to be wider or narrower than the second set; for
5 ridges or ridge ends on one set to have a different cross-sectional area than those of another set; and/or to employ three, four, five, six or more series of offset ridges on a single screen. Optional side paths 22 and 24 may be eliminated by having a ridge edge or ridge
10 adjacent a hook strip 2, 4 side or positioned against a frame side (when an optional frame is used) or side member if hook strips are not used.

Figure 1E presents a screen apparatus 30 with four sets of offset ridges 31, 32, 33, 34 and hook strip sides
15 35, 36.

* * *

Figures 2A - 2C show a screen apparatus 40 for use in, for example a vibratory shaker such as a shale shaker. The screen apparatus 40 has a series of ridges 41
20 and valleys 42 of screening material 43 (like any of the screening material 16, Figure 1A). Ends of ridges are, optionally, covered with screen and/or mesh (or, alternatively, plugged as described above with either solid or perforated plugs) in a closed curved shape or
25 bulbous shape 44 or they may be flat. The screening material 43 extends between side hook strips 45, 46 on a flat screen 47. As shown in Figure 2C, ridges of the set of ridges 41 may have different heights; for example alternating high and low, high in the middle and lower on
30 the ends, or as shown in Figure 2C higher towards the sides and lower in the middle. Any such series of ridges with height differences, with width differences, and, therefore, with differing cross-sectional area and different amount of surface area may be used for any
35 ridge series or part thereof on any screen disclosed

- 9 -

herein. As shown in Figure 2C, the height (and also the cross-sectional area as viewed on end as in Figure 2C) of the ridges may gradually decrease from the sides of the screen assembly to the middle. Alternatively, the height (and cross-sectional area) may increase from the screen sides to the screen middle.

Figures 2D to 2H show possible shapes for ridge end coverings for the ends 44 (and for any ridge end disclosed herein). The coverings are designated CV-2D, CV-2E, CV-2F, CV-2G and CV-2H for Figures 2D to 2H, respectively.

Figure 3A shows a screen apparatus 50 for use in, for example a vibratory shaker or shale shaker. The screen apparatus has three sub-screens 51, 52, 53 in an integral unit. Alternatively, three sub-screens may be connected together, for example with an interlock fit or suitable fasteners. It is within the scope of this invention to employ two, four or more appropriately sized sub-screens in an integral unit or interconnected. Each sub-screen has a series of alternating ridges and valleys 51R, 52R, 53R and 51V, 52V, 53V, respectively. Each ridge-valleys is at an angle to hook strip sides SS of each screen, and the angle of the ridge-valley series of sub-screen 52 is different from that of the sub-screens 51 and 53. As shown in Figure 3B, ridges 53R of the sub-screen 53 are lined up with ridges 52R of the sub-screen 52, but it is within the scope of this invention for ridges of any set to be offset with respect to ridges of another set. For any screen in Figures 1A - 3A the hook strip sides may be eliminated and any known suitable edge or side structure may be employed. Any one of the sub-screens 51, 52, 53 may be eliminated and any two adjacent ridge-valley series in any screen herein may be offset as are the sub-screens in Figure 3A.

* * *

35

- 10 -

Figure 4 shows a screen 70 with mesh 72 supported on spaced-apart straps 76. The mesh 72 may be any suitable known type. In the screen 70, the mesh 72 is, in one aspect, a wire mesh that is bonded to the straps 76.

5 The straps 76 are secured to hookstrips 74, 75.

As shown, the screen 70 has three spaced-apart ramps 78, 80, 82. A dewatering area or pool 84 is defined between the two ramps 78, 80 and a dewatering area or pool 85 is defined between the two ramps 80, 82. The
10 ramps or raised portions 78, 80, 82 are offset between the sides of the screen such that, in use, flow of particle laden mud from one end 87 of the screen 70 to the other end 89, will have to pass over at least one ramp 78, 80, 82, or the screen may be provided, as shown
15 with a single flow path 90 located between one end of the ramp 82 and the side with the hookstrap 76. Such a location of the ramp 82 with respect to the strap 76 facilitates dewatering of solids in this area while inhibiting screen wear. Liquid rising to the top can
20 exit through the screen ramp. Similarly a strap 76 traverses the area 90. The screen 70 also has ramped portions 91 to 99 which, in use, are substantially in line with the flow of particle laden fluid. The ramped portions 91 to 99 may alternatively be normal (90° angle)
25 to the ramps 78, 80, 82.

The ramps 78, 80, 82 are between about three to about five inches wide and about raised about five inches from the pool areas 84, 85. Each ramp 78, 80, 82 has a ramped surface 78a, 80a, 82a, respectively at an angle,
30 preferably, between about twenty to about forty degrees from the horizontal, more preferably between about twenty-five to about thirty degrees, and in one particular aspect about twenty seven- degrees. Each ramp also has a rear face at between about eighty to about one
35 hundred twenty-five degrees to the horizontal, more

- 11 -

preferably between ninety and one hundred twenty degrees, and in one particular aspect about one hundred fifteen degrees.

Figure 5 shows a screen assembly 100 according to the present invention with side hook strips 102 and 104 and a two ridge-valley series 103, 105. Ridges 106 of the series 103 are higher than ridges 107 of the series 105. Any suitable spacing between ridges may be employed. The series 103, 105 may be made of any mesh or screen or meshes or screen combination disclosed herein. Any suitable plate, frame, straps or strips may be used with the screen assembly 100; but in one aspect no such item is used. In use, particle laden mud flows from the lower height series 105 to the higher height series 103; but it is within the scope of this invention to flow from a higher height series to a lower height series. As shown screening material 109, 110 [any screen(s) and/or mesh(es) described herein] is connected to (in any way disclosed herein) an optional flat coarse mesh 111.

Figure 6A shows a screen assembly 120 comprising hook strips 121, 122 and two series of ridge-valley screen material 123, 124 which have ridges 126, 126a and valleys 127, 127a arranged on one side angled to direct flow generally toward the centre of the screen assembly, and ridges 128, 128a and valleys 129, 129a arranged on the other side angled to direct flow generally toward the centre (and may converge with ridges 126, 126a and valleys 127, 127a at the centre). The screening material of the series 123, 124 is, optionally, connected to a flat coarse mesh 125. Although optional, any plate, frame, strips, or straps disclosed herein may be used with the assembly 120.

Figure 7B shows a screen assembly 150 comprising side hook strips 151, 152 and a series of ridge-valleys 153. Each ridge 154 of the series 153 is higher at one

- 12 -

end than the other, as illustrated in Figure 7A. Any desired height difference may be employed and in use, particle laden fluid may flow either way between the sides, from the higher ridge end 155 to the lower end 5 156, or vice versa. Also, a ridge end top 155 is narrower than a ridge end top 156. Alternatively, the end 155 may be wider than the end 156. Any ridge disclosed herein or any series of ridges disclosed herein may have a height differential from end-to-end (as shown 10 herein) and/or any ridge disclosed herein may have one ridge end of a particular ridge wider than the other end of the ridge and/or with different cross-sectional area. The series 153 is made of any screening material [screen(s) and/or mesh(es)] disclosed herein. The series 15 153 is, optionally, connected to a flat coarse screen (any disclosed herein) 157. Alternatively or in addition to the screen 1686 any plate, frame, strap or strips disclosed herein may be used. In one particular aspect the linear measurement $E1=E2$ and $A1+B1+C1+D1 =$ 20 $A2+B2+C2+D2$, although any suitable desired lengths may be employed, and one end (the end 155) is higher than the end 156. Ridge ends of the assembly 155, 156 (as may be any ridge end disclosed herein) may be covered or plugged in any way as described above.

25

CLAIMS:

1. A screen assembly for a vibratory separator, the screen assembly comprising at least a first and second ridge-valley series of screening material comprising a plurality of alternating ridges and valleys of screening material, each ridge having a ridge end, characterised in that at least one of said ridge ends of said first ridge-valley series of screening material is offset from at least one ridge end of said second ridge-valley series of screening material.
2. A screen assembly as claimed in Claim 1, further comprising a hook strip connection on spaced-apart sides of said at least first and second ridge-valley series of screening material.
3. A screen assembly as claimed in Claim 1 or 2, wherein said first ridge-valley series of screening material has ridges different in height from the ridges in said second ridge-valley series of screening material.
4. A screen assembly as claimed in Claim 1, 2 or 3, wherein said first ridge-valley series of screening material has at least one of said ridges of a different width to at least one of the ridges of said second ridge-valley series of screening material.
5. A screen assembly as claimed in any one of Claims 1 to 4, wherein said first ridge-valley series of screening material has ridges different in width from at least one of the valleys of said second series ridge-valley series of screening material.
6. A screen assembly as claimed in any one of Claims 1 to 5, wherein each said ridge end has an opening below said ridge covered with screen or mesh material.
7. A screen assembly as claimed in Claim 6, wherein each ridge end is covered with screen or mesh material in a generally bulbous shape.
8. A screen assembly as claimed in any one of Claims 1 to 7, wherein each ridge end is closed off to fluid flow.
9. A screen assembly as claimed in any one of Claims 1

to 8, wherein at least one of said first and second ridge-valley series of screening material has ridges of differing height, with said height higher at two-spaced apart sides of said screen assembly and said height lower in a middle between spaced-apart sides of said screening material.

10. A screen assembly as claimed in any one of Claims 1 to 8, wherein at least one of said first and second ridge-valley series of screening material wherein said ridges are of differing height with said height lower at two-spaced apart sides of said screen assembly and said height higher in a middle between spaced-apart sides of said screening material.

11. A screen assembly as claimed in any one of Claims 1 to 10, wherein said first ridge-valley series of screening material is at an angle to said second series as viewed from above.

12. A screen assembly as claimed in Claim 11 further comprising a third ridge-valley series of screening material and said second ridge-valley series at an angle to said third series as viewed from above.

13. A screen assembly as claimed in any one of Claims 1 to 12, further comprising a flat screen of screening material, said at least first and second ridge-valley series on said flat screen.

14. A screen assembly as claimed in Claim 13 wherein said flat screen is made of coarse mesh and said at least first and second ridge-valley series are made of fine mesh.

15. A screen assembly as claimed in any one of Claims 1 to 14, wherein one of said first and second ridge-valley series has larger ridges than the ridges of an adjacent ridge-valley series.

16. A vibratory separator comprising a screen assembly as claimed in any one of Claims 1 to 15.

17. A method for screening using the vibratory separator as claimed in Claim 16, said method comprising the step of vibrating said at least two ridge-valley series of screening material, pouring a particle laden fluid on to

one of said at least two ridge-valley series of screening material thereon, allowing fluid and predetermined size particles therethrough, and vibrating particles larger than said predetermined size to a far end of one other of said at least two ridge-valley series of screening material.

18. A method for screening comprising the step of vibrating a screen assembly as claimed in any one of Claims 1 to 15.

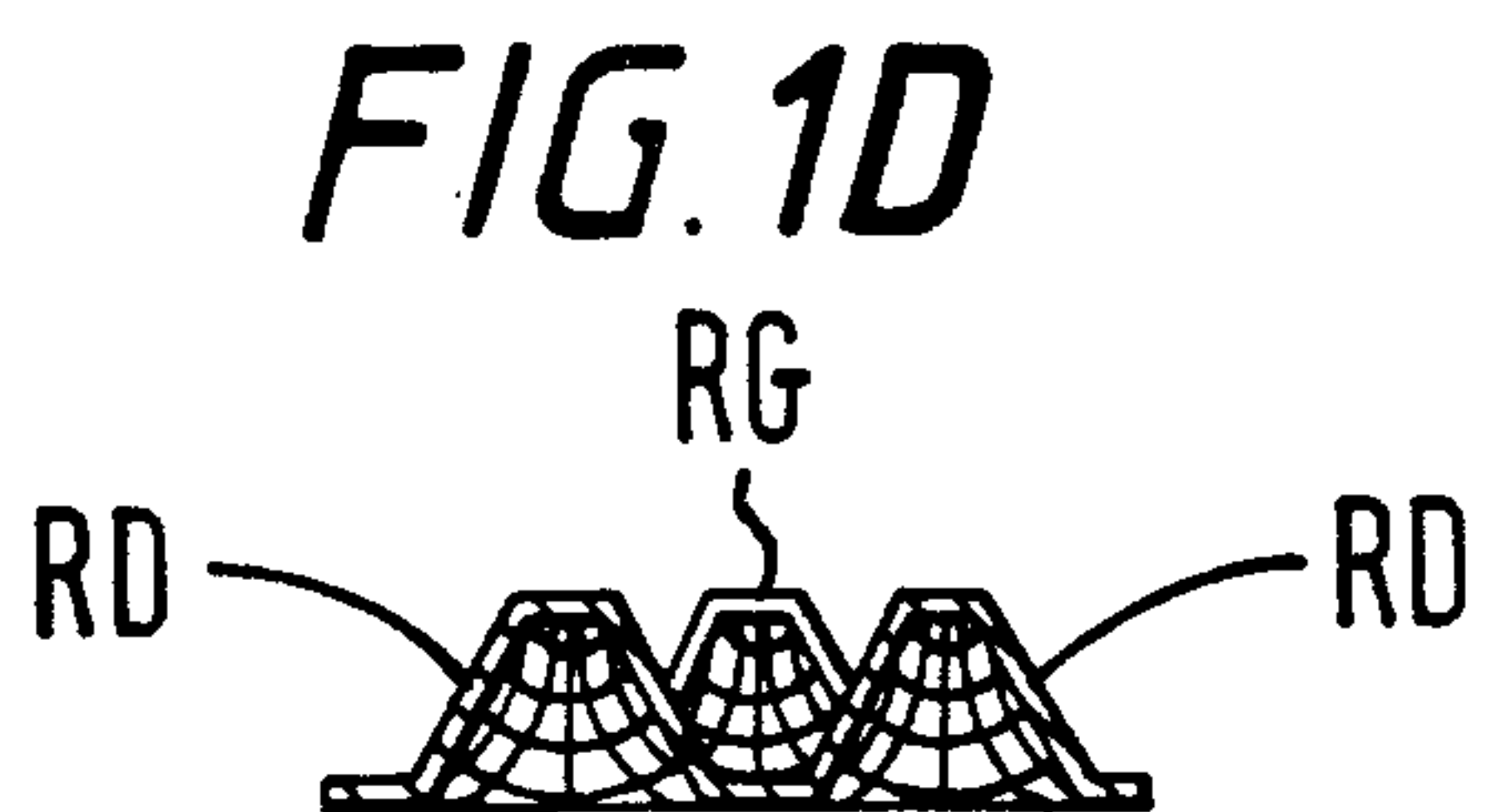
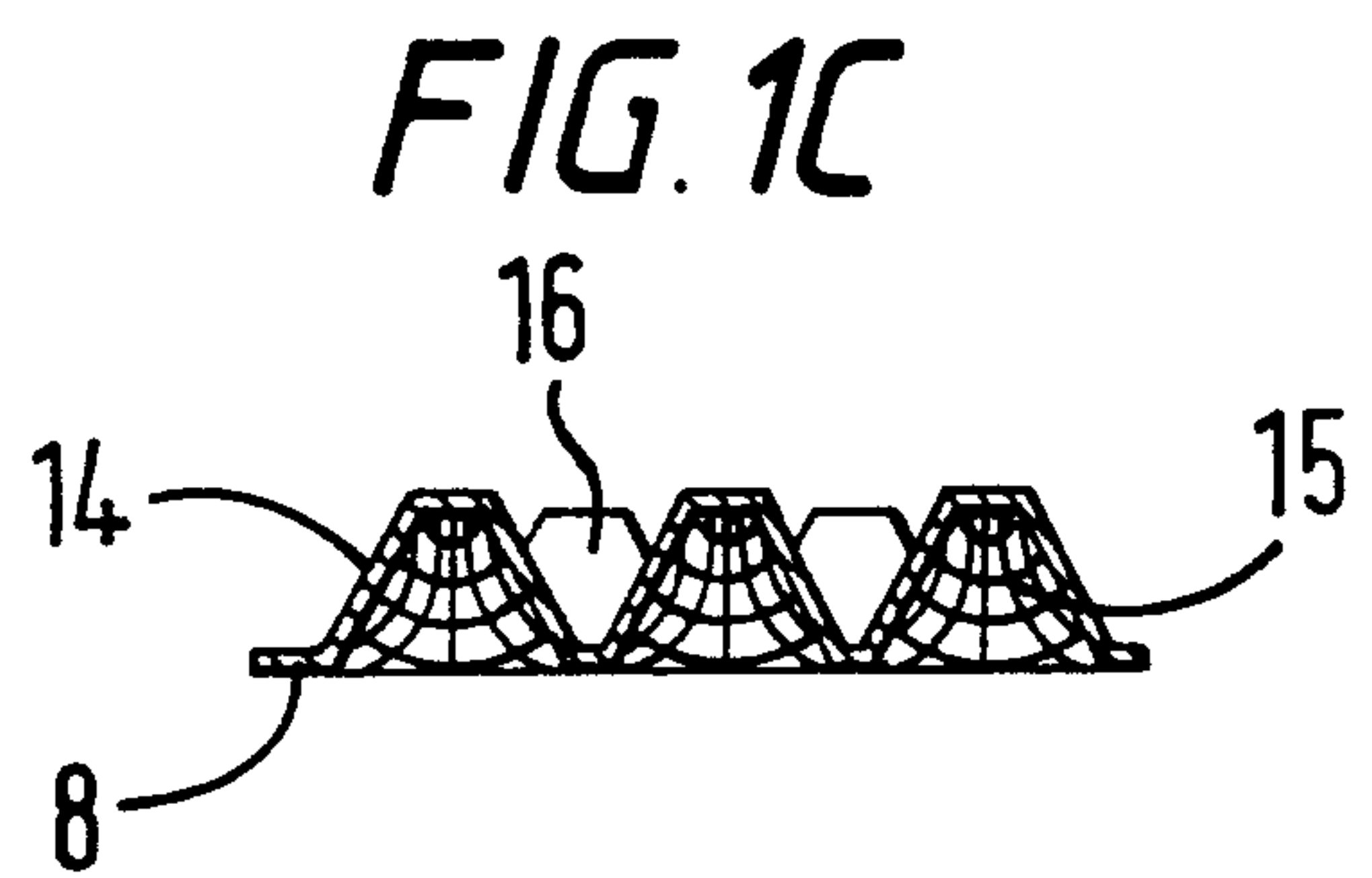
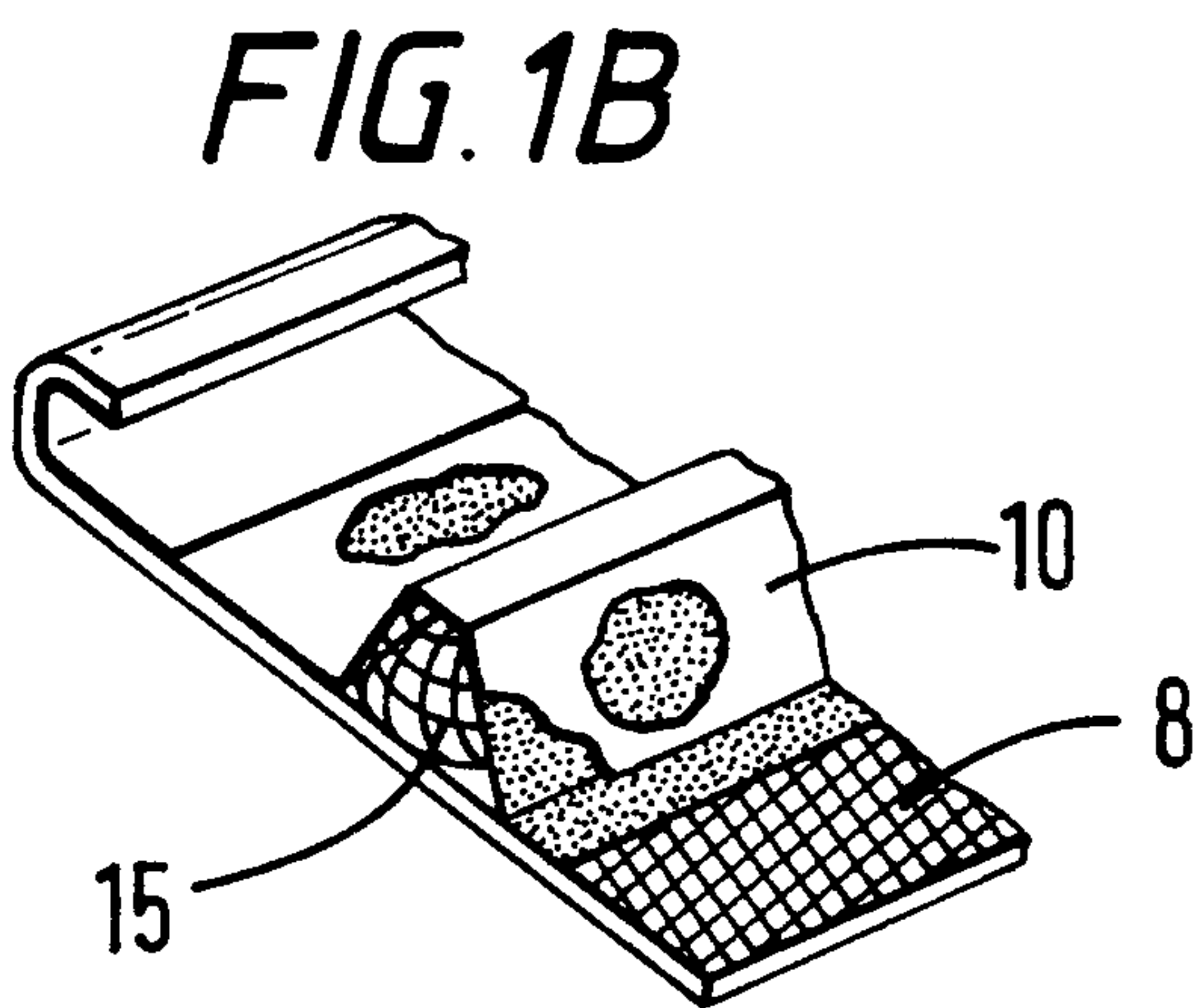
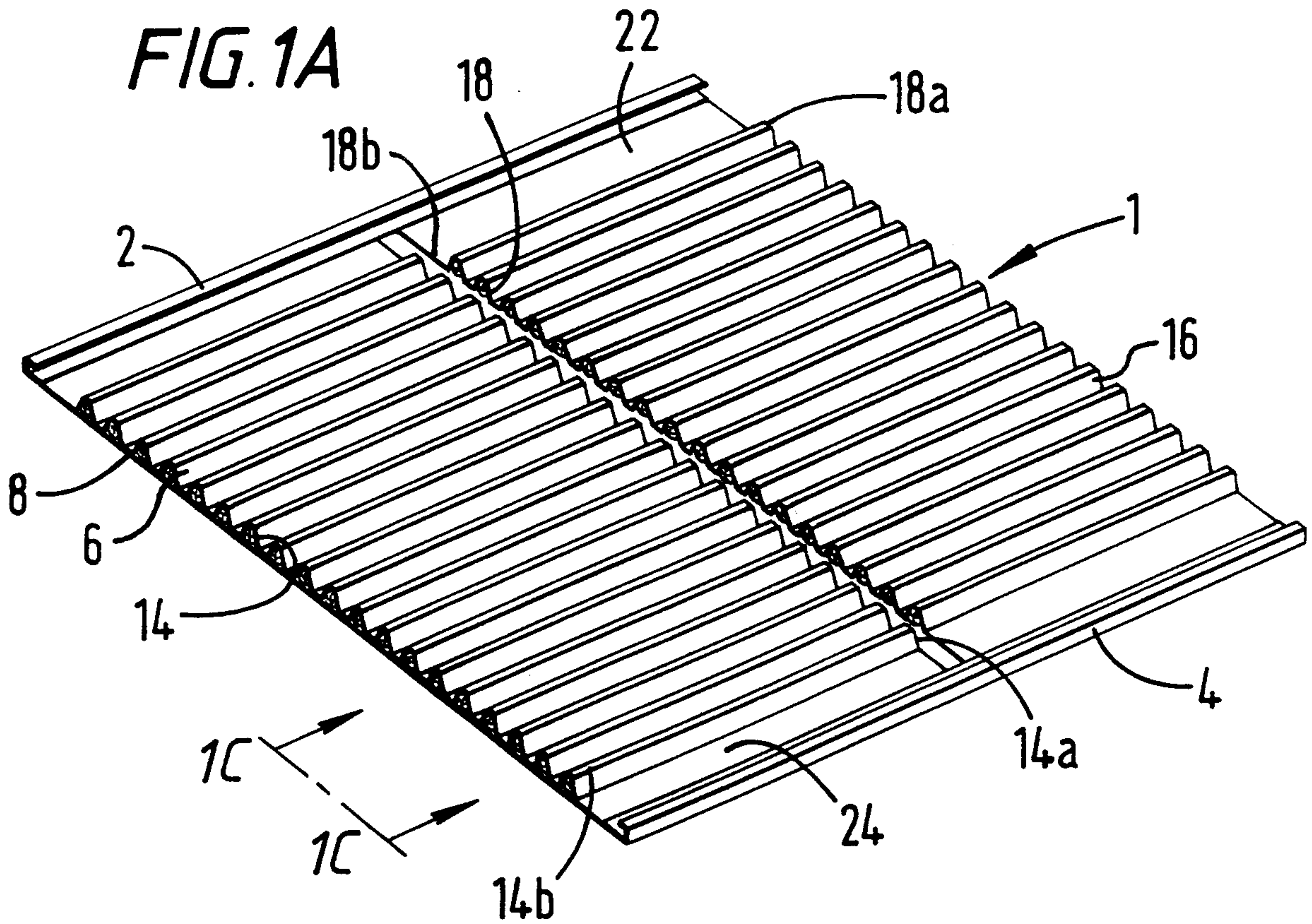

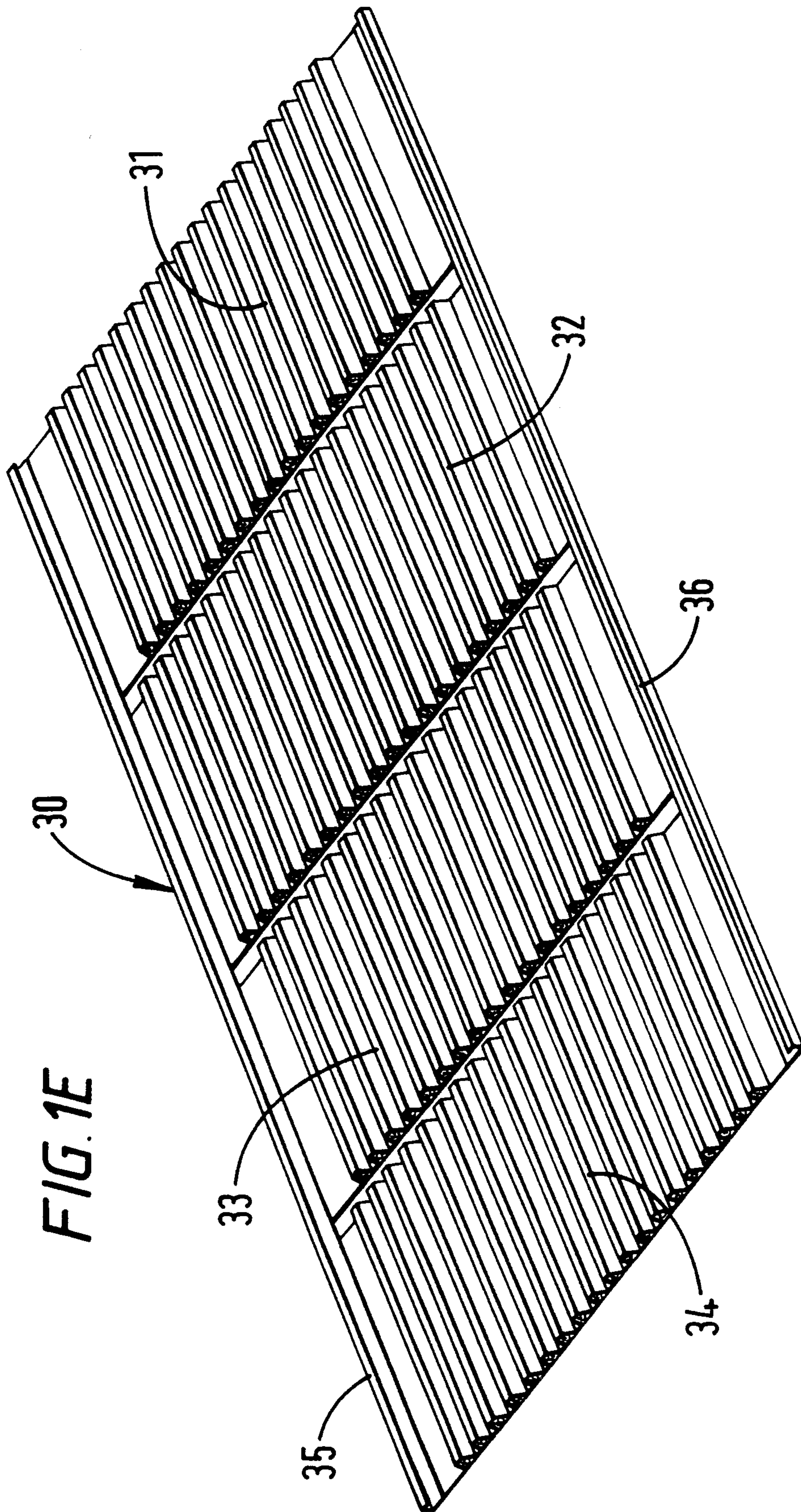

3/7

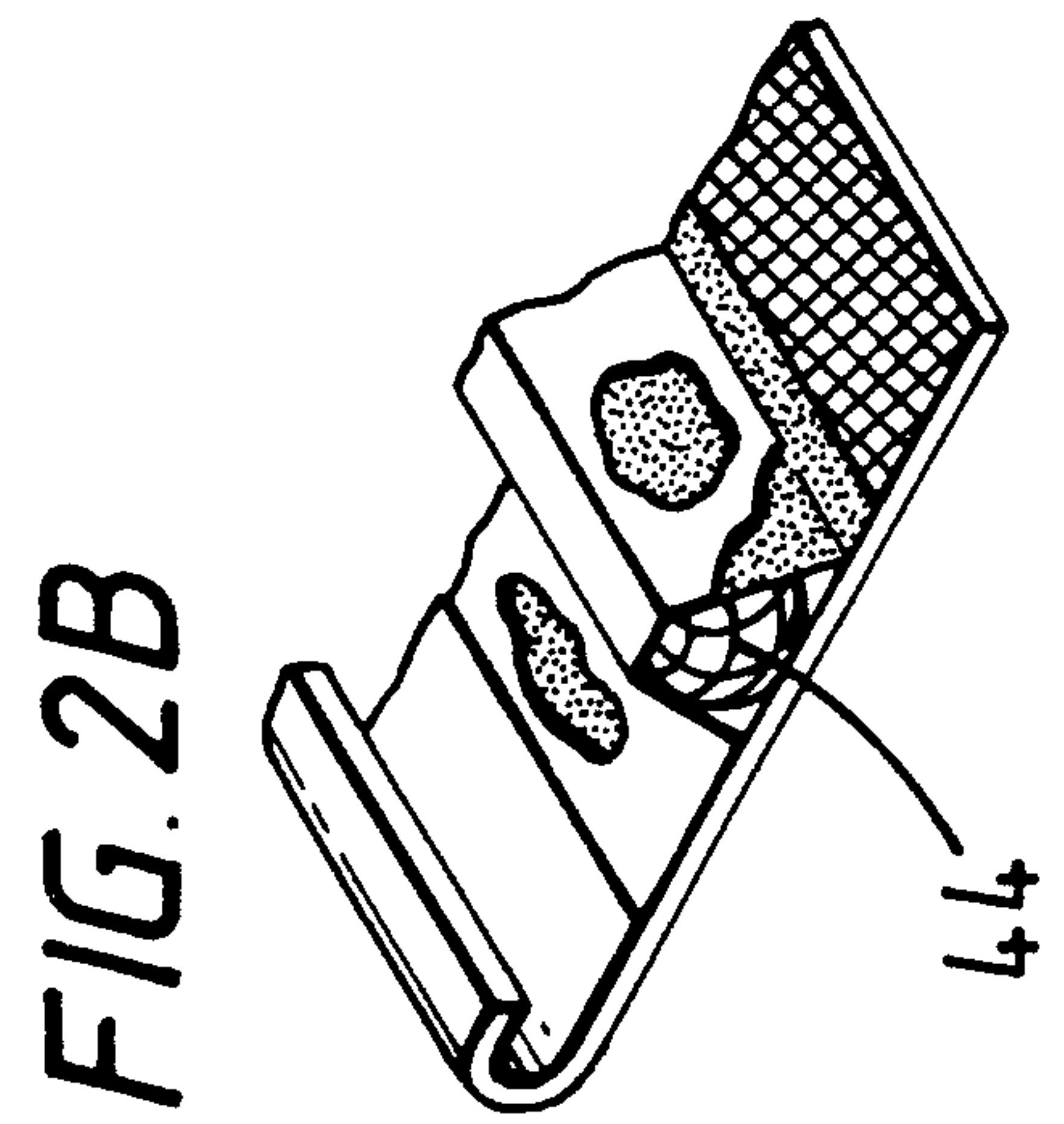
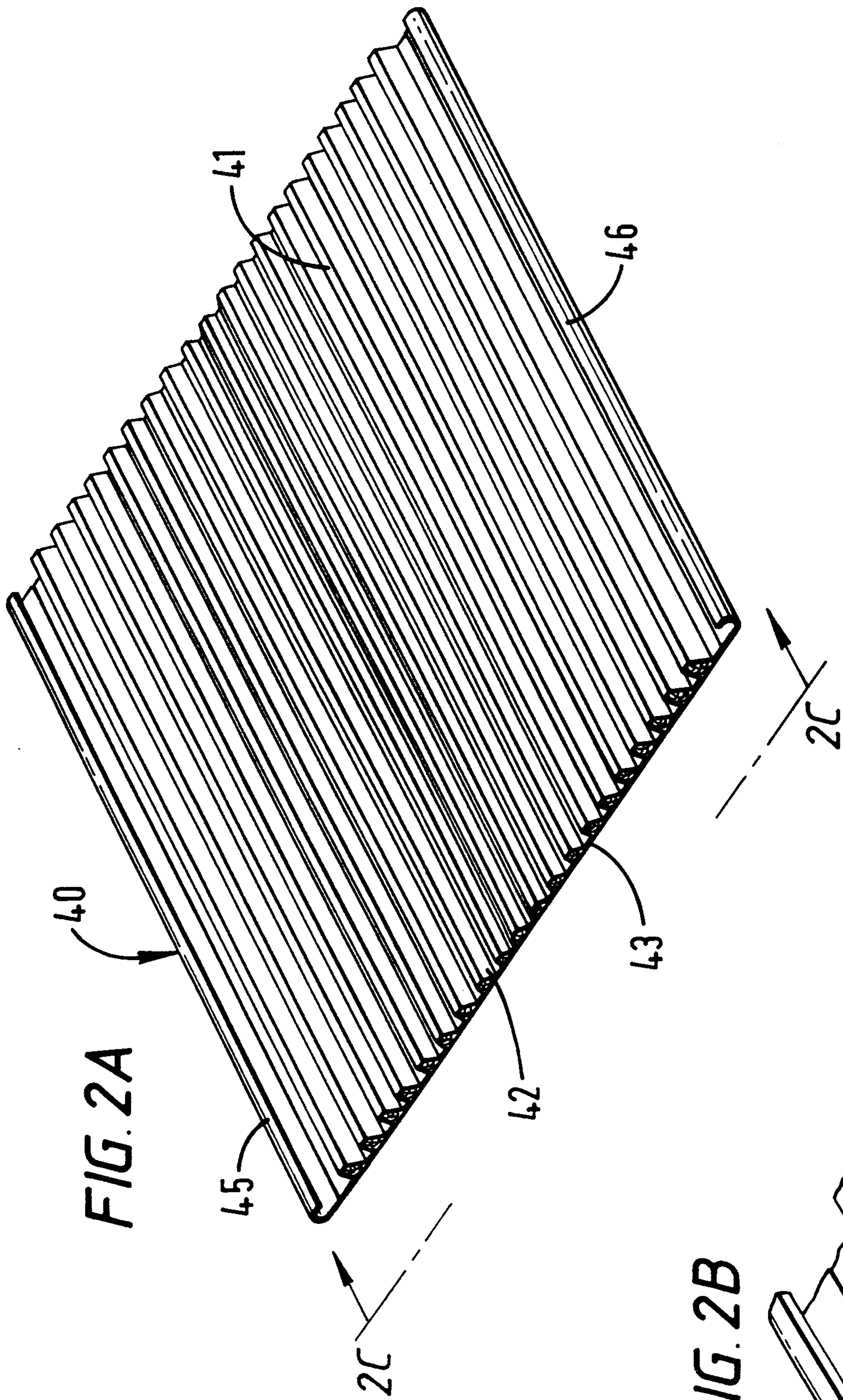

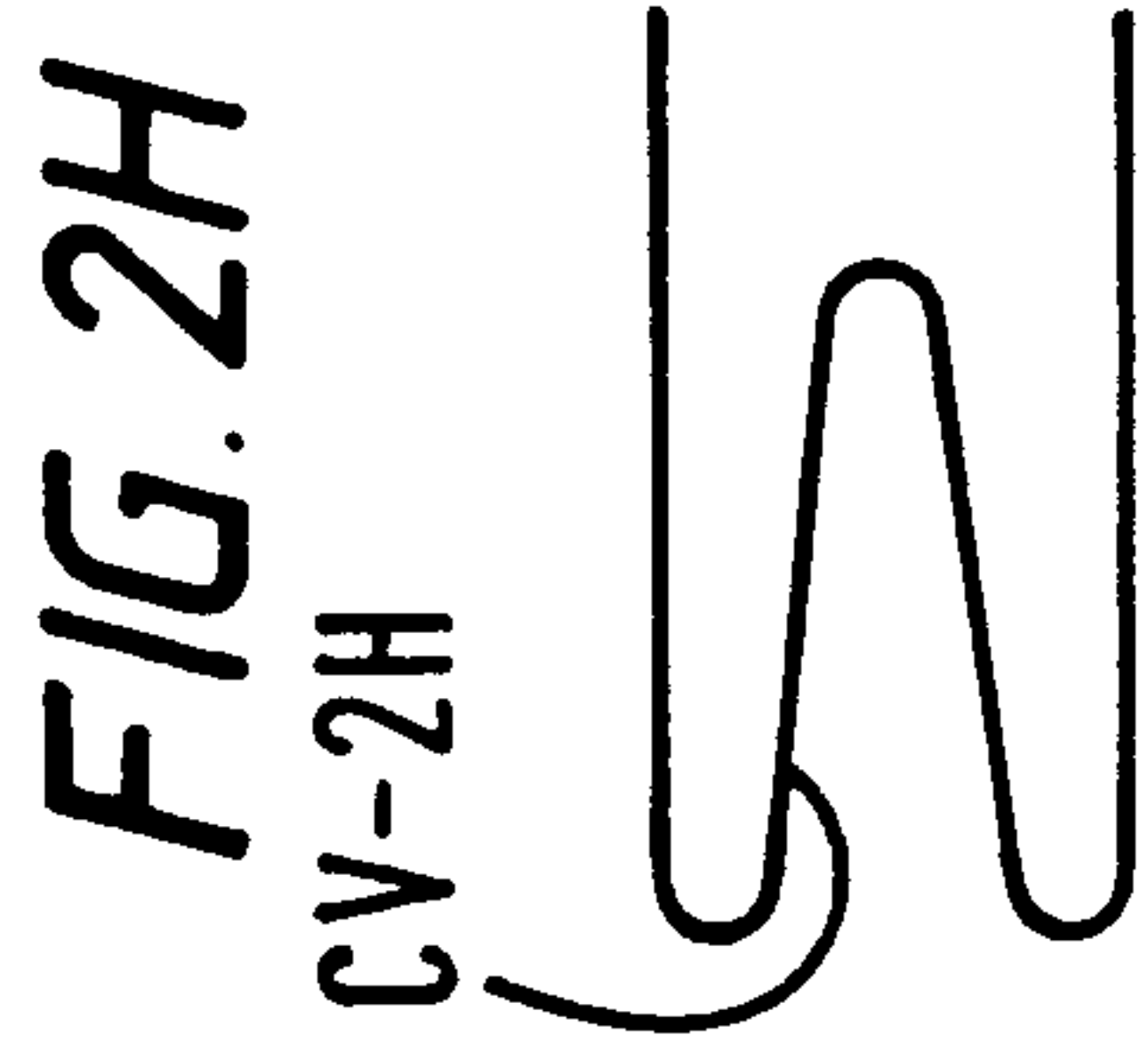
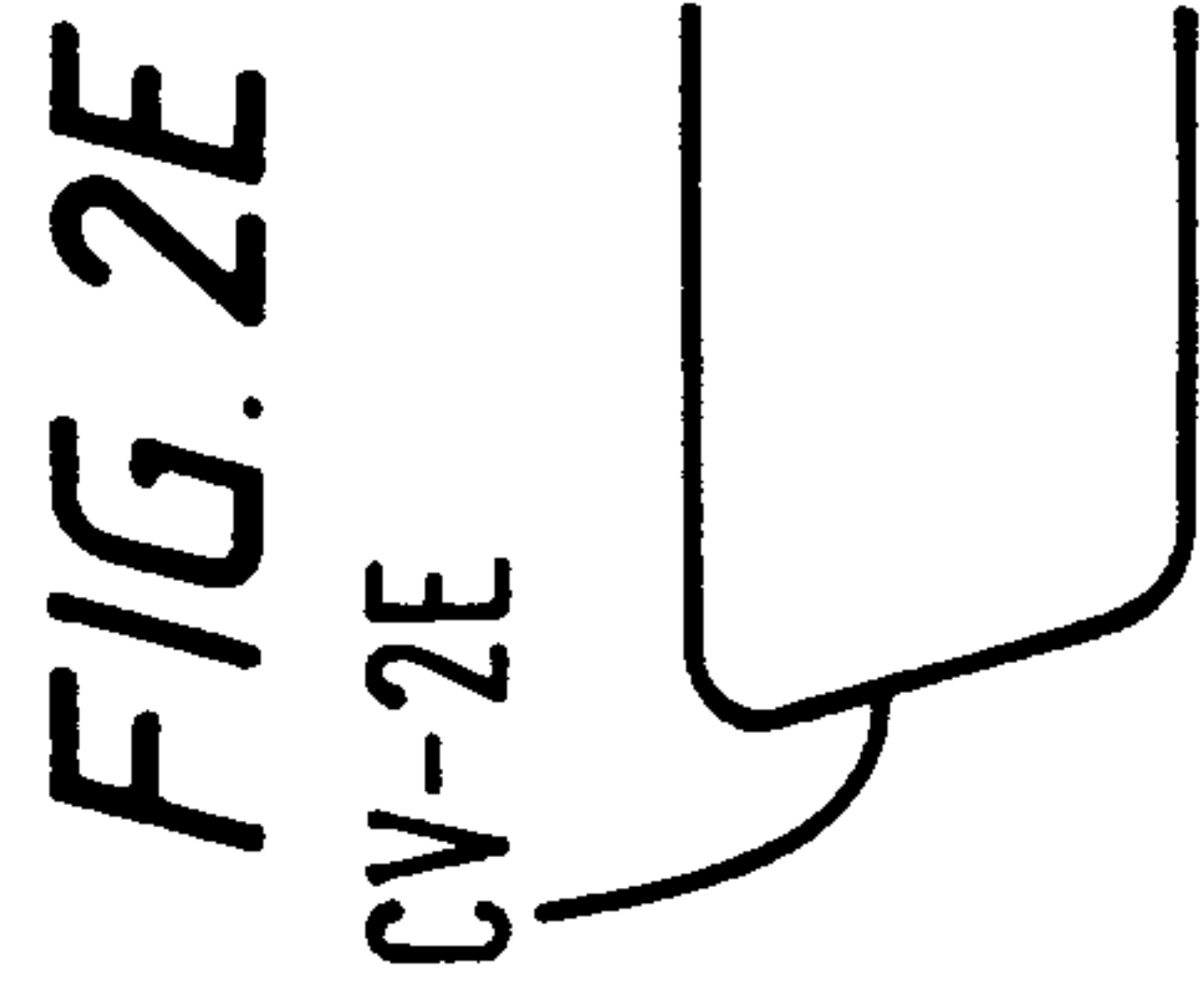
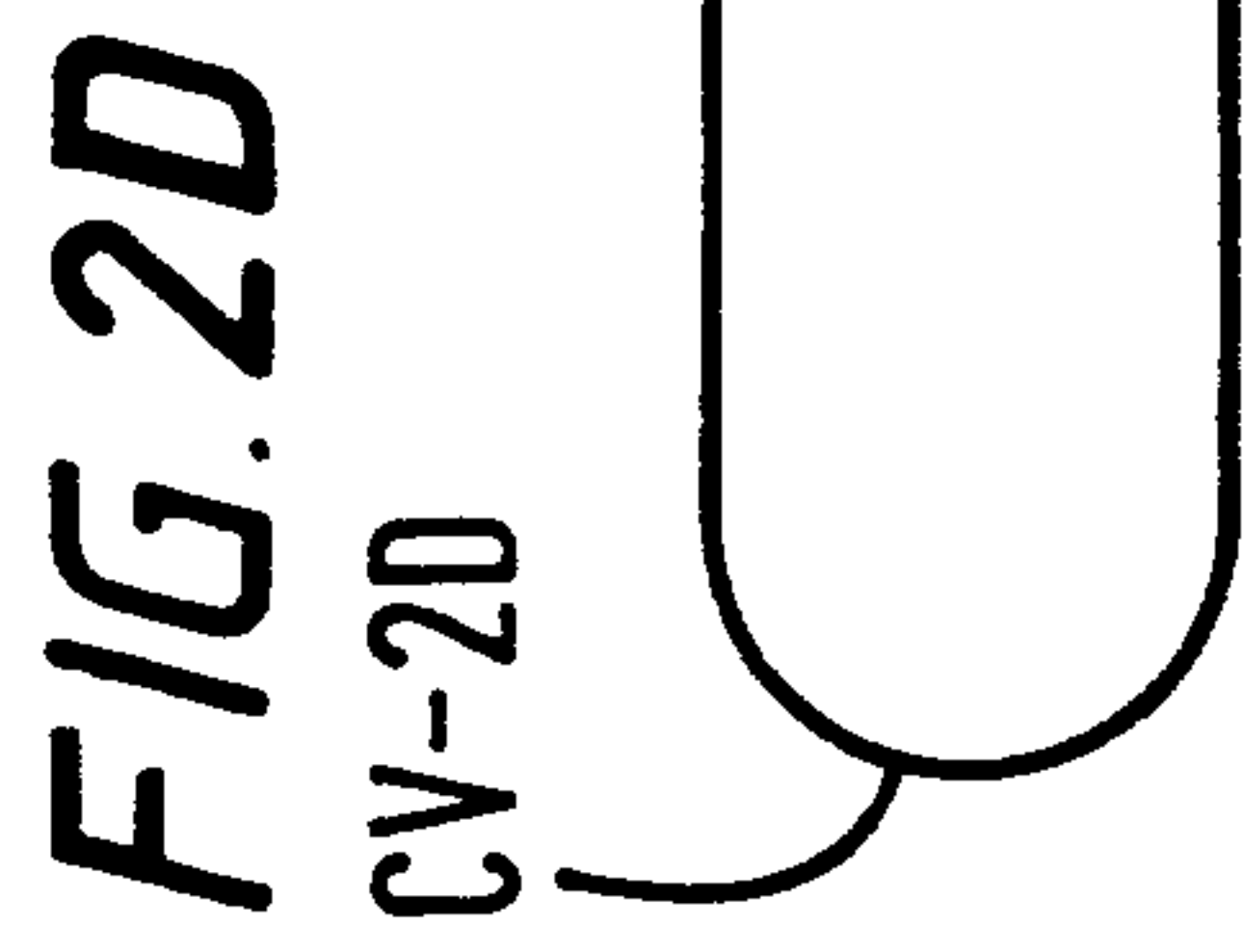
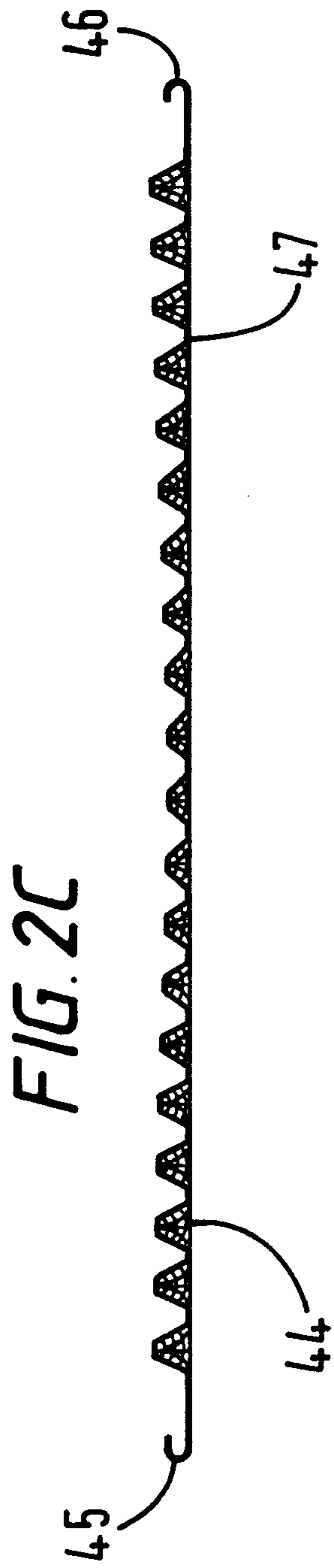

4/7

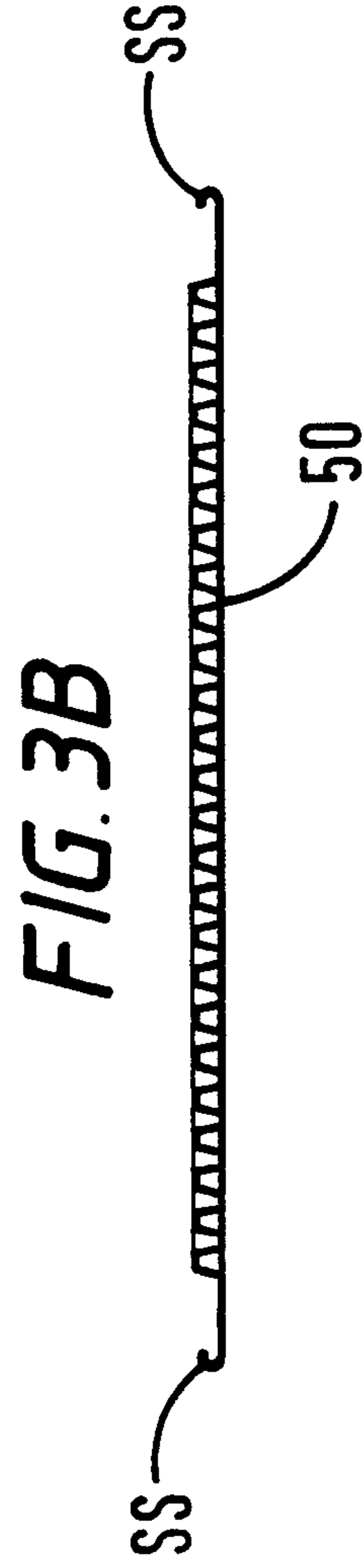

FIG. 3A

