



US00D678917S

(12) **United States Design Patent**
Hagura et al.

(10) **Patent No.:** **US D678,917 S**

(45) **Date of Patent:** **** Mar. 26, 2013**

(54) **REAR TRAY FOR CONSTRUCTION MACHINERY**

(75) Inventors: **Shigehisa Hagura**, Akishima (JP);
Hiroki Tanaka, Yuki (JP); **Tooru Harada**, Kasumigaura (JP)

(73) Assignee: **Hitachi Construction Machinery Co., Ltd.**, Tokyo (JP)

(**) Term: **14 Years**

(21) Appl. No.: **29/430,474**

(22) Filed: **Aug. 27, 2012**

(30) **Foreign Application Priority Data**

Feb. 29, 2012 (JP) 2012-004463

(51) **LOC (9) Cl.** **15-03**

(52) **U.S. Cl.** **D15/28**

(58) **Field of Classification Search** D15/22-26,
D15/28, 30, 31, 33, 10; 414/685, 686, 694,
414/722, 680, 724; 180/89.1, 89.12, 298,
180/900, 68.5

See application file for complete search history.

(56) **References Cited**

U.S. PATENT DOCUMENTS

D227,094 S *	6/1973	Skyer et al.	D15/31
D230,876 S *	3/1974	Lorenz et al.	D15/31
D352,723 S *	11/1994	DeBaal et al.	D15/31
D356,584 S *	3/1995	Innes	D15/31
D396,431 S *	7/1998	Lindgren et al.	D12/14

D406,594 S *	3/1999	Miller et al.	D15/31
D412,712 S *	8/1999	Miller et al.	D15/31
D500,056 S *	12/2004	DeYoung et al.	D15/33
D500,329 S *	12/2004	Bauve et al.	D15/28
D508,499 S *	8/2005	Kurtz, Jr.	D15/31
D517,096 S *	3/2006	Landers et al.	D15/28
D597,106 S *	7/2009	Kelley et al.	D15/31
D611,505 S *	3/2010	Loew et al.	D15/20
D611,506 S *	3/2010	Loew et al.	D15/20
D626,153 S *	10/2010	Gavin et al.	D15/31
D629,818 S *	12/2010	Rummer et al.	D15/31
D635,154 S *	3/2011	Rummer et al.	D15/28
D635,157 S *	3/2011	Rummer et al.	D15/31
D635,592 S *	4/2011	Shimomura et al.	D15/28
D636,794 S *	4/2011	Ono et al.	D15/28

* cited by examiner

Primary Examiner — Mark Goodwin

(74) *Attorney, Agent, or Firm* — Antonelli, Terry, Stout & Kraus, LLP.

(57) **CLAIM**

We claim the ornamental design for a rear tray for construction machinery, as shown and described.

DESCRIPTION

FIG. 1 is a front, top and right side perspective view of a rear tray for construction machinery showing our/my new design; FIG. 2 is a front elevational view thereof; FIG. 3 is a rear elevational view thereof; FIG. 4 is a left side elevational view thereof; FIG. 5 is a right side elevational view thereof; FIG. 6 is a top plan view thereof; and, FIG. 7 is a bottom plan view thereof.

1 Claim, 4 Drawing Sheets

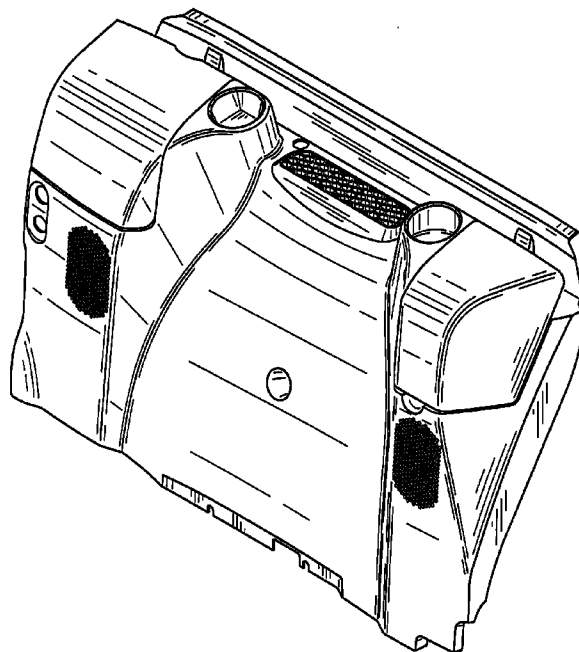

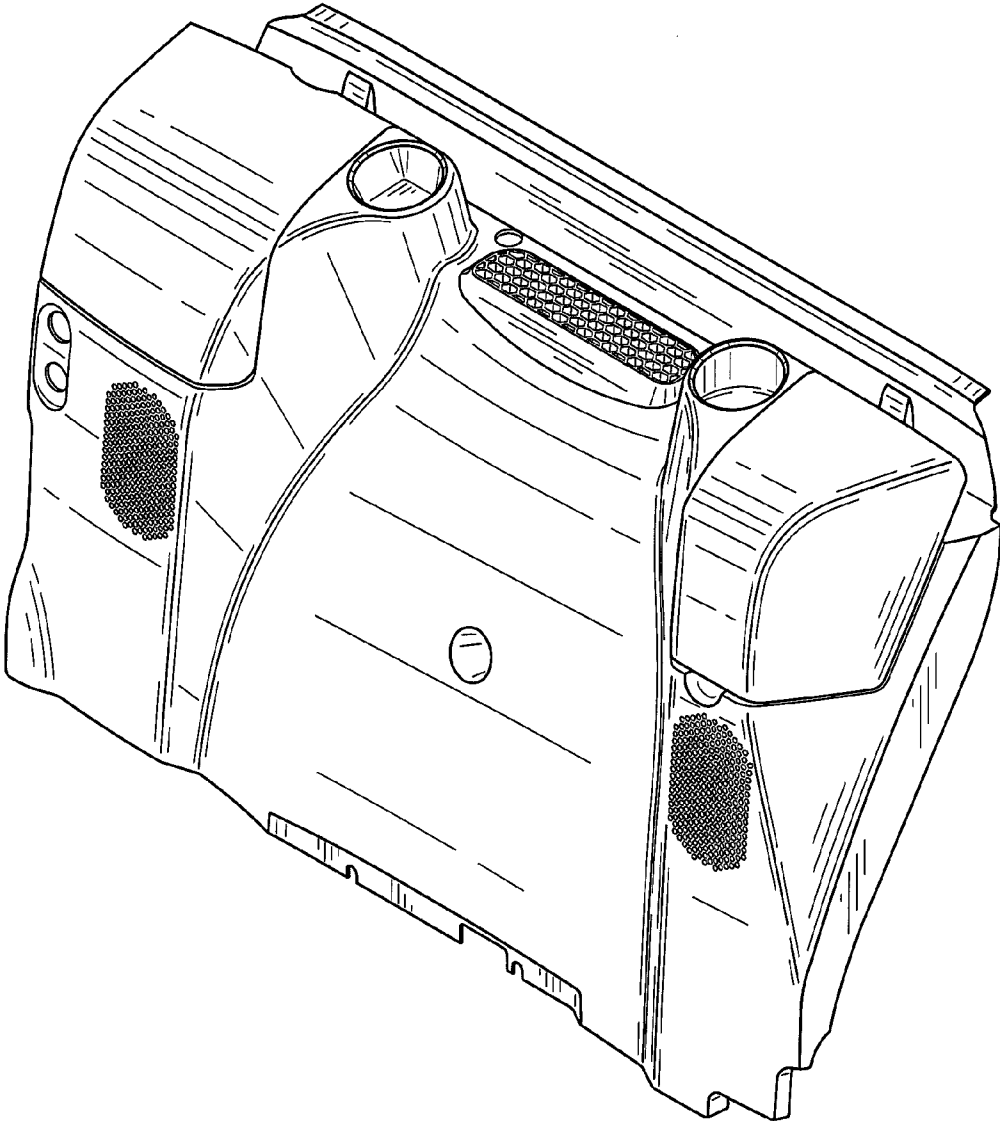

FIG. 1

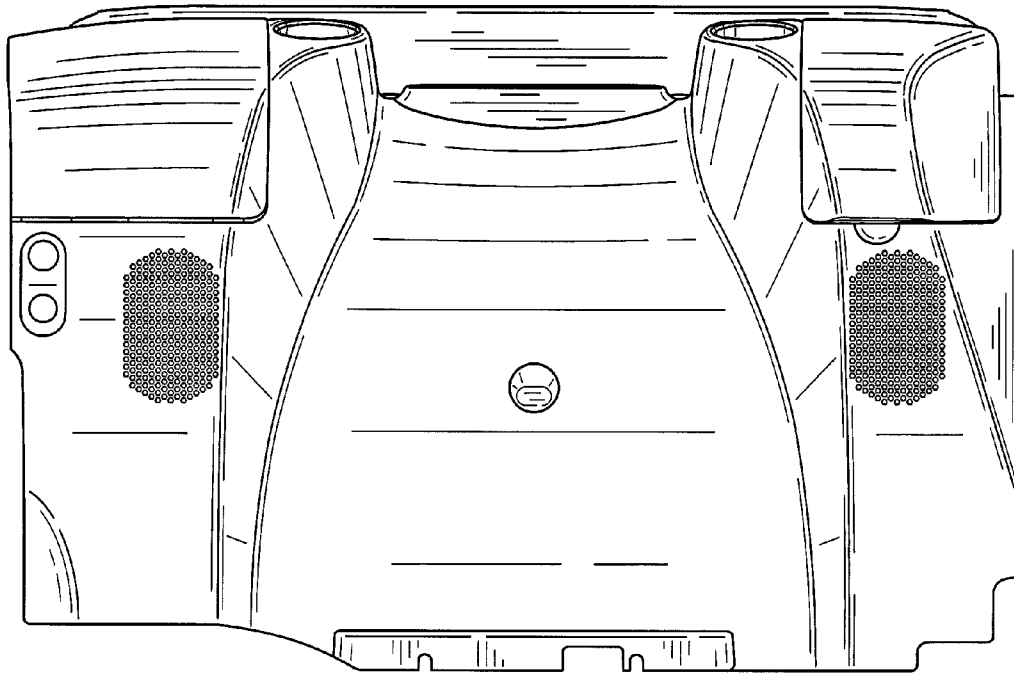

FIG. 2

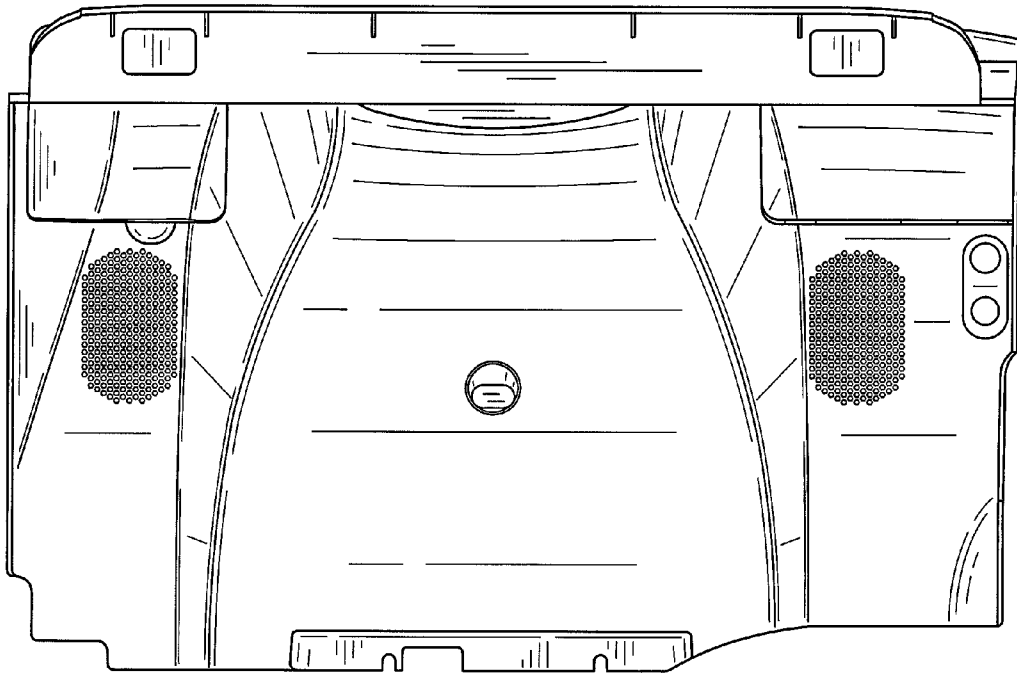

FIG. 3

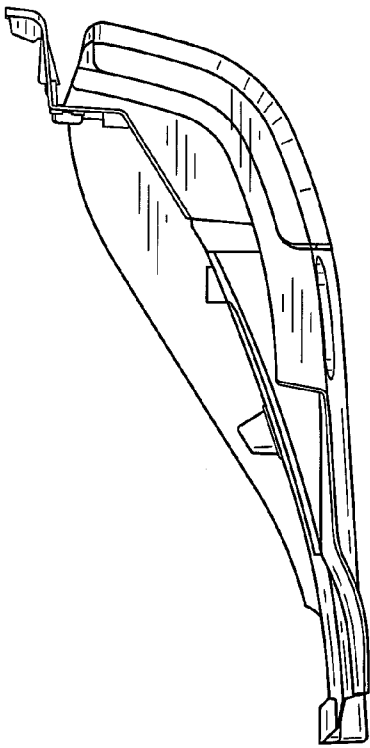

FIG. 4

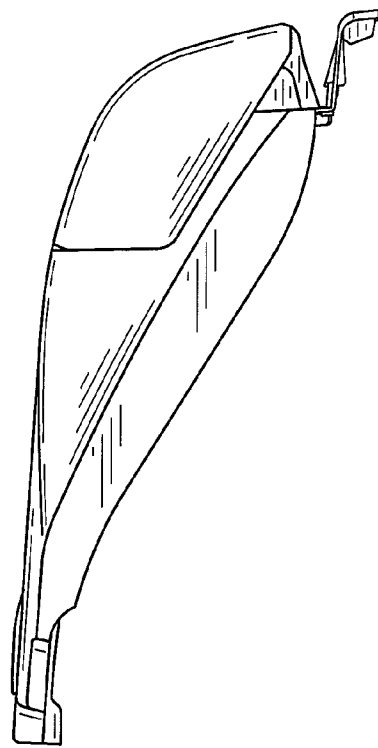

FIG. 5

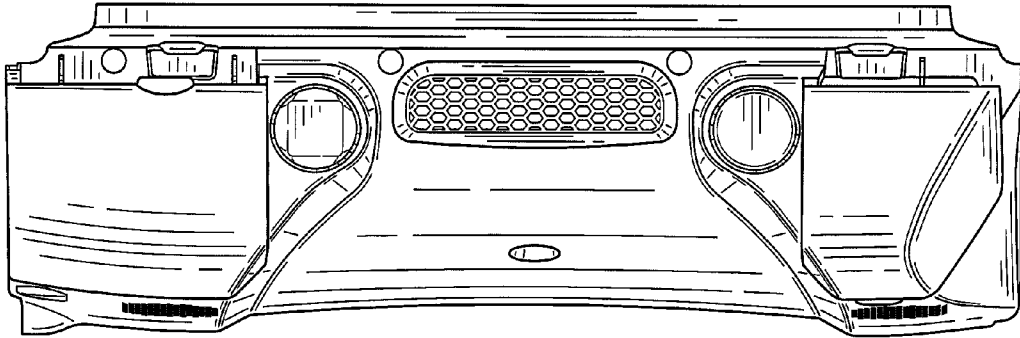

FIG. 6

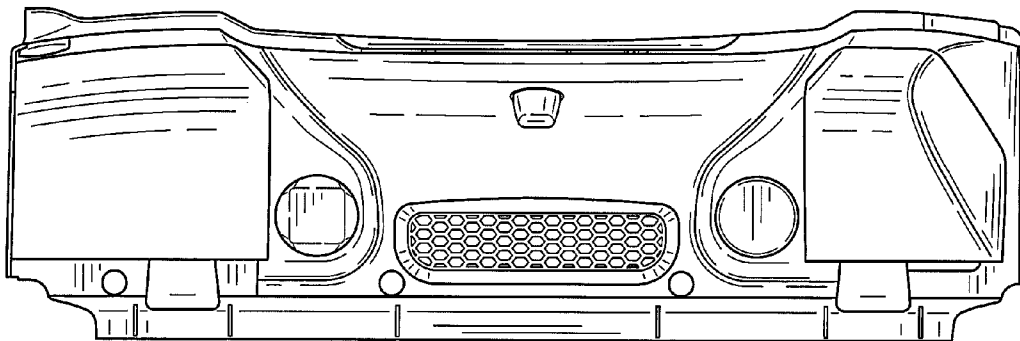

FIG. 7