

H. A. KLEMM.
KNITTING MACHINE.

(Application filed Aug. 10, 1899.)

(No Model.)

3 Sheets—Sheet 1.

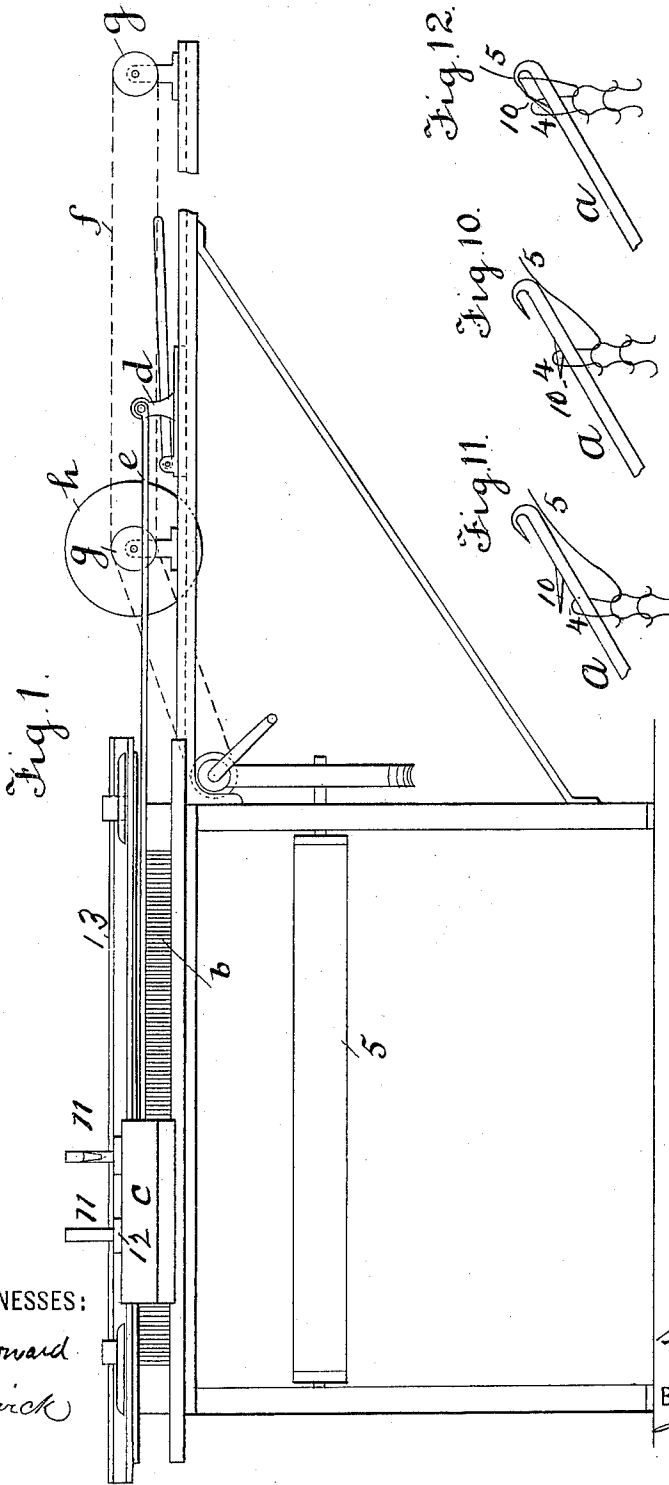

WITNESSES:
J. M. Howard
C. Sedgwick

INVENTOR
H. A. Klemm
 BY *A. O. Flayer*
 ATTORNEY

H. A. KLEMM.
KNITTING MACHINE.

(Application filed Aug. 10, 1899.)

(No Model.)

3 Sheets—Sheet 2.

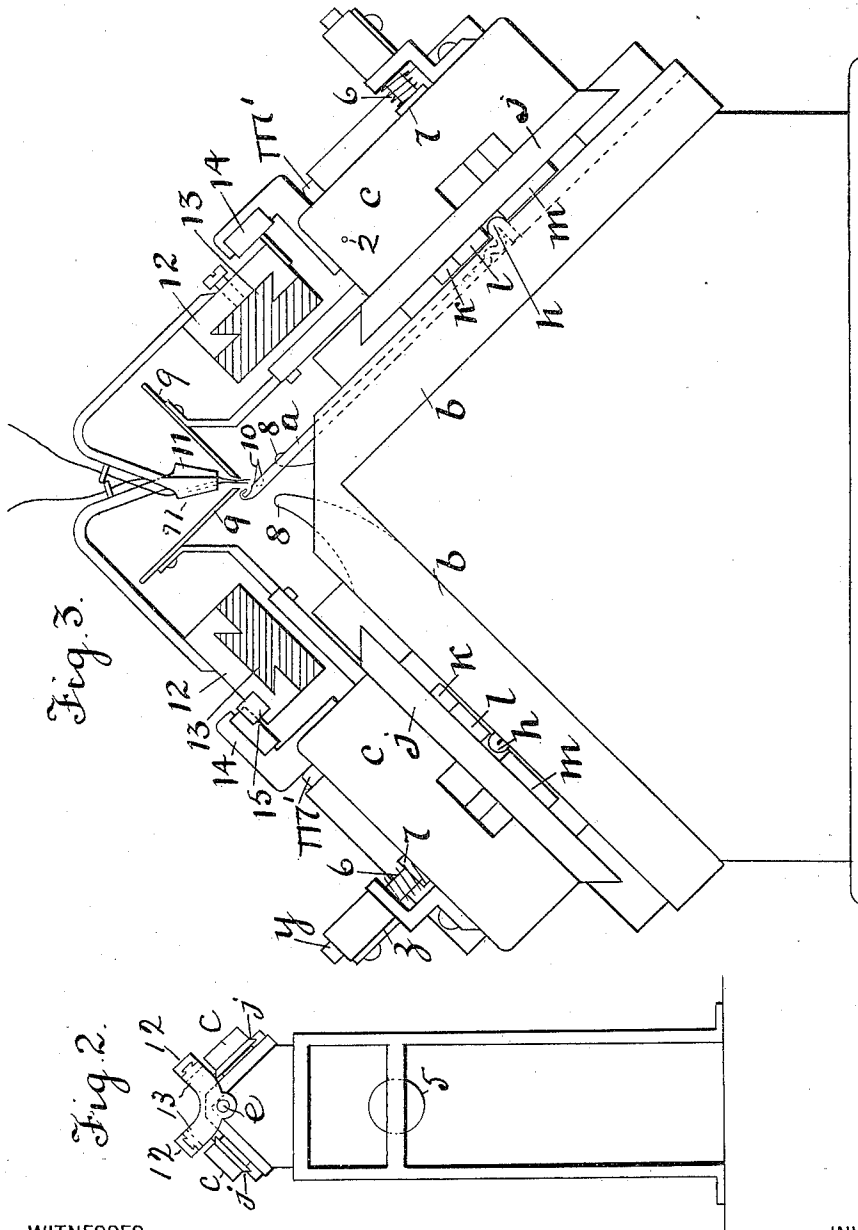

Fig. 3.

Fig. 2.

WITNESSES:

J. M. Howard.
C. Sedgwick

INVENTOR

Hermann A. Klemm

BY

A. O. Thayer
ATTORNEY

H. A. KLEMM.
KNITTING MACHINE.
(Application filed Aug. 10, 1899.)

(No Model.)

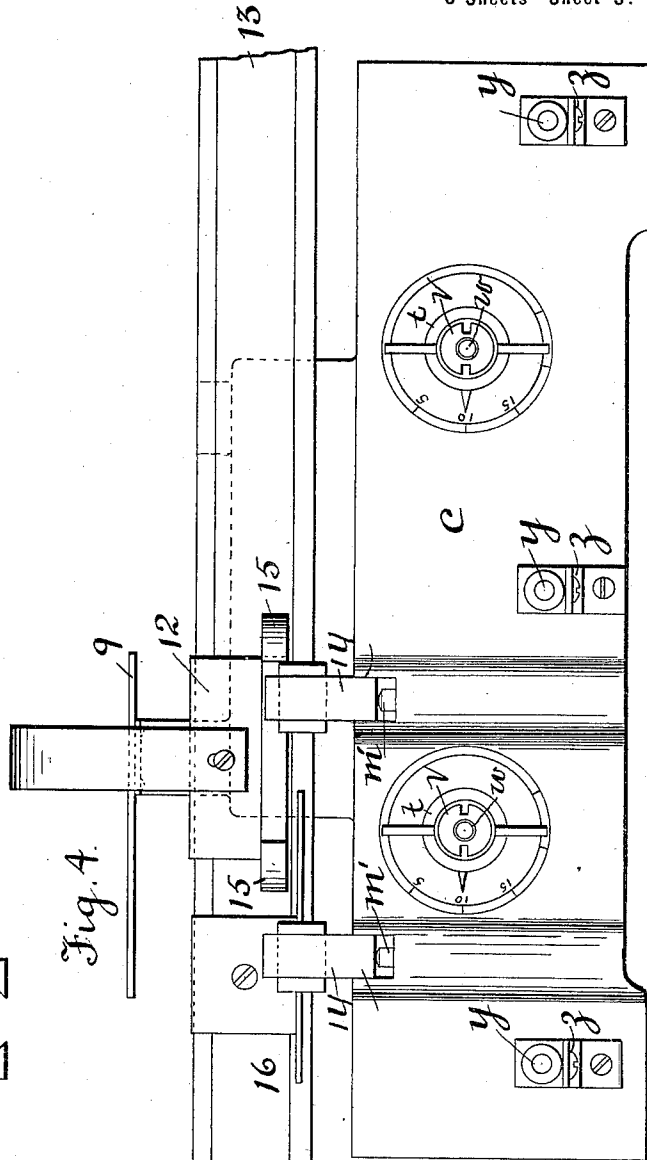
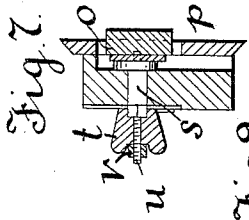
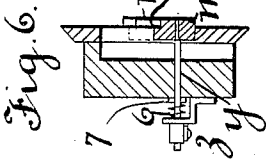
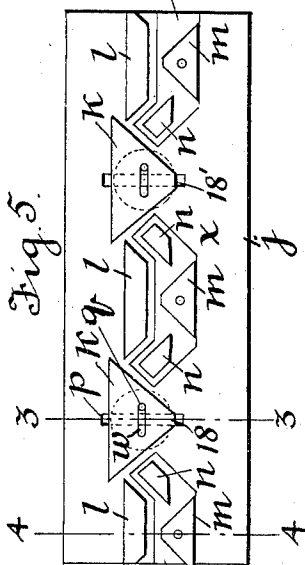

WITNESSES:
J. M. Conrad.
Cheswick

INVENTOR
Hermann Klemm
 BY
A. P. Thayer
 ATTORNEY

UNITED STATES PATENT OFFICE.

HERMANN A. KLEMM, OF NEW YORK, N. Y., ASSIGNOR, BY MESNE ASSIGNMENTS, TO JULIUS KAYSER, OF SAME PLACE.

KNITTING-MACHINE.

SPECIFICATION forming part of Letters Patent No. 652,186, dated June 19, 1900.

Application filed August 10, 1899. Serial No. 726,737. (No model.)

To all whom it may concern:

Be it known that I, HERMANN A. KLEMM, a citizen of the United States of America, and a resident of the borough of Brooklyn, New York city, State of New York, have invented certain new and useful Improvements in Knitting-Machines, of which the following is a specification.

My invention relates to improvements in straight-knitting machines; and the objects of my invention are, first, to provide an improved construction of the cam mechanism whereby the stitches may be completed with one drawing-cam in both directions and subsequent drawing and straining of the previously-made stitches is avoided, and, second, to raise the needles as the cams pass after completing the stitches part of the way, preparatory for making the next stitches, to divide the up movements of the needles into two parts, whereby they work easier with less shocks, make more uniform work, and enable the machine to run faster. These objects I attain by the mechanism illustrated in the accompanying drawings, in which—

Figure 1 is a general view of my improved machine in front elevation. Fig. 2 is an elevation as seen looking from the left hand of Fig. 1. Fig. 3 is an end view of the working parts, considerably enlarged, with the slide-ways of the traversing thread-carriers in transverse section. Fig. 4 is a plan view of one of the cam-carriages and its attachments, also part of one of the thread-carrier slide-ways and a thread-carrier, also enlarged. Fig. 5 is a face view of a cam-carriage inverted and showing the cams, the scale being about half the scale of Figs. 3 and 4. Fig. 6 is a transverse section of the cam-carriage on line 4 4 of Fig. 5. Fig. 7 is a transverse section of the cam-carriage on line 3 3 of Fig. 5. Fig. 8 is a side elevation, and Fig. 9 an end elevation, of a tripper for the thread-carrier-driving latches. Fig. 10 is a diagram showing the approximate position of a needle and the previously-made loop when the needle has been started in the upward movement preparatory to making another stitch. Fig. 11 shows the further advance in the upward movement, with the latch carried through and released from the previously-formed loop.

Fig. 12 shows the needle with the thread for the new loop in its hook and being moved downward to cast off the previously-formed loop.

The general construction of the machine is practically the same as in other knitting-machines and will only be generally described sufficiently for a proper understanding of the improvements which I claim, which will be more particularly described, the said improvements being mainly in the particular contrivances of the cams.

Two straight parallel rows of needles *a* are placed in two upper sides of the frame *b*, inclined toward each other, with a space between their upper edges, which are separated far enough for the fabric produced to pass down between them. Supported on each of the inclined sides is a carriage *c*, reciprocated by a traveler *d*, to which it is connected by a rod *e*, said traveler being suitably connected with an endless chain *f*, running over pulleys *g*, to which motion is imparted by any suitable driver, as the pulley *h*, having a driving-belt. The take-up roll for the fabric is indicated at 5. The needles are of the well-known hook-and-latch construction and have an upright shank *h* at the lower end for being operated by the cams attached underneath the carriage *c* in such a manner as to move the needles upward and downward as the carriage is moved forward and backward over the needle-beds *b*.

The plate *j*, Fig. 5, represents the under surface of one of the carriages, with the cams mounted upon it. If it be considered as belonging to the carriage *c* of Fig. 4 or of the front side of Fig. 1, it must be regarded as reversed lengthwise. If considered as belonging to the carriage of the other side of the machine, it must be regarded as turned on its lower edge, face upward. On this plate are two drawing-cams *k* and three lifting-cams, two of which lifting-cams consist of two parts *m n* and are located at the extremities of the plate, and one consists of a part *m* and two parts *n* and is located intermediately of the drawing-cams and lifts the needles to both cams—that is, there is a lifting-cam each side of a drawing-cam, and the two sides of the drawing-cam serve their turns in

drawing the needles. Each cam k has a tongue o , fitted in a groove p of plate j as a guide to the cam, which is required to be adjustable crosswise of the plate j and is coupled to a crank-pin q of a short shaft s , extending up through the top of the carriage, and has a thumb-bit t for turning it to shift the cam, with a clamping-screw u and nut v for clamping the bolt tight and holding the cam in position when set. The cam has a slot w , by which it engages the crank-pin.

The guards l are fixedly attached to the surface of the plate j , one between cams k and one at the opposite sides of the cams, respectively.

The lifting-cams m n and m n n are each attached to a holder x , that is movable backward to withdraw them out of action at times when making welts or hems, said holders being connected by rods y with cams z , which hold them out of action, and a spring 6 is provided with each rod to return the cams to and retain them in their working positions, with a collar 7 to stop the springs when the cams are in the right positions.

The comb-points 8 for casting off the stitches, knives 9 for preventing the closing of the latches 10 of the needles, and the thread-carrying guides 11 are practically the same as in other machines, also the slides 12 for carrying the thread-guides, said slides being fitted to reciprocate on the slideways 13 and being operated by the latch-drivers 14 , pivoted at 2 on the carriage c , so as to engage the catch-hooks 15 , two of which are used, one for driving in each direction, with a tripping-cam 16 to disconnect the latches from the hooks for allowing the thread-carriers to stop short of the full range of the cams, which have to overrun the range of the thread-carriers to insure the operation of all the needles to which the thread is supplied. The springs m' press the latch-drivers 14 down when escaping from tripper 16 into engagement with the hooks 15 .

It is to be understood that the cams herein represented are, as in other machines of like character, in the duplicate construction, whereby two rows of stitches are made each time the cams traverse the needle-bed, and known as "two-lock" machines.

An essential feature of the drawing-cams k is to be noted in the truncated lower extremities 18 , the purpose of which will appear farther on.

The operation of my improved cams is as follows: Supposing the machine to have been at work and having a fabric suspended from the needles, the needles will then stand about in the intermediate position—that is, after being drawn down by cam k the part m of the lifting-cam being the last to take effect on them will raise them again about half the length of their upward range, where they will be stopped by the guard l , which prevents them from being thrust upward too far when the machine runs fast, and they will be

retained in that position until the return movement of the cams by the pull of the fabric over the points of the comb and the friction due to the stress of the loops 4 of fabric on the needles between the hook and the latch, as indicated in Fig. 10, wherein the relative positions of the needle and the work at this time are represented. On the return movement of the cams the part n of the lifting-cam takes effect to still further raise the needles for taking the thread 5 again to form new loops, about as indicated in Fig. 11. Then the drawing-cam k moves onto the shanks to force the needles down, as indicated in Fig. 3, with the new loop and to cast off the old loop. The shanks h of the needles then pass under the part n of the next lifting-cam and onto part m , on which they are again raised to the intermediate position, as at starting; but in first starting up the machine when there is no fabric on the needles the needles will be in the lowermost position and will be raised therefrom by part m of the lifting-cam.

The broad lower end of the drawing-cam has an important function in promoting the production of even and regular fabrics in that there are always two or more needles held down and pulling together against the stress of the fabric on the combs, holding the fabric more steadily and giving up in a less jerky manner, which results in more even and regular work and enables the machine to run faster.

It will be seen that the lifting-cams being relatively arranged with the drawing-cams to raise the needles and set them in the intermediate position after completing the stitches and preparatory to making the next stitches avoids the harder thrusts necessary when the needles remain in the lower position to be raised the whole distance at one stroke.

As commonly arranged the drawing-cams are the last to pass the shanks of the needles, leaving them in the lowermost positions; but they are apt to be drawn up somewhat after the cam passes by the tension of the fabric on the comb and must be forced down again by the drawing-cam first passing over them before the lifting-cam reaches them, which practically amounts to redrawing the previously-formed stitches at a considerable waste of power and unnecessary stresses on the fabric, causing liability of dropping stitches and making less even and regular work. This is avoided by my improvements in the cams, which also enable the machine to run faster and make better work.

What I claim as my invention is—

1. The combination with a drawing-cam both sides of which are adapted for drawing the needles the full range of their drawing movement, and a lifting-cam to each side of the drawing-cam, said lifting-cams each comprising two separate parts both of which serve in lifting the needles in advance of the drawing-cam, and one lifts them to and leaves them

in the intermediate position behind the drawing-cam, the other part being inoperative in the retiring movements of the cams.

2. The combination of two cams both sides
5 of which are adapted for drawing the needles the full range of their drawing movement, an intermediate lifting-cam comprising three parts and adapted to lift the needles to and in advance of both drawing-cams respectively,
10 and a lifting-cam to the outer side of each drawing-cam.

3. The combination of two cams both sides of which are adapted for drawing the needles the full range of their drawing movements, an
15 intermediate lifting-cam comprising three parts, and adapted to lift the needles to and in advance of the drawing-cams respectively, and a lifting-cam to the outer side of each drawing-cam, comprising two separate parts,
20 both of which serve in lifting the needles in advance of the drawing-cams respectively, and one lifts them to and leaves them in the intermediate position behind the drawing-cams, the other part being inoperative in the
25 retiring movements of the cams.

4. The combination with a drawing-cam

both sides of which are adapted to draw the needles the full range of their drawing movement, of a lifting-cam to each side of the drawing-cam comprising two separate parts, one
30 of which is adapted to lift the needles to the intermediate position in both the forward and backward movements, and the other part is adapted to lift the partly-raised needles up to the thread-receiving position in the forward
35 movement and is inoperative in the retiring movement.

5. The combination with a drawing-cam adapted for drawing the needles the full range of their drawing movement, of a lifting-cam
40 comprising two parts one of which lifts the needles to the intermediate position both in the forward and returning movements, and guards over said part of the lifting-cams.
45

Signed by me at New York, N. Y., this 5th day of August, 1899.

HERMANN A. KLEMM.

Witnesses:

A. P. THAYER,
C. SEDGWICK.