

(No Model.)

7 Sheets—Sheet 1.

J. G. SCHREUDER.  
SWITCH APPARATUS.

No. 526,328.

Patented Sept. 18, 1894.

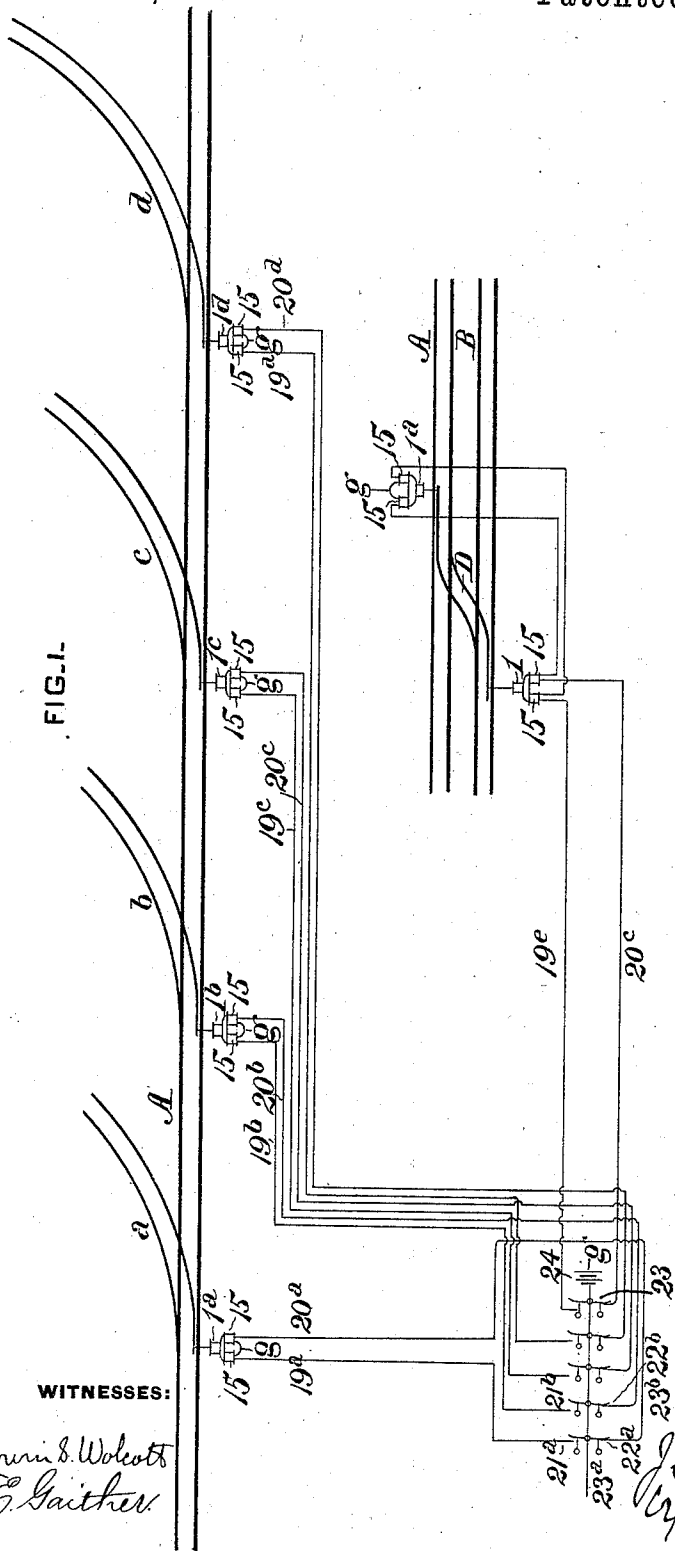

WITNESSES:

*Darius S. Wolcott*  
*D. C. Gaither*

INVENTOR,

*Jess G. Schreuder*  
*By George N. Christy*  
Att'y.

(No Model.)

7 Sheets—Sheet 2.

J. G. SCHREUDER.  
SWITCH APPARATUS.

No. 526,328.

Patented Sept. 18, 1894.

FIG. 2.

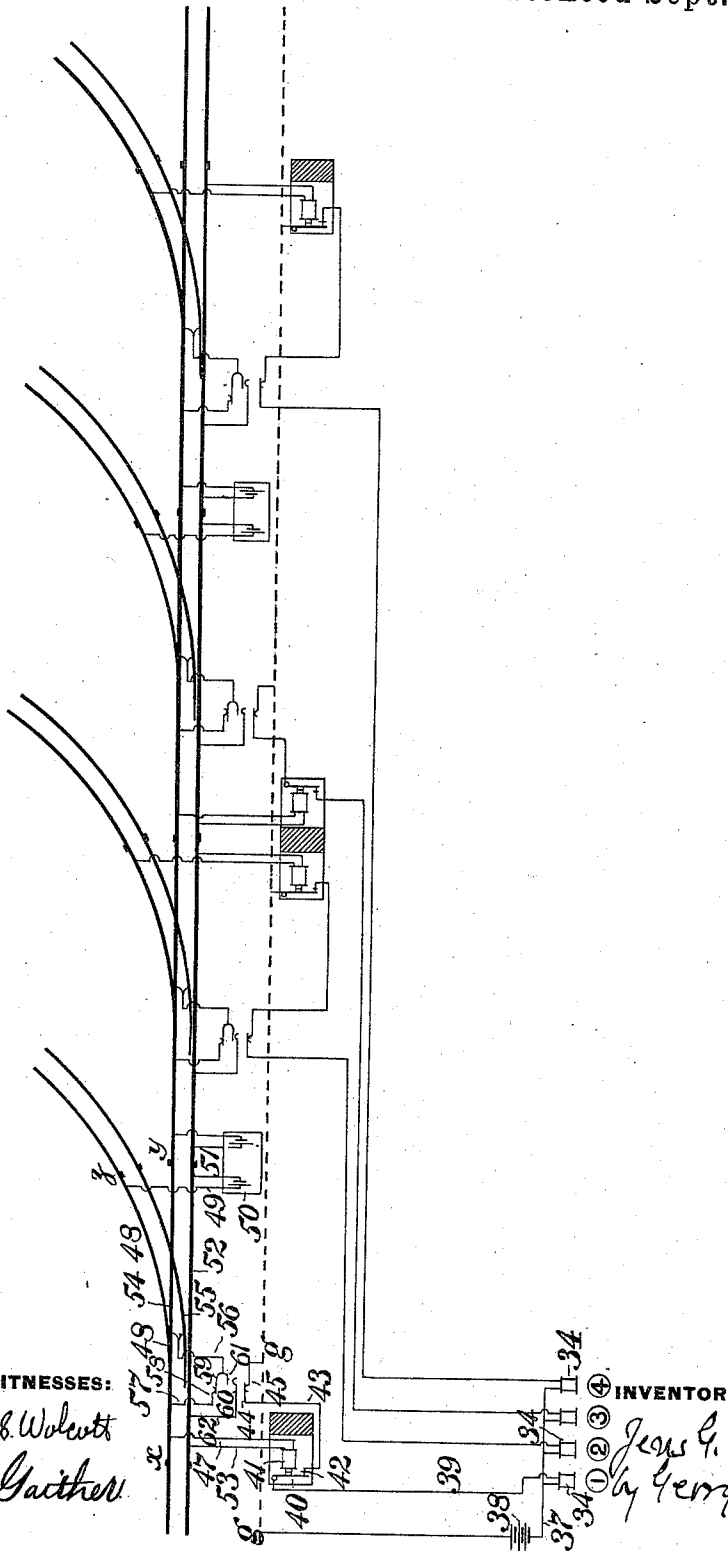

WITNESSES:  
*Darwin S. Wolcott*  
*F. C. Gaither*

INVENTOR,  
*Jos. G. Schreuder,*  
 by *Gerrit H. Christy*  
 Att'y.

J. G. SCHREUDER.  
SWITCH APPARATUS.

No. 526,328.

Patented Sept. 18, 1894.

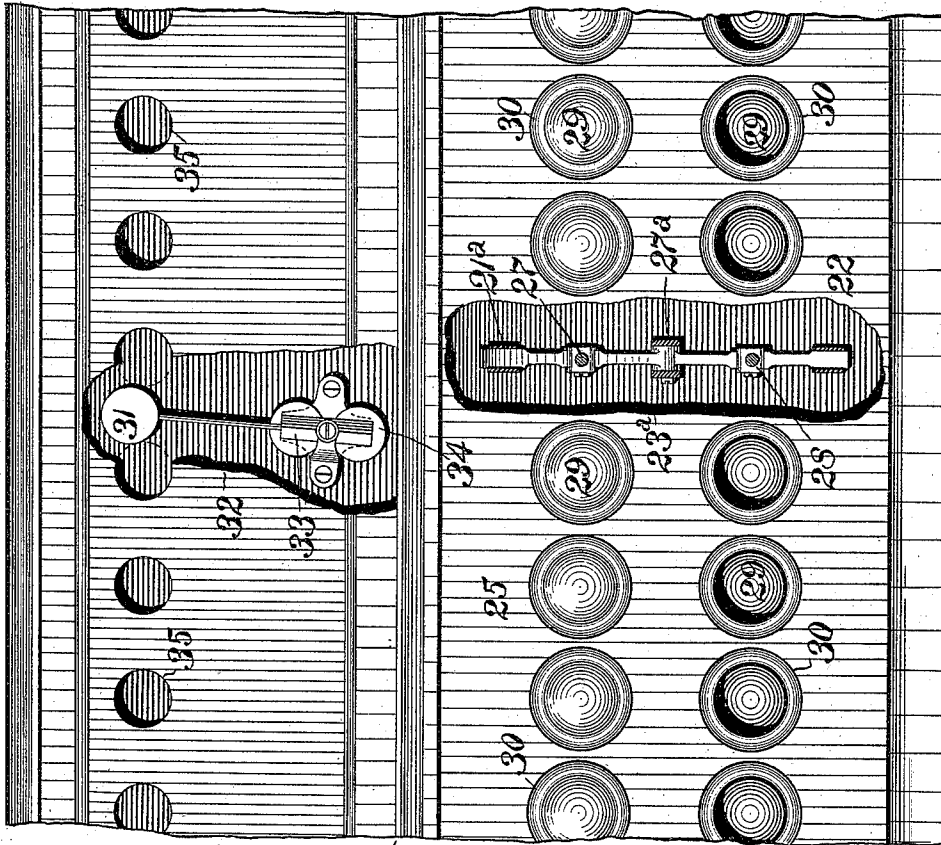

FIG. 4.

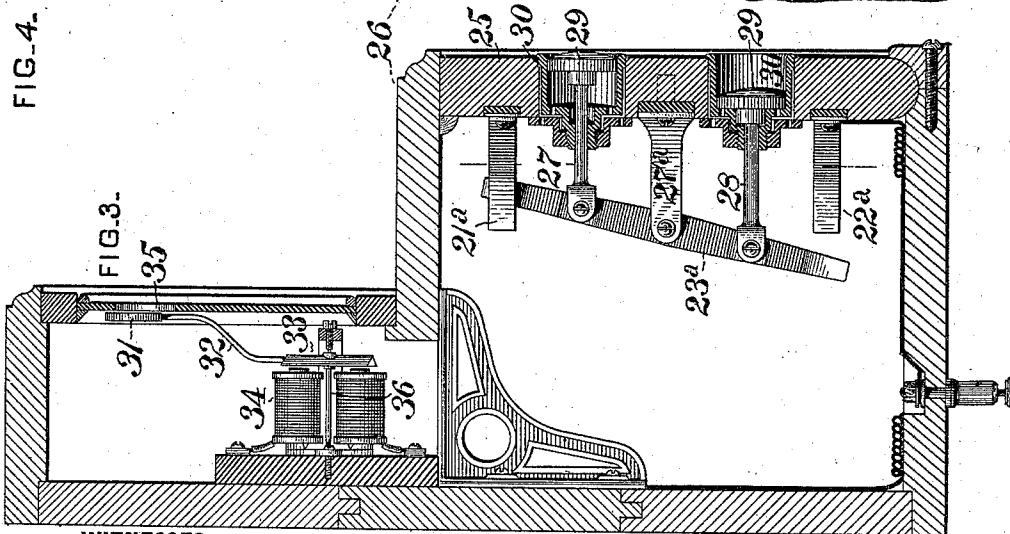

FIG. 3.

WITNESSES:

INVENTOR,

*Darius B. Wolcott*  
*F. C. Gaither.*

*Jess G. Schreuder,*  
*by George H. Christy*  
Att'y.

(No Model.)

7 Sheets—Sheet 4.

J. G. SCHREUDER.  
SWITCH APPARATUS.

No. 526,328.

Patented Sept. 18, 1894.

FIG. 5.

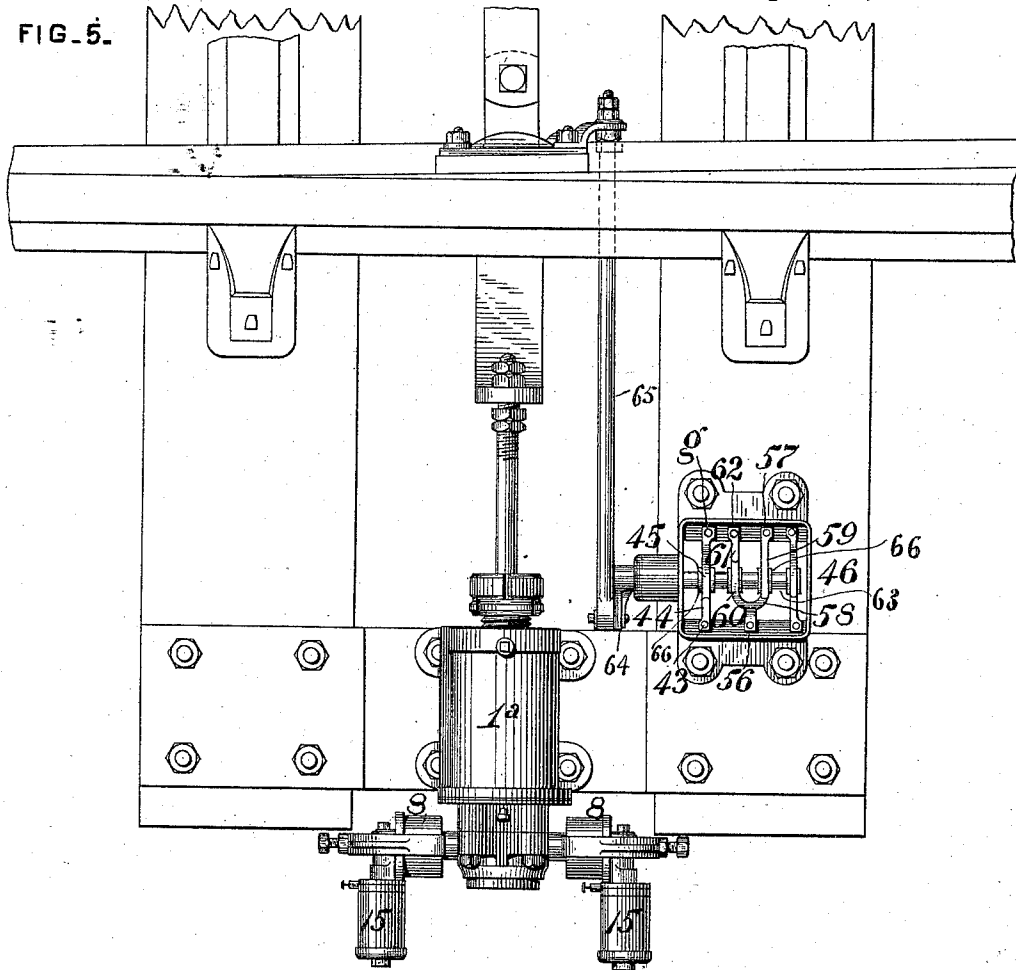
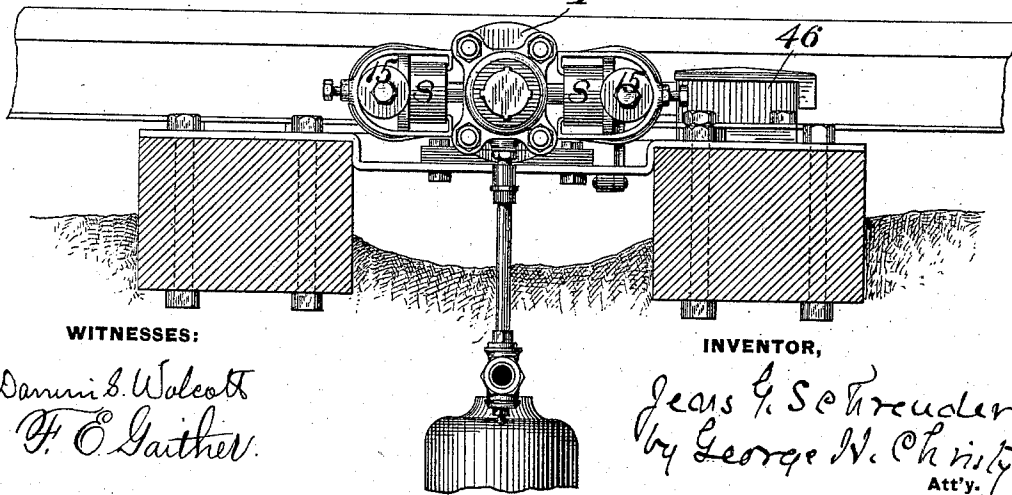

FIG. 6-10



WITNESSES:

*Darius S. Wolcott*  
*F. C. Gaither*

INVENTOR,

*J. G. Schreuder*  
by *George W. Christy*  
Att'y.

(No Model.)

J. G. SCHREUDER.  
SWITCH APPARATUS.

7 Sheets—Sheet 5.

No. 526,328.

Patented Sept. 18, 1894.

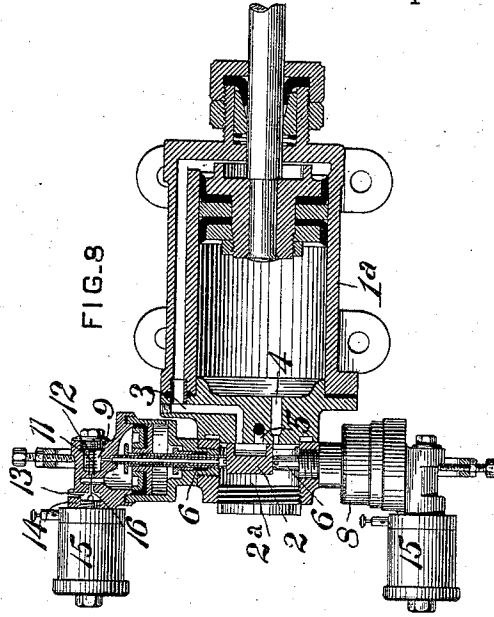
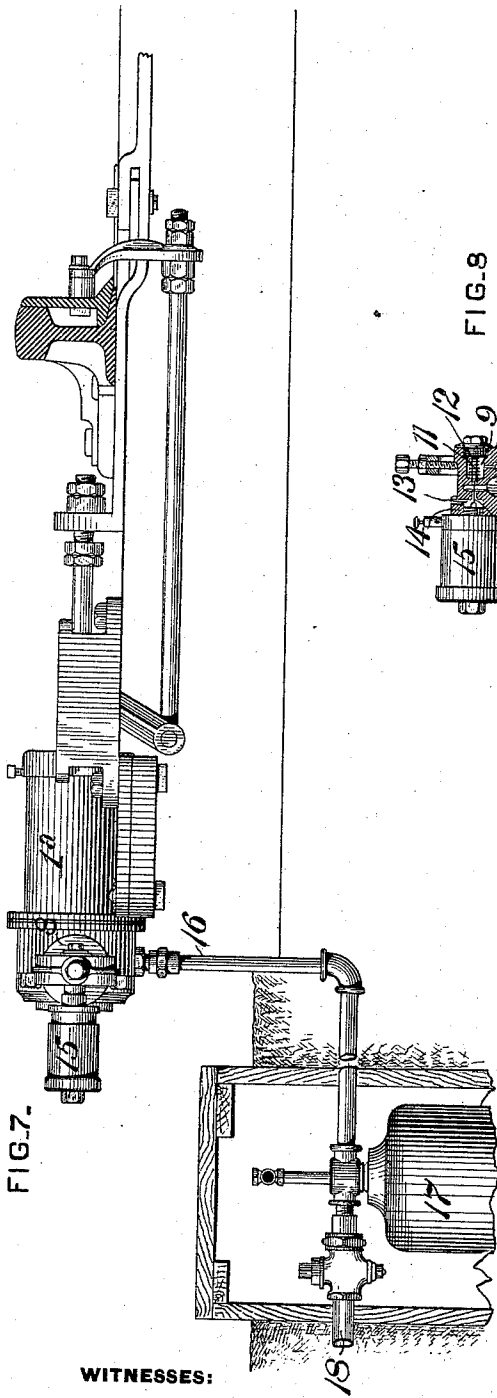

FIG. 7.

FIG. 8.

WITNESSES:

*Darius B. Wolcott*  
*F. O. Gaither*

INVENTOR,

*J. G. Schreuder,*  
*by George H. Christy*  
Att'y.

(No Model.)

7 Sheets—Sheet 6.

J. G. SCHREUDER.  
SWITCH APPARATUS.

No. 526,328.

Patented Sept. 18, 1894.

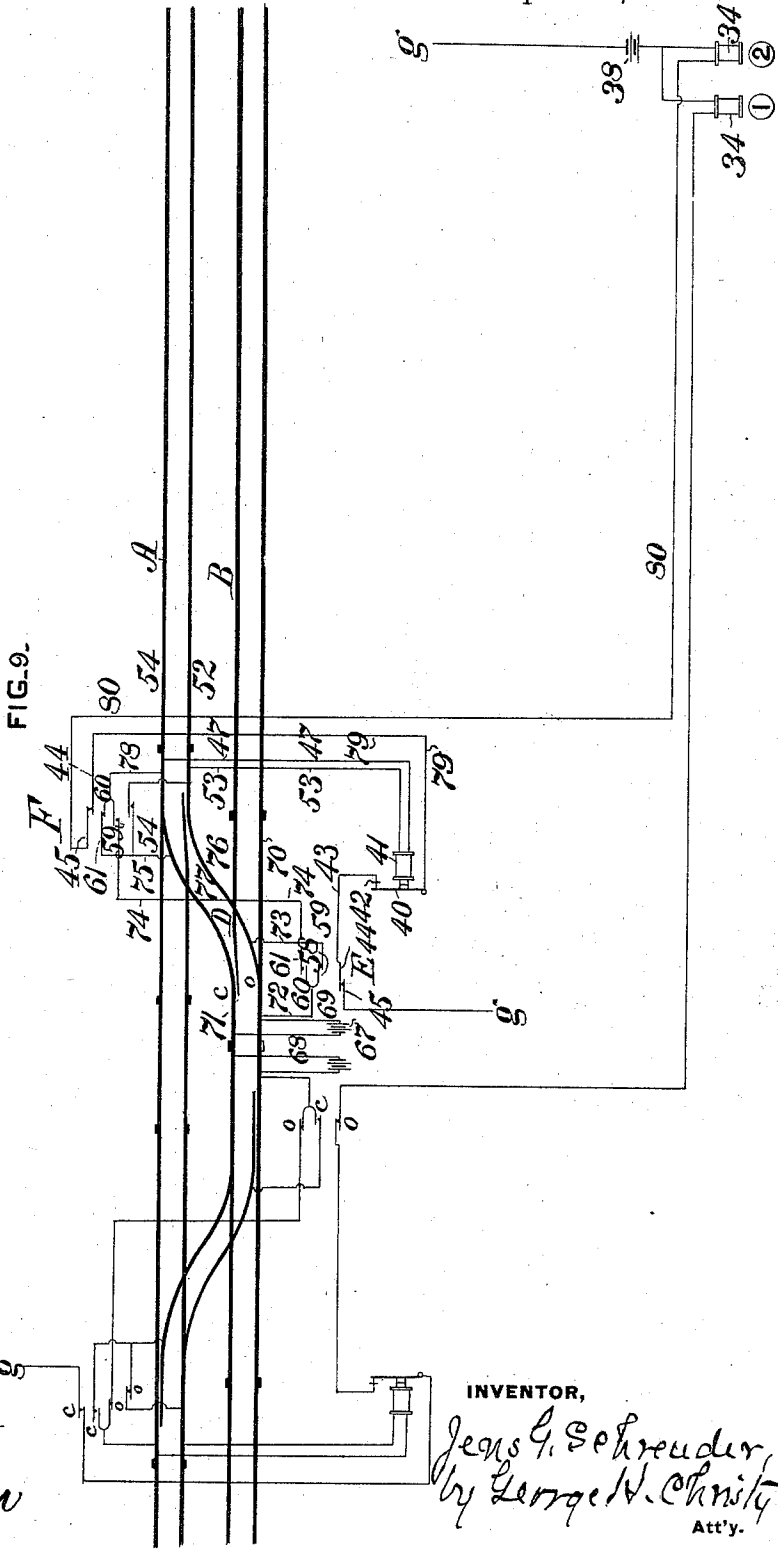

WITNESSES:  
*Daniel S. Wolcott*  
*H. O. Gauthier*

INVENTOR,  
*Jean G. Schreuder*  
by *George W. Christy*  
Att'y.

(No Model.)

7 Sheets—Sheet 7.

J. G. SCHREUDER.  
SWITCH APPARATUS.

No. 526,328.

Patented Sept. 18, 1894.

FIG. 9.

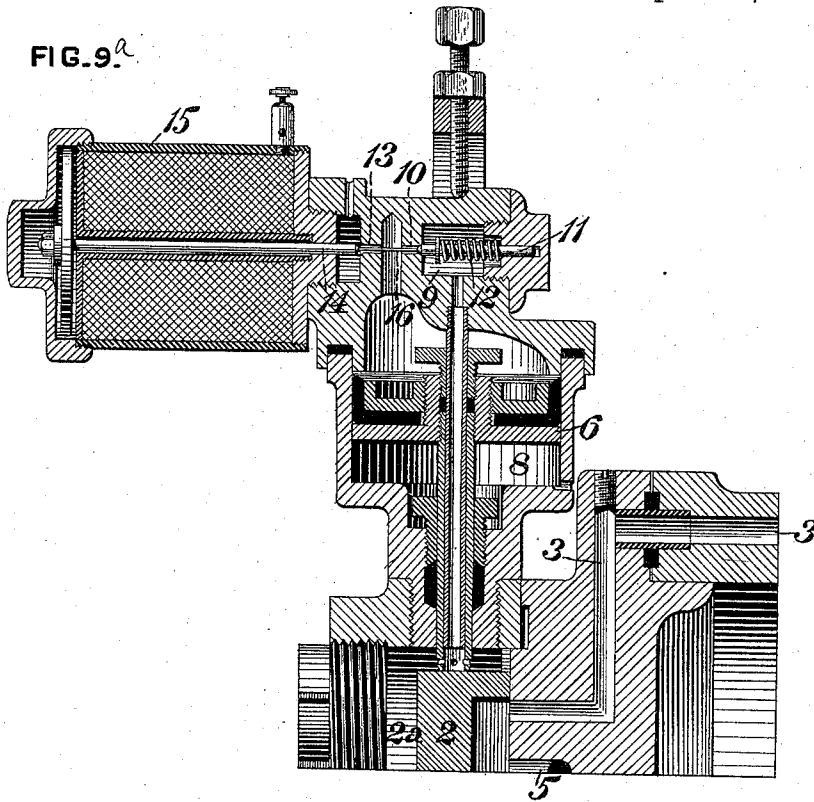

FIG. 10. 46

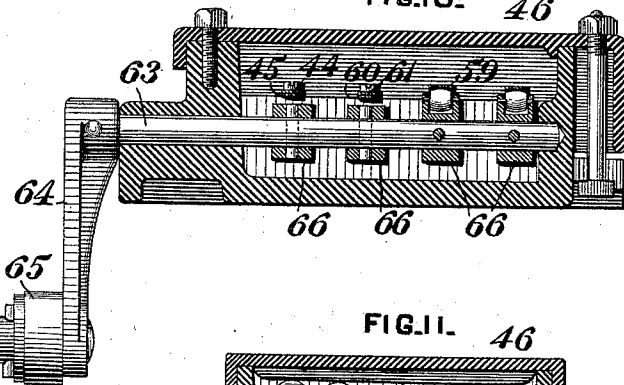
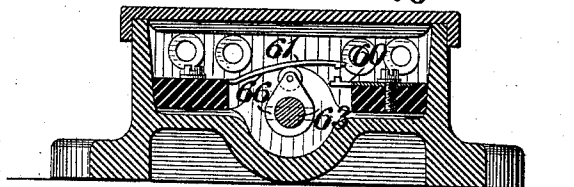

FIG. 11. 46



WITNESSES:

*Daniel S. Wolcott*  
*J. C. Gaither*

INVENTOR,

*Jas. G. Schreuder*  
*by George H. Christy*  
Att'y

# UNITED STATES PATENT OFFICE.

JENS G. SCHREUDER, OF WILKINSBURG, PENNSYLVANIA.

## SWITCH APPARATUS.

SPECIFICATION forming part of Letters Patent No. 526,328, dated September 18, 1894.

Application filed June 10, 1892. Serial No. 436,233. (No model.)

*To all whom it may concern:*

Be it known that I, JENS G. SCHREUDER, a subject of the King of Sweden and Norway, residing at Wilksburg, in the county of Allegheny and State of Pennsylvania, have invented or discovered certain new and useful Improvements in Switch Apparatus, of which improvements the following is a specification.

The invention described herein relates to certain improvements in mechanism for operating, in due succession, a series of switches of a like series of sidings extending from a common main track, such arrangement of main track and sidings forming what is known as a "ladder" and employed for distributing the cars of a train at terminals in accordance with their subsequent destination.

In general terms the invention consists in the construction and combination substantially as hereinafter described and claimed.

In the accompanying drawings forming a part of this specification, Figure 1 is a plan view showing the arrangement of tracks in a ladder, and the circuits leading from the tower to the switch operating mechanism, which said circuits control. Fig. 2 is a similar view of the tracks and showing the arrangement of indicating circuits whereby the position of the switches may be shown to the operator in the tower. Fig. 3 is a sectional elevation of the mechanism in the tower for making and breaking the circuits controlling the switches and the indicating mechanism controlled by the signal circuits. Fig. 4 is a front elevation of a portion of the mechanism controlling the circuit and of the indicating mechanism, a portion of the front of the frame being broken away. Fig. 5 is a plan view of the switch operating mechanism. Figs. 6 and 7 are end and side elevations of the same. Fig. 8 is a sectional view of the fluid pressure cylinder and its valve mechanism. Fig. 9 is a view similar to Fig. 2 showing the indicating circuits for a cross-over. Fig. 9<sup>a</sup> is a view partly in section and partly in elevation of the valve mechanism of the switch motor. Figs. 10 and 11 are sectional views, on an enlarged scale, of the electric switch mechanism shown in Fig. 5, the plane of section of Fig. 10 coinciding with the axis of the shaft of said switch,

and the plane of section of Fig. 11 being at right angles to said shaft.

In the practice of my invention, the movable rails of the respective sidings or switches *a, b, c, d, &c.*, extending from the main track *A*, are connected in the usual manner to the pistons of the fluid pressure cylinders 1<sup>a</sup>, 1<sup>b</sup>, &c., as shown in Figs. 1 and 8. On the outer ends of these cylinders are formed valve chambers 2<sup>a</sup>, in which are arranged valves 2 controlling the flow of fluid pressure through the ports 3 and 4 extending respectively to opposite ends of the cylinders, and the exhaust port 5.

The valves 2 are shifted as required by the pistons 6 in the cylinders 8 on opposite sides of the main valve chamber. Fluid pressure flows from the main valve chambers 2<sup>a</sup> through the hollow rods of the pistons 6, and tubes fitting in said piston rods, into the chambers 9, and thence by ports 10 into the outer ends of the cylinders 8. The flow of fluid pressure through the ports 10 is controlled by valves formed in the upper ends of rods 11 and are normally held to their seats by springs 12 surrounding said rods. Fluid pressure escapes from the outer ends of the cylinders 8 through ports 13, and is controlled in such escape by the valves on the lower end of the rods 14 extending through the electro-magnet inclosed in the shells 15 and connected at its upper end to the armature of said magnet as fully shown and described in Letters Patent No. 479,666, granted to me July 26, 1892. A pin 16 is interposed between the ends of the rods 11 and 14 so that the springs 12 serve not only to seat the valves in the ends of the rods 11, but also to unseat the valves on the lower ends of the rods 14 and to raise the armatures on the upper ends of said rods 14. When the magnets are excited the valves on the rods 14 will be seated, closing the exhaust ports 13 and the valves on the rods 11 will be unseated, allowing fluid pressure to flow to the outer ends of the cylinders 8.

It will be understood the circuits of the electro-magnets on each of the fluid pressure motors is so connected to make and break mechanism (to be hereinafter described) that when the circuit of one of the magnets is

closed, the circuit of the other magnet is broken.

The valve chambers 2<sup>a</sup> are connected by pipes 16 to reservoirs 17 containing fluid under pressure and said reservoirs are connected to supply pipe 18, but if desired the valve chambers 2<sup>a</sup> may be connected directly to the supply pipe.

The electro-magnet of each switch operating motor have one terminal grounded as shown in Fig. 1, while the other terminals are connected by wires 19<sup>a</sup>, 20<sup>a</sup>, 19<sup>b</sup>, 20<sup>b</sup>, &c., to contacts 21<sup>a</sup> and 22<sup>a</sup>, 21<sup>b</sup> and 22<sup>b</sup>, &c., located in such proximity to each other in the operating machine, that electric switches 23<sup>a</sup>, 23<sup>b</sup>, &c., may be shifted into electric connection with such contacts as will be hereinafter described. These electric switches are connected to one pole of the battery 24, whose opposite pole is grounded.

From the foregoing it will be seen that by shifting the electric switch so as to close the circuit through one of the magnets of one of the motors and at the same time breaking the circuit through the other magnet of the same motor, the switch rails can be shifted as desired.

As shown in Figs. 3 and 4, the contacts 21<sup>a</sup> and 22<sup>a</sup>, &c., are constructed in the form of standards attached to the inner side of the front board 25 of the frame 26 suitably arranged in the signal tower. The free ends of the standards are forked and the fingers thus formed have sufficient resiliency to have a spring bearing against the sides of the electric switch or levers 23<sup>a</sup>, 23<sup>b</sup>, &c. These switches or levers are pivotally mounted on posts 27<sup>a</sup> also attached to the front board 25 and said posts are connected, as shown in Fig. 1, to a pole of the battery 24. Pins 27 and 28 are connected to the switches or levers 23<sup>a</sup>, &c., on opposite sides of the pivotal point, and extending out through the front board are provided at their outer ends with heads 29. As shown in Figs. 3 and 4, the front board is provided with a series of sockets 30 in which the heads 29 move, the sockets being of a depth approximately equal to the movements of the heads, so that the latter are within the sockets at all times and hence are not liable to be shifted accidentally.

In order that the operator may know the position of the switch rails, the portions of the main track occupied by cars, and also that cars have passed sufficiently far into the siding as to be clear of cars passing along the main track, electrically controlled indicating devices are arranged in the tower preferably immediately above the push buttons for operating the switches as hereinbefore described. These indicating devices consist of disks 31 secured to the upper ends of rods 32 which are attached to the armatures 33 of the electro magnets 34. These magnets are secured to the back board of the inclosing

frame at a slight angle, as shown in Fig. 4, so that when the magnets are demagnetized, the disks will drop in front of the openings 35 in the front board of the frame. As shown in Figs. 3 and 4, the armatures 33 are triangular in cross-section, and are pivotally mounted midway of their lengths on pins 36, so that when the magnets are excited the armatures will be shifted so that their apices will lie over the axes of the magnets, by which movement the disks 31 will be moved from in front of the openings 35.

As shown in Fig. 2, one pole of the magnets 34 is connected by a wire 37 to one pole of the battery 38, the opposite pole of the battery being grounded. The other pole of the magnet 34 is connected by the wire 39 to one end of the armature 40 of the electro magnet 41, the other portion of this circuit being formed by the contact point 42, the wire 43, the contact plates 44 and 45 in switch 46, the contact plate 45 being grounded.

The circuit of the electro magnet 41, is formed by wire 47, main and siding rail 48, wire 49, battery 50, wire 51, main rail 52, and wire 53.

It will be observed that the movable rails 54 and 55 are connected by wires 56 and 57, and contact plates 58 and 59 of switch 46, to main and siding rail 48, so that when said movable rails are shifted for clear main line, they will have the same polarity as such main and siding rail, but when the rails 54 and 55 are shifted to open siding the contact plates 58 and 59 are separated, and the contact plates 60 and 61 of the switch are brought together, so that, as the contact plate 61 is connected by wire 62 to main rail 52, the movable rails 54 and 55 have the polarity of the main rail 52.

From the foregoing it will be readily understood that the presence of a car on the main rails between the insulating points  $x-y$  will cut out the magnet 41, the current from the battery passing through the wheels and axles of the car and that the presence of a car between the insulating points  $x, z$ , when the movable rails are set for opening siding will also break the circuit through the magnet 41. The demagnetization of the magnet will permit the armature 40 to move away from the contact point 42, thereby breaking the signal circuit and permitting the disk 31 to swing into line with its opening in the front board.

The construction of the electric switch 46 is shown in Fig. 5, and consists of a shaft 63 provided with a crank arm 64 connected by a rod 65 to the movable switch rails. On the shaft are formed cams or projections 66 adapted to force the spring contact plates hereinbefore referred to, together and permit of their separation in certain predetermined order. As for example, the cams or projections 66 are so adjusted that when the movable switch rails are at normal or clear main line the contact plates 44 and 45 of the signal circuit are held together, and also the plates

58 and 59 of the track circuit. As the switch rails move to open siding, the contact plates 44, 45 and 58, 59, are allowed to separate and the plates 60 and 61 are forced together, but as soon as the movable rails are again shifted and complete their movement to clear main line the contact plates 44 and 45 of the signal circuit are again pressed together.

As hereinbefore stated, the purpose of the switch in the track circuit is for changing the polarity of certain portions of the rail, and this change of polarity may be effected without breaking the track circuit. Hence, the switch in the signal circuit formed by contact plates 44 and 45 is employed to indicate to the operator that the switch rails have been shifted. The circuit being broken during the movement of the switch rails, the disk 31 will appear at its opening.

The signal and track circuits for each of the sidings forming the "ladder" are the same and the component parts are indicated by the same numerals as those employed in describing the circuits for siding *a*, with the index letter of the siding annexed thereto.

When it is desired to distribute the cars of a train to the several sidings in accordance with their ultimate destination, a list showing the numbers of the cars and their respective destinations is given the operator in the tower. By consulting this list as the cars pass in front of the tower, he will ascertain onto which siding the car or cars should be run. Then he simply presses the proper button so as to close the circuit through the switch operating mechanism. The appearance of the signal disk at its opening for a short time, will indicate that the switch has been shifted. The appearance of the disks at their openings in regular sequence will indicate the passage of the car along the main track, and the entire disappearance of the disks will indicate that the car or cars have passed into the siding beyond the fouling point, so that other cars may be moved to sidings farther along the main track.

It will be understood that when cars have been started for one of the distant sidings, other car or cars may be allowed to pass to intermediate sidings without waiting until the first car has reached its siding.

As the progress of the car along the main track is indicated by the successive appearance of the disks and as the non-appearance of any of the disks indicates that the car has passed beyond the fouling point of a siding, it is only necessary that the tower should be so located that the operator may see the cars before they arrive at the first siding of the ladder.

Where the several sidings forming the "ladder" extend from one of two main line of tracks A, B, it is necessary to provide a cross over from the track B to the track A, as shown in Fig. 1. In such case the movable switch rails at each end of the cross-over D, are operated by fluid pressure motors con-

structed as hereinbefore described. In order to secure synchronous movements of these fluid pressure motors, their electro magnets are included in the same circuit, which is controlled by one switch 23, as shown in Fig. 1.

In arranging the signaling circuits for this cross-over, the battery 67 is connected by wires 68 and 69 to the rails 70 and 71 of the track B, as shown in Fig. 9. The rail 70 is connected by the wire 72 with the plate in the switch box indicated at E, having the contact points 58 and 60, which are alternately shifted into contact by the movement of the movable rails of track B, with the plates 59 and 61. The plate 59 is connected by the wire 73 with the cross-over rails 76 and the plate 61 is connected by the wire 74 to the contact plate 59 of the switch box indicated at F.

The contact plate 61 of the box F is connected by the wire 75 to the other cross-over rail 77. The double contact plate of this box is connected by the wire 78 to the rail 54 of the track A. This rail 54 is connected by the wire 47 to one pole of the relay magnet 41, and the other pole of said magnet is connected by the wire 53 to the rail 52. The armature 40 of this relay is connected by the wire 79 to the contact plate 44 of the switch box F and its companion plate 45 is connected by the wire 80 to one pole of the signal magnet 34, whose other pole is connected to one pole of the battery 38, the opposite pole of the battery being grounded. The contact point 42 of the relay 41, is connected by a wire 43 to the contact plate 44 of the switch box E, and the companion plate 45 is grounded.

By reference to Fig. 9, it will be seen that when the movable rails of the cross-over are shifted so as to allow of the passage of cars from track B to track A, the wire 68, main and cross-over rails 71 and 77, wires 75 and 78, main rail 54, and wire 47, are of one polarity, while the wire 69, main and cross-over rails 70, and 76, wires 72 and 59, main rail 52 and wire 53 are of the opposite polarity.

While the track A may be employed for the main traffic of a road, it is generally a siding from the main track, or track in a yard employed as the main distributing track of the several sidings *a*, *b*, &c.

I claim herein as my invention—

1. The combination of a main track, a series of two or more sidings extending therefrom mechanisms operative from a central station for shifting the movable rails of each of said sidings independent of the others, a series of two or more track circuits including the main and siding rails adjacent to the junction of the siding with the main track, a series of two or more indicators located in the central station and a series of two or more signal circuits for operating the indicators and controlled by the track circuits, whereby the movements of the cars along the main track and into the sidings may be indi-

cated to the operator at the central station, substantially as set forth.

2. In a switch apparatus, the combination of movable switch rails, a motor for operating said rails, two circuits extending from said motor to suitable contact plates, a centrally pivoted lever adapted to be shifted into engagement with one or the other of said contact plates, and push rods connected to the

lever on opposite sides of its pivotal point, substantially as set forth.

In testimony whereof I have hereunto set my hand.

JENS G. SCHREUDER.

Witnesses:

W. B. CORWIN,  
DARWIN S. WOLCOTT.