

[54] **SETTABLE KEY AND CODING MECHANISM THEREFOR**

[72] Inventor: **Marvin E. Roberts**, Reno, Nev.
[73] Assignee: **Locking Systems, Inc.**, Reno, Nev.
[22] Filed: **May 28, 1970**
[21] Appl. No.: **41,211**

[52] U.S. Cl.70/411, 29/208 C, 70/395, 70/399, 70/408, 340/306
[51] Int. Cl.E05b 19/18
[58] Field of Search.....70/411, 409, 408, 393, 395, 70/396, 399, 431, 447, 460, 382-384; 340/306; 33/174 F

[56] **References Cited**

UNITED STATES PATENTS

1,446,760 2/1923 Miller70/334
3,142,167 7/1964 Christopher70/411

FOREIGN PATENTS OR APPLICATIONS

620,053 10/1935 Germany70/411

Primary Examiner—Robert L. Wolfe
Attorney—Flehr, Hohbach, Test, Albritton & Herbert

[57] **ABSTRACT**

A system for selectively coding a key to correspond to the code for any one of a number of differently coded locks is provided whereby the key is set to operate any given one of the locks. The key includes settable bits carried upon a shank or stem each of the bits being variously settable to a number of coded arrangements thereof. The key setting means serves to set the bits of the key in response to a coding element having predetermined code portions defining the code for the lock which is to be operated. For example a punched hole accounting card can be utilized as a coding element. The setting means receives a key and also the coding element and includes sensing portions for sensing the coded portions of the coding element so as to set the key bits in response thereto.

13 Claims, 13 Drawing Figures

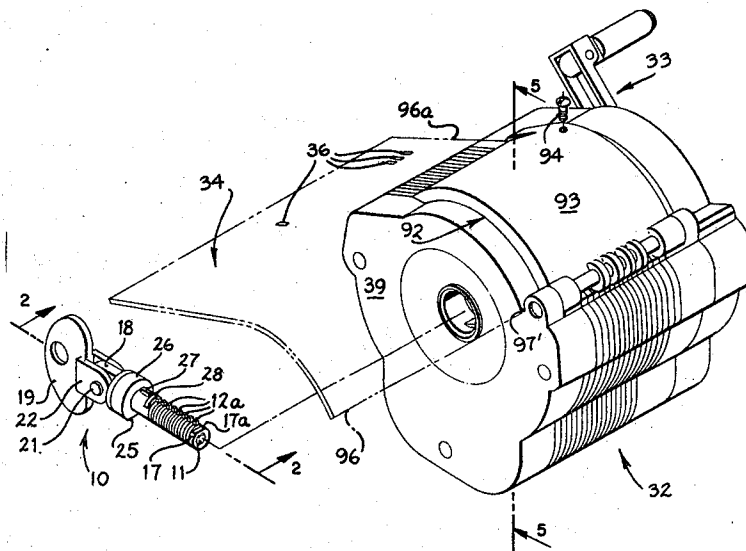

FIG 4

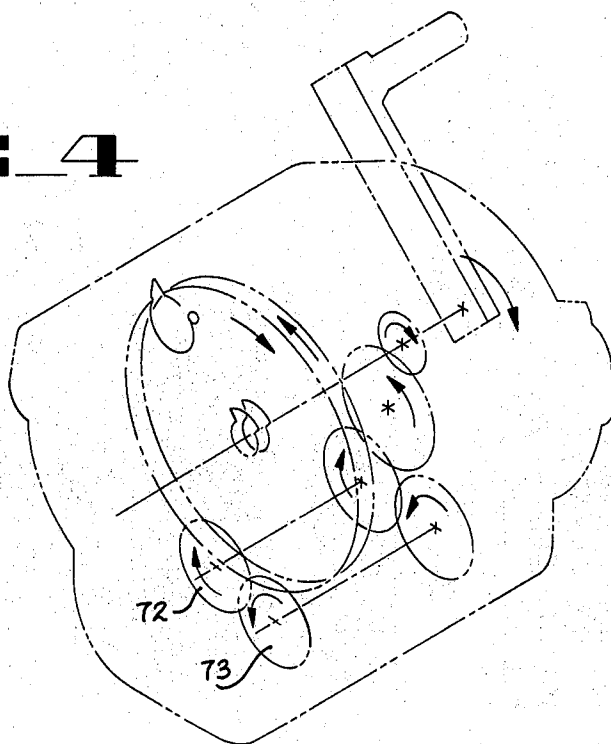

FIG 5

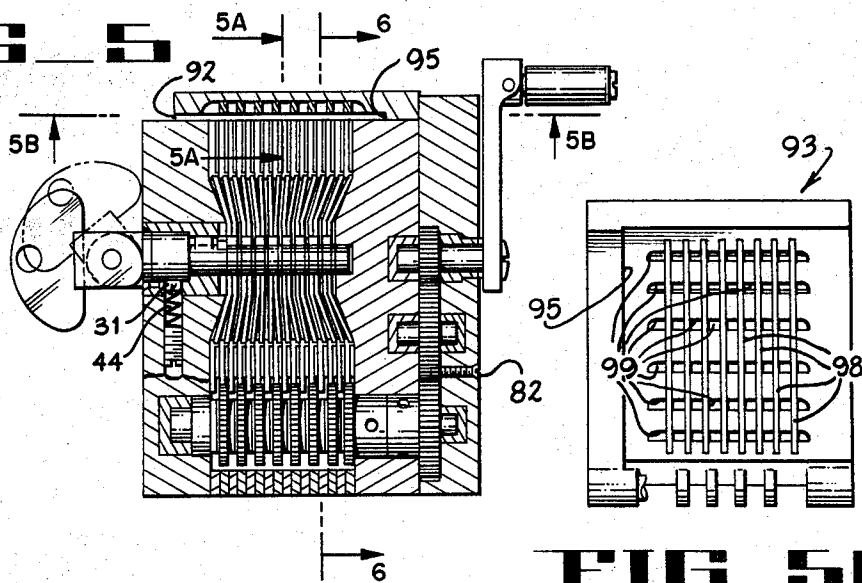

FIG 5B

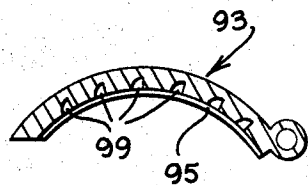

FIG 5A

INVENTOR
MARVIN E. ROBERTS
BY *Fleish, Hohbach, Test,
albritton & Herbert*
ATTORNEYS

FIG 6

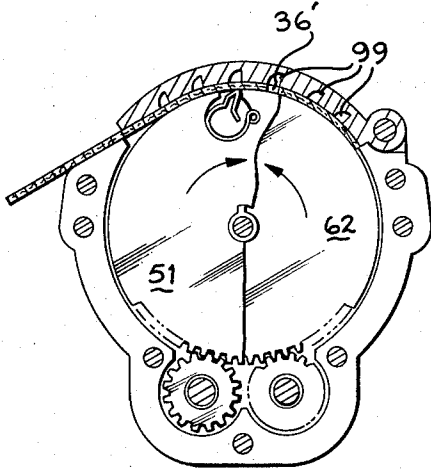
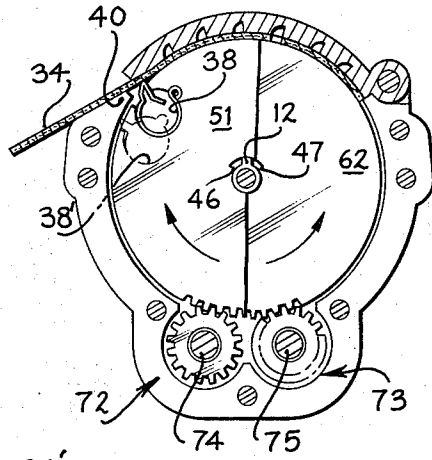

FIG 7

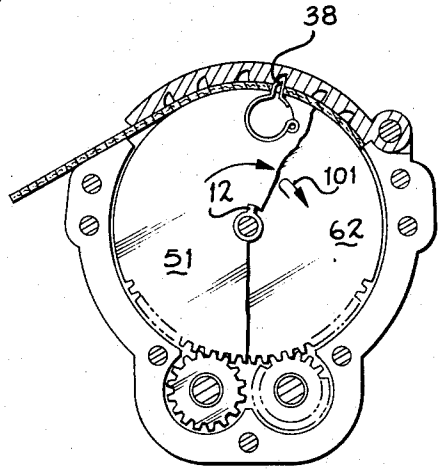

FIG 8

INVENTOR
MARVIN E. ROBERTS

BY *Flehr, Hohbach, Test,
Albritton & Herbert*
ATTORNEYS

SETTABLE KEY AND CODING MECHANISM THEREFOR

BACKGROUND OF THE INVENTION

This invention pertains to a settable key and coding mechanism for setting the key to operate any one of a number of differently coded locks.

Heretofore, where a service man has been required to service a number of vending machines, or the like, he has been required to carry a large number of keys with each one being unique to a given vending machine.

In general this requirement has led to a somewhat cumbersome operation in handling keys for any extended route or extended number of machines required to be serviced.

For various reasons the use of a single master key common to the coding characteristics of a large number of locks has not been satisfactory in this and various other applications.

Accordingly, there has been a need for the provision of a single key settable to various differently coded conditions for operating any one of a number of variously coded locks.

SUMMARY OF THE INVENTION AND OBJECTS

In general it is an object of the present invention to provide an improved key for operating a number of variously coded locks.

It is another object of the present invention to provide an improved coding mechanism for selectively coding a key to correspond to the code of any one of a plurality of differently coded locks so as to selectively operate a given one of the locks.

The foregoing and other objects will become more readily apparent from the following detailed description of a preferred embodiment having in mind the following general description.

A system has been provided for selectively coding a key to correspond to the code of any one of a plurality of differently coded locks so as to operate a given one of the locks. The system includes key means having bits settable variously to a number of coded arrangements thereof. A punched hole accounting card or other perforated substrate carrying openings therein defining the code for a given one of the locks to be operated is utilized and setting means for receiving the substrate and key have been provided together with means serving to set the key bits in response to the openings of the card.

BRIEF DESCRIPTION OF THE DRAWINGS

FIG. 1 is a perspective view showing a key of a type to be selectively set to correspond to the code of any one of a plurality of differently coded locks and further showing a mechanism for setting the key to a given one of the locks;

FIG. 2 is a side elevation in section taken along the line 2—2 of FIG. 1;

FIGS. 2A, 2B and 2C are elevation sections in enlarged detail taken along the lines 2A—2A, 2B—2B, and 2C—2C respectively of FIG. 2;

FIG. 3 is an exploded perspective view of the key coding mechanism shown in FIG. 1;

FIG. 4 is a perspective diagrammatic view for illustrating the operation of a portion of the key coding mechanism shown in FIG. 1;

FIG. 5 is a side elevation center line section view taken along the line 5—5 of FIG. 1;

FIG. 5a is a detail section view of FIG. 5 taken along the line 5a—5a of FIG. 5;

FIG. 5b is a detailed view of the lid of the mechanism shown in FIG. 5 taken along the lines 5b—5b;

FIGS. 6, 7, and 8 are all section views taken along the lines 6—6 of FIG. 5 and showing a portion of the setting mechanism in successive stages of movement.

DESCRIPTION OF A PREFERRED EMBODIMENT

In the system disclosed herein for selectively coding a key to correspond to the code of any one of a plurality of differently

coded locks, a universal key assembly 10 comprises at one end an elongated shank or stem portion 11 consisting of a plurality of bit elements 12 each mounted to rotate through a limited arc at spaced intervals along the stem and having radially outwardly extending portions 12a. In addition, means are provided which are operable from the other end of the key assembly 10 for selectively locking or releasing the bits 12 in their respective relative arcuate positions.

More particularly each bit element 12 further includes a radially inwardly projecting tab 12b disposed to limit the arcuate movement of element 12 about shank 11 as tab 12b rides in a longitudinally extending groove 14 formed along shank 11.

Bit elements 12 are disposed at spaced intervals along shank 11 by means of spacers 16 of generally annular configuration carried about shank 11 and locked from rotating on shank 11 by engagement of a radially inwardly protruding portion 16a (FIG. 2B) arcuately filling the arc 13 of slot 14. At its left end 17 (as shown in FIG. 2) shank 11 is enlarged to provide an end limit to longitudinal movement of bits 12 and spacers 16. A cut chord across approximately the top quarter of end portion 17 provides a registration flat 17a adapted to enter opening 69a (FIG. 3) when registered with a corresponding flat 69b formed therein.

In this manner the two flats 17a, 69b hold shank 11 from turning when the key assembly 10 is inserted within the setting mechanism 32.

The other end of shank 11 is formed to include a generally square shaped fixed head 18, shown best in FIG. 1, with one corner of its squared configuration rounded off, as at 18a. The bow 19 is pivotally supported by a pin 21 which extends through both sides of the yoke 22. The ends of yoke 22 are rounded in an eccentric manner to form surfaces to operate as a cam element carried by the bow and serving in the position shown in FIG. 2 to frictionally engage and compress the bit elements 12 into compacted relation and when moved in the direction of arrow 23 to release the bit elements for movement about shank 11.

Accordingly, a washer 24 is disposed about shank 11 between the cam surfaces of yoke 22 and a generally annular collar 26 rotatable through arc 13 (FIG. 2C) of the key assembly. Collar 26 encircles shank 11 and extends longitudinally therealong, including a rotational stop element 27 and a ward 28 suitable for use in conjunction with that type of lock disclosed in copending application, Ser. No. 37 filed Jan. 2, 1970 and entitled Lock Construction, assigned to the assignee herein.

When used in conjunction with the above identified lock construction, collar 28 supplies the added security feature that the key can be removed from the lock only after having scrambled the lock's tumblers. Thus, collar 26 serves to prevent the key assembly 10 from being withdrawn from the lock without (a) first having released the bow 19 in the direction of arrow 23 (thereby releasing the bit elements 12) and, (b) in addition, having turned the key in the lock to its limit of rotation in a direction opposite to the unlocking rotation. The reverse rotation of the key (shank 11) is required to continue until an interior dog portion 26a (FIG. 2C) has been carried by the driving side of groove 14 to the point where stop element 27 engages a fixed limiting portion of the lock.

During this reverse rotation of the key all bits 12 are reversely rotated by engagement of their tabs 12b with a common driving side of groove 14 and this movement serves to rotate the tumblers of the lock by engagement between bit portions 12a and a radial extension of the tumblers into the keyhole portion of the lock.

At the limiting position of reverse rotation an edge of all bit portions 12a will be aligned with an edge of ward 28 and ward 28 aligned with an arcuate portion of the keyhole of the lock whereby the key may be withdrawn from the keyhole of the lock with all bits 12 aligned.

At this position, the interior of the lock's tumblers will expose only an aligned group of radial extensions. However, the

unseen operative tumbler portions will have been scrambled to various positions thereby preventing compromise of the lock's code.

Thus, collar 26 is retained within the lock until ward 28 is aligned to be removed. At no other time can the key be removed, and at this position of alignment the lock's tumblers will necessarily have had to be scrambled.

The undersurface of collar 26 includes a flat 25 formed to incorporate a small dimple 29 adapted to receive a spring urged ball detent 31 (FIG. 5) whereby positive seating and registration of key assembly 10 within a translating or key setting mechanism 32 can be insured.

As thus arranged bow 19 of key assembly 10 is movable between advanced and retracted positions about an axis transversely of the axis of shank 11 in order to lock or release the bit elements 12 in their respective relative arcuate positions as set by translating mechanism 32. In the position shown in FIG. 2 key assembly 10 is arranged whereby the cam surfaces of yoke 22 bear solidly against washer 24 and serve to draw the end cap 17 and shank 11 to the right (as shown in FIG. 2) thereby compressing the bit elements 12 and spacers 16 so as to hold bit elements 12, collar 26, and shank 11 all in fixed positions relative to one another. The rounded corner 18a of the right hand end of head 18 accommodates the arcuate travel of bow 19.

Thus by simply employing the cam element function of yoke 22 operated by bow 19 the bit elements will be frictionally engaged between spacers 16 and retained in any arcuate condition set by mechanism 32, the spacers being non-rotatable on shank 11 by virtue of tabs 16a (see FIG. 2B) engaging groove 14.

In general, for setting the movable bit elements 12 of key assembly 10 to a selected combination of positions thereof there has been provided the mechanism 32 including a plurality of discrete bit positioning means individually operable for respectively engaging and moving related ones of the bits. Bit position sensing elements, such as detents are carried by each of the bit positioning means so as to move therewith while a receiving zone adjacent to the path of movement of the detents, is adapted to receive a coding element, such as a flexible card or substrate therein provided with coded portions, such as the openings 36 therethrough unique to a given lock to be operated by the variable key. The openings each receive a detent therethrough to arrest movement of its related bit positioning means thereby arresting the bit positioning means at a position related to the position of the card opening.

In general, key assembly 10 in its unlocked condition is inserted into setting mechanism 32 whereby upon insertion of the coding element, such as the punched hole accounting card 34 prepared with openings 36, (or other coded substrate) the rotation of crank 33 will serve to position each of the bit elements 12 to positions respectively related to the card openings.

Thus, with particular reference to FIG. 3, there has been shown one of a number of bit-setting assemblies 37 in exploded form in the upper right hand portion of the figure while the remaining bit setting assemblies 37 are assembled in the lower left corner of the figure. The operation and construction of each of the bit-setting assemblies is substantially the same and, accordingly, only one such assembly 37 shall be explained herein.

Briefly, in general, each of the assemblies 37 includes means which serves to engage the opposite sides of the bit portion 12a projecting radially outwardly of shank 11 and further serves to move the bit to its coded position. In order to accomplish the last named function, a resilient detent 38 moves about the axis of the key shank 11 conjointly with positioning of the bit 12 associated therewith. Means, such as the punched hole accounting card 34, are arranged to be insertable into the path of detents 38 to arrest them at various positions for positioning the bits 12 associated therewith at their assigned positions with respect to the location of the openings in the punched hole accounting card.

Further, means such as the crank 33 operating through a gear train to be described further below serves to move the detents 38 until they are arrested by penetration of one of the openings 36 in the accounting card 34 so as to halt the further movement of the bit element being positioned at that time.

With the above general understanding a detailed description of the arrangement shown in the upper portion of FIG. 3 can be readily understood.

Briefly, a front face plate 39 carries a pair of Babbitt bearing assemblies 41 recessed into its rear wall and is further formed to include a conically dished face portion 39a which carries, at its central axis, a generally cylindrical key receiver 42 formed with a registration surface 43 serving to register with the flat 25 of collar 26. In addition ball detent 31 is urged upwardly by a spring 44 causing ball detent 31 to engage the dimple 29 formed in flat 25. Simultaneously, upon seating of detent 31 the flat 17a registers with flat 69b.

When ball detent 31 has firmly engaged dimple 29 the key will be properly inserted and registered within the receiver 42 whereby each radially protruding bit portion 12a is flanked circumferentially on opposite sides by positioning surfaces 46, 47 respectively of spiders 48, 49.

In operation, spiders 48, 49 are arranged to be counter-rotated whereby one of the surfaces 46 will contact a bit portion 12a on one side while one of the surfaces 47 will contact the bit portion 12a on its opposite side. Surfaces 46, 47 commence movement simultaneously from mutually retracted positions so that (depending upon the initial radial orientation of any given bit portion 12a) contact with the bit portion 12a can be first made by either surface 46 or 47, i.e. by a setting disk spider 48 or a follower disk spider 49.

As explainable by reference to FIG. 6, if bit portion 12a extends to the left of center surface 46 will strike it first and commence a setting movement of bit element 12 until detent 38 enters one of the openings 36 of card 34 to be engaged by a stop opening 99 formed in lid 93. In the event that surface 47 engages with bit portion 12a before detent 38 finds its opening 36, spider 49 will be reversed by the overpowering action of the rotational forces applied to rotate spider 48 by means as described further below.

Where bit portion 12a extends to the right of center, surface 47 will strike it first and carry the bit leftward (as shown) until mutual engagement is made with the overpowering setting surface 46, or until detent 38 finds its associated opening 36.

Thus, it is readily apparent that bit portions 12a are positively engaged on both sides and in this way a bit will be carried positively and firmly until detent 38, associated with spider 48 finds an opening in card 34, whereupon engagement of detent 38 will arrest further movement of both spiders 48, and 49 when the bit element 12 is mutually engaged therebetween. Subsequently, in order to remove the key assembly 10 from the setting mechanism 32, the key bits are first locked in position by movement of the key bow 19 moved in a direction reverse to that of arrow 23. Crank 33 is then reversely rotated and this serves to retract the contacting surfaces 46, 47 from continuous engagement with the sides of bit portion 12a so that the key assembly 10 can be withdrawn from the mechanism.

Accordingly, a bit setting assembly 37 as shown in FIG. 3 includes a setting disk 51 formed with an axially protruding lip 52 interrupted at five radial positions to provide notches 53 adapted to receive the ends or feet 54 of spider 48.

The central portion of spider 48 is formed to include the keyhole shaped opening 56 to receive bit elements 12 therethrough. Setting disk 51 has been provided with gear teeth 57 for rotating disk 51 as described further below. The outer periphery of disk 51 nests within the inner edge of a body element 58 open at its upper periphery throughout an arc 59 to accommodate circumferential movement of detent 38 between the bounding limits of the upper ends of element 58.

The interrupted annular lip 52 of disk 51 is journaled within the central opening of a thin metallic spacer 61 adapted

to accommodate entry and movement of spider 48 therein while supporting disk 51. Another body element 58' embraces a follower disk 62 in the same manner and is also formed with teeth 63 for rotating disk 62 and its associated spider 49 in an opposite direction to the direction of rotation of spider 48. Spider 49, is similarly carried by disk 62 by means of notches comparable to notches 53 of disk 51 and journaled for rotation by a lip 65 riding within the central opening of another spacer 61'.

Alignment rods 64 extend from the front face plate 39 rearwardly through the alignment openings 66 formed in each of the body elements 58 and spacers 61 and ultimately through alignment openings 67 and 68 respectively formed in a rear body section 69 and rear retaining plate 71. Bolts 70 then can be threaded into holes 80 of face plate 39 to hold the parts together.

Means for counter-rotating the setting disks 51 and follower disks 62 comprises a drive arrangement generally comprising two sets or stacks 72, 73 of counter-rotating friction drive gears whereby the gears of one set engage and drive the setting disks 51 and the gears of the other set engage and drive the follower disks 62. In this manner the positioning surfaces 46, 47 of spiders 48, 49 respectively are counter rotated into position against opposite sides of a bit portion 12a.

The two sets of counter-rotating gear assemblies are shown in the lower portion of FIG. 3 at 72 and 73, with one of the gear assemblies exploded therefrom for purposes of explanation.

Thus each set 72, 73 is supported for rotation by a spindle 74, 75. At the right hand or rear end of each set 72, 73 a main drive gear 76, 77 has been keyed to its respective spindle 74 or 75. Gears 76, 77 are disposed to be in mesh with each other whereby they will produce counter-rotating movement of spindles 74, 75. These gears are driven through a gear train by means of the pinion gear 78 rotated directly by crank 33 and in mesh with a reduction gear 79 formed with a crescent shaped opening 81 cut into one face and into which the tip end of a stop screw 82 (FIG. 5) can enter to limit the degree of rotation which can be applied via crank 33.

Gear 79 meshes with gear 76 in order to drive the set of gears 72, and gear 76 meshes with gear 77 in order to drive the set of gears 73.

Inasmuch as both sets 72, 73 of friction gears are assembled in the same manner only one will be disclosed as shown in FIG. 3. Thus, a spacer washer 83 is formed with a lip 84 for entering the circular opening formed within a wave washer 86 interposed between washer 83 and the flat side of friction gear 87. A shaft nut 88 and a lock nut 89 are both threaded onto the end of spindle 75 and secured in position by tightening nut 89 against nut 88.

The opposite ends of spindles 74, 75 are journaled in bearings 41 and in bushings 91. It is to be understood that the gears 87 in the friction stack comprising the set 72 are offset with respect to the plane of the friction gears 87 in the set of gear 73 so that these two sets of gears 72 73 do not themselves mesh.

Briefly, and as will be more fully explained below, as crank 33 is rotated pinion 78 rotates in the same direction. Gear 79 rotates in an opposite position driving the main drive gear 76 meshed with main drive gear 77. Accordingly the friction gears 87 of each of the two stacks 72, 73 rotate in an opposite direction for respectively moving their associated setting or following disks 51, 62 in mutually opposite directions. Ultimately, however, detent 38 will engage an opening of the inserted accounting card 34 thereby arresting further movement of setting disk 51. In the event that the follower disk has not yet caused its positioning surface 47 of its associated spider 49 to engage the bit portion 12a, follower disk 62 will continue to be driven until such contact is made.

Whenever detent 38 arrests further movement of disk 51, or whenever follower disk 62 is arrested by contact of surface 47 with bit portion 12a and the bit portion 12a is then being held, the friction gears 87 will skid relative to wave washers 86 and

the relative friction between the wave washers of one set 72 and the other set 73 must be such that the friction gears 87 of set 72 will overpower and reverse the rotation of the follower disks 62 and their associated friction gears 87 in set 73.

Briefly, then, it can be stated that notwithstanding prior mutual engagement of opposite surfaces of the bit portion 12a of a given bit element 12 a first friction drive means can serve to reverse the movement of the other friction drive means so as to move the bit positively until arrested by an insertable means such as the accounting card 34 cooperating with a detent 38, the openings 36 of which permit detent 38 to engage one of the registration stops 99.

The perforated substrate or accounting card 34 is insertable into the path of the various detents 38 by providing a slot 92 (FIG. 5) between a pivotally supported lid or cover assembly 93 which is normally locked closed by means of a screw 94. Normally the cover assembly 93 is retained in this manner at a spaced distance from the upper rounded portion of face plate 39 and bit setting assemblies 37 so that the accounting card 34 can be inserted into the left-hand edge of the slot 92 (as shown in FIG. 1). As card 34 is inserted the detents 38 are normally retracted by crank 33 to the position 38' shown in phantom lines in FIG. 6 whereby their tips are disposed beneath an overhanging protective edge margine 40. The inserted leading edge 96 is disposed in registration with the aligned edges 97 of body elements 58, 58', aligned with registration surfaces 97' (of face plate 39), and of 97'' (of rear body section 69). The edge 96a of card 34 is disposed in register with a registration edge 95 (FIG. 5) formed as a shoulder depending from lid 93.

The underneath surface of lid assembly 93 has been formed with a matrix of guide rails 98 serving to smoothly engage the entering edge 96 of card 34. In addition, the matrix formed on the underside of lid assembly 93 includes a rectilinear matrix of stops 99 spaced at intervals corresponding to the spacing between adjacent holes formed in the columns of the accounting card so that each stop 99 represents a given radial bit position of detent 38.

As noted above, the stops 99 further serve to provide the restraining force cooperating with any given detent which has penetrated one of the openings 36 in the accounting card 34.

From the foregoing it will be readily evident that there has been provided an improved system and key for utilizing a single universal key and means for setting the key to cooperate with any one of a number of differently coded locks to be operated. Accordingly, when a route man starts to make his rounds of a number of machines to be serviced the accounting cards can be previously sorted and arranged in a predetermined order to provide the most efficient routing of the service man from one machine to the next so that as each machine is reached the top card of the pile can be utilized to set the bits of the key for operating the lock located at that particular location.

In operation, and referring to FIGS. 4 through 8 it can be seen that the card 34 has been inserted in the setting mechanism 32 as shown in FIG. 6 whereby the friction driven gears of set 73 serve to rotate the follower disks 62 in a counterclockwise direction. The gears of set 72 serve to drive the setting disks 51 in a clockwise direction carrying detent 38 (now in its retracted position due to the pressure of card 34 acting upon the outward tip thereof).

In FIGS. 6, 7 and 8 schematic representations have been provided (eliminating the provision of the spiders 48, 49). Thus, as shown at the central portion in FIGS. 6, 7 and 8 the bit element 12, (being located at a substantially vertically oriented position as shown in the drawing) will be contacted substantially simultaneously by the positioning surfaces 46, 47 respectively of the setting disks 51 and the follower disks 62. This condition is shown in FIG. 7. The opening 36', however, is disposed slightly to the right of the vertical position for bit 12 and accordingly setting disk 51 continues its movement by overpowering the friction resistance in the drive train for follower disk 62 so that, as indicated in FIG. 8 by the reversing arrow 101, disk 62 will be reversed and ultimately detent 38

will engage opening 36' and thereby arrest further rotational movement of bit 12 notwithstanding continued driving of the stacks of friction gears 72, 73.

In the event that opening 36' had been located to the left of the vertical center line in FIGS. 6 through 8 it is apparent that detent 38 would have been arrested prior to the reversal of follower disk 62. In this instance follower disk 62 merely continues to progress counterclockwise until its positioning surface 47 engages the flat side of bit 12 thereby insuring that bit 12 has been positively positioned to a given radial location prior to locking and removing the key from the setting mechanism.

In order to release the key from the setting mechanism it is first desirable to move the bow 19 of lock assembly 10 to the position shown in FIG. 2 whereby all bits will be firmly secured in place. Then crank 33 is reversed so as to reverse both the setting and follower disks 51, 62 respectively. This reverse driving of the setting and follower disk serves merely to retract their respective positioning surfaces 46, 47 thereby making it possible to withdraw key assembly 10 from mechanism 32. It further serves to retract detents 38 to the position 38' (FIG. 6) where they will be clear of the slot 92 (FIG. 5) when a card 34 is to be inserted.

I claim:

1. A system for selectively coding a key to correspond to the code of any one of a plurality of differently coded locks to operate a given one of said locks comprising key means having bits settable variously to a number of coded arrangements thereof, a punched hole accounting card carrying openings therein defining the code for said given one of said locks, and setting means for receiving said card and key and serving to set the key bits in response to openings of the card.

2. A system for selectively coding a key to any one of a plurality of differently coded locks to operate a given one of said locks comprising a key assembly having a plurality of bit elements, each bit element being movable to a plurality of coded positions, and means selectively operable for retaining or releasing said bits in their coded positions, means for receiving said key bits to be moved to their respective coded positions for said one lock, and selectively coded setting means for operating the last named said means and serving to move said bits to their said coded positions whereby the first named means can be operated to retain said bits in their coded positions and the key assembly removed from the setting means in condition adapted to operate said one lock.

3. A system according to claim 2 wherein said setting means includes means for engaging and positioning said bits and further includes movable detent elements associated therewith, said detent elements being adapted to be engaged by openings formed in a substrate, and means for receiving the substrate in a position disposed to cause said detent elements to engage said openings for positioning said bits in accordance with the openings in said substrate.

4. A system for selectively coding a key to correspond to the code of any one of a plurality of differently coded locks to operate a given one of said locks comprising key means having bits settable variously to a number of coded arrangements thereof, coding means having predetermined code portions for defining the code for said given one of said locks, and setting means having means for receiving said one key, said setting means also having sensing portions for sensing said coded portions and serving to set the key bits in response thereto.

5. In a system for selectively setting the bits of a key to correspond to the code of any one of a number of differently coded locks so as to be adapted to be selectively set to operate a given one of said locks, a translating device for setting the bits of a key comprising a plurality of bit-setting assemblies associated respectively with the key bits to be set to coded positions, each said assembly including means serving to engage opposite sides of a bit projecting radially outwardly of a key shank and further serving to dispose the bit to its coded position, the last named means including a detent movable con-

jointly with positioning of said bit, means insertable into the path of said detent to arrest same for positioning the bit in relation thereto, and means for moving the detent to be so arrested thereby setting the bit with respect to the position at which said detent is arrested.

6. In a system for selectively setting the bits of a key according to claim 5 wherein the last named means further comprises first and second counter-moving friction drive means, the drive friction of the first being greater than the second so as to allow the first to overdrive the second, and wherein said means engaging opposite sides of the bit comprises oppositely driven elements each formed with a bit-engaging surface portion, said first and second drive means being respectively coupled to drive respective ones of said oppositely driven elements whereby notwithstanding mutual engagement with opposite surfaces of said bit the first friction drive means serves to reverse the movement of the other so as to move the bit positively until arrested by said insertable means cooperating with said detent.

7. In a key setting mechanism having counterrotating elements with portions respectively engaging opposite sides of a key bit, and one of said elements carrying a detent for cooperation with means insertable into the path of movement of the detent to arrest same, a drive arrangement comprising first and second counter-rotating friction driven gears for respectively engaging and driving first and second ones of the counter-rotating elements to carry their respective said portions into engagement with opposite sides of a key bit common to each, the friction in the drive connection for driving said first gear being greater than for said second gear whereby after both said portions engage a bit common to each, said first gear can overpower the second gear to carry the bit therebetween until arrested by said detent engaging said insertable means.

8. For setting the movable bits of a key to a selected combination of positions thereof a plurality of discrete bit-positioning means, individually operable, for respectively engaging and moving related ones of said bits a setting element carried by each of said bit-positioning means to move therewith, a substrate-receiving zone adjacent the paths of movement of said elements adapted to receive a substrate therein provided with portions at coded positions thereof unique to a given lock to be operated by the key and for engaging an element to arrest movement of its related bit-positioning means thereby arresting the bit-positioning means at a position related to the position of said portion.

9. For use with a system for selectively coding a key to correspond to the code of any one of a plurality of differently coded locks, a universal key assembly for operating a number of differently coded locks comprising at one end an elongated shank or stem, a plurality of bit elements mounted at spaced intervals along the stem and having radially outwardly extending bit portions movable variously through an arc about said shank, and means for selectively locking or releasing said bits in their respective relative arcuate positions.

10. For use with a system for selectively coding a key to correspond to the code of any one of a plurality of differently coded locks, a universal key assembly according to Claim 9 wherein the last named means comprises a bow element at the other end of the key assembly pivotable between advanced and retracted positions about an axis transversely of the axis of said shank, a cam element carried by the bow and serving in one of said positions to frictionally engage and compress said bit elements into compacted relation and in the other position to release said bit elements for movement about said shank.

11. For use with a system for selectively coding a key to correspond to the code of any one of a plurality of differently coded locks, a universal key assembly according to claim 9 further including a movable collar carried by said shank for movement through said arc, and an arcuate ward formed upon said collar and adapted to require alignment of said ward with said bits in order to be releasable from a lock operated by said key.

9

10

12. A system as in claim 4 wherein said coding means includes a coding element having portions to be sensed by said setting means to set the key bits in response thereto.

13. In a system for selectively setting the bits of a key to correspond to the code of any one of a number of differently coded locks so as to be adapted to be selectively set to operate a given one of said locks, a translating device for setting the bits of a key comprising a plurality of bit-setting assemblies associated respectively with the key bits to be set to coded

positions, each said assembly including means serving to engage a bit element carried by a key shank and further serving to dispose the bit to its coded position, the last named means including a portion movable conjointly with positioning of said bit, and coding means for disposing said portion at a predetermined coded position for positioning the bit in relation thereto.

* * * * *

10

15

20

25

30

35

40

45

50

55

60

65

70

75