



US00D577689S

(12) **United States Design Patent**
Yasuoka et al.

(10) **Patent No.:** **US D577,689 S**

(45) **Date of Patent:** **** Sep. 30, 2008**

(54) **LIGHT EMITTING DIODE**

Primary Examiner—Selina Sikder

(74) *Attorney, Agent, or Firm*—Global IP Counselors, LLP

(75) Inventors: **Tsuyoshi Yasuoka**, Anan (JP); **Keiji Funamoto**, Tokushima (JP)

(57) **CLAIM**

(73) Assignee: **Nichia Corporation**, Anan-shi (JP)

The ornamental design for a light emitting diode, as shown and described.

(**) Term: **14 Years**

(21) Appl. No.: **29/273,596**

DESCRIPTION

(22) Filed: **Mar. 9, 2007**

(30) **Foreign Application Priority Data**

| | | | |
|---------------|------|-------|-------------|
| Sep. 15, 2006 | (JP) | | 2006-024861 |
| Sep. 15, 2006 | (JP) | | 2006-024884 |
| Sep. 15, 2006 | (JP) | | 2006-024885 |
| Sep. 15, 2006 | (JP) | | 2006-024886 |
| Sep. 15, 2006 | (JP) | | 2006-024887 |
| Sep. 15, 2006 | (JP) | | 2006-024889 |
| Sep. 15, 2006 | (JP) | | 2006-024890 |
| Sep. 15, 2006 | (JP) | | 2006-024891 |

FIG. 1 is a front side perspective view of a light emitting diode in accordance with a first embodiment of our new design;

FIG. 2 is a rear side perspective view of a light emitting diode in accordance with the first embodiment of our new design;

FIG. 3 is a top plan view of the light emitting diode in accordance with the first embodiment of our new design;

FIG. 4 is a bottom plan view of the light emitting diode in accordance with the first embodiment of our new design;

FIG. 5 is a front elevational view of the light emitting diode in accordance with the first embodiment of our new design;

FIG. 6 is a rear elevational view of the light emitting diode in accordance with the first embodiment of our new design;

FIG. 7 is a right side end elevational view of the light emitting diode in accordance with the first embodiment of our new design;

FIG. 8 is a left side end elevational view of the light emitting diode in accordance with the first embodiment of our new design;

FIG. 9 is a top plan view of the light emitting diode in accordance with the first embodiment of our new design with environment shown in broken lines;

FIG. 10 is a cross sectional view of the light emitting diode in accordance with the first embodiment of our new design as seen along section line 10—10 of FIG. 9;

FIG. 11 is a front side perspective view of a light emitting diode in accordance with a second embodiment of our new design;

FIG. 12 is a rear side perspective view of a light emitting diode in accordance with the second embodiment of our new design;

(51) **LOC (8) Cl.** **13-03**

(52) **U.S. Cl.** **D13/180**

(58) **Field of Classification Search** D13/180;
D26/2; 257/79, 80, 81, 88, 89, 95, 98, 99,
257/100; 313/483, 498, 500; 362/555, 800
See application file for complete search history.

(56) **References Cited**

U.S. PATENT DOCUMENTS

| | | | | | | |
|--------------|----|---|---------|-------------|-------|---------|
| D489,692 | S | * | 5/2004 | Ishida | | D13/180 |
| D495,668 | S | * | 9/2004 | Kim et al. | | D13/180 |
| D500,292 | S | * | 12/2004 | Ishida | | D13/180 |
| D500,294 | S | * | 12/2004 | Ishida | | D13/180 |
| 6,953,952 | B2 | * | 10/2005 | Asakawa | | 257/103 |
| D512,693 | S | * | 12/2005 | Kim et al. | | D13/180 |
| D528,998 | S | * | 9/2006 | Song et al. | | D13/180 |
| 2006/0023451 | A1 | * | 2/2006 | Han et al. | | 362/249 |
| 2006/0284203 | A1 | * | 12/2006 | Han et al. | | 257/98 |
| 2007/0029564 | A1 | * | 2/2007 | Han et al. | | 257/98 |

* cited by examiner

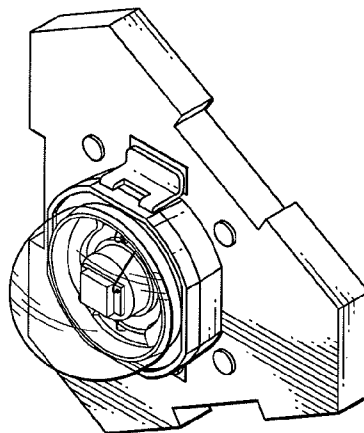

FIG. 13 is a top plan view of the light emitting diode in accordance with the second embodiment of our new design;

FIG. 14 is a bottom plan view of the light emitting diode in accordance with the second embodiment of our new design;

FIG. 15 is a front elevational view of the light emitting diode in accordance with the second embodiment of our new design;

FIG. 16 is a rear elevational view of the light emitting diode in accordance with the second embodiment of our new design;

FIG. 17 is a right side end elevational view of the light emitting diode in accordance with the second embodiment of our new design;

FIG. 18 is a left side end elevational view of the light emitting diode in accordance with the second embodiment of our new design;

FIG. 19 is a top plan view of the light emitting diode in accordance with the second embodiment of our new design with environment shown in broken lines; and,

FIG. 20 is a cross sectional view of the light emitting diode in accordance with the second embodiment of our new design as seen along section line 20—20 of FIG. 19.

The broken line showing of environment (the remaining structure of the light emitting diode) in the FIGS. 9 and 19 is for illustrative purposes only and forms no part of the claimed design.

The opaque line shading illustrates a translucent portion or a transparent portion of the light emitting diode. More specifically, in the first and second embodiments, the coating material that covers the light emitting diode chip is preferably translucent, and the lens is preferably transparent.

The cross sectional views illustrated in FIGS. 10 and 20 are presented solely for the purpose of clarifying the shape of exterior surface of the claimed design.

1 Claim, 6 Drawing Sheets

FIG. 1

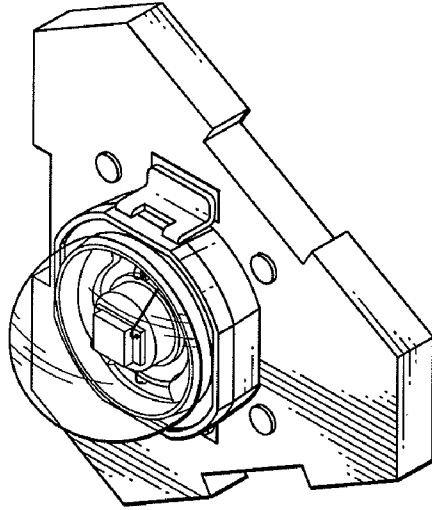

FIG. 2

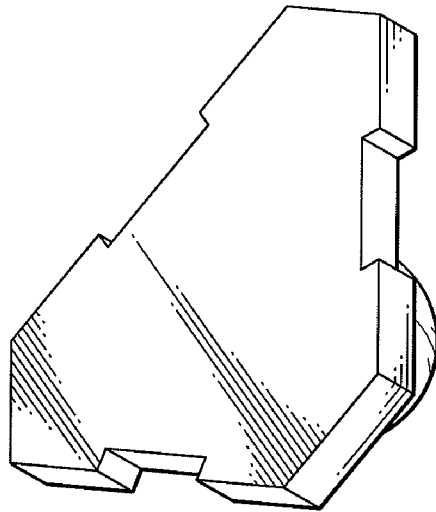

FIG. 3

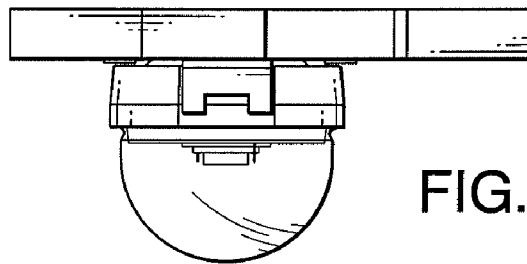

FIG. 4

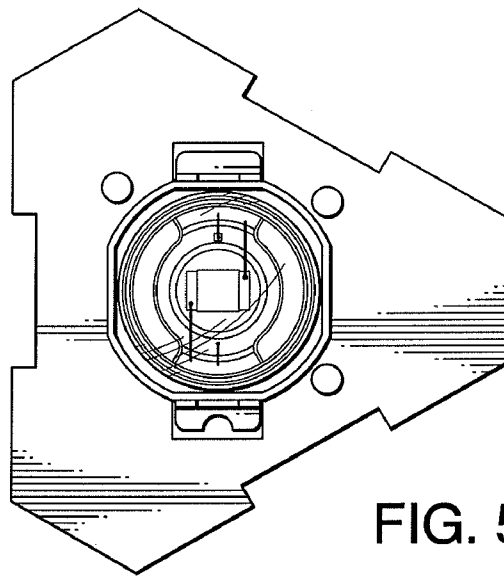
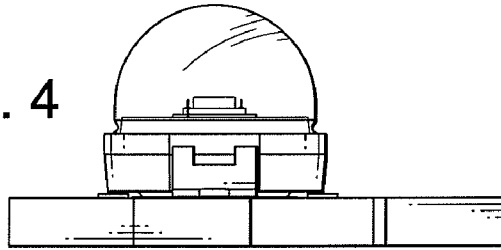

FIG. 5

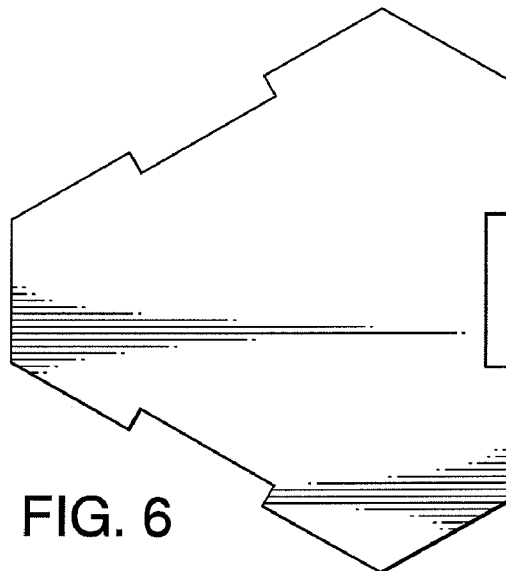

FIG. 6

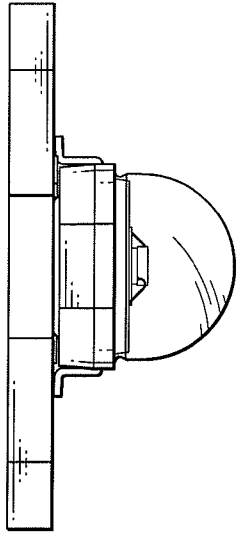

FIG. 7

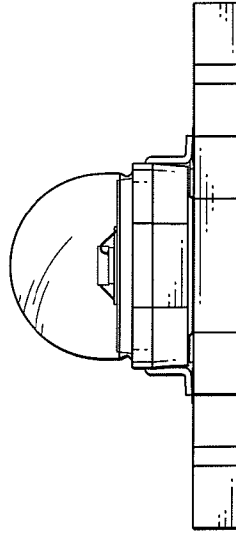

FIG. 8

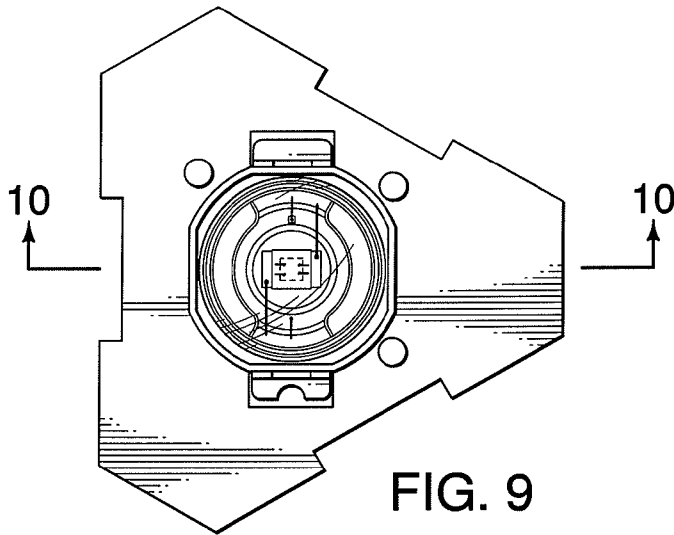

FIG. 9

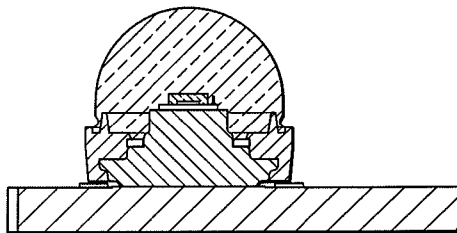

FIG. 10

FIG. 11

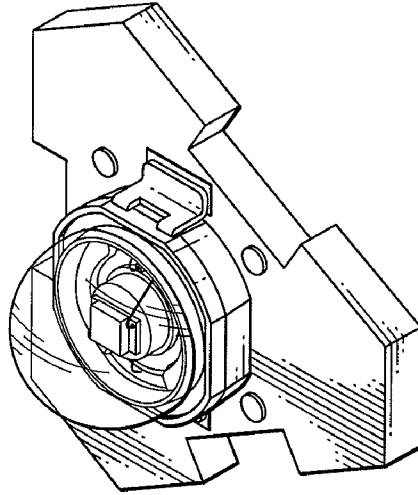

FIG. 12

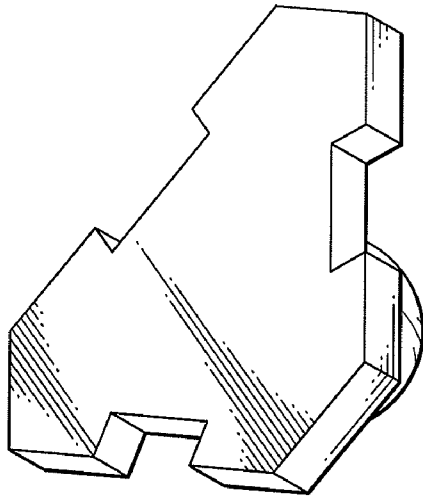

FIG. 13

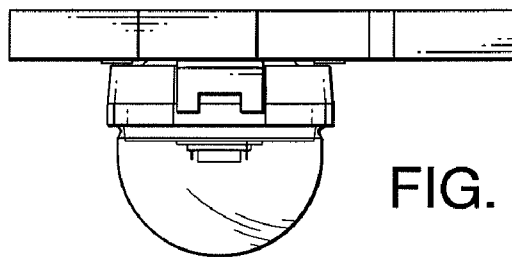

FIG. 14

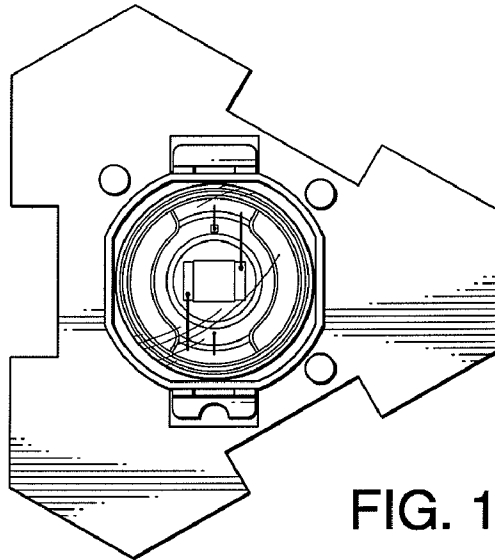
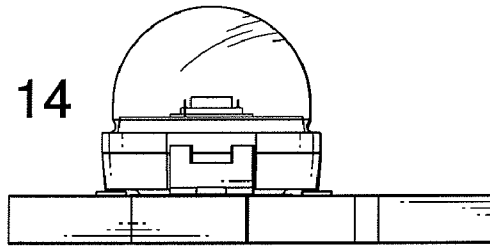

FIG. 15

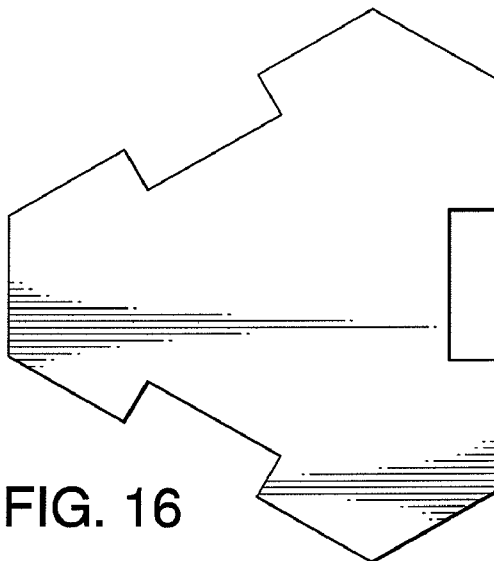

FIG. 16

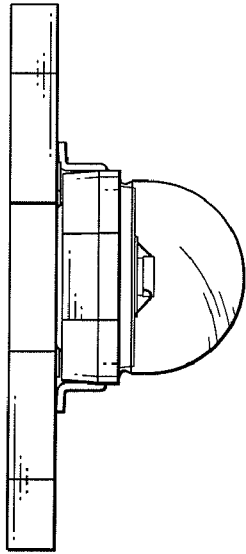

FIG. 17

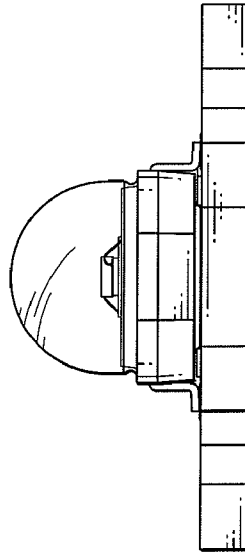

FIG. 18

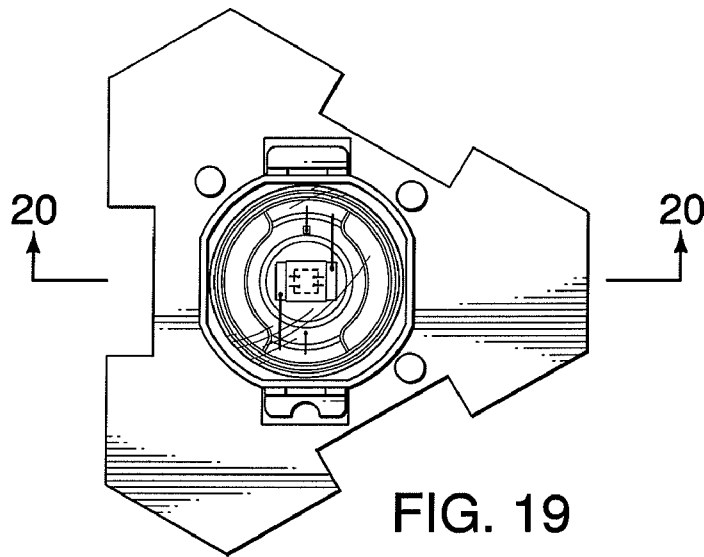

FIG. 19

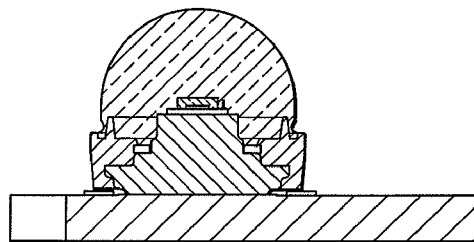

FIG. 20