



AFRICAN REGIONAL INDUSTRIAL PROPERTY ORGANISATION (ARIPO)

940

(11)

(A)

<p>(21) Application Number: AP/P/98/01363</p> <p>(22) Filing Date: 19970306</p> <p>(24) Date of Grant & 20010212</p> <p>(45) Publication</p>	<p>(73) Applicant(s): DYNAMIC TELECOMMUNICATIONS, INC. 12850 Middlebrook Road #302 Germantown MD 20874 United States Of America</p>
<p>(30) Priority Data</p> <p>(33) Country: US</p> <p>(31) Number: 08/618,581</p> <p>(32) Date: 19960320</p>	<p>(72) Inventors: Jelena VUCETIC 12850 Middlebrook Road #302 Germantown MD 20874 United States Of America (See Overleaf)</p>
<p>(84) Designated States:</p> <p style="padding-left: 20px;">GH KE LS MW SD SZ</p> <p style="padding-left: 20px;">UG</p>	<p>(74) Representative FISHER CORMACK & BOTHA P O BOX 74 BLANTYRE MALAWI</p>

(51) **International Patent Classification (Int.Cl.7):** H04Q 7/20

(54) **Title:** Fixed Wireless Terminals In Network Management Method And Apparatus

(57) **Abstract:**

A network management method and apparatus for wireless terminals. The method and apparatus comprises a new generation of wireless terminals having digital signal processors that can monitor the operating characteristics of the associated wireless terminals and report those characteristics to a network management computer. The network management computer receives communications from the wireless terminals and takes corrective action for out-of-specification conditions and updates the associated DSPs with corrections and flexible dialing instructions. The network management computer also gathers utilization statistics reported to it by the wireless terminals. The wireless terminals can be initialized by direct connection to the wireless terminal with a simple telephone instrument or can be initialized over the air by the network management computer.

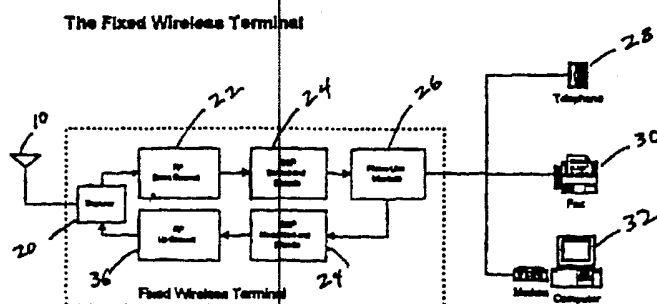

Inventors Continued

Paul KLINE
11608 Drumcastle Terrace
Germantown
MD 20876
United States of America

TITLE: FIXED WIRELESS TERMINALS IN NETWORK MANAGEMENT METHOD AND APPARATUS

1 Background of the Invention:

2 This invention relates generally to wireless telecommunications and more particularly
3 to a method and apparatus for wireless terminals and network management associated with
4 wireless network comprising such wireless terminals.

5 Background:

6 The telephone has clearly been one of the major technological leaps over the last one
7 hundred years or so. Traditionally telephone networks have relied upon millions of miles of
8 wire strung between points to effect such communications. Improvements in such "wired"
9 communication have been fiber optic links and other wideband slinks that rely upon the
10 physical connection between points.

11 Despite this technological marvel, the telephone has not reached many parts of the
12 world where large distances would require stringing many more miles of wire to serve
13 locations which might prove to be of dubious commercial value. In short, in many rural
14 areas of the United States and in many third world countries telecommunications over wire
15 links have failed to develop or have developed slowly at best.

16 Satellite communications have allowed telecommunications to be extended to many
17 parts of the world. However, such telecommunications still rely upon local wired networks of
18 one form or another to allow communications via satellite to reach the individual homes or
19 community once the down link to a ground station has been made. Again, there can be
20 substantial burdens in both geography and finances to allowing such telecommunications to
21 take place.

22 The world of wireless telecommunications offers tremendous advantages over the
23 stringing of miles of wire through inhospitable countryside. With such wireless

AP/P/98/01363

1 telecommunications a radio link is needed in order for communications to be established from
2 one point to another. Further, the cost of such terminals has been decreasing dramatically
3 over the years such that many countries are now taking a technological "leap frog" approach
4 to establishment of a telephone communication infrastructure by simply moving directly to
5 wireless networks without even worrying about installing wires.

6 A further factor driving the world toward wireless telecommunications is the fact that
7 with wired communications, in the event of an interruption in the communication services, a
8 service vehicle must be sent to inspect literally the entire communications path over miles of
9 wires in the event that the problem can not be traced directly to the subscriber's or the
10 telephone operator's equipment. Having such a work force and service fleet "on call" is an
11 expensive venture and results in very large maintenance costs associated with maintaining
12 high quality communications over wire links. Further, the maintenance of wired
13 communication links is an expensive prospect requiring various types of wires or fiber optics
14 as well as the physical facilities for maintaining these wires either on poles or buried in
15 conduits throughout the countryside.

16 Wireless telecommunications is clearly an attractive solution for telecommunications
17 in rural and remote areas as well as in areas with underdeveloped or no telephone
18 infrastructure whatsoever. Wireless telecommunication also offers significant savings in
19 maintaining the telecommunications infrastructure since only base stations and signal
20 repeating stations if necessary must be maintained as opposed to many hundreds or thousands
21 of miles of wire. An additional advantage of wireless telecommunications is that there is
22 a significant cost savings of installing the infrastructure since wires no longer need to be
23 installed throughout the country side.

24 There still exists however a difficulty in maintaining particular telecommunications

1 networks as they now exist, even in wireless form. At the present time, in order to access a
2 problem with a wireless terminal, whether it be a cellular telephone or other type of wireless
3 communication, equipment must be brought into a maintenance depot for diagnostics and
4 analysis. In the alternative, a service person must be sent to the location of the wireless
5 equipment in order to access the difficulty. Remote diagnostics, which exist in various
6 network elements do not yet exist for such wireless telecommunications terminals.

7 Wireless systems have been the subject of much invention. Patent No. 5,121,391 to
8 Paneth et al. was granted for a "Subscriber RF Telephone System for Providing Multiple
9 Speech and/or Data Signals Simultaneously Over Either a Single or Plurality of RF
10 Channels." This invention recognizes the need for a plurality of signals being received and
11 simultaneously transmitted over RF channels. While this invention clearly notes the need for
12 a network of remote terminals, the issue of how to monitor the health of the subscribers'
13 terminals on the network is not discussed. The invention only deals with the subscriber
14 stations having means to receive and transmit channel signals.

15 Patent No. 5,295,178 to Nickel et al. was granted for a "Digital Signal Processor for
16 Radio Base Station." This particular invention deals with a DSP in a base station that
17 communicates information to a central control board. The key emphasis of this invention is
18 dealing with a tone control squelching coder for the control of a processor. It does not deal
19 with issues relating to network management or monitoring the health of subscriber terminals
20 in an automated fashion.

21 Patent No. 4,890,315 to Bendixen et al. was granted for a "Cellular Remote Station
22 with Multiple Coupled Units." This invention does describe a network system for coupling a
23 plurality of telephones to a remote land line telephone system including interfaces. This
24 system deals with cellular "remote cellular "station" communicating with subscriber terminals

AP/P/ 98 / 01363

1 but also being able to communicate with the public switching telephone network. In essence
2 the invention allows normal telephone systems to be used with a cellular telephone
3 transceiver. No provision is made for monitoring the health of a network or for ease of
4 programming any special equipment.

5 Patent No. 4,469,494 to Ortez Perez et al. was granted for a "Self Diagnostic System
6 For Cellular Transceiver Systems." This invention deals with self diagnostics in a cellular
7 system which checks some of the functions of a cellular transceiver system and which, in
8 turn, couples a standard telephone to a cellular transceiver. This invention begins to deal with
9 the issue of monitoring the health of an individual subscriber terminal locally but does not
10 provide network-wide maintenance nor management functionality.

11 Patent No. 5,031,204 to McKernan was granted for an "Interactive Diagnostic System
12 for Cellular Telephones." This invention allows monitoring of the health of an individual
13 cellular telephone unit from that specific cellular telephone unit upon initialization by the
14 sales agent. Again, the ability to monitor the network of subscribers of remote telephone
15 units is not dealt with in a centralized fashion nor is the ability to monitor the entire network
16 centrally provided.

17 General Description of the Preferred Embodiment:

18 It is therefore an objective of the present invention to have wireless terminals WTs
19 either fixed or mobile that can be initialized, managed, and maintained remotely with
20 significantly reduced need for a service technician physically handling the wireless
21 telecommunications equipment.

22 It is a further objective of the present invention to create a network of wireless
23 terminals which is easy to maintain and diagnose in the event that problems exist in the
24 equipment or communications link.

1 It is a further objective of the present invention to decrease the cost of test equipment
2 necessary to diagnose problems with wireless telecommunications equipment.

3 It is a further objective of the present invention to decrease the number of
4 unsuccessful over-the-air initializations of wireless equipment by providing simple directly
5 connected initialization procedures.

6 It is a further objective of the present invention to provide a secure initialization
7 process via local initialization of wireless telecommunications equipment, rather than over the
8 air.

9 It is a further objective of the present invention to create a user friendly initialization
10 procedure with audible feedback in the event of errors in initialization.

11 Wireless terminals WTs are devices that are deployed at a subscriber's site to provide
12 a wireless connection between a subscriber's telephone and the network infrastructure or may
13 be mobile and transportable. It is difficult to install operational parameters in the WT during
14 the production process since the operating environment may not be known in advance. Since
15 these parameters depend upon the overall system and infrastructure in which the WT will be
16 operating as well as the services that any given subscriber will be paying for, these parameters
17 must be programmed at the time of installation. The only parameter which is generally
18 factory set is a serial number which is isolated from tampering.

19 When a new WT is installed in a network, it contains a serial number as a predefined
20 operational parameter. All of the parameters of operation are set during the initialization
21 procedure. Traditionally, operational parameters are set in one of the following ways:

- 22 1. A new subscriber configures the WT at the place of purchase using an
23 expensive external computer system. After that the subscriber or technician
24 installs the WT on the subscriber's premises.

1 2. An WT is installed on the subscriber's premises and the telephone company
2 sets the operational parameters in the new WT over the air using a temporary
3 directory telephone number that is assigned to the WT at the factory. This
4 number is used only for initialization purposes and is valid until the telephone
5 company sets the operational directory telephone number equivalent to the
6 mobile identification number MIN in a mobile wireless network in the new
7 WT. This type of over the air initialization occurs without the benefit of any
8 security procedures and is therefore susceptible to monitoring and/or problems
9 in transmission over the air.

10 In both cases initialization of the WT requires special purpose equipment and fairly
11 complicated procedures which can only be accomplished by trained technicians having
12 expensive equipment.

13 The present invention comprises both a network management system for installing,
14 initializing, and managing WTs, and the WTs themselves which represent a new generation
15 of efficient wireless terminals. The WT is first described, followed by the architecture that
16 supports their use.

17 Brief Description of the Drawings

18 Figure 1 is the wireless terminal (WT) architecture

19 Figure 2 is wireless terminal architecture detail

20 Figure 3 is the wireless terminal call control

21 Figure 4 is initialization process of the wireless terminal

22 Figure 5 is initialization process of the wireless terminal (alternate)

23 Figure 6 is network management system architecture

24 Figure 7 is OAMPC architecture

- 1 Figure 8 is WLL network management system hierarchy
- 2 Figure 9 is maintenance procedure for the wireless terminal
- 3 Figure 10 is maintenance procedure for the wireless terminal (alternate)

4 Detailed Description of the Preferred Embodiment

5 Referring to Figure 1, the wireless terminal architecture is shown. As previously
6 stated the present invention anticipates that the WTS may be either fixed or mobile. The WT
7 of the present invention comprises an antenna 10 which is connected to a radio frequency RF
8 front end 12. For purposes of this specification, the term "signals" and "communication" are
9 used interchangeably. Signals from the RF front end 12 are sent to a digital signal processor
10 DSP and controller 14. The DSP and controller 14 are of the type manufactured by Texas
11 Instruments Model No. TMS320C50 which comprises memory and ability to process and
12 receive commands from a remote source. The DSP and controller 14 is connected to a
13 telephone line interface 16 which converts signals from the DSP to available signals suitable
14 for use with normal telephone equipment. The telephone interface comprises an RJ11
15 standard telephone jack and a terminal block to which the subscriber's telephone 18 is
16 connected. This allows any standard DTMF or pulse telephone to communicate via the
17 DSP 14.

18 Referring to Figure 2, the wireless terminal is shown in more detail. The antenna 10
19 is connected to a duplexer 20 whose function is to receive incoming signals from the antenna
20 10 as well as to present outgoing signals to the antenna 10 when a telephone call from the
21 terminals is in progress. The duplexer 20 presents the received RF signal to a front end down
22 converter. The down converter 22 converts the radio frequency band to a lower intermediate
23 frequency IF. This IF is digitized and the digital signal is then sent to the digital signal
24 processor DSP 24. The DSP demodulates the data and, during one time interval, handles the

AP/P/ 98 / 01363

1 base station to terminal protocol. During another time interval, it formats the voice data into
2 standard phone quality speech which is passed to a telephone line interface 26.- The
3 telephone line interface can then have a telephone 28, a fax 30, or a computer 32 hooked up
4 to it via a standard RJ11 phone jack or terminal block.

5 On the transmit side, voice from the phone line is digitized and passed to the same
6 DSP 24. The DSP 24 handles the base station to terminal protocol in one cycle, and
7 modulates the voice data for transmission in another time interval. The base band modulated
8 voice data is then sent in quadrature form I&Q data to the radio frequency up convert block
9 36. The signal is then passed to the duplexer 20 which provides the ability to use the same
10 antenna for transmit and receive simultaneously full duplex. Thereafter, it is sent via RF to
11 either the network in the normal case or the network management system when under remote
12 management which is explained in more detail below.

13 The network management system center or OAMPC (also referred to as the "network
14 management computer") cooperates with the capabilities of the WT to form the network
15 management system of the present invention. The DSP in the WT supports various protocols
16 to the network management center such as a CCITT V.22 type. This link operates in the same
17 manner as a traditional modem over a cellular network. This scheme allows a WT to support
18 network management system features with any vendor's base station. The following
19 functions are supported by the WT's network management interface.

- 20 1. The WT can be entirely reprogrammed to support additional or different
21 features, air interfaces, services and flexible dialing rules. The WT has flash
22 memory on board to support remote uploads with a protective kernel.
- 23 2. As will be explained further below, the network management system center
24 can log onto the WT and perform many tests such as bit error rate BER tests,

1 voice loop back tests, and other built in tests as well as gather utilization,
2 performance; and other statistics.

- 3 3. The WT generates alarms by contacting the network management system
4 center under certain irregular or out-of-specification conditions.
- 5 4. The DSP reduces the circuitry needed for much of the phone line interface
6 circuitry since all tone generation dial tone, busy, reorder, etc., dual tone multi-
7 frequency DTMF detection, pulse dialing detection and call process control is
8 handled in the software of the DSP. In addition, the DSP can support voice
9 activated commands, voice encryption, voice synthesis and analysis and
10 remotely programmable flexible dialing rules.

11 An additional functionality of the DSP is to accept modifications to dialing rules that
12 occur due to changes in the network. For example, currently land line switches detect the
13 "end of dialing sequence" using a set of defined dialing rules residing in the switch. For
14 example, if a user dials "911" a switch immediately detects an end of dialing sequence upon
15 the reception of the second "1" digit. However, periodically dialing rules change and
16 therefore must be modified. The present invention simulates a land line switch by
17 maintaining a local copy of the dial rule database. When changes are made in the network,
18 the new dialing rule data base is remotely uploaded from the OAMPC to the data storage
19 capability of the WT. Thus each WT contains its own dialing rule data base. Without this
20 functionality of the remote network management, flexible dialing rules would not be possible
21 in a wireless telecommunications system. Types of dialing rules that may be created are:
22 autodial options that enable the WT to immediately dial a number when an off hook condition
23 is sensed, sending of a signal to an operator when an interdigit time out interval of a particular

AP/P/ 98 / 0 1 3 6 3

1 duration is sensed as well as other dialing rules allowing the recognition of long distance
2 numbers, the interposing of telephone credit card accounts, and other flexible functions
3 associated with dialing.

4 Since the DSP handles functions in alternating time intervals, it services the phone
5 line control functions during one time interval or is in the conversation mode during a second
6 time interval i.e. communicating with a base station. Thus, the computing power required by
7 the DSP is greatly reduced since it does not simultaneously handle all types of events.

8 Referring to Figure 3, the flow diagram of the WT call control is described. Thus there
9 are four main control modes that the DSP must perform: the idle state waiting for an event,
10 call origination, paging and call-in-progress. The WT begins in an idle state awaiting an off-
11 hook interrupt. When an off-hook interrupt is detected, the dial tone generation function is
12 turned on 42. The DSP then checks to determine if dialing is detected 44. This dial detection
13 is maintained until such time as that dialing is detected or a timer expires. When dialing is
14 detected, the dial tone generation is turned off 46. The DSP then receives the dialing
15 information from either pulse or tone and decodes the dialing and applies the dialing rules
16 associated with the dialing function 48. The DSP detects and then checks to determine if the
17 dialing has been appropriately accomplished 50. If the dialing is determined to be
18 appropriate, the DSP sends the dialed number to the base station 52 and a voice channel
19 assignment is made 54. In the event that the dialing is not valid for some reason, the DSP
20 waits for the condition to be reordered 56 and a reorder tone is generated. The DSP waits in
21 the reorder condition until an off-hook condition persists 58. If the user then hangs the phone
22 up, an on-hook condition is presented and the system returns to the idle status 40.

1 After assignment of the voice channel 54, the DSP constantly monitors the voice
2 channel to determine if the call is still in progress 60. The DSP awaits the situation where the
3 call is terminated 62. If the call is not terminated, the DSP determines that the call is still in
4 progress 60 and the voice channel assignment is maintained. When the call is terminated, the
5 voice channel is released 64 and the overall system is returned to the idle state 40.

6 The WT receives calls by responding to a page command 66 from the base station.
7 Upon responding to the page command, voice channel is assigned 68 and an alert is received
8 from base station 70. Thereafter, a ring is sent to the phone line 72 and the DSP awaits the
9 situation where the telephone is off-hook 74. Once an off-hook condition is received, the
10 DSP monitors the call in progress 60, waits for the call to be terminated 62, releases the voice
11 channel 64 and returns the WT to the idle state 40.

12 While the main control tasks are shown, it should be noted that the DSP does not need
13 to perform all tasks simultaneously and thus is capable of other functions as well such as
14 voice detection and recognition.

15 Referring to Figure 4, the initialization process of the WT is shown. This process may
16 be conducted locally, that is, the site of the WT. Initially, the telephone is placed in an off-
17 hook condition 202. The DSP then determines whether the off-hook condition does in fact
18 exist. If it exists, the DSP determines if a valid password is dialed via keypad of standard
19 phone 203. If an invalid password or error in password is entered, the DSP returns the
20 initialization process to the beginning. If a valid password has been entered it determines if
21 the last parameter was entered. If a last parameter has not in fact been entered, the DSP
22 generates a beep tone 206 prompting the user to enter a specific parameter. The DSP then
23 determines if a parameter has in fact been entered 208. If a parameter has not been entered,

AP/P/98/01363

1 the DSP monitors a specific time period 10 and unless a specific time out has elapsed, the
2 DSP remains in the condition to receive parameters. If a time out has in fact expired, the DSP
3 generates a busy tone 212 thereby prompting the user to place the telephone on-hook 214. If
4 the telephone is on-hook after a time-out condition, the DSP deletes all initialized parameters
5 and returns to the waiting state.

6 If a WT parameter has been entered, the DSP determines if the parameter entered is
7 correct 230. If the parameter is correct, the DSP stores the appropriate parameter 228 and
8 awaits the next parameter 226.

9 In the event that the parameter is not correct, the DSP generates a busy tone, and
10 returns to a state where it is awaiting parameter entry 204.

11 If a last parameter is entered 204, the WT sends the initialized values of parameters to
12 the telephone company for verification 218. If the verification is successful 220, the DSP
13 generates a dial tone 222, the initialization process is ended 224 and the WT is ready to make
14 and receive phone calls.

15 In the event that the verification 220 is not successful, the DSP generates a busy tone
16 212 prompting the user to place the telephone back on-hook and to begin the initialization
process again.

17 An alternative initialization procedure Figure 5 is also provided. This initialization
18 procedure is identical except for the fact that the DSP has the capability of generating a voice
19 message at various locations within the initialization procedure. For example, in the event
20 that a last parameter has not been entered, the DSP generates an "enter parameter number"
21 message 240. This is a more precise indication of the parameter to be entered. In addition,
22 the DSP can generate a specific error message 242 which more specifically designates the
23

AP/P/98/01363

1 error that has been made. The DSP can also generate an "error parameter number" message
2 **244** which also identifies very specifically the error committed as opposed to simply
3 providing a beep tone as in the previous initialization procedure.

4 Referring to Figure 6 the architecture for the network management system for the
5 wireless local loop is shown. The wireless local loop WLL operation administration
6 provisioning and maintenance center OAMPC also referred to as the network management
7 computer performs network management functions for the entire WLL system. The OAMPC
8 **80** communicates through the public switch telephone network PSTN **82** with a mobile
9 switching center MSC **96**. The MSC **96** provides switching between WTs and the PSTN via
10 base stations BS **98**. Communications between WTs **100, 102, 104, 106** and the base station
11 **98** is performed via radio channels using interfaces such as AMPS, NAMPS, TDMA, TACS,
12 ETACS, CTACS, NMT-450, NMT-900, IS-136, GSM, or CDMA. The overall system
13 management can also comprise of wireline switches **84** which provide switching between
14 WTs and the PSTN via a wireless channel bank WCB **86**.

15 Signaling between the WLL OAMPC and the WT may use a standard or proprietary
16 protocol. This may be achieved by inband over the usual voice path FSK tones using a
17 protocol such as CCITT V.22.

18 Referring to Figure 7, to WLL OAMPC architecture is shown. The WLL OAMPC
19 comprises a network element interface WLL NEI **116**, a management information base WLL
20 MIB **110**, network management applications WLL NMA **114**, and a graphical user interface
21 WLL GUI **112**.

22 The WLL NEI **116** performs communications between the WLL OAMPC **80** and all
23 network elements that are on the WLL system. The WLL MIB **110** is a relational database
24 which comprises information on the WLL system which information is relevant to network
25 management. For example, the WLL MIB **110** comprises rules for responding to problems

AP/P/98/01303

1 encountered on the network. If a particular out-of-specification condition is communicated to
2 the OAMPC by a WT, the OAMPC can automatically respond with instruction to correct the
3 particular out-of-spec condition. The WLL NMA 114 includes all functions relevant to the
4 management of the WLL system. The WLL GUI is an based interface between the operator
5 and the WLO AMPC. The WLL NEI 116 also handles all interaction with the public switch
6 telephone network 82.

7 There are two types of messages which are exchanged between the WLL OAMPC and
8 the various network elements: 1 Event driven e.g. generated by a network element upon a
9 failure which are immediately sent to the WLL OAMPC, and 2 polling exchanges wherein the
10 WLL OAMPC sends requests for different information to a network element and the network
11 element responds with the requested information such as performance and utilization
12 characteristics.

13 In, addition, the OAMPC can receive periodic reports from network elements such as
14 WTs on the health of the WTs. These are accomplished on a preset reporting schedule where
15 each WT has a specific time to report its operational characteristics to the OAMPC.

16 The operator at the WLL OAMPC can perform both manual and automatic testing of
17 the network. In manual testing, the operator logs onto an WT and performs tests or retrieves
18 data concerning that WT. In the automatic test mode the operator sets up a schedule for the
19 OAMPC to log on to one or more WTs and thereafter the OAMPC automatically performs
20 tests or gathers data on the WTs being tested.

21 There are several methods which can be used for communications between the WLL
22 OAMPC and WTs. First each WT is assigned a dedicated test identification number TIN. In
23 the test mode, the WLL OAMPC dials the TIN of each WT to log onto the WT in order to
24 initialize testing and retrieve information concerning the health of the WT without ringing the

AP/P/98/01363

1 associated telephone. Second, a group test identifier GTI is assigned. In this test mode the
2 WLL OAMPC dials in at broadcast mode the GTI to all WTs. Each WT in the group has its
3 own timer set to a different time interval unique for each WT. Each WT will respond to the
4 WLL OAMPC when its timer expires. A lack of response from a WT indicates that there has
5 been a communications problem related to the WT. Third, as noted above, each WT has a
6 specific reporting schedule. In this mode the WT initiates a call to the WLL OAMPC at a
7 predetermined time. The WT automatically performs tests such as an audio loop back test,
8 BIT, and a BER test. The WLL OAMPC then collects the test results from all WTs according
9 to the schedule, automatically checking these results for any performance problems and stores
10 the result for further analysis or, communicated a corrective action to the ailing WT based on
11 stored response rules in the OAMPC. If the WLL OAMPC does not receive the report from
12 an WT at a predetermined time, it is an indication that there has been a communications
13 problem related to the WT.

14 Referring to Figure 8, the hierarchy in the WLL network management system (NMS)
15 is described. The WLL NMS has information divided into three categories: information on
16 regions of operations, information on network elements and subscribers, and information on
17 operations and maintenance personnel. Each information category is hierarchically organized
18 and information in all categories are interconnected through various relationships as shown in
19 Figure 6. For regional operations, the WLL network system may be divided into areas. Each
20 area consists of several offices.

21 Each WLL network consists of some or all of the following wireline switches 300,
22 MSCs 302, WCBs 304, BSS 306, and WTs 308. Each area 310 contains one or more BSs
23 and/or WCBs, and WTs connected to them. Each office 312 contains several WTs.

24 A WLL network is operated and maintained by the personnel that includes a superuser

AP/P/ 98 / 0 1 3 6 3

1 320, supervisors 322, operators 324, and technicians. The superuser is primarily responsible
2 for the MSCs and wireline switches in the WLL system. In addition, the superuser may also
3 monitor status and performance and modify parameters of the lower level network elements.
4 The superuser has the highest authority and all access rights to the WLL MIB information.
5 The superuser also oversees all supervisors, operators, and technicians. The second level of
6 personnel hierarchy are supervisors. Each supervisor controls a set of BSs and WCBs in the
7 area that is assigned to the supervisor. In addition, a supervisor may also control the WTs
8 that are connected to the assigned BSs and WCBs. Each area may have one or more
9 supervisors assigned. Each supervisor has a group of operators and technicians reporting to
10 him or her. All supervisors report to the superuser. The lowest level of personnel hierarchy
11 are operators. Each operator is responsible for a subset of WTs, usually in a contiguous
12 geographic area. Each office may have one or more operators assigned. Each supervisor has
13 one or more operators reporting to him or her.

14 Technicians support the network management staff by repairing the failure, in network
15 elements, and installing, upgrading or replacing the network elements. Each technician is
16 responsible for a specified type and subset of NEs. The technicians provide service for the
17 assigned NEs with respect to "trouble tickets" issued by the authorized NM staff.

18 The WLL network management applications NMAs are performed by the WLL
19 network management personnel. The applications are also hierarchally organized. There are
20 three levels of the hierarchy. Each one of them includes a subset of network management
21 applications. Only the superuser may perform all of the defined applications. Each
22 supervisor may perform only the applications related to the information on his or her
23 subordinates, that is, operators and technicians, as well as the network elements that are
24 within his or her responsibility. Each operator may perform only the application related to the

1 network elements that he or she is responsible for.

2 The WLL network management applications include all five OSI standard categories,
3 as follows: performance management, fault management, configuration management,
4 accounting management, and security management.

5 The wireless local loop graphical user interface WLL GUI is the user interface
6 between the WLL OAMPC and the personnel who manage the WLL system. The WLL GUI
7 is also hierarchically organized. For each level of the staff hierarchy there is a separate GUI
8 providing the access to the corresponding scope of the network management applications
9 available to that particular staff level. The WLL network management system is protected
with password mechanism. Upon power up or reset, the WLL GUI requests from the user the
11 user's identifier and password. When the user enters this information, the WLL GUI checks
12 to see if the user is a valid user. If the check-up is positive, the WLL GUI determines the
13 access rights of the user i.e. whether a superuser, supervisor or operator and opens the
14 corresponding GUI. If the check-up of the user identification and password is negative the
15 WLL GUI will not allow access to the WLL OAMPC and sends a warning message to the
16 user.

17 Referring to Figure 9, the maintenance procedure for the WT is described. The DSP
first determines if the phone is off-hook 250. If the phone is off-hook then the DSP
19 determines if a test sequence password has been dialed 252. If the test sequence password is
20 not detected, the DSP determines that a normal telephone call is being placed and the call is
21 processed 266. If a test sequence password is being detected, the DSP generates a beep
22 tone 254 acknowledging that a test is in progress. Thereafter, the DSP determines the number
23 identification of the test being conducted 256. If a test number is not determined, a timeout
24 period begins and so long as the time out period is not expired, the DSP will remain in an

AP/P/98 / 01363

1 alert state ready for its instructions. In the event that the time out period has expired, the DSP
2 generates a busy tone 260 and waits for the phone to be placed in an on-hook condition 262.
3 Once the phone is placed in a on-hook condition, the maintenance procedure is ended. When
4 an appropriate test number is entered 256 the DSP determines if this is a valid test number
5 280. If the test number is not a valid number, the DSP generates a busy tone 278 and returns
6 to a waiting state where the DSP is waiting for an appropriate test number to be entered. If
7 the test number is correct, the DSP determines if the test number is the end of the test
8 procedure 276. If the test procedure is in fact ended, the DSP generates a dial tone and
9 returns to the operating mode 272.

10 In the event that the test number is not the end of the test procedure, the DSP executes
11 the specified test 274 and determines if the test has been passed 270. If the test has not
12 passed, the DSP generates a busy tone 268 and returns to the waiting state, waiting for an
13 appropriate test number to be dialed. If the test is passed 270, the DSP waits for an
14 appropriate additional test number to be entered. In the event that the maintenance procedure
15 is over, the time out will expire 258 and ultimately return the DSP to the end of the
16 maintenance procedure 264 and back to a waiting state to process telephone calls.

17 Referring to Figure 10, an alternative maintenance procedure is described. Again
18 utilizing the capability of the WT to generate voice messages, at specific locations within the
19 maintenance procedure, the DSP can generate an "enter test number" message 282, an error
20 message 284, a test "passed" message 286, additional error messages 290, and WT failure
21 messages 288 which therefore prompt the user more specifically to the problem encountered.

22 Summary

23 The wireless local loop architecture comprising both a specific architecture for

AP/P/98/01363

1 managing a wireless local loop system as well as a fixed wireless terminal which can be
2 remotely maintained and scanned for purposes of overall network management combines to
3 form an extremely cost effective communications system that significantly reduces the
4 problems associated with wired communications and the maintenance associated with such a
5 system. The overall architecture is a much more cost effective overall telecommunications
6 infrastructure that can be instituted in remote or rural areas or developing countries without
7 the added burden of stringing telephone wires over extended locations. Those skilled in the
8 art will appreciate that other similar implementations may be possible for such a wireless
9 communications infrastructure without departing from the spirit and the specification as
described.

AP/P/98/01363

1 We Claim:

2 1. A wireless telecommunications network comprising:
3 a plurality of wireless terminals WTs;
4 a plurality of base stations remotely connected to the WTs;
5 a network management computer connected to the base stations;
6 the network management computer adapted to send and receive signals from the WTs
7 via the base station to test and manage the operating characteristics of the WTs

8 2. The wireless telecommunications network of claim 1 wherein the WTs comprise:

9 an antenna;

10 an RF send/receive means connected to the antenna;

11 a programmable digital signal processor DSP connected to the RF send/receive
12 means; and

13 a telephone interface connected to the programmable DSP adapted to be connected to
14 standard telephones.

15 3. The wireless telecommunications network of claim 2 wherein the programmable DSP
16 comprises:

17 memory for storing instructions; and

18 instructions for managing and testing the operation of the WT stored in the memory.

19 4. The wireless telecommunications network of claim 3 wherein the programmable DSP
20 further comprises instructions for communicating the results of the telecommunications
21 testing to the network management computer.

22
23 5. The wireless telecommunications network of claim 4 wherein the instructions for
24 communicating with the network management computer causes communication with the

1 network management computer regarding operational characteristics of the WT to occur in
2 response to a query from the network management computer.

3 6. The wireless telecommunications network of claim 4 wherein the instructions for
4 communicating with the network management computer causes communication with the
5 network management computer regarding operational characteristics of the WT to occur on a
6 preset schedule.

7 7. The wireless telecommunications network of claim 4 wherein the instructions for
8 communicating with the network management computer causes communication with the
9 network management computer regarding operational characteristics of the WT to occur as a
10 result of a finding by the programmable DSP of an out-of-specification condition of the WT
11 in which the programmable DSP is located.

12 8. The wireless telecommunications network of claim 4 wherein the instructions for
13 communicating with the network management computer causes communication with the
14 network management computer as a result of successful WT initialization in which the WT
15 informs the network management computer that it is ready to be included in the network.

16 9. The wireless telecommunications network of claim 7 wherein the WT is capable of
17 receiving responses from the network management computer to communication of the out-of-
18 specification condition previously detected within the WT by the associated programmable
19 DSP

20 10. The wireless telecommunications network of claim 1 wherein the network
21 management computer further comprises memory and instructions stored in the memory for
22 polling the WTs to determine their operational characteristics.

23 11. The wireless telecommunications network of claim 1 wherein the network
24 management computer further comprises means for receiving signals from the WTs

AP/P/ 98 / 0 1 3 6 3

1 concerning the operational characteristics of the WTs based on a schedule of reporting from
2 the WTs.

3 12. The wireless telecommunications network of claim 1 wherein the network
4 management computer further comprises means for receiving the communication from the
5 WTs that experience an out-of-specification condition of the WT sensed by the associated
6 programmable DSP.

7 13. The wireless telecommunications network of claim 2 wherein the operating
8 parameters of the WTs are established at the site of the WT.

9 14. The wireless telecommunications network of claim 13 wherein the operating
10 parameters of the WTs are established via inputs from the group comprising DTMF and pulse
11 inputs to the programmable DSP of the WT via the telephone interface.

12 15. The wireless telecommunications network of claim 2 wherein the operating
13 parameters of the WTs are established by the network management computer and
14 communicated to the WTs over the air.

15 16. The wireless telecommunications network of claim 2 wherein the network
16 management computer comprise means for receiving alarms regarding out-of-specification
17 conditions from the WTs and further comprising means for making decisions regarding how
18 to react to the alarms, and means for communication the decisions to the WTs.

19 17. The wireless telecommunications network of claim 3 wherein the programmable DSP
20 further comprises programmable dialing rules.

21 18. The wireless telecommunications network of claim 3 wherein the programmable DSP
22 dialing rules may be changed in response to communications from the network management
23 computer.

24 19. A method of establishing and monitoring a wireless telecommunications network

- 1 comprising:
- 2 establishing the operational characteristics of a plurality of WTs in a network;
- 3 receiving the operational characteristics in the memory of the WTs;
- 4 monitoring the operational characteristics of the WTs;
- 5 communicating changes to operational characteristics to the WTs;
- 6 20. The method of establishing and monitoring a wireless telecommunications network
- 7 of claim 19 wherein establishing the operational characteristics is accomplished by providing
- 8 input to a DSP having a memory in a WT via a telephone interface.
- 9 21. The method of establishing and monitoring a wireless telecommunications network
- 10 of claim 20 wherein establishing the operational characteristics is accomplished via DTMF
- 11 input at the site of the WT.
- 12 22. The method of establishing and monitoring a wireless telecommunications network
- 13 of claim 20 wherein establishing the operational characteristics is accomplished via pulse
- 14 input at the site of the WT.
- 15 23. The method of establishing and monitoring a wireless telecommunications network
- 16 of claim 19 wherein the establishing the operational characteristics is accomplished over the
- 17 air via communication from the network management computer.
- 18 24. The method of establishing and monitoring a wireless telecommunications network
- 19 of claim 20 wherein the monitoring of the network is accomplished via communications sent
- 20 from the WTs to the network management computer concerning the operating characteristics
- 21 of the WTs in the network.
- 22 25. The method of establishing and monitoring a wireless telecommunications network
- 23 of claim 24 wherein the communications from the WTs occurs on a preset schedule.
- 24 26. The method of establishing and monitoring a wireless telecommunications network

AP/P/98/01363

1 of claim 24 wherein the communications from the WTs occurs in response a polling of the
2 WTs by the network management computer.

3 27. The method of establishing and monitoring a wireless telecommunications network
4 of claim 19 wherein the communications from the WTs occurs as a result of the associated
5 programmable DSP sensing an out-of-specification condition in the WT.

6 28. The method of establishing and monitoring a wireless telecommunications network
7 of claim 20 further comprising establishing flexible dialing rules in the memory of the DSP.

8 29. The method of establishing and monitoring a wireless telecommunications network
9 of claim 20 wherein the flexible dialing rules in the memory of the DSP are changed via
10 communication from the network management computer, and receiving the communication
11 from the network management computer into the memory of the DSP.

12
13
14
15

AP/P/98/01363

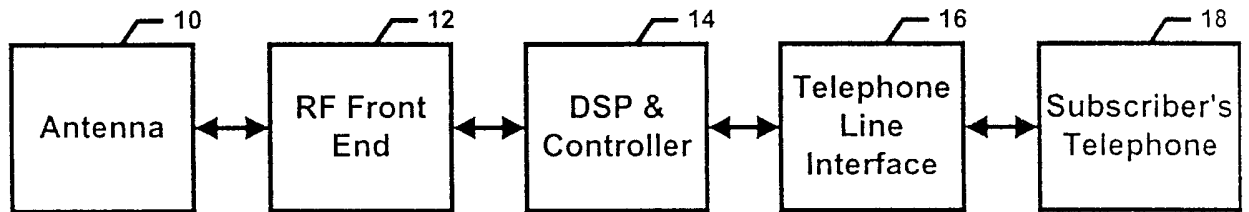
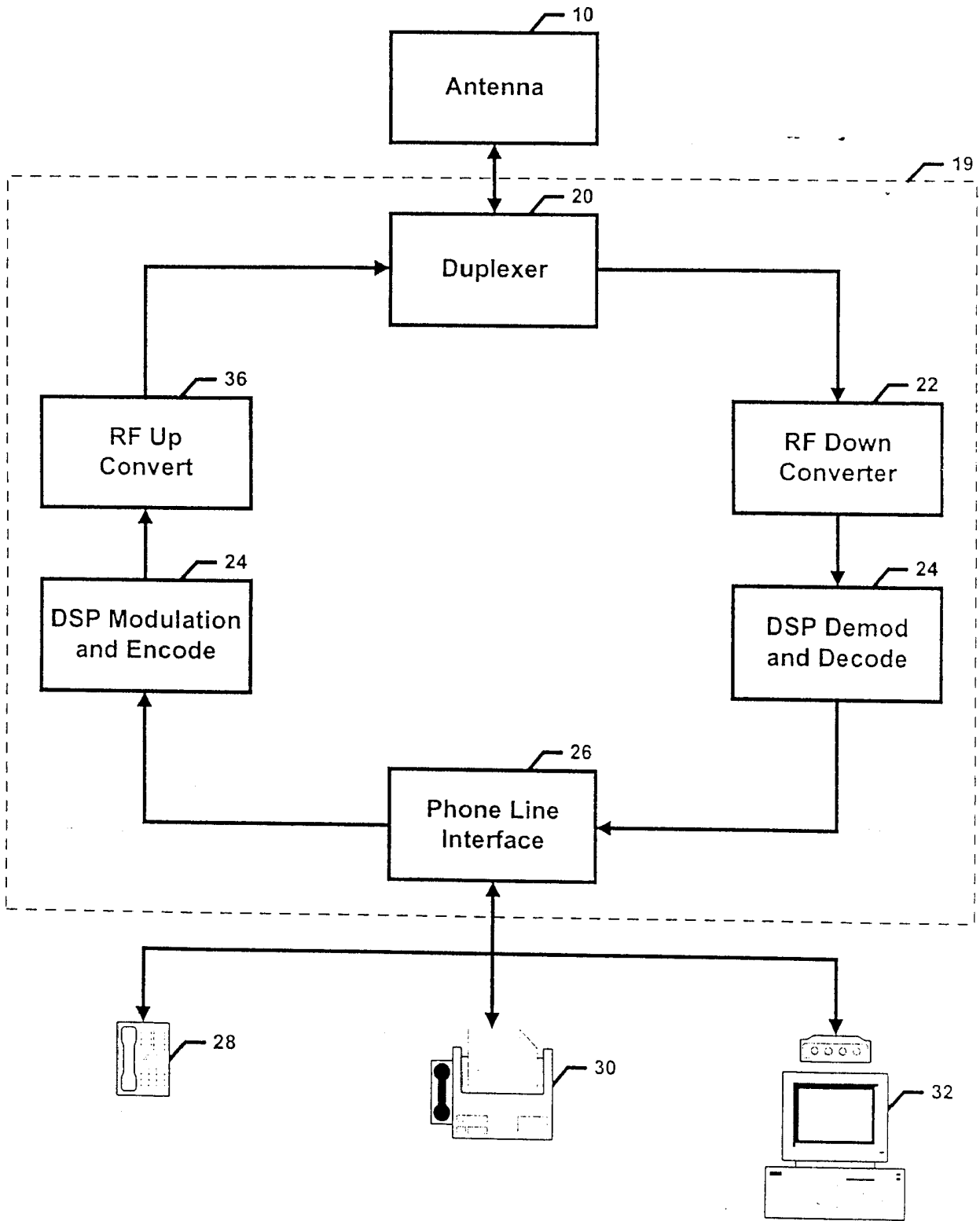
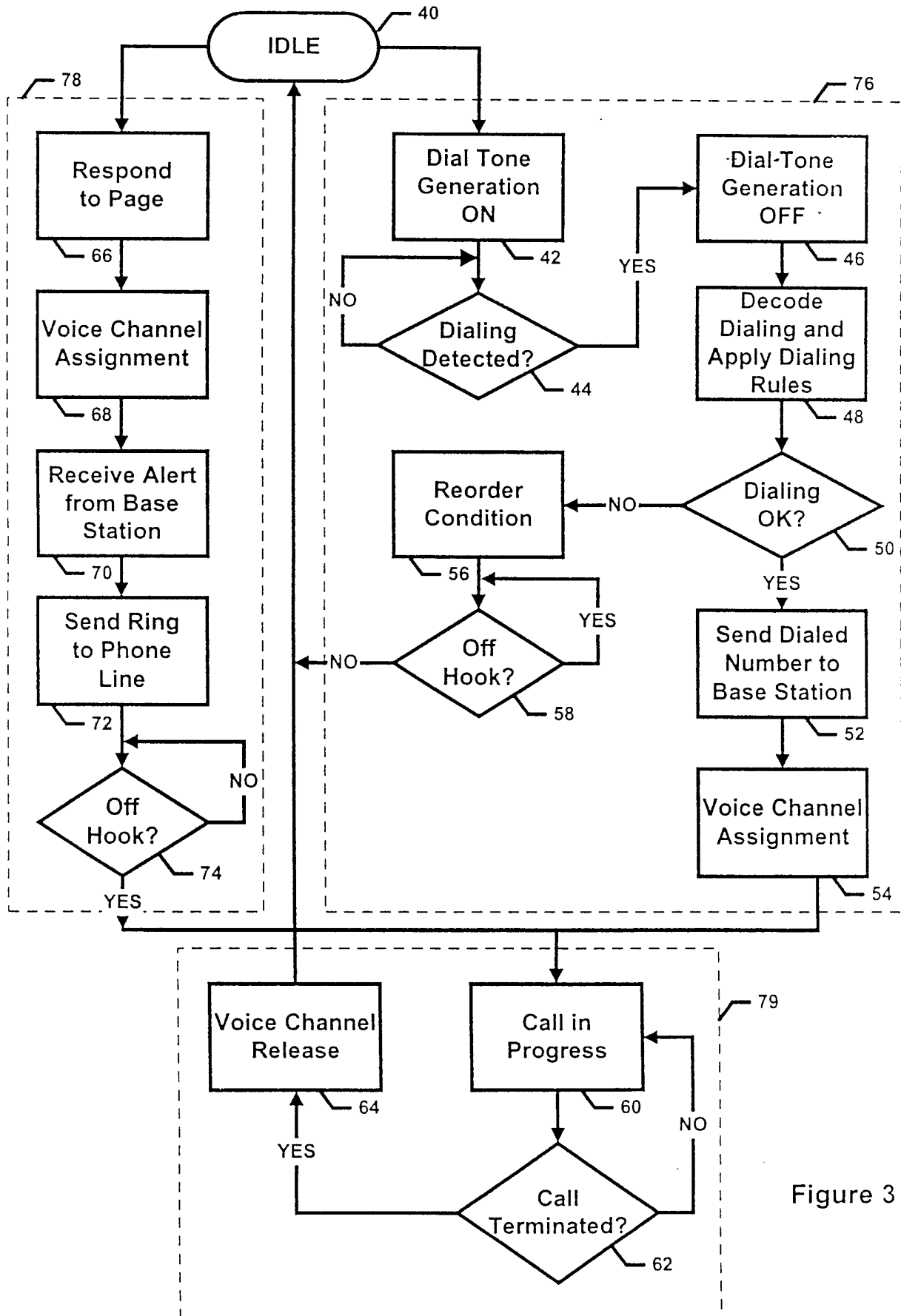

Figure 1



AP/P/98/01363

Figure 2



AP/P/98/01363

Figure 3

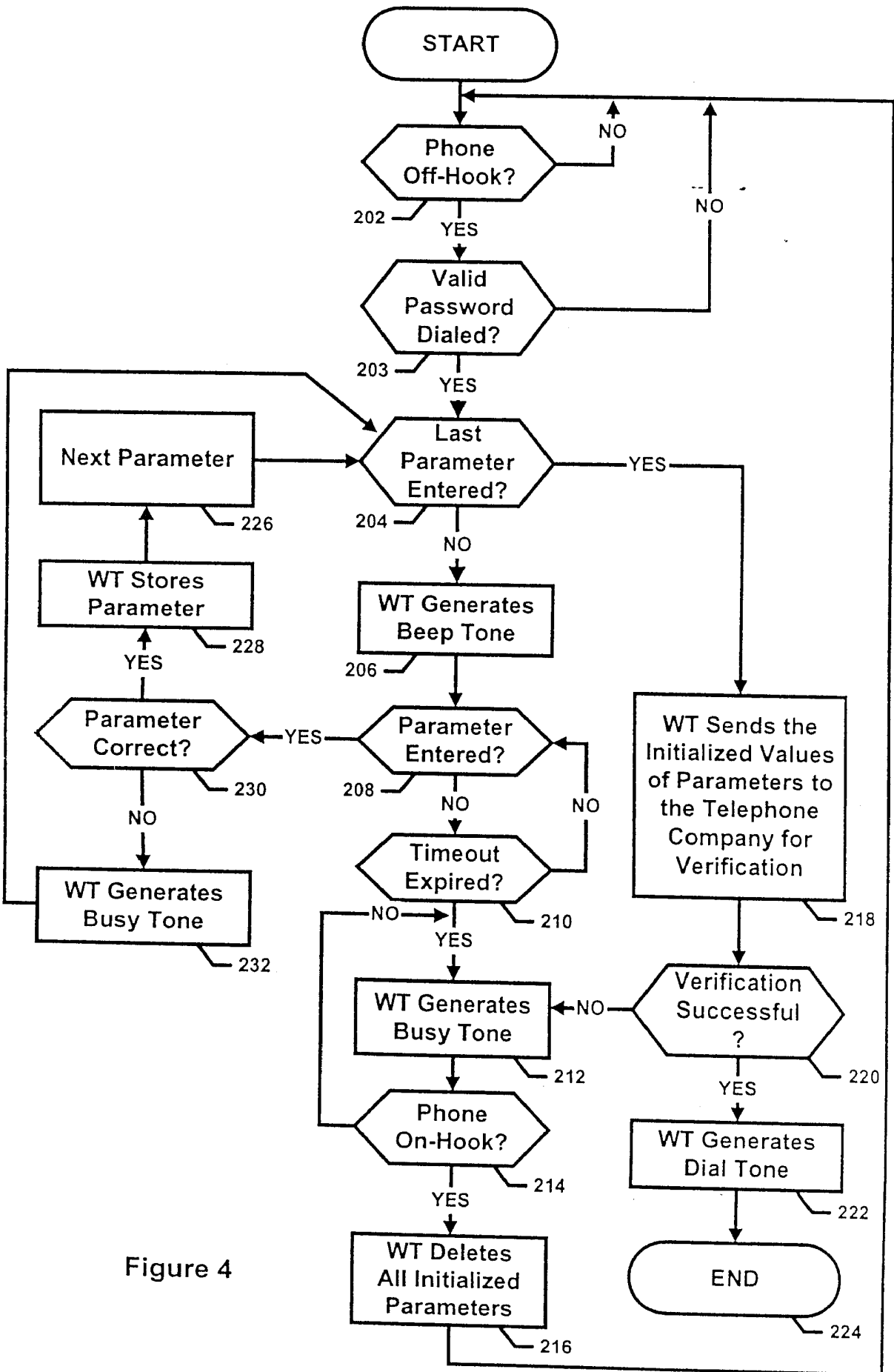
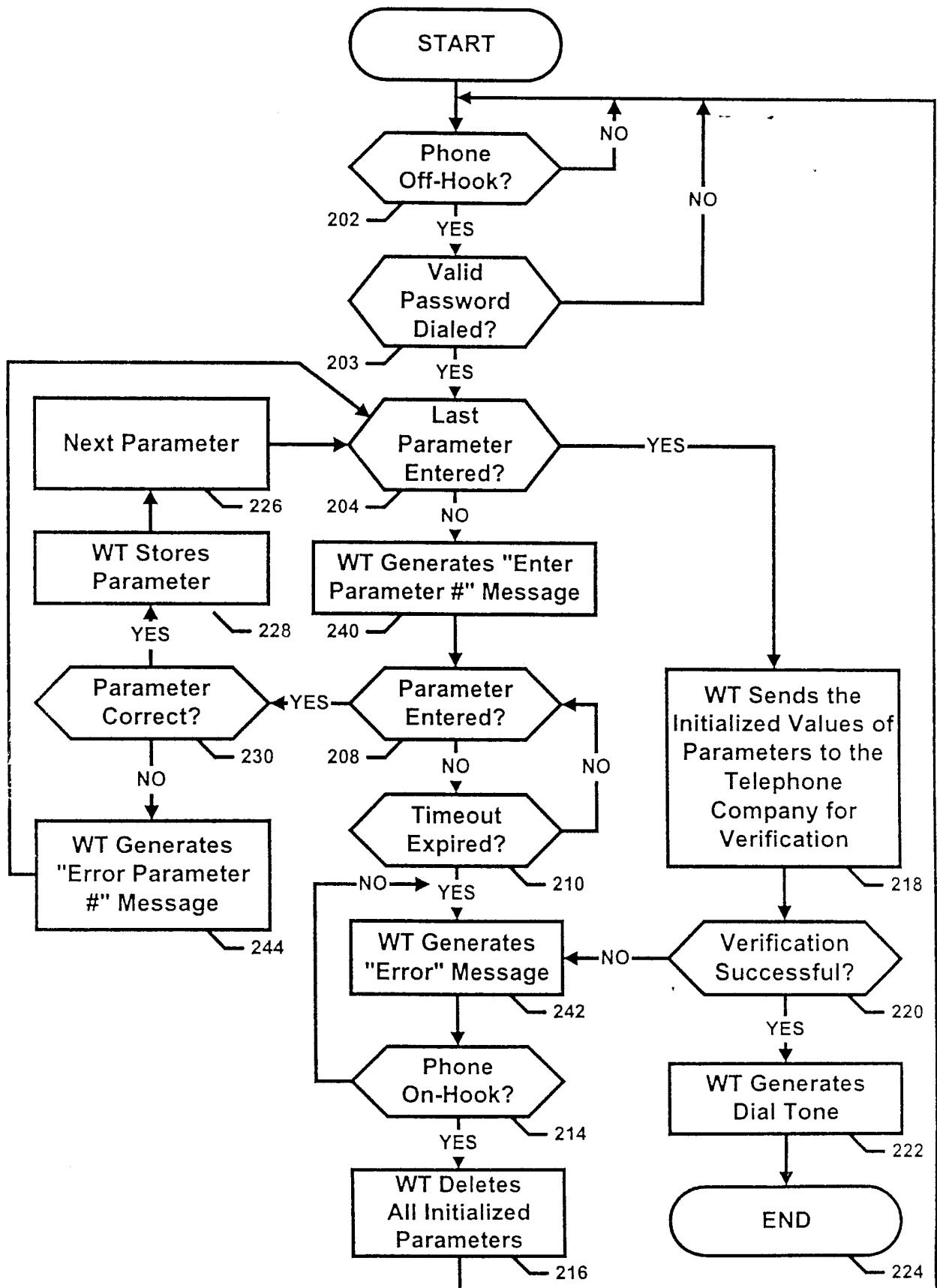

Figure 4

AP/P/98/01363



AP/P/98/01363

Figure 5

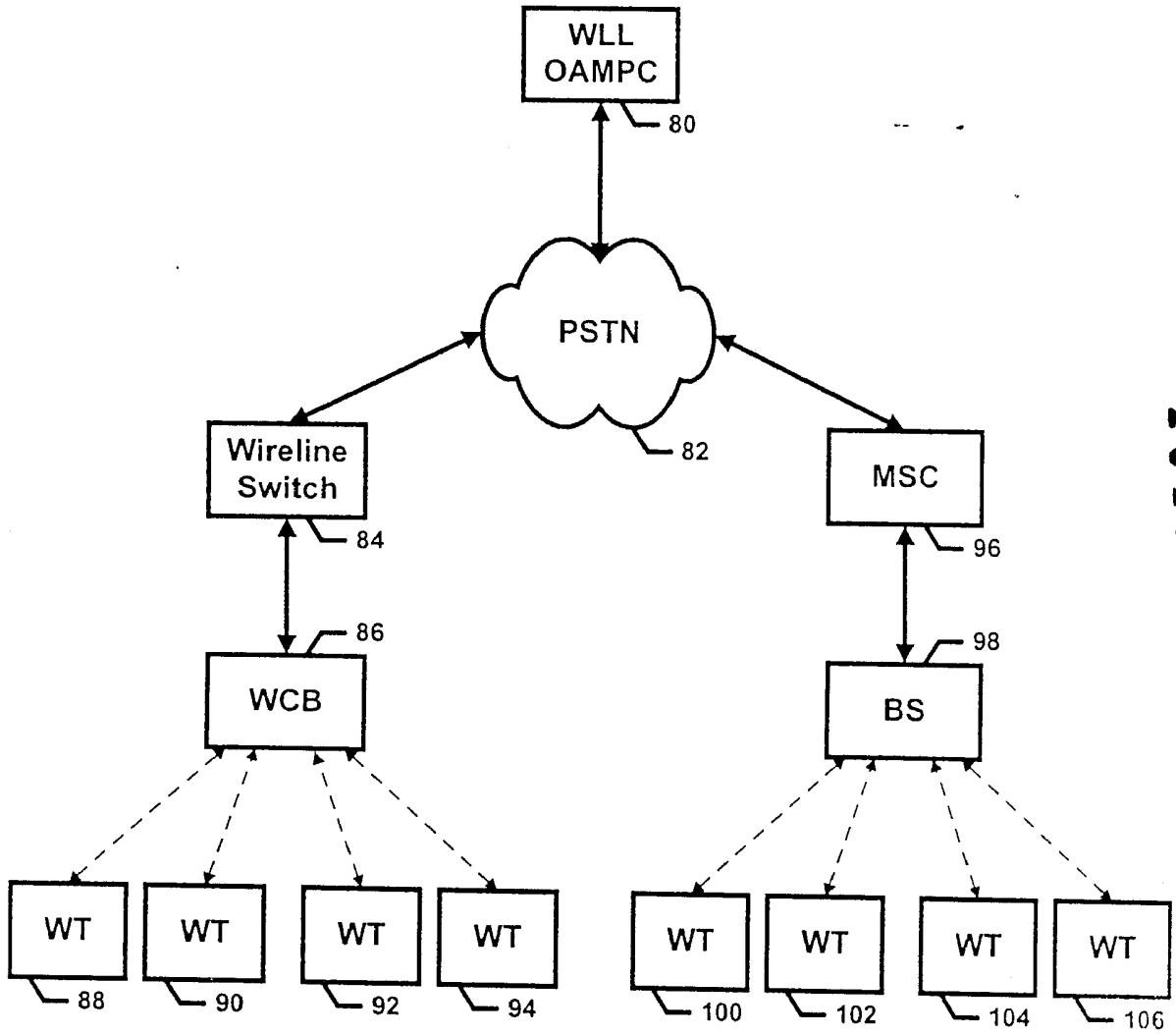

AP/P/98/01363

Figure 6

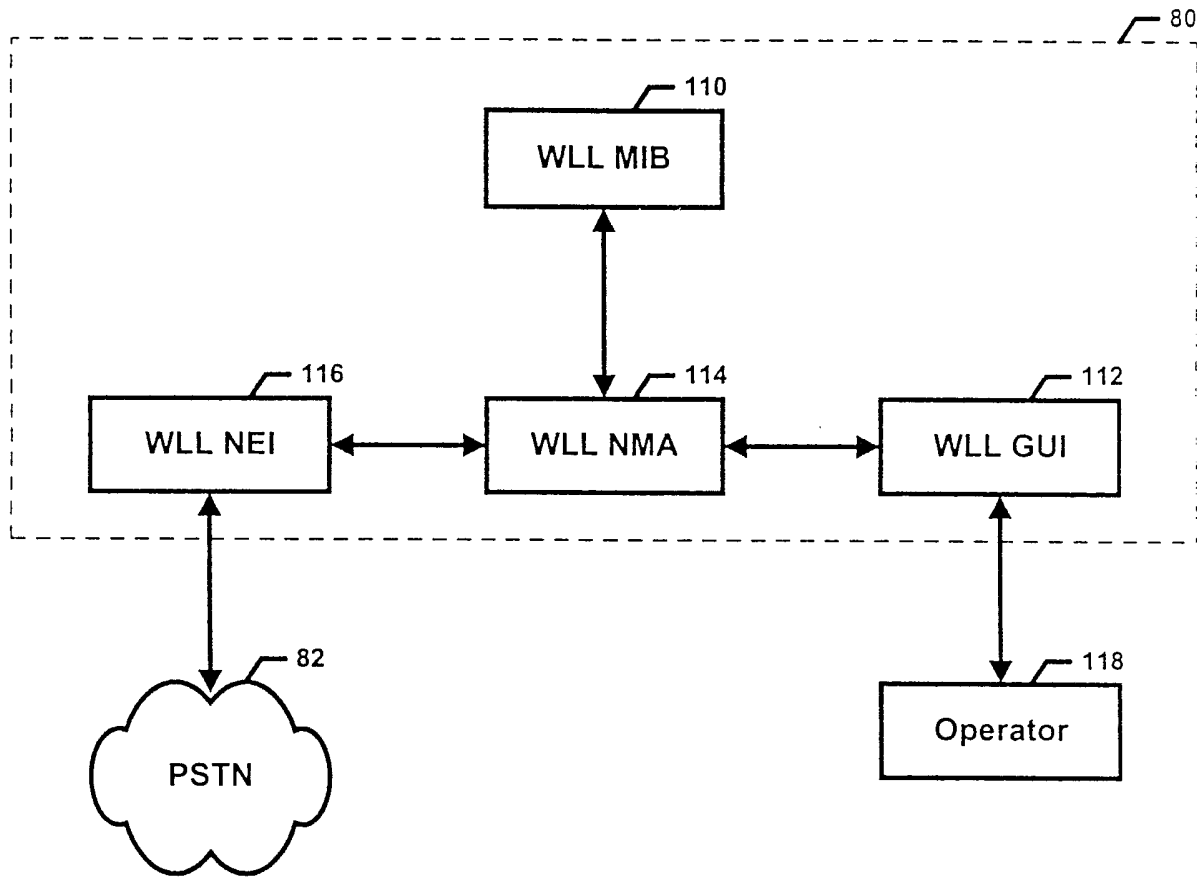

AP/P/98/01363

Figure 7

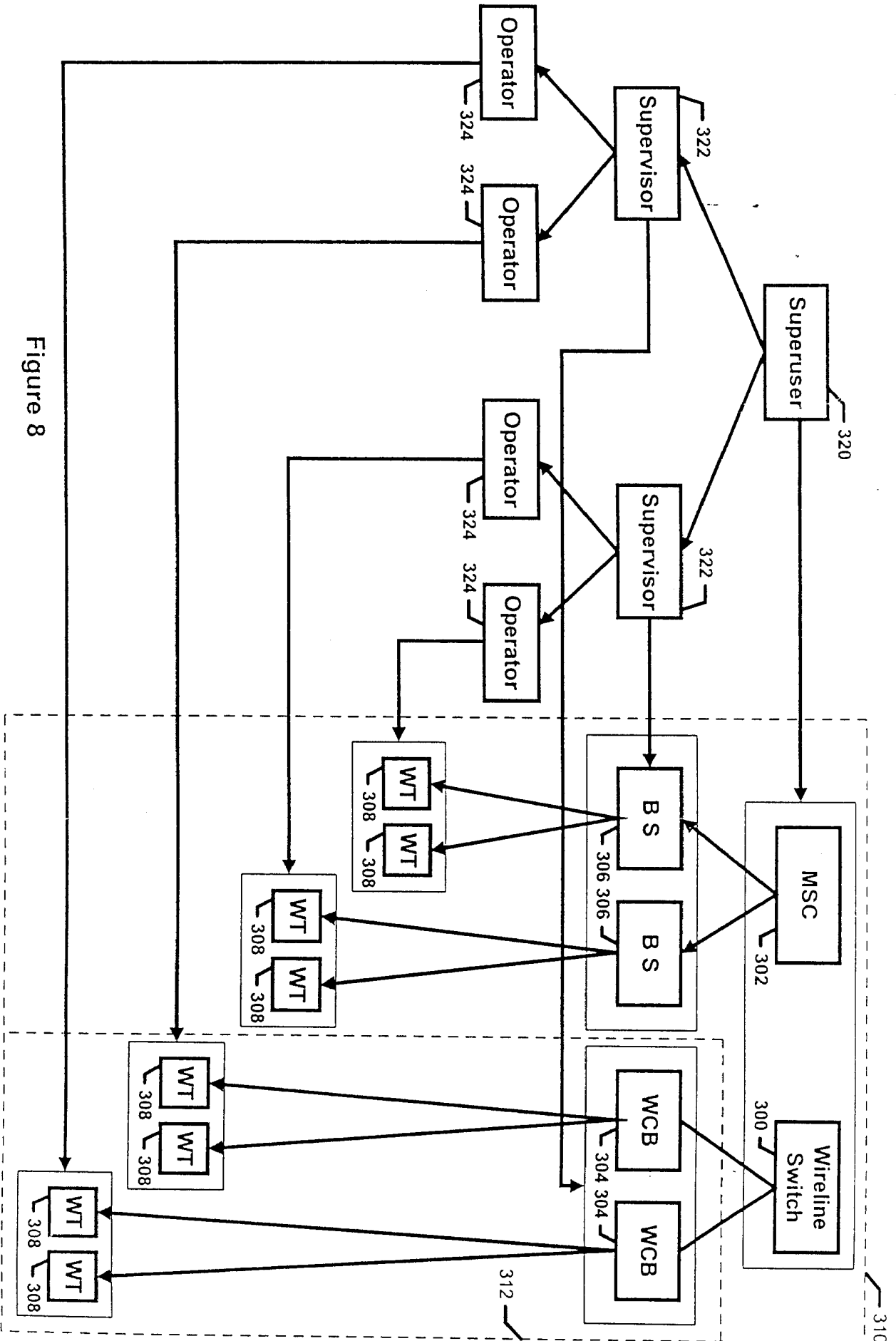

Figure 8

29510/86/P/A

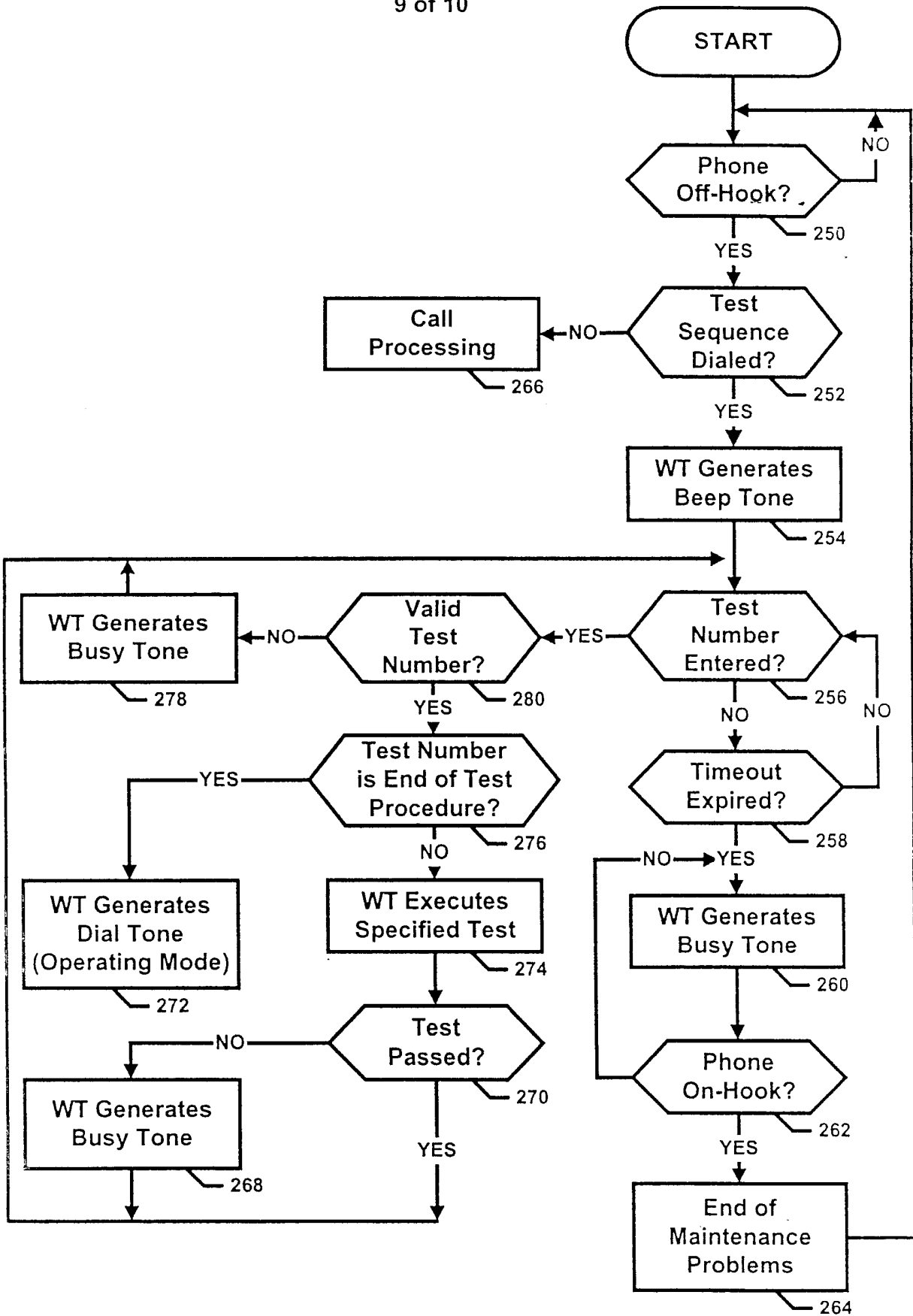

Figure 9

AP/P/98/01363

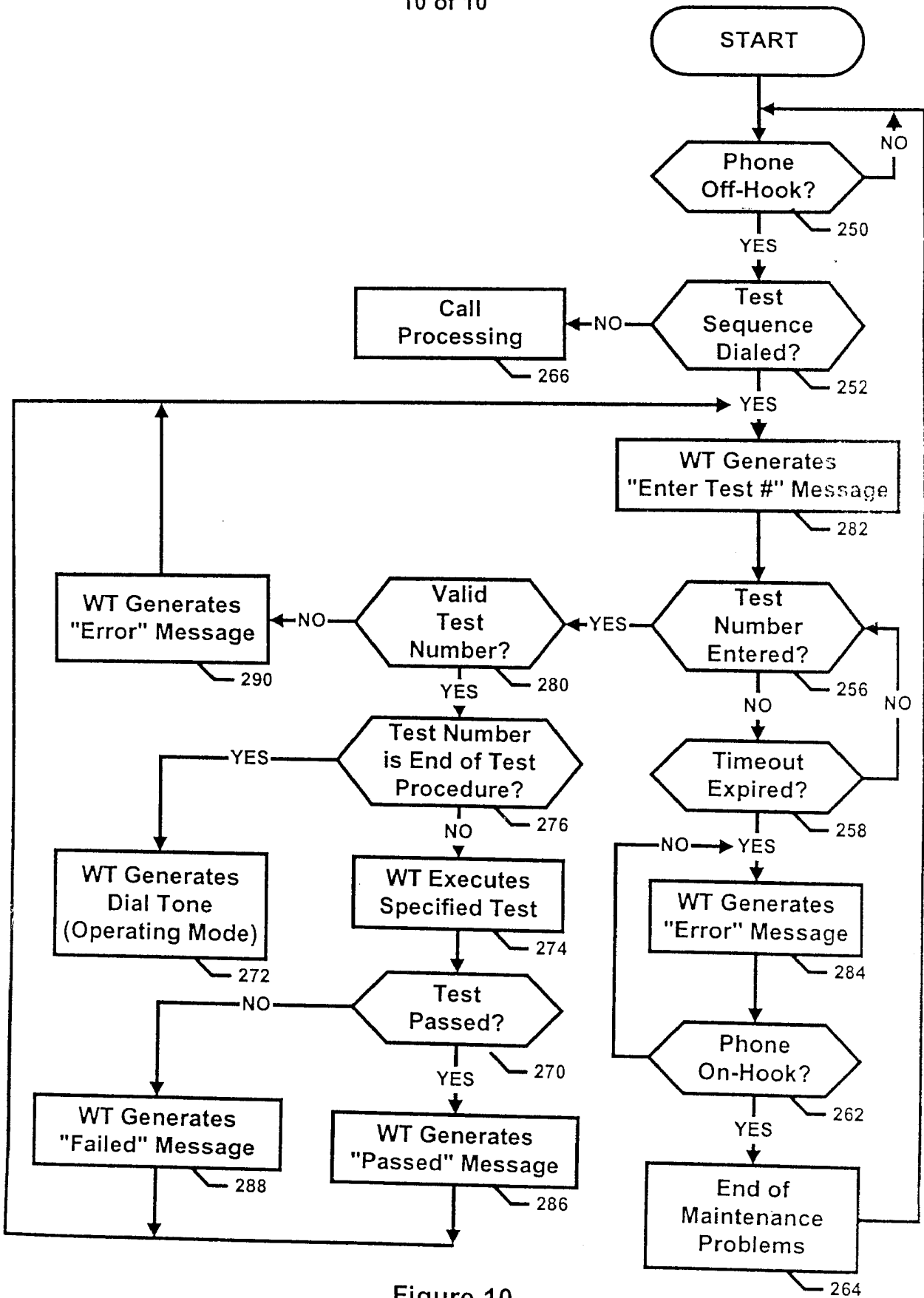

Figure 10

AP/P/98/01363