



INTERNATIONAL APPLICATION PUBLISHED UNDER THE PATENT COOPERATION TREATY (PCT)

<p>(51) International Patent Classification⁴ : G12B 15/02, H05K 7/20 H01L 23/46</p>	<p>A1</p>	<p>(11) International Publication Number: WO 89/ 00751</p> <p>(43) International Publication Date: 26 January 1989 (26.01.89)</p>
<p>(21) International Application Number: PCT/US88/02320</p> <p>(22) International Filing Date: 11 July 1988 (11.07.88)</p> <p>(31) Priority Application Number: 074,827</p> <p>(32) Priority Date: 17 July 1987 (17.07.87)</p> <p>(33) Priority Country: US</p> <p>(71) Applicant: ALLIED-SIGNAL INC. [US/US]; Law Department (C.A. McNally), P.O. Box 2245R, Morristown, NJ 07960 (US).</p> <p>(72) Inventors: AGEE, Keith, Dennis ; 2325 W. 180th Place, Torrance, CA 90504 (US). FAULKNER, Fredrik, Eugene ; 13 Dapplegray Lane, Rolling Hills Estates, CA 90224 (US).</p> <p>(74) Agent: WINTER, Richard, C.; Allied-Signal Inc., Law Department (C.A. McNally), P.O. Box 2245R, Morristown, NJ 07960 (US).</p>	<p>(81) Designated States: AT (European patent), BE (European patent), CH (European patent), DE (European patent), FR (European patent), GB (European patent), IT (European patent), JP, LU (European patent), NL (European patent), SE (European patent).</p> <p>Published <i>With international search report.</i> <i>Before the expiration of the time limit for amending the claims and to be republished in the event of the receipt of amendments.</i></p>	

(54) Title: COOLING SYSTEM FOR A SEALED ENCLOSURE

(57) Abstract

A cooling system for a sealed enclosure having heat generating equipment therein characterized by forced convection indirect cooling of the heat generating equipment combined with a natural convection external finned heat sink. The cooling system or heat exchanger is mounted to the wall of the sealed enclosure and includes two side plates which are mounted a spaced distance from one another. One side plate forms a portion of a wall of the sealed enclosure and has fin elements mounted on one side, which side is outside of the enclosure. Fin elements are mounted between the two side plates extending inwardly from opposing ends of the side plates a desired distance thereby forming a central plenum between the two sets of fin elements. A fan is mounted in a manner to draw air in between the side plates and return it to the enclosed environment.

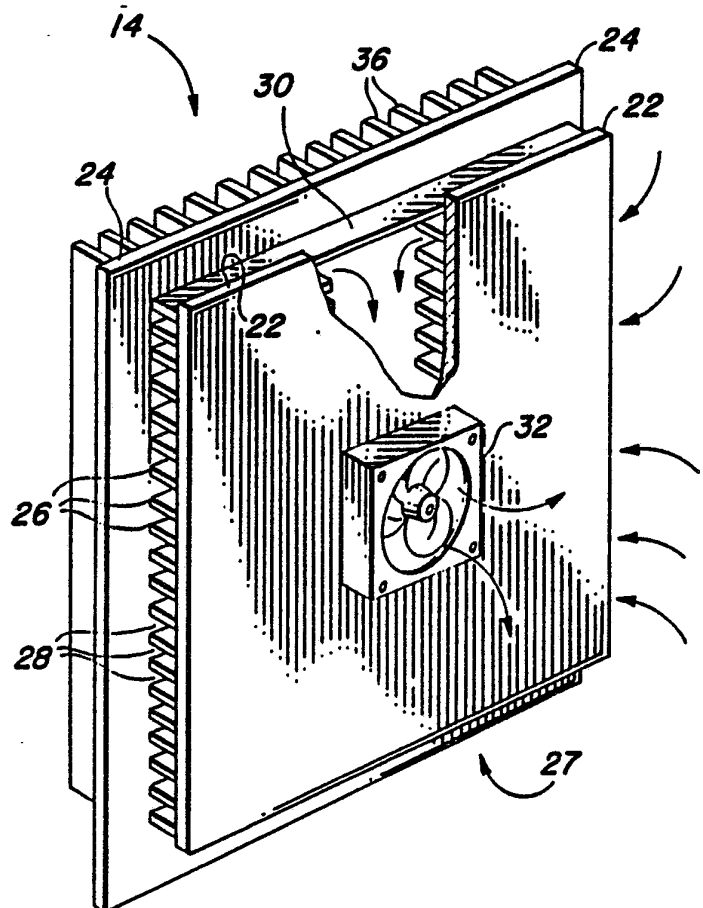

FOR THE PURPOSES OF INFORMATION ONLY

Codes used to identify States party to the PCT on the front pages of pamphlets publishing international applications under the PCT.

AT	Austria	FR	France	ML	Mali
AU	Australia	GA	Gabon	MR	Mauritania
BB	Barbados	GB	United Kingdom	MW	Malawi
BE	Belgium	HU	Hungary	NL	Netherlands
BG	Bulgaria	IT	Italy	NO	Norway
BJ	Benin	JP	Japan	RO	Romania
BR	Brazil	KP	Democratic People's Republic of Korea	SD	Sudan
CF	Central African Republic	KR	Republic of Korea	SE	Sweden
CG	Congo	LI	Liechtenstein	SN	Senegal
CH	Switzerland	LK	Sri Lanka	SU	Soviet Union
CM	Cameroon	LU	Luxembourg	TD	Chad
DE	Germany, Federal Republic of	MC	Monaco	TG	Togo
DK	Denmark	MG	Madagascar	US	United States of America
FI	Finland				

COOLING SYSTEM FOR A SEALED ENCLOSUREBACKGROUND OF THE INVENTION

05 The present invention relates to a heat exchanger and more particularly to a heat exchanger which combines forced convection indirect cooling of internal electrical components with a natural convection external finned heat sink.

10 In general, high power density electrical circuitry generates a large amount of heat and requires a cool, clean environment in order to function properly and reliably. Therefore, it is necessary to dissipate the
15 generated heat so as to use the circuitry in the manner intended, thereby lengthening the life of each component and increasing their reliability. Isolating the components from the environment eliminates moisture and dust, but greatly complicates the cooling of the circuitry since the components cannot be cooled directly.
20 Therefore, there is a need for a suitable apparatus which can cool electrical circuitry which is isolated from the environment.

SUMMARY OF THE INVENTION

20 It is an object of the present invention to provide a means for cooling electrical circuitry which is isolated from the environment.

25 It is another object of the present invention to provide a heat exchanger apparatus which combines forced convection indirect cooling of the electrical circuitry with an external finned heat sink cooled by natural convection.

30 It is a further object of the present invention to provide a cooling apparatus which can prolong the life of electrical circuitry and increase its reliability.

35 It is a still further object of the present invention to provide a heat exchanger apparatus which combines forced convection indirect cooling of electrical circuitry with natural convection cooling passages sandwiched between finned hot passages.

In accordance with the present invention the cooling system for sealed enclosures is used in

- 2 -

association with a sealed container having a heat
generating source therein. The cooling system or heat
exchanger is formed as part of one or more of the walls of
the sealed enclosure and includes a first and a second
05 side plate which are mounted in spaced, generally parallel
relationship to each other. Fin elements are mounted
between at least a portion of the two side plates and
their ends define the boundary of a central plenum area
between the side plates and the fine elements. A fan is
10 mounted to the first side plate over the central plenum in
order to draw hot enclosure air between the two side
plates. The air flows through passageways formed by the
fin elements and enters into the central plenum before
being drawn through the fan. The outer face of the second
15 side plate has a plurality of spaced fins or ribs attached
to form a finned wall section outside of the enclosure.
The second side plate is mounted so that it forms either
all or a portion of a wall of the sealed enclosure.

BRIEF DESCRIPTION OF THE DRAWINGS

20 These and other objects of the present invention
will become more readily apparent from the following
specification, with reference to the accompanying
drawings, in which:

Figure 1 is a perspective view of the cooling
25 system for a sealed enclosure according to the present
invention.

Figure 2 is an enlarged perspective view of the
heat exchanger of the cooling system with a cut out
section to show the central plenum.

30 Figure 3 is a front view of the heat exchanger
including several cut-out portions.

Figure 4 is a top view of the heat exchanger; and
Figure 5 is a side view of the heat exchanger.

35 Figure 6 is a partial view of the design of the
side plates and detailing an alternative heat exchanger
fin element configuration located between the two side
plates.

- 3 -

Figure 7 is a partial view of an alternative design of the fins or ribs attached to the second side plate.

05 Figure 8 is a perspective view of an alternative embodiment of the cooling system of the present invention.

Figure 9 is an enlarged perspective view of the alternative embodiment of the cooling system as shown in Figure 8.

DESCRIPTION OF THE PREFERRED EMBODIMENTS

10 Figure 1 illustrates a sealed enclosure 10 which includes a heat generating source 12, such as electrical circuitry, and a cooling system or a heat exchanger 14. The heat exchanger 14 can be formed either as a portion of one wall 16 of the enclosure 10 or the wall itself or
15 several heat exchangers can be mounted to one wall or several of the walls of the enclosure.

The heat exchanger 14 is shown in greater detail in Figures 2-6. As shown, the heat exchanger comprises a first and a second side plate, 22 and 24 respectively,
20 which are in generally spaced parallel relationship. Located between the two side plates are heat exchange fin elements 26, which together with the two side plates define a plurality of air passageways 28 therebetween. Heat exchange fin elements 26 can be individual fins or
25 more likely formed as part of a corrugated sheet which is placed between the two side plates and thereafter bonded together. As shown, the passageways 28 extend horizontally inward from the opposing ends of the heat exchanger 14 and each terminates a desired distance from
30 the edge of the side plate, thereby forming a central plenum 30 which is bounded by the two side plates 22 and 24 and the termination of the heat exchange fin elements 26. In this manner, in the preferred embodiment, there is a finned portion 27 on either side of the plenum 30. A
35 bar or flange 40 is attached to each side plate at the top and bottom of the first side plate. Flange 40 can also be formed integral to first side plate 22 as is explained below. A fan 32 is mounted to the inner face of the first

- 4 -

side plate 22 and is therefore located within the sealed enclosure 10. Side plate 22 includes an opening 31 to accommodate the fan 32, thereby allowing air flow from the central plenum 30 to be drawn into the fan 32.

05 The second side plate 24 forms a portion of the wall of the sealed enclosure 10. As shown, a plurality of ribs or fins 36 are attached to the outer face of second side plate 24. These fins 36 are shown to be arranged in parallel relationship and extending in the vertical
10 direction though any desired spacing and arrangement can be used to achieve the necessary heat transfer to the environment. However, ribs 36 extending in the vertical direction utilize the differential of air densities
15 between hot and cool air to set up air circulation up through the ribs. As noted above, the heat exchanger 14 and in particular second side plate 24 can form a portion of wall 16 or can form the wall itself. Furthermore, if
20 greater heat dissipation is necessary, several heat exchangers 14 can be used with a single sealed enclosure 10. Hence, the heat exchanger 14 can be formed and thereafter mounted within the allotted opening in the sealed enclosure.

 It is to be noted that while the preferred embodiment of Figures 2-13 show that the plenum 30 is
25 located between two finned portion 27, it could be located entirely to one side of the finned portion or at the top or bottom of the finned portion.

 Figure 6 details an alternate design of the finned portions 27 of heat exchanger 14. As shown, the
30 first side plate 22 includes the flange 40 having an integral tab member 41 attached to the top and bottom edge thereof. The flange 40 is bent approximately perpendicular to side plate 22 and tab member 41 is formed so that it is approximately perpendicular to the flange 40
35 and parallel to side plate 22. This design provides for ease of brazing or welding tab members 41 of the first side plate 22 to the second side plate 24. As shown in Figure 6, each of the finned portions 27 comprises two

- 5 -

corrugated fin elements 42 and 44 having a thin-walled plate 46 therebetween. The design can be changed in order to meet the heat transfer characteristics necessary to cool the air held within the enclosure.

05 Figure 7 details an alternative design for the fins 36 which are attached to the outer face of second side plate 24 and are therefore located outside the enclosure 10. As stated above, the fins are preferably arranged vertically in order to allow the hotter air to
10 rise thereby creating circulation of ambient air. However, in order to increase the heat transfer to the ambient air, the fins 36 are formed with cutouts 50 which increase the air turbulence flowing between adjacent fins 36.

15 Upon operation of the heat generating source 12 in the sealed enclosure 10, heat is dissipated to the air therein, which is drawn by the fan 32 through the passageways 28 formed by heat exchange fin elements 26 on each side of the heat exchanger 14. The relatively hot
20 enclosure air gives up some of the heat by forced convection to the heat exchange fin elements 26 which in turn conduct the heat to the ribs or fins 36 attached to the second side plate 24. The heat is in turn transmitted to the environment by natural convection and radiation.
25 The relatively cool enclosure air exiting the passageways 28 enters the central plenum 30 and is thereafter drawn into the fan 32 and returned to an area of the sealed enclosure 10 having relatively hot enclosure air. At
30 steady state operation of the heat generating source, all of the heat produced by the heat generating source 12 and fan 32 will be transmitted to the environment via the fins 36.

35 Figures 8 and 9 show an alternative embodiment of the cooling system of the present invention. As shown, the cooling system 60 operates using the same principals as in the case of the preferred embodiment. These principals are forced convection indirect cooling of the

- 6 -

heat generating equipment combined with a natural convection external finned heat sink.

In this embodiment, the cooling system 60 includes a heat exchanger core 62 having an inlet and outlet manifold 64 and 66 respectively at opposite ends thereof. The heat exchanger core is of the cross-flow type having alternating channels of perpendicular directions of flow. The core 62 comprises plate-fin elements 68 which are oriented in an alternating stack or array with plate-fin elements 70 and the stacked plate-fin 68 and 70 separated from each other by a plurality of relatively thin end and lightweight divider plates 72 of a heat conductive material such as copper or aluminum. The plate-fin elements 68 and 70 form a plurality of air passages, 69 and 71 respectively, within the alternating channels, which channels are sealed from adjacent channels.

The entire stack including the plate-fin elements 68 and 70 and the divider plates 72 is in turn sandwiched between a pair of protective side plates 74 and 75. These side plates are also formed of a heat conductive material. As drawn, there are only two sets of plate-fin elements 68 and 70, however, it should be understood that any number could be used depending on size and the amount of heat to be dissipated.

Manifolds 64 and 66 are shown to be triangular in cross-section but can be formed into any design which leads the air into and out of the heat exchanger core 62. The outlet manifold 66 includes a fan 78. The outlet manifold is sealed except for an opening for the fan 78 such that all air drawn into the inlet manifold 64 passes through the fan 78.

As with the preferred embodiment, the relatively hot enclosure air is drawn through the heat exchanger core 62 where it transfers its heat to the corrugated fin elements 70 which in turn conduct it to the cooler core surfaces. Outside of the sealed enclosure, cooler environmental air passes upwardly through the vertically extending passages 69. Through natural convection the

- 7 -

heat is thereafter transferred to the environmental air. This gradual increase in air temperature will induce a flow of cool air into the bottom of the passages 69, thereby continuously circulating environmental air into
05 the core.

Various modifications to the depicted and described apparatus will be apparent to those skilled in the art. Accordingly, the foregoing detailed description of the preferred embodiment should be considered exemplary
10 in nature and not as limiting to the scope and spirit of the invention as set forth in the appended claims:

15

20

25

30

35

We Claim:

1. A cooling system for a sealed enclosure having a heat generating source therein:

05 means, within said sealed enclosure, for cooling the heat generating source by indirect forced convection; and

means, external to said sealed environment, for dissipating said heat to the environment by natural convection.

10 2. The system according to Claim 1 wherein said means for cooling comprises:

heat exchanger means for absorbing heat from the air within said sealed enclosure; and

means for drawing air through said heat exchanger means.

15 3. The system of Claim 2 wherein said heat exchanger means comprises:

a first and a second side plate;

20 a flange member secured between said two side plates along the top and bottom edge of said side plates thereby securing and spacing said side plates a fixed distance from one another and defining a plenum therebetween; and

25 heat exchange fin elements located between at least a portion of said side plates, said elements extending into said plenum a desired distance generally parallel to said flange members.

30 4. The system of Claim 3 wherein said flange member includes an integral tab member which extends the length of the flange member and is generally perpendicular thereto, said tab member being secured to one of said side plates.

5. The system of Claim 2 wherein said means for drawing comprises a fan mounted over an opening in said first side plate.

35 6. The system of Claim 1 wherein said means for cooling comprises:

- 9 -

a pair of side plates mounted in parallel spaced relationship thereby forming a plenum therebetween, said first side plate having an opening therein;

05 a flange member secured between said two side plates along the top and bottom edge of at least one side plate;

10 heat exchange fin elements located between at least a portion of said side plates; said heat exchange fin elements extending inwardly from opposing ends of the plenum a desired distance, said fin elements defining a plurality of horizontally extending passageways which terminate in a central plenum defined by the side plates, the flange members, and innermost ends of said heat exchange fin elements; and

15 a fan mounted to said first side plate over said opening, which opening extends into the central plenum.

20 7. The system of Claim 6 wherein said flange member is formed integral to said first side plate and includes a tab member which extends the length of the flange member and is generally perpendicular thereto, said tab member being secured to said second side plate.

8. The system of Claim 7 wherein said heat exchange fin elements comprise a pair of corrugated heat exchange fin elements.

25 9. The system of Claim 1 wherein said means external to said enclosure comprises:

a plurality of fins arranged in spaced vertical relationship and attached to the surface of said second side plate which is outside of said sealed enclosure.

30 10. The system of Claim 9 wherein said plurality of fins include cutouts therein.

11. A heat exchanger to be used to cool the air within a sealed enclosure comprising:

35 a first and a second side plate, said first side plate including an opening therein;

means for spacing and securing said plates a spaced distance apart to form a plenum therebetween;

- 10 -

means for forming a plurality of horizontally extending passages between said side plates;

fins attached to the second side plate on its surface which is opposite said plenum; and

05 a fan mounted to said first side plate and over said opening.

12. The heat exchanger of CLaim 10 wherein said means for spacing and securing comprises:

10 flange members attached to said first side plate on two opposing sides thereof, said flange member bent generally 90° to said side plates and including a tab member running the length of the flange and attached to said second side plate, said tab member bent approximately 90° to said flange member and generally parallel to said
15 side plates.

13. A cooling system for a sealed enclosure having a heat generating source therein, said cooling system comprising:

20 a first and a second side plate, said second side plate forming a portion of a wall of said enclosure; said first side plate having an opening therethrough;

25 a flange member extending the length of the first side plate and secured to said side plates along the top and bottom edge of said first side plate, thereby securing the side plates a spaced distance from one another and defining opposing open ends;

30 a heat exchange fin elements extending horizontally between said two side plates from said open ends a desired distance thereby forming a central plenum between said side plates, flange members and heat exchange elements;

a fan mounted to said first side plate over said opening, which opening is positioned over said central plenum;

35 fins attached to said second side plate on its outer surface, said fins being mounted in spaced relationship and generally in the vertical direction.

- 11 -

14. A method of cooling the air in a sealed enclosure, which enclosure includes a heat generating source therein, said method comprising the steps of:

05 cooling the heat generating source by indirect forced convection; and

dissipating the heat in the enclosure to the environment by natural convection.

15. The method of Claim 14 wherein the step of cooling comprises the steps of:

10 drawing relatively hot enclosure air through a plurality of passageways formed by heat exchange fin elements, thereby allowing the relatively hot air to transfer heat to the fin elements;

15 collecting the relatively cool air exiting the passageways; and

drawing said relatively cool air exiting the plurality of passageways through a fan blowing it into an area of the sealed enclosure having relatively hot air.

20 16. The system of Claim 2 wherein said heat exchanger means comprises:

a first and a second side plate, said first side plate forming a portion of the enclosure wall;

25 a plurality of alternating cross-flow channels sealingly separated from adjacent channels and extending in parallel relationship with said side plates.

inlet manifold means for directing enclosure air into alternative channels;

outlet manifold means for collecting the enclosure air.

30 17. The system of Claim 16 wherein said means for drawing air comprises a fan mounted to said outlet manifold means.

18. The system of Claim 16 further comprising plate-fin elements within each of said channel.

35

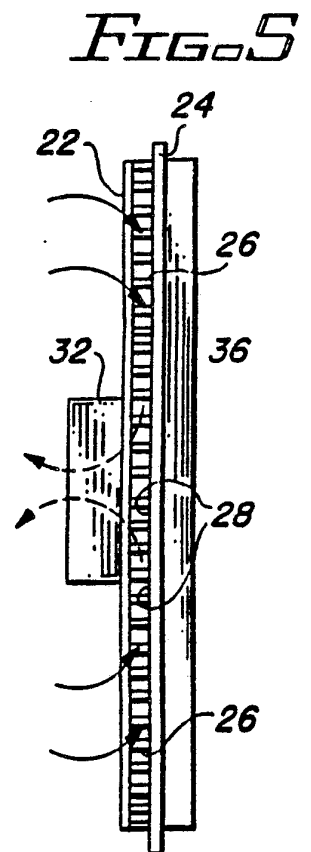
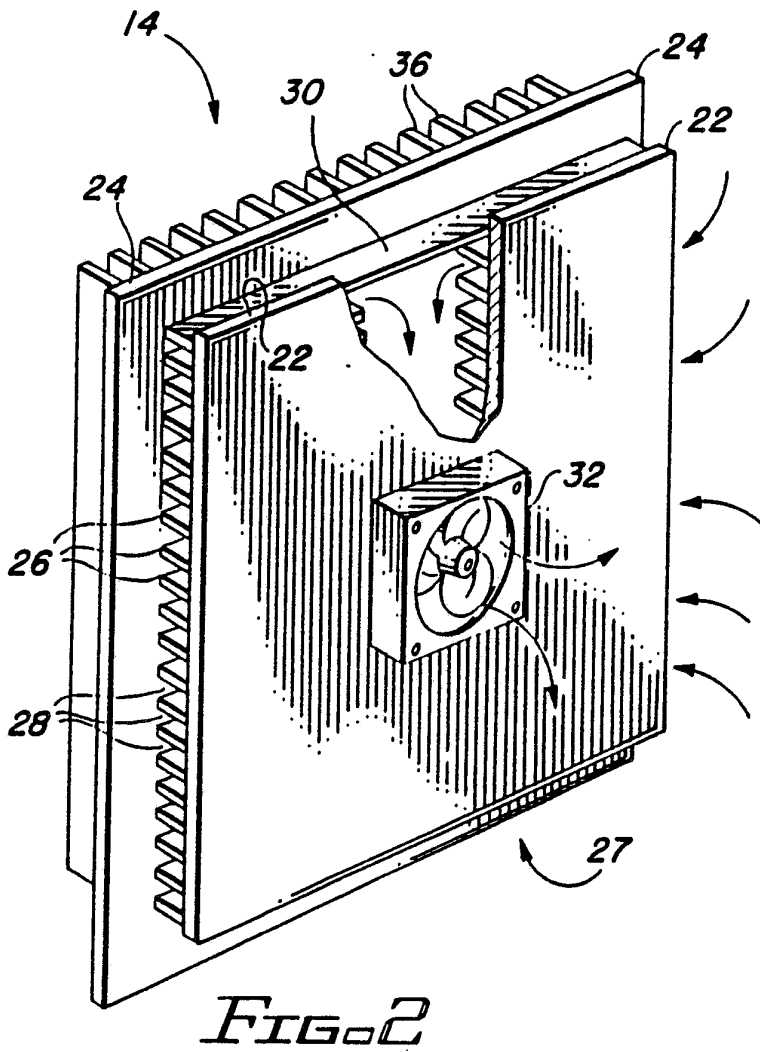
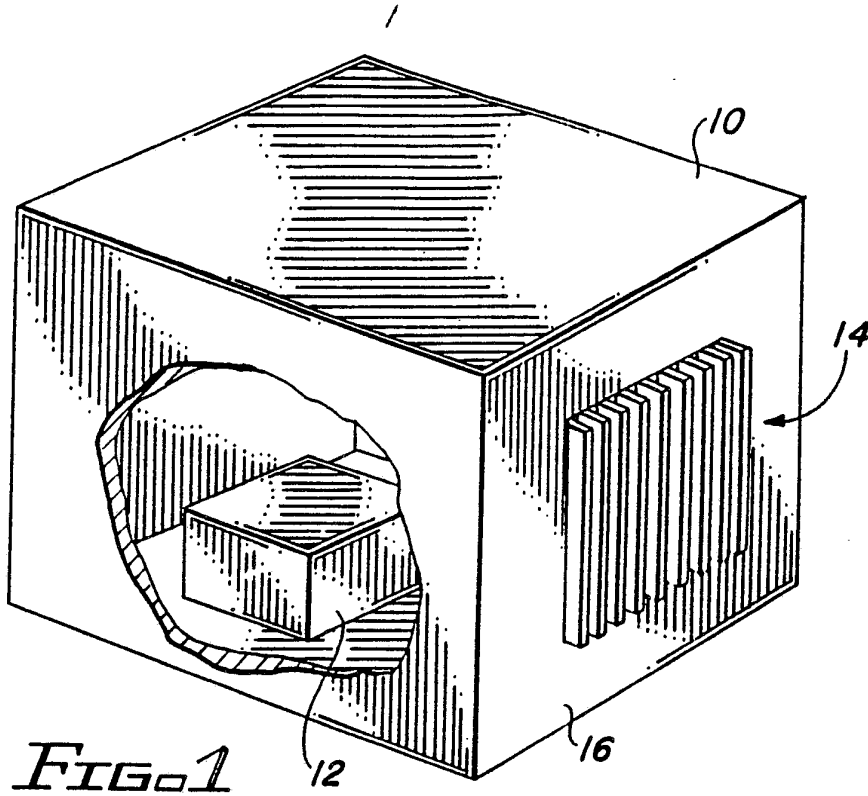

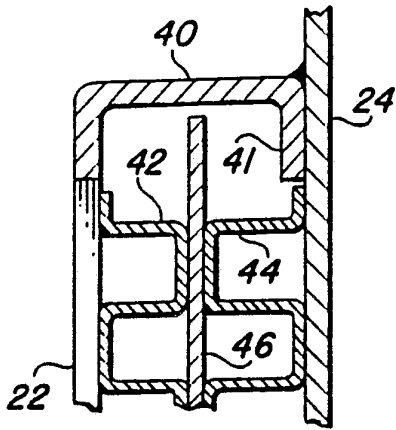

FIG. 6

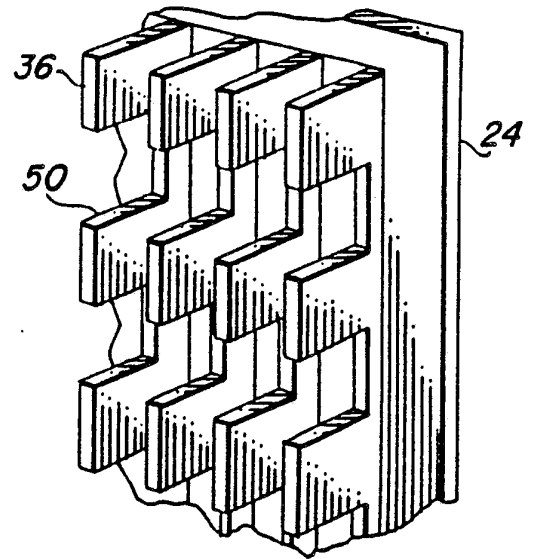

FIG. 7

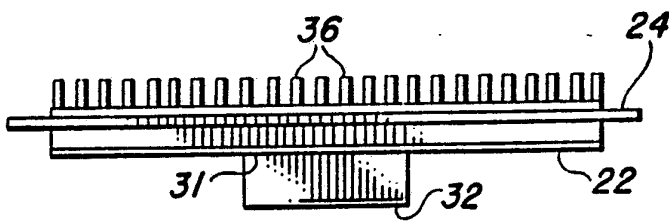

FIG. 4

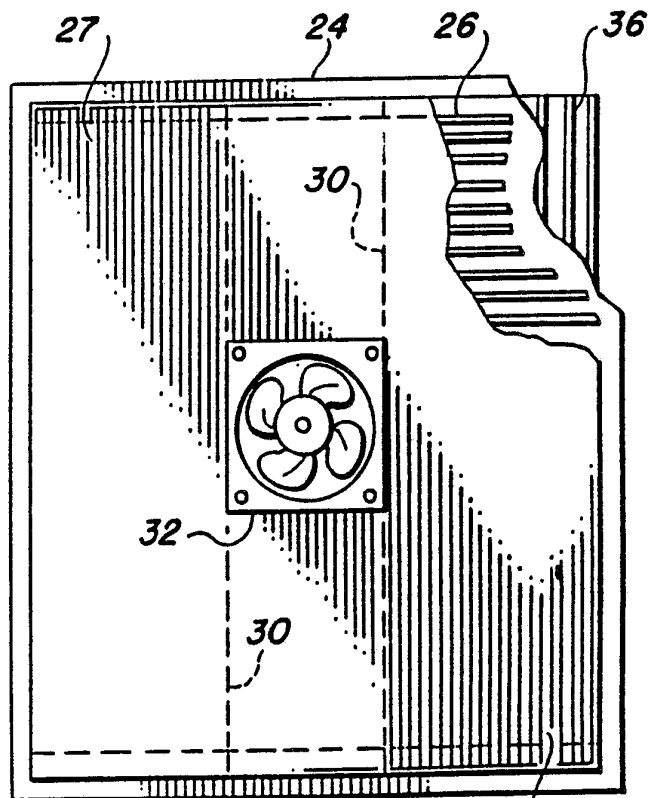

FIG. 3

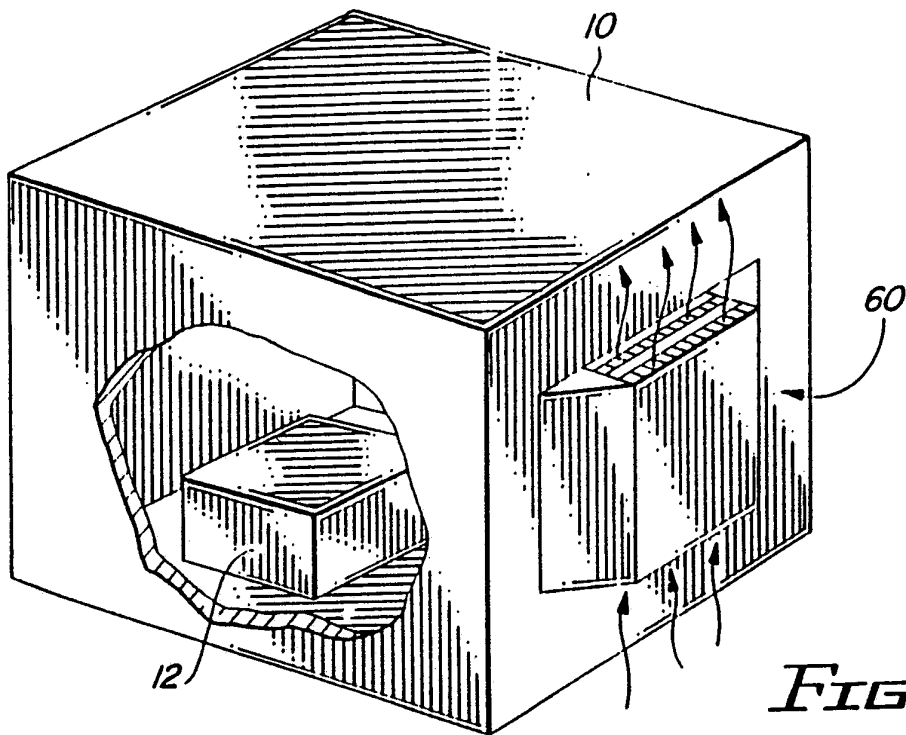

FIG. 8

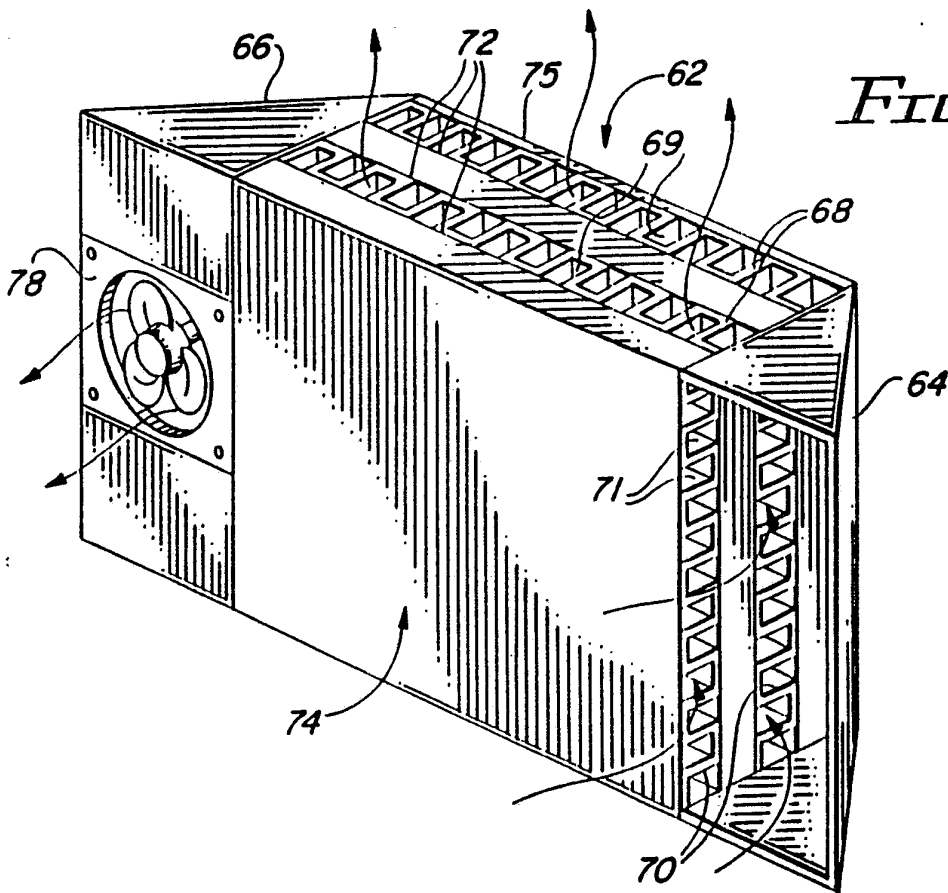
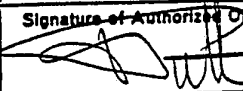

FIG. 9

INTERNATIONAL SEARCH REPORT

International Application No PCT/US 88/02320

I. CLASSIFICATION OF SUBJECT MATTER (if several classification symbols apply, indicate all) ⁶				
According to International Patent Classification (IPC) or to both National Classification and IPC				
IPC ⁴ : G 12 B 15/02, H 05 K 7/20, H 01 L 23/46				
II. FIELDS SEARCHED				
Minimum Documentation Searched ⁷				
Classification System	Classification Symbols			
IPC ⁴	G 12 B, H 05 K, H 01 L			
Documentation Searched other than Minimum Documentation to the extent that such Documents are included in the Fields Searched ⁸				
III. DOCUMENTS CONSIDERED TO BE RELEVANT ⁹				
Category ⁹	Citation of Document, ¹¹ with indication, where appropriate, of the relevant passages ¹²	Relevant to Claim No. ¹³		
X	EP, A2, 0112994 (K00), 11 July 1984, see figures 1, 2 and 3 and abstract	1-18		
X	--			
X	EP, A2, 0057411 (TOKYO SHIBAURA DENKI KABUSHIKI KAISHA) 11 August 1982, see figure 1 and abstract	1		
X	--			
X	DE, A1, 3030136 (REEH) 11 March 1982, see figure 2 and page 9-10	1		
X	--			
X	IBM Technical Disclosure Bulletin, vol. 9, no. 3, August 1966, page 342, Chu: "Thermoelectric Cooling for Memory Arrays", the whole article	1		
X	--			
X	Patent Abstracts of Japan, vol. 9, no. 295 (E-360), abstract of JP 60-134450, 17 July 1985 *abstract*	1		
X	--			
<table style="width: 100%; border: none;"> <tr> <td style="width: 50%; border: none; vertical-align: top;"> <ul style="list-style-type: none"> • Special categories of cited documents: ¹⁶ "A" document defining the general state of the art which is not considered to be of particular relevance "E" earlier document but published on or after the international filing date "L" document which may throw doubts on priority claim(s) or which is cited to establish the publication date of another citation or other special reason (as specified) "O" document referring to an oral disclosure, use, exhibition or other means "P" document published prior to the international filing date but later than the priority date claimed </td> <td style="width: 50%; border: none; vertical-align: top;"> <ul style="list-style-type: none"> "T" later document published after the international filing date or priority date and not in conflict with the application but cited to understand the principle or theory underlying the invention "X" document of particular relevance; the claimed invention cannot be considered novel or cannot be considered to involve an inventive step "Y" document of particular relevance; the claimed invention cannot be considered to involve an inventive step when the document is combined with one or more other such documents, such combination being obvious to a person skilled in the art. "G" document member of the same patent family </td> </tr> </table>			<ul style="list-style-type: none"> • Special categories of cited documents: ¹⁶ "A" document defining the general state of the art which is not considered to be of particular relevance "E" earlier document but published on or after the international filing date "L" document which may throw doubts on priority claim(s) or which is cited to establish the publication date of another citation or other special reason (as specified) "O" document referring to an oral disclosure, use, exhibition or other means "P" document published prior to the international filing date but later than the priority date claimed 	<ul style="list-style-type: none"> "T" later document published after the international filing date or priority date and not in conflict with the application but cited to understand the principle or theory underlying the invention "X" document of particular relevance; the claimed invention cannot be considered novel or cannot be considered to involve an inventive step "Y" document of particular relevance; the claimed invention cannot be considered to involve an inventive step when the document is combined with one or more other such documents, such combination being obvious to a person skilled in the art. "G" document member of the same patent family
<ul style="list-style-type: none"> • Special categories of cited documents: ¹⁶ "A" document defining the general state of the art which is not considered to be of particular relevance "E" earlier document but published on or after the international filing date "L" document which may throw doubts on priority claim(s) or which is cited to establish the publication date of another citation or other special reason (as specified) "O" document referring to an oral disclosure, use, exhibition or other means "P" document published prior to the international filing date but later than the priority date claimed 	<ul style="list-style-type: none"> "T" later document published after the international filing date or priority date and not in conflict with the application but cited to understand the principle or theory underlying the invention "X" document of particular relevance; the claimed invention cannot be considered novel or cannot be considered to involve an inventive step "Y" document of particular relevance; the claimed invention cannot be considered to involve an inventive step when the document is combined with one or more other such documents, such combination being obvious to a person skilled in the art. "G" document member of the same patent family 			
IV. CERTIFICATION				
Date of the Actual Completion of the International Search	Date of Mailing of this International Search Report			
31st October 1988	05 DEC 1988			
International Searching Authority	Signature of Authorized Officer			
EUROPEAN PATENT OFFICE	 P.C.G. VAN DER PUTTEN			

III. DOCUMENTS CONSIDERED TO BE RELEVANT (CONTINUED FROM THE SECOND SHEET)		
Category*	Citation of Document, with indication, where appropriate, of the relevant passages	Relevant to Claim No
A	US, A, 2820616 (NABAL) 21 January 1958, see claim and figures 1-3 -----	1

ANNEX TO THE INTERNATIONAL SEARCH REPORT
ON INTERNATIONAL PATENT APPLICATION NO.

PCT/US 88/02320
SA 23735

This annex lists the patent family members relating to the patent documents cited in the above-mentioned international search report. The members are as contained in the European Patent Office FDP file on 17/10/88. The European Patent Office is in no way liable for these particulars which are merely given for the purpose of information.

Patent document cited in search report	Publication date	Patent family member(s)	Publication date
EP-A- 0112994	11/07/84	US 4419716 JP 59142389	06/12/83 15/08/84
EP-A- 0057411	11/08/82	JP 57127790 US 4449579	09/08/82 05/22/84
DE-A- 3030136	11/03/82	None	
US-A- 2820616	21/01/58	None	
JP-A- 60-134450	17/07/85	None	

EPO FORM P0479

For more details about this annex : see Official Journal of the European Patent Office, No. 12/82