

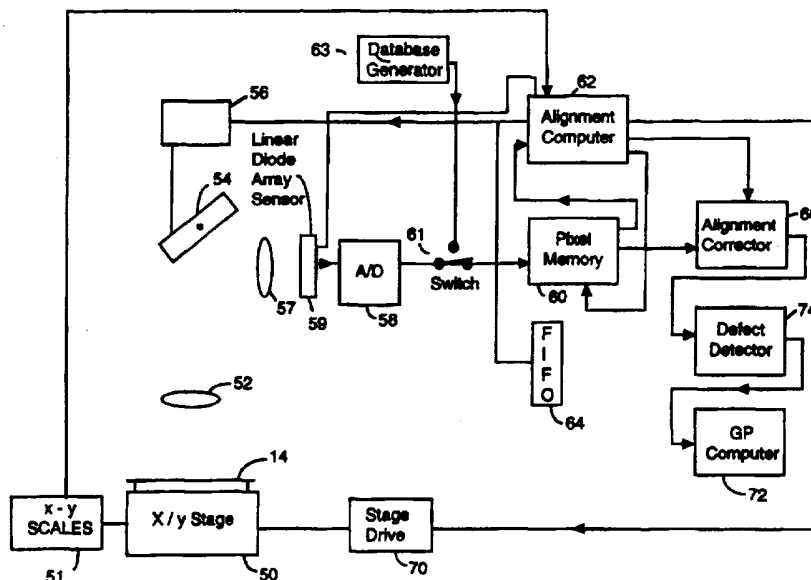

INTERNATIONAL APPLICATION PUBLISHED UNDER THE PATENT COOPERATION TREATY (PCT)

(51) International Patent Classification ⁶ : H04N 7/18, 9/47	A1	(11) International Publication Number: WO 97/13370 (43) International Publication Date: 10 April 1997 (10.04.97)
<p>(21) International Application Number: PCT/US96/15835</p> <p>(22) International Filing Date: 2 October 1996 (02.10.96)</p> <p>(30) Priority Data: 08/538,137 2 October 1995 (02.10.95) US</p> <p>(71) Applicant: KLA INSTRUMENTS CORPORATION [US/US]; 160 Rio Robles Street, San Jose, CA 95161-9055 (US).</p> <p>(72) Inventors: YOUNG, Scott; 4440 Prescott Road, Soquel, CA 95066 (US). KROEZE, Roger; 34723 Stearman Court, Tracy, CA 95376 (US). CHADWICK, Curt, H.; 220 Wooded View Drive, Los Gatos, CA 95023 (US). SZABO, Nicholas; 10235 Creston Drive, Cupertino, CA (US).</p> <p>(74) Agents: JONES, Allston, L. et al.; Peters, Verny, Jones & Bikša, Suite 6, 385 Sherman Avenue, Palo Alto, CA 94306-1840 (US).</p>	<p>(81) Designated States: European patent (AT, BE, CH, DE, DK, ES, FI, FR, GB, GR, IE, IT, LU, MC, NL, PT, SE).</p> <p>Published <i>With international search report.</i> <i>Before the expiration of the time limit for amending the claims and to be republished in the event of the receipt of amendments.</i></p>	

(54) Title: ALIGNMENT CORRECTION PRIOR TO IMAGE SAMPLING IN INSPECTION SYSTEMS



(57) Abstract

A method and apparatus, and variations of each, for inspecting a wafer (14) defining at least one die thereon, first obtains the electronic image (56) equivalent of two dies, and then determines the x and y offset (50) between those electronic images (60). Prior to inspection for defects (74), those two electronic images (60) are aligned (62) by adjusting the x and y positions (66) of one electronic image (56) of one die with respect to the electronic image (56) of the other die. Once that is accomplished, those electronic images (60) are compared to detect any defects (74) that may exist on one of the dies.

FOR THE PURPOSES OF INFORMATION ONLY

Codes used to identify States party to the PCT on the front pages of pamphlets publishing international applications under the PCT.

AM	Armenia	GB	United Kingdom	MW	Malawi
AT	Austria	GE	Georgia	MX	Mexico
AU	Australia	GN	Guinea	NE	Niger
BB	Barbados	GR	Greece	NL	Netherlands
BE	Belgium	HU	Hungary	NO	Norway
BF	Burkina Faso	IE	Ireland	NZ	New Zealand
BG	Bulgaria	IT	Italy	PL	Poland
BJ	Benin	JP	Japan	PT	Portugal
BR	Brazil	KE	Kenya	RO	Romania
BY	Belarus	KG	Kyrgystan	RU	Russian Federation
CA	Canada	KP	Democratic People's Republic of Korea	SD	Sudan
CF	Central African Republic	KR	Republic of Korea	SE	Sweden
CG	Congo	KZ	Kazakhstan	SG	Singapore
CH	Switzerland	LI	Liechtenstein	SI	Slovenia
CI	Côte d'Ivoire	LK	Sri Lanka	SK	Slovakia
CM	Cameroon	LR	Liberia	SN	Senegal
CN	China	LT	Lithuania	SZ	Swaziland
CS	Czechoslovakia	LU	Luxembourg	TD	Chad
CZ	Czech Republic	LV	Latvia	TG	Togo
DE	Germany	MC	Monaco	TJ	Tajikistan
DK	Denmark	MD	Republic of Moldova	TT	Trinidad and Tobago
EE	Estonia	MG	Madagascar	UA	Ukraine
ES	Spain	ML	Mali	UG	Uganda
FI	Finland	MN	Mongolia	US	United States of America
FR	France	MR	Mauritania	UZ	Uzbekistan
GA	Gabon			VN	Viet Nam

ALIGNMENT CORRECTION PRIOR TO IMAGE SAMPLING
IN INSPECTION SYSTEMS

5

Field of the Invention

The present invention is related to sub-pixel image alignment in wafer inspection machines, particularly to the alignment of images both prior to and subsequent to scanning. Two alternate methods are taught, one for laser scanning and the other for scanning with a linear array.

10

Background of the Invention

It is well known in the wafer inspection art that when two similar images are to be compared, sub-pixel alignment is often necessary to obtain the degree of accuracy that is desired. Traditionally that alignment was accomplished by digitally interpolating the image after scanning.

15

20

The most frequently used method for automatic inspection of photomasks or patterned semiconductor wafers utilizes comparison to detect defects. Typically, two supposedly identical patterns are compared by scanning and digitizing the images. The digitized images are then compared in high speed digital logic, or an image is compared with data stored in the CADs (Computer Aided Design System) database with data representing the desired pattern.

25

30

35

In the comparison process to detect differences between the two patterns some form of image subtraction is most frequently employed. However, image subtraction is contingent on sampling the two images (or the image and image data from the database) at nearly identical points for both images.

Early mask inspection systems, such as taught by Levy, et al., in U.S. Patent 4,247,203, were able to

guarantee only a $\pm 2\frac{1}{2}$ pixel registration accuracy between the two images. Because of the limited registration accuracy, Levy required that the defect detection algorithm use feature extraction, followed by the matching of these features, rather than image subtraction. Some time later Levy, U.S. Patent 4,579,455, taught area subtraction, but because of the limited registration accuracy computed the intensity difference at several possible registrations. If, for any of these registrations the absolute value of the intensities was less than a predetermined threshold, no defect was recorded at that particular pixel. Subsequently, Specht, et al., in U.S. Patent 4,805,123, taught a method of achieving image subtraction by first reducing the registration error between the two images to less than a pixel. However, the Specht method had the shortcoming that in re-registering (also known as resampling) the two images with respect to each other, interpolation of the scanned image was used, which in turn introduced errors in determining the intensities of the resulting pixels. These errors limited sensitivity (the smallest detectable defect).

As will be shown subsequently, the maximum intensity error determines the maximum detectable defect-to-pixel ratio. Since inspection speed, at a given sensitivity, defines the productivity of an inspection system, for a fixed sampling rate, it is desirable to maximize the pixel size. Therefore, to achieve the maximum throughput, one must minimize the registration error. The present invention teaches methods for minimizing the registration error for the two most common scanning methods: scanning with a laser and scanning with a linear array.

35 Summary of the Invention

The present invention is a method and apparatus, and variations of each, for inspecting a wafer

defining at least one die thereon. The present invention first obtains the electronic image equivalent of two die, and then determines the x and y offset between those electronic images. Prior to inspection for defects, those two electronic images are aligned by adjusting the x and y positions of one electronic image of one die with respect to the electronic image of the other die. Once that is accomplished, the those electronic images are compared to detect any defects that may exist on one of the die.

Brief Description of the Figures

Figure 1 illustrates the pixelization of a surface by an inspection system and the mis-alignment between two images.

Figure 2 is a block diagram of a diode array scanning system embodiment of the present invention.

Figure 2a is the transparent reticle version of the system of Figure 2.

Figure 3a illustrates the scanning of multiple patterns from die-to-die inspection.

Figure 3b illustrates the scanning of a single pattern for die-to-database inspection.

Figure 4 is a block diagram of a laser scanning system embodiment of the present invention.

Figure 4a is the transparent reticle version of the system of Figure 4.

Figure 5 is a sketch of a signal that is representative of the signal applied to the acousto-optic deflector/driver of Figure 4 to correct for coarse x-direction mis-alignment of the wafer of the stage.

Detailed Description of the Present Invention

The key to the present invention is the use of the same sampling points for both images, or the image of the die being viewed and the die equivalent in the data base, to be compared as will be seen from the following

discussion.

Figures 3a and 3b illustrate the typical serpentine scanning technique for multiple patterns and for a single pattern, respectively. In Figure 3a wafer 14 is scanned in a serpentine path 31, sweeping out several dies 33, 35 and 37 in die-to-die inspection, and in Figure 3b only a single die is scanned in serpentine path 31' when die-to-database inspection is employed. Each sweep of the path is designated a swath. A typical swath may have a height of 500 to 2,000 pixels and may have a length of 500,000 pixels.

Figure 1 illustrates two identical forms 20 and 30 superimposed on a grid that represents the boundaries of pixels 10 as defined by the inspection system of the present invention. The nominal sampling point of each pixel is the center of that pixel however in reality the scanner measures the total light energy that falls on an area of approximately the size of a pixel 10. The idealized intensity value of each pixel is the normalized intensity value expressed as a percentage of the maximum. Figure 1 shows two identical geometric forms 20 and 30, each consisting of a rectangle of opaque material (e.g., chromium) on a transparent medium, such as quartz. In this configuration, pixels 40A and 40B have different measured values since the sampling points (the centers of the pixels) are not equidistant from the corresponding one of two forms 20 and 30, respectively. Consequently, pixels 40A and 40B, as shown in Figure 1 have measurable values of 76% and 92%, respectively.

Clearly, if pixel-to-pixel comparison is used for defect detection, the sampling points must nearly coincide with respect to the forms. It can readily be seen that the registration error (the relative displacement of the sampling points between the two forms 20 and 30) determines the maximum possible intensity difference between any two pixels to be compared. Assuming that ΔI is the maximum possible intensity

difference attributable to the registration error, then the defect detectors intensity threshold must be at least ΔI . For binary images, i.e. where at every sampling point the transmittance is either 0 or 100%, the minimum detectable defect size (in terms of area) is merely D_x times D_y , where D_x and D_y are the maximum x and y directional registration errors (see Figure 1 for the D_x and D_y between forms 20 and 30 for example).

In the prior art, as stated above in the Background of the Invention section, registering the two images was accomplished by first scanning both images. Next, integer pixel misalignment was corrected as taught by Levy, by shifting the image in the digital memory the appropriate number of locations. Fractional pixel registration was achieved by resampling one of the images as taught by Specht.

In the present invention, for both scanning techniques, a coarse correction is made prior to sampling, the image is scanned and then stored in memory. For diode array scanning (Figure 2) coarse correction in the X-direction is implemented by a mechanical movement of a mirror, while for laser scanning (Figure 4) X-directional coarse correction uses timing control of the sampling. In the Y-direction, both scanning techniques use timing control of the sampling.

The purpose of the present invention is to minimize the intensity error caused by the registration error of sampling points with respect to the two forms to be compared whether die-to-die or die-to-data base.

The present invention is an improvement over the Specht method in that a coarse correction of the misregistration error is achieved in both X and Y prior to the scanning of the pattern, or patterns. The residual error after coarse correction and subsequent to scanning is then further reduced by interpolation of the intensities. Since the residual alignment error after coarse correction is now small, the error contributed by

interpolation is significantly smaller than when the Specht alignment and inspection method is used. Hence, with the present invention, the two images used in image subtraction are much better aligned with respect to each other and consequently the minimum detectable defect, as a percentage of the pixel size, is significantly smaller than as in the prior art. Consequently, a larger pixel size can be used for a given minimum detectable defect. A larger pixel size, for a given minimum detectable defect and for a constant pixel rate translates into a higher throughput than in the prior art. Higher throughput produces more defect data which in turn results in more reliable diagnosis of the problems and better yield management.

One significant concept of the present invention is that one may employ a pixel that is significantly larger than the minimum detectable defect or even the minimum feature size (geometric figure on the mask or wafer), provided the two images are registered accurately with respect to each other.

The present invention relates to two different scanning embodiments and how improved registration may be achieved using the present invention. These scanning embodiments are: Scanning with a Diode (or TDI) Array, and Scanning with a Laser Beam. These two embodiments are discussed separately below. Additionally, it should be kept in mind that both embodiments lend themselves to scanning with both transmitted and reflected light, either separately or together in the same system.

Diode (or TDI) Array Scanning

Figure 2 is a block diagram of a diode (or TDI) array scanning system using reflected light. A wafer, or reticle, 14 is mounted on X/Y stage 50, with X-Y scales 51 mounted thereon to determine stage position, and an illuminator (not shown) illuminates the area of wafer 14 under objective lens 52. The light reflected from wafer

14 travels through objective lens 52, is reflected by tilted mirror 54 to lens 57 through which a portion of the wafer image is projected onto linear diode array 59. Mirror 54 shifts the image of wafer 14 onto diode array 59 by pivoting about an axis perpendicular to the plane of the paper under the control of piezo-electric actuator 56 with the shift occurring in the y-direction. Each time stage 14 travels the distance of a pixel, array 59 serially reads out a (y-directional) column of intensities which are digitized by A/D converter 58. This information flows from converter 58 into each of pixel memory 60, first-in-first-out (FIFO) memory 64 and alignment computer 62. Pixel memory 60 is a two-dimensional memory of the width of a swath and a length somewhat greater than the widest (x-directional dimension) die to be inspected. Pixel memory 60 is essentially also a FIFO memory, i.e. its input accepts a column of pixels at a time and outputs them at the other end. Pixel memory 60 has output registers which are capable of shifting one pixel, on a command from alignment computer 62, the data in either the x or y direction, prior to producing an output, similar to the method taught by U.S. Patent 4,247,203 by Levy et al. The purpose of pixel memory 60 is to store pixel data from one die while the next die is being scanned so that the two dies can be compared.

This operation is illustrated by the following example. Referring to Figures 2 and 3a as die 33 is scanned on the first pass across wafer 14, the information flows into pixel memory 60. Then, as the scanner starts to scan die 35, the information from die 33 is read from pixel memory 60 correctly aligned to the closest integer pixel to the image of die 35. Alignment computer 62 performs running alignment computation to determine the misalignment between the two data streams corresponding to the first swath across die 33 and the present time swath across die 35. The alignment error of

these two data streams is computed as described by Specht. Integer alignment errors are corrected by the output registers of pixel memory 60, while the fractional error is corrected by alignment corrector 66 by using
5 resampling as discussed below.

Overall, the two data streams, one from FIFO memory 64 and the other from alignment corrector 66, arrive at defect detector 74 aligned with a precision of such as 1/256 of a pixel is achievable.

10 In addition to the alignment correction commands fed to alignment corrector 66 and pixel memory 60, alignment computer 62 produces three other signals. Two of these, one to stage drive 70 and a second to tilt mirror actuator 56, are intended to provide low frequency
15 alignment correction signals. The signal to tilt mirror actuator 56 provides y-directional control, while the signal to stage drive 70 exercises control in the x-direction. The purpose of these is to make sure that the misalignment between die does not exceed the dynamic
20 range that the correction system can rectify. Alignment computer 62 also produces a strobe signal to initiate the readout of a column of pixels from linear diode sensor 59. Since stage 50 travels approximately at a constant speed, slightly varying the time between strobe pulses
25 allows fine alignment in the x-direction. The strobe is generated in alignment computer 62 by a phase-locked loop which derives its input from the x-directional alignment error and from a linear scale mounted on stage 50 that measures the position of stage 50 by alignment
30 computer 62. U.S. Patent 4,926,489 by Danielson, et al., describes a similar implementation using a phase-locked loop.

FIFO memory 64 is a short memory of the same width as the swath height. Its purpose is to delay the
35 flow of pixel information into defect detector 74 sufficiently to make sure that alignment computer 62 has enough image data to correct the alignment error, prior

to the two image data streams reach defect detector 74.

In defect detector 74 the corresponding intensity values of the two images are compared and if the absolute value of the difference exceeds a
5 predetermined threshold, an error flag is raised. The error data is then sent to general purpose computer 72 (e.g. a Sun workstation), where adjacent defect locations are combined to permit a determination of the size and shape of the defects. This information is then used by
10 yield management programs.

The basic philosophy behind this embodiment of the present invention is that tilting mirror 54 and proper strobing of linear diode sensor 59 provide first order alignment corrections which reduce the needed
15 dynamic range for the fine correction. Since the amount of error contributed by the resampling is a function of the dynamic range of the correction needed, the error intensity into defect detector 74 is smaller than would be achievable without correcting the alignment prior to
20 sampling the image.

In the case where the comparison is die-to-data base, data is obtained from a die 14 on stage 50 with switch 61 in the position shown, then switch 61 is
25 switched to the other position and data from data base generator 63 is connected to supply the second data set. The overall operation is therefore the same as described above.

The subject invention may also be used to inspect transparent substrates, such as a reticle.
30 Figure 2a illustrates the system in that case. Substrate 14', a reticle, is illuminated from below and the only difference between this implementation and the one that uses transmitted light, is the location of the source of the illumination.

35 When the reticles, rather than wafers, are inspected, ordinarily the inspection is a comparison with the data base. The data base generator, at its output,

produces a data stream that simulates the desired optical image. Switch 61 allows either the datastream from A/D converter 58 or from database generator 63 to flow into pixel memory 60.

5

Laser Scanning

The same general approach taught above with respect to Figure 2 may also be used with laser scanning. The laser scanner here can be adapted from the
10 implementation of the KLA 301 Reticle and Mask Inspection Unit, made by the assignee. Figure 4 illustrates such a laser scanner embodiment of the present invention. Laser 80 directs coherent light to acousto-optic deflector/driver 82 which deflects the light in the
15 y-direction, as described by Evelet in U.S. Patent 3,851,951 (High Resolution Laser Beam Recorder with Self-focusing Acousto-optic Scanner). The y-deflected light beam from acousto-optic deflector/driver 82 is then applied to beamsplitter 84 through which the laser beam
20 passes and proceeds to lens 86 which focuses the laser beam on wafer 14 on X/Y stage 50. Some of the light incident on wafer 14 is then reflected back into lens 86 and proceeds to beamsplitter 84, where portions of the reflected light are reflected to condenser lens 88 where
25 it is refracted and collected on the surface of single diode sensor 90. The resultant electrical signal from diode 90 is then applied to A/D converter 100. The remaining components of the laser implementation, with the exception of alignment computer 62', function as for
30 the diode array implementation of Figure 2. Consequently, pixel memory 60, alignment corrector 66, FIFO 64, defect detector 74, general purpose computer 72, stage drive 70 and X/Y stage 50 function as described above for the diode array implementation shown in Figure
35 2 with stage 14 executing the same serpentine scanning travel as described previously with respect to Figure 3.

In addition to the functions outlined above,

A/D converter 100 and alignment computer 62' perform additional functions that are necessary to control the operation of acousto-optic deflector/driver 82. Acousto-optic deflector/driver 82 is driven by a saw tooth signal (see Figure 5) generated by alignment computer 62'. That saw tooth signal includes two components, a ramp 92 and variable time delay 96 between consecutive ramps. X-directional coarse correction is implemented by varying time-delay 96 between successive ramps 92, since the stage travels at a constant speed. The timing of the start of ramp 92 is controlled by a phased-locked loop oscillator of alignment computer 62' that derives its control signal from the x-directional alignment error determined by alignment computer 62'. Alignment computer 62' also generates strobe pulses to control when A/D converter 100 samples the video signal from diode sensor 90. Since the laser beam sweeps across wafer 14 at a constant speed, the y-coordinates of the samples are determined by the timing of the strobe pulses. These strobe pulses are also driven by the phase-locked loop oscillator of alignment computer 62' which is controlled by the y-directional alignment error. The fine corrections in both X and Y are executed in alignment corrector 66, as discussed for the diode array embodiment of Figure 2.

Also, for the die-to-data base situation. the use of switch 61 and data base generator 63 is as discussed above for Figure 2.

For the laser scanner implementation using transmitted light as in Figure 4a, reticle 14' is placed on stage 50 and the implementation is virtually identical to the one shown in Figure 4 except that diode detector 90 is now under stage 50 to collect, via condenser lens 88', the light transmitted through reticle 14'. In most instances, the inspection will be against the CADs database for which DataBase Generator 63 provides a simulated image.

While the forgoing techniques are most beneficial in defect detection where image subtraction is used, all known techniques, such as those using feature extraction and comparison, specifically, operate more efficiently when registration errors are minimized. Of course, these methods may also be used when a single image is derived physically and is compared with computer generated data. Furthermore, these alignment techniques are useful in all image processing applications that depend on alignment.

While the present invention has been described in several embodiments and with exemplary routines and apparatus, it is contemplated that persons skilled in the art, upon reading the preceding descriptions and studying the drawings, will realize various alternative approaches to the implementation of the present invention. It is therefore intended that the following appended claims be interpreted as including all such alterations and modifications that fall within the true spirit and scope to the present invention and the appended claims.

What is Claimed is:

1. A method for inspecting a wafer defining at least one die thereon, said method comprising the steps of:
 - 5 a. obtaining the electronic image equivalent of two die;
 - b. determining the x and y offset between the electronic images of said two die of step a.;
 - c. aligning said electronic images of said
10 two die by adjusting the x and y positions of one electronic image of one die with respect to said electronic image of said other die;
 - d. comparing said electronic images from step
c.;
 - 15 e. identifying image differences between the two die compared in step d.

2. An apparatus to inspect a wafer defining at least one die thereon comprising:
 - 20 an x-y stage to transport said die;
 - a scanner to obtain an electronic image equivalent of said at least one die as said x-y stage transports said die;
 - a first comparator coupled to said scanner to
25 determine the x and y offset between the electronic images of two die;
 - an alignment computer to reposition said scanner to adjust the x and y positions of one electronic image of one die with respect to said electronic image of
30 said other die;
 - a second comparator coupled to said scanner to compare said electronic images of said first and second die following the operation of said alignment computer; and
 - 35 a defect detector coupled to said second comparator to identify defect differences between said electronic images compared by said second comparator.

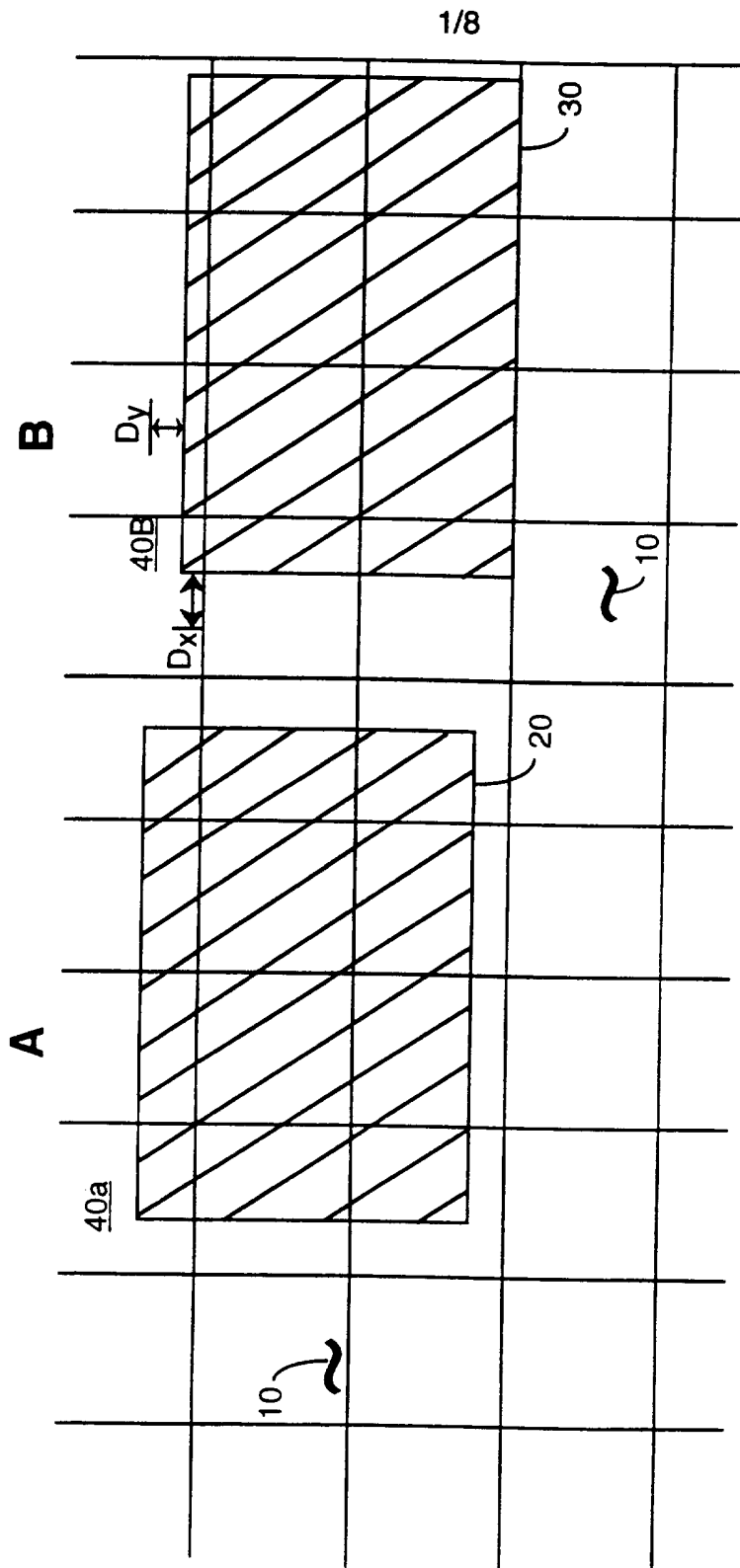

Figure 1

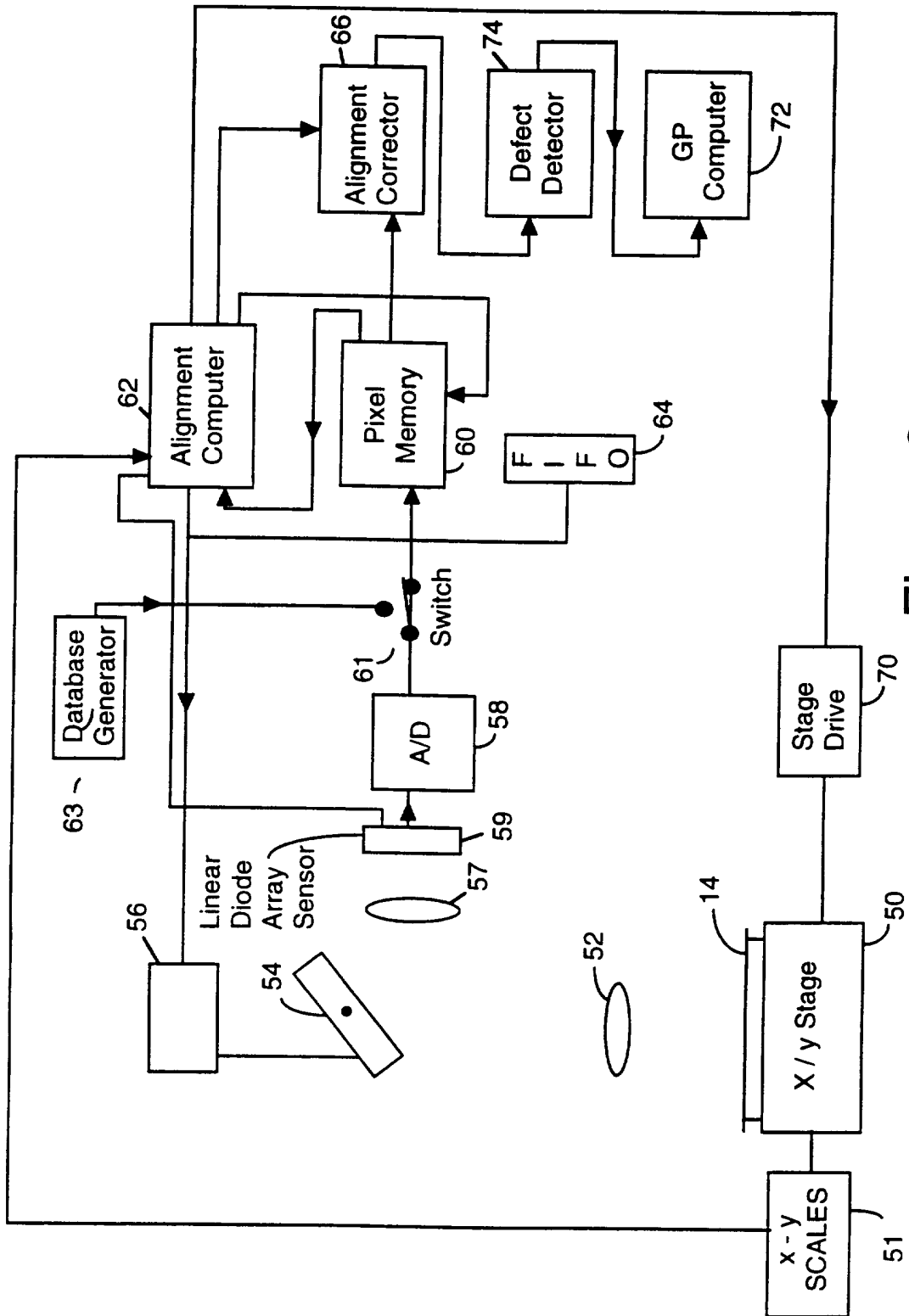

Figure 2

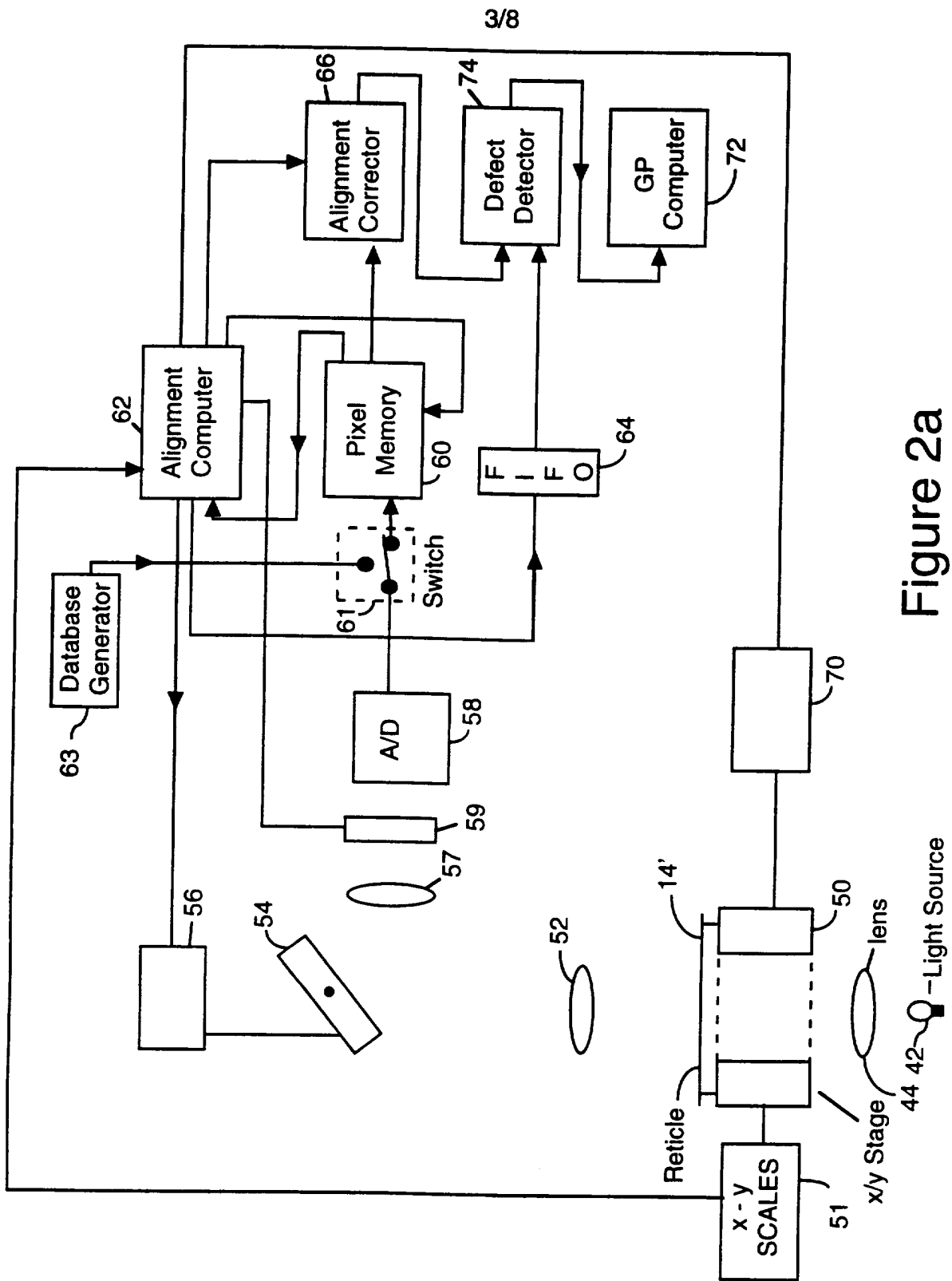

Figure 2a

4/8

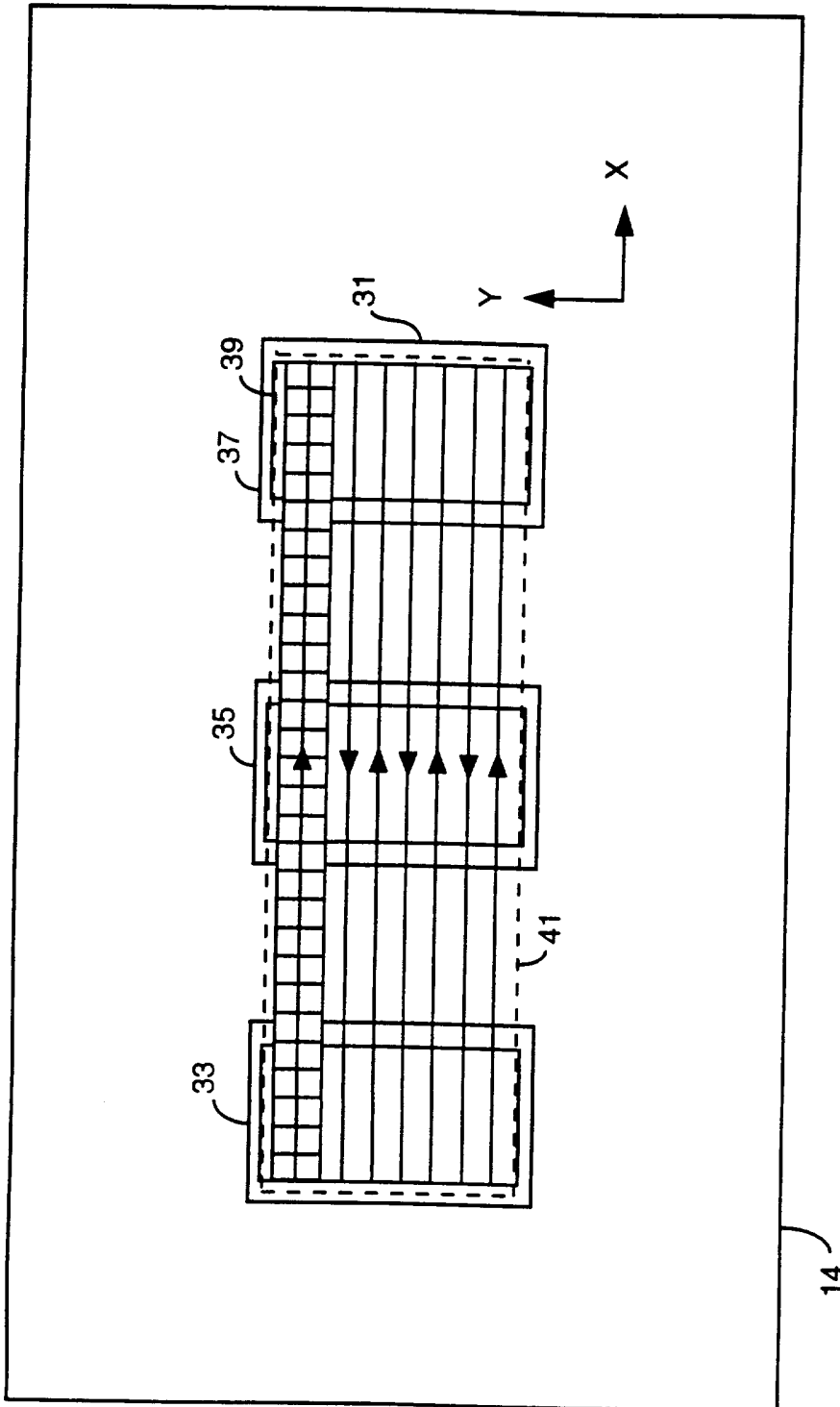

Figure 3a

5/8

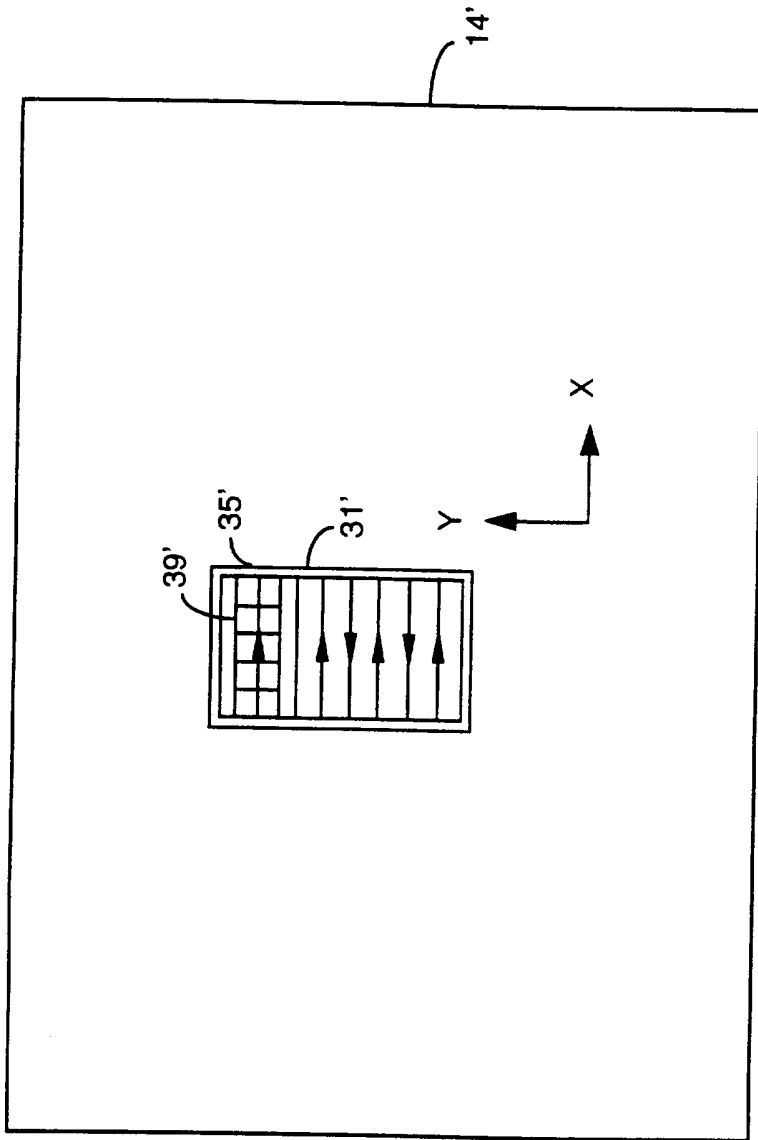

Figure 3b

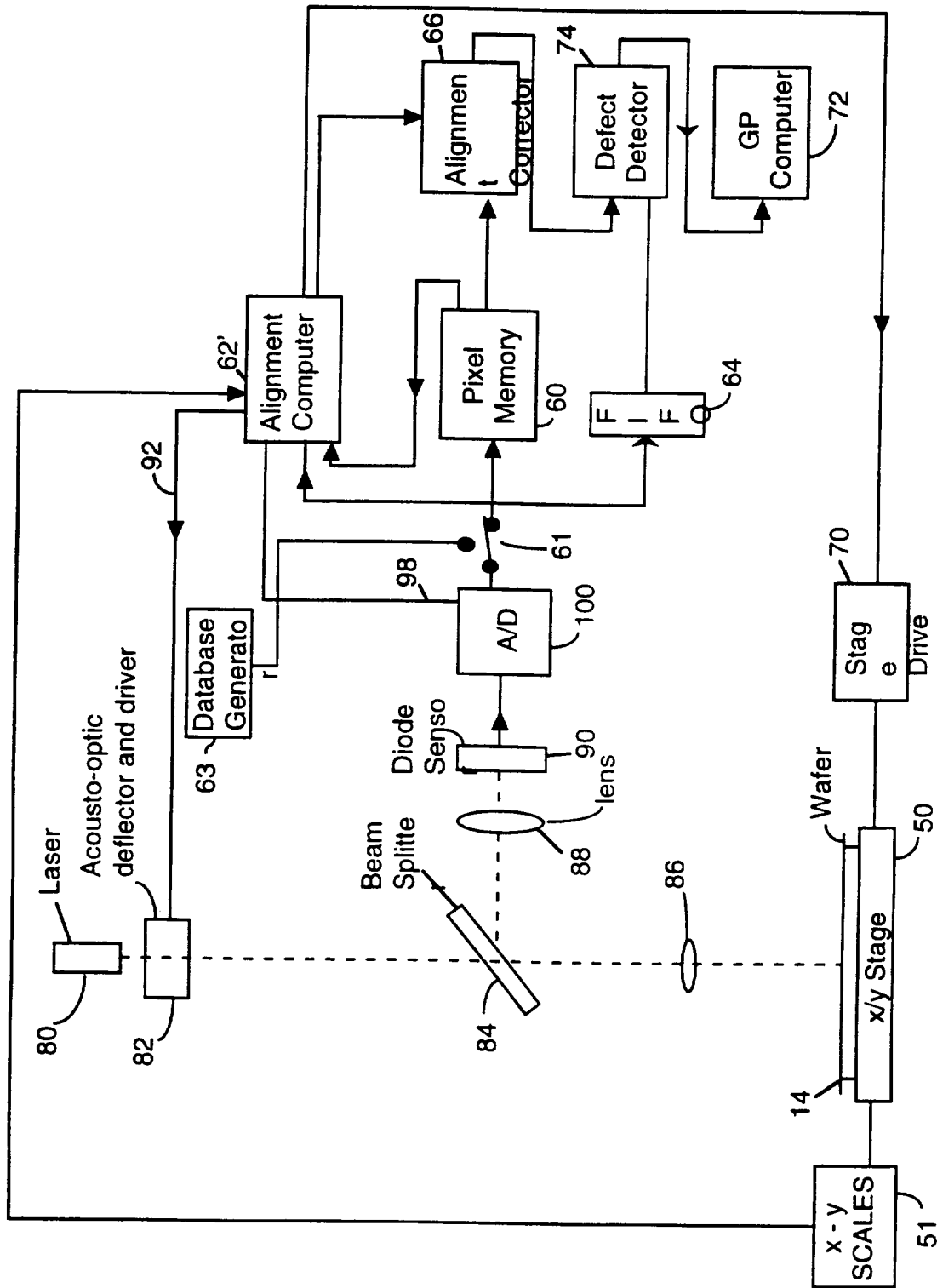

Figure 4

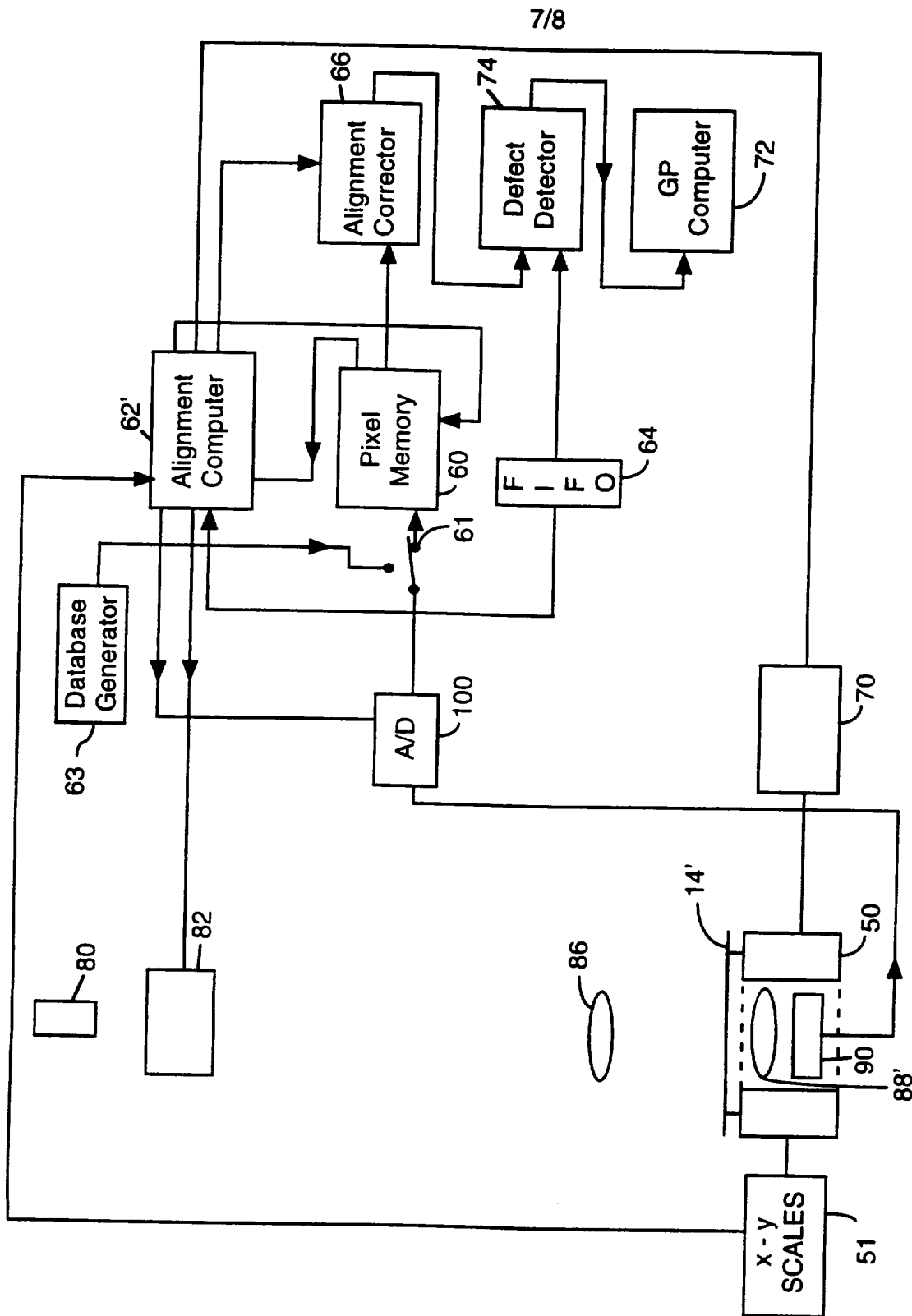

Figure 4a

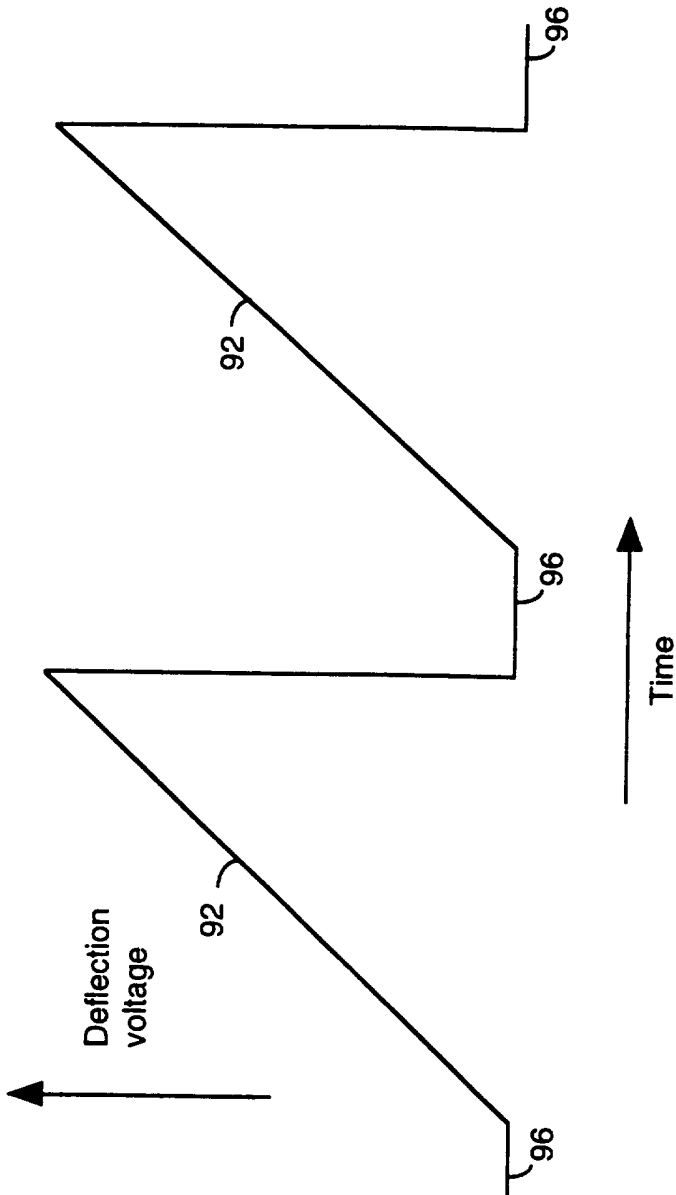

Figure 5

INTERNATIONAL SEARCH REPORT

International application No.
PCT/US96/15835

A. CLASSIFICATION OF SUBJECT MATTER

IPC(6) :H04N 7/18, 9/47
US CL :348/95

According to International Patent Classification (IPC) or to both national classification and IPC

B. FIELDS SEARCHED

Minimum documentation searched (classification system followed by classification symbols)

U.S. : 348/95, 87, 61, 86, 88, 92, 94, 125, 126, 127, 128, 129, 130
IPC(6): H04N 7/18, 9/47

Documentation searched other than minimum documentation to the extent that such documents are included in the fields searched

Electronic data base consulted during the international search (name of data base and, where practicable, search terms used)

APS, DIALOG

C. DOCUMENTS CONSIDERED TO BE RELEVANT

Category*	Citation of document, with indication, where appropriate, of the relevant passages	Relevant to claim No.
X	US, 4,644,172 A (SANDLAND ET AL) 17 FEBRUARY 1987, FIGS. 1, 2, AND 18.	1 and 2
Y	US, 4,618,938 A (SANDLAND ET AL) 21 OCTOBER 1986.	1 and 2
X, E	US, 5,572,598 A (WIHL ET AL) 05 NOVEMBER 1996.	1 and 2
Y, E	US, 5,578,821 A (MEISBERGER ET AL) 26 NOVEMBER 1996.	1 and 2
Y, E	US, 5,563,702 A (EMERY ET AL) 08 OCTOBER 1996.	1 and 2
Y, P	US, 5,502,306 A (MEISBURGER ET AL) 26 MARCH 1996.	1 and 2

Further documents are listed in the continuation of Box C. See patent family annex.

* Special categories of cited documents:	*T* later document published after the international filing date or priority date and not in conflict with the application but cited to understand the principle or theory underlying the invention
A document defining the general state of the art which is not considered to be of particular relevance	*X* document of particular relevance; the claimed invention cannot be considered novel or cannot be considered to involve an inventive step when the document is taken alone
E earlier document published on or after the international filing date	*Y* document of particular relevance; the claimed invention cannot be considered to involve an inventive step when the document is combined with one or more other such documents, such combination being obvious to a person skilled in the art
L document which may throw doubts on priority claim(s) or which is cited to establish the publication date of another citation or other special reason (as specified)	*G* document member of the same patent family
O document referring to an oral disclosure, use, exhibition or other means	
P document published prior to the international filing date but later than the priority date claimed	

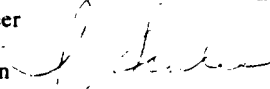
Date of the actual completion of the international search 26 DECEMBER 1996	Date of mailing of the international search report 31 JAN 1997
Name and mailing address of the ISA/US Commissioner of Patents and Trademarks Box PCT Washington, D.C. 20231 Facsimile No. (703) 305-3230	Authorized officer Tommy Chin  Telephone No. (703) 305-4715