



US 20100019609A1

(19) **United States**
(12) **Patent Application Publication**
Stout et al.

(10) **Pub. No.: US 2010/0019609 A1**
(43) **Pub. Date: Jan. 28, 2010**

(54) **END TURN CONFIGURATION OF AN ELECTRIC MACHINE**

Publication Classification

(76) Inventors: **John Stout**, Long Beach, CA (US);
Daniel M. Saban, Corona, CA (US); **Paulo Guedes-Pinto**, Brea, CA (US)

(51) **Int. Cl.**
H02K 1/16 (2006.01)
H02K 15/08 (2006.01)
H02K 3/48 (2006.01)
(52) **U.S. Cl. 310/198; 29/596; 310/208; 310/260**

Correspondence Address:
FISH & RICHARDSON P.C.
P.O. BOX 1022
MINNEAPOLIS, MN 55440-1022 (US)

(57) **ABSTRACT**

A stator for an electric machine includes multiple conductive coils. Each coil defines a loop that extends axially through the elongate core, exits the core through an end face, and reenters the core through the end face. A first subset of the coils collectively form a first radial layer axially exterior the core and a third radial layer axially exterior the core. Each coil in the first subset resides in both the first layer and the third layer. A second subset of the coils collectively forms a second radial layer axially exterior the core and a fourth radial layer axially exterior the core. Each coil in the second subset residing in both the second layer and the fourth layer.

(21) Appl. No.: **12/496,488**
(22) Filed: **Jul. 1, 2009**

Related U.S. Application Data

(60) Provisional application No. 61/084,238, filed on Jul. 28, 2008, provisional application No. 61/096,290, filed on Sep. 11, 2008.

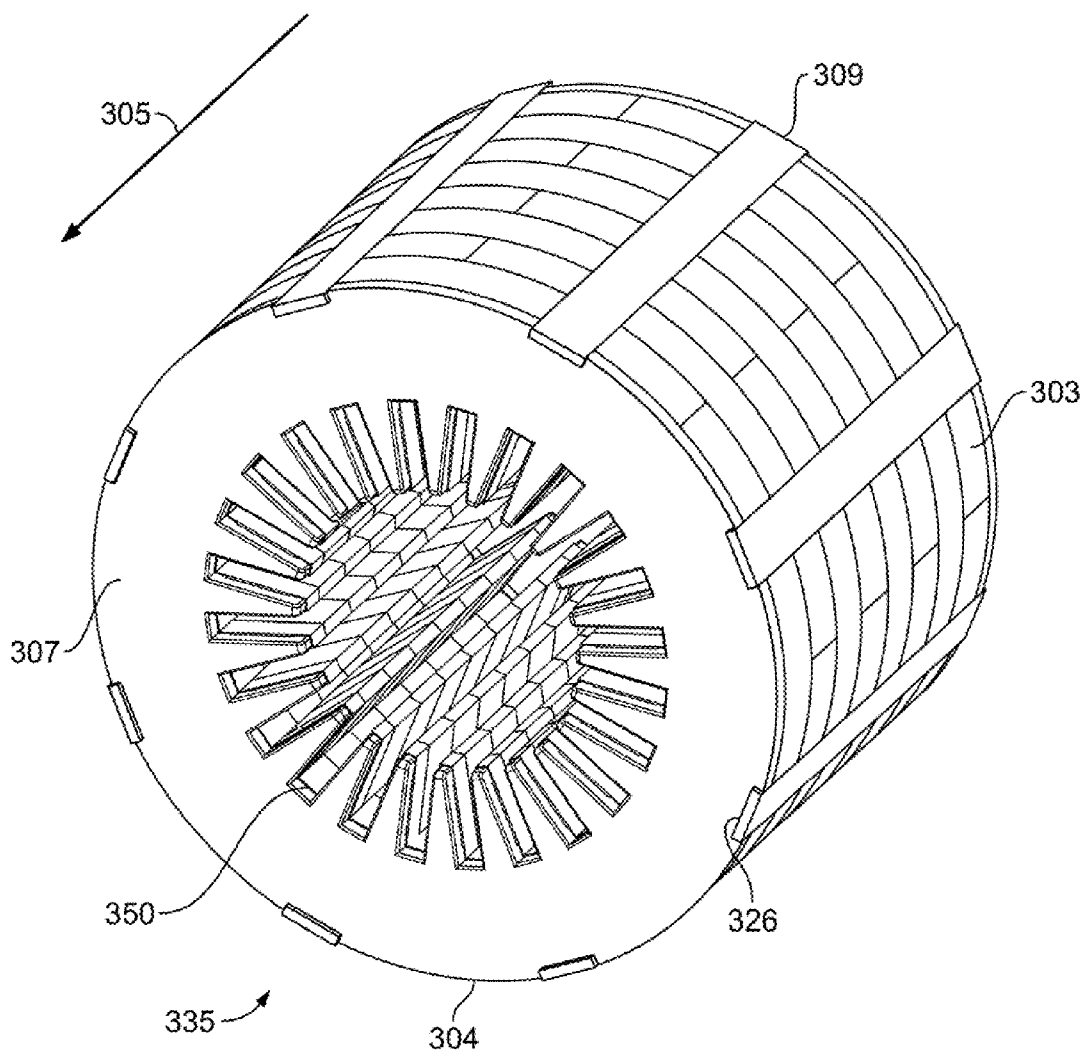

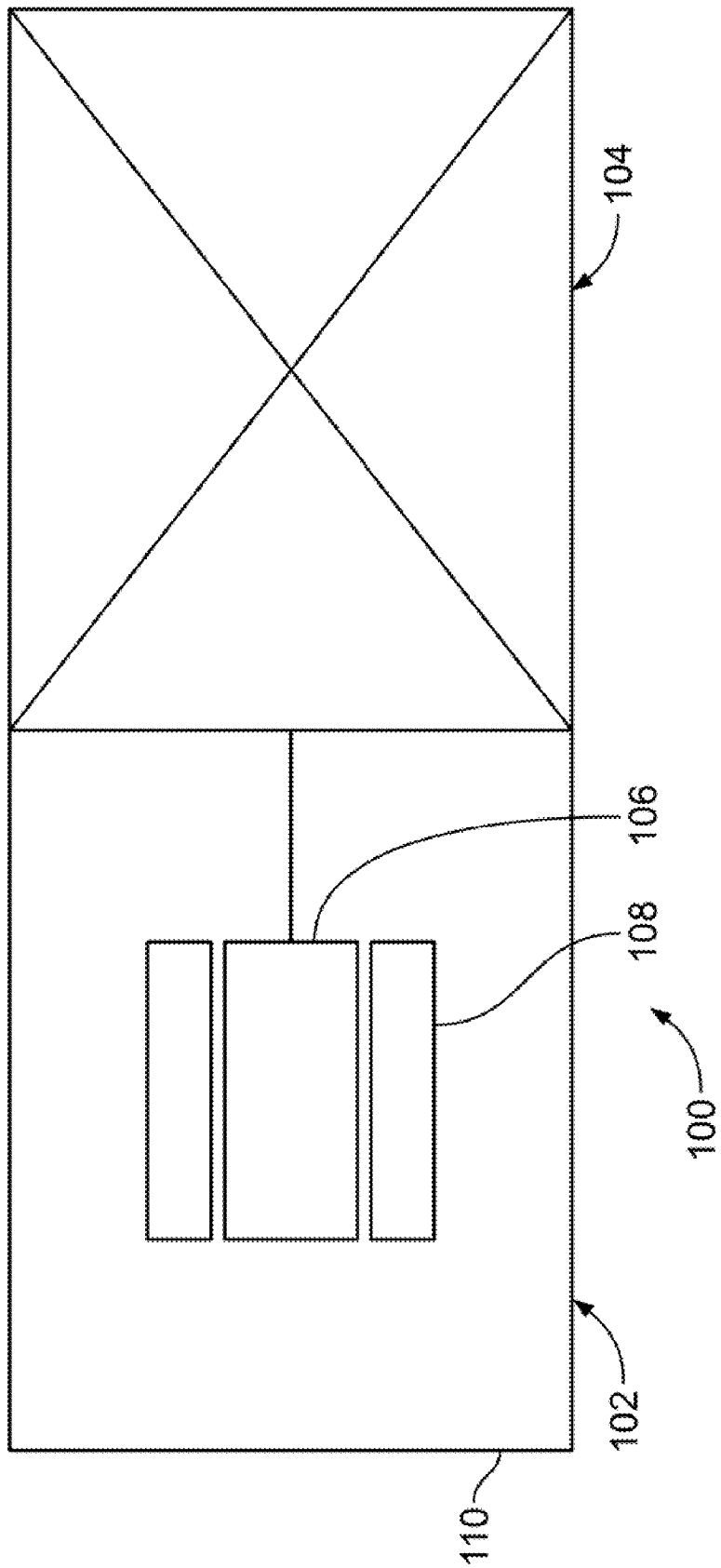
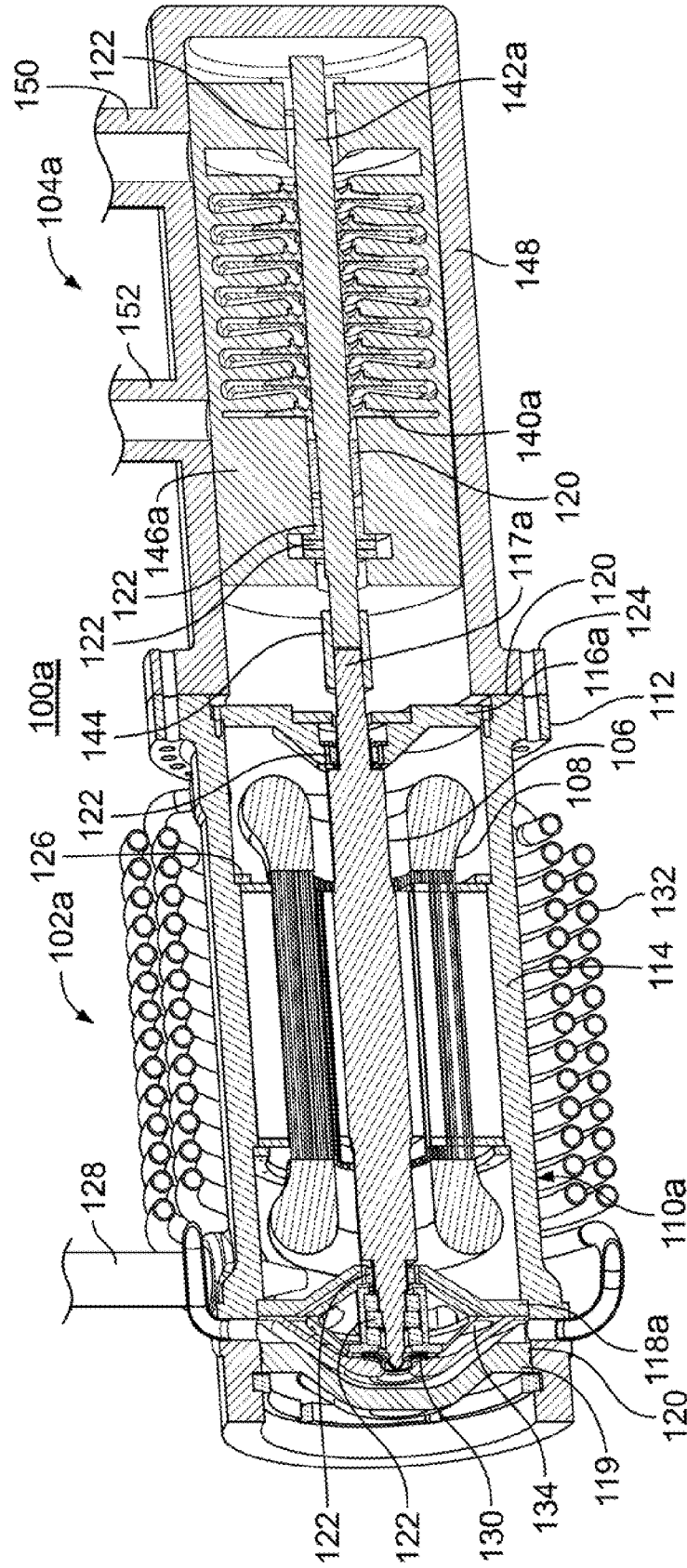

FIG. 1A



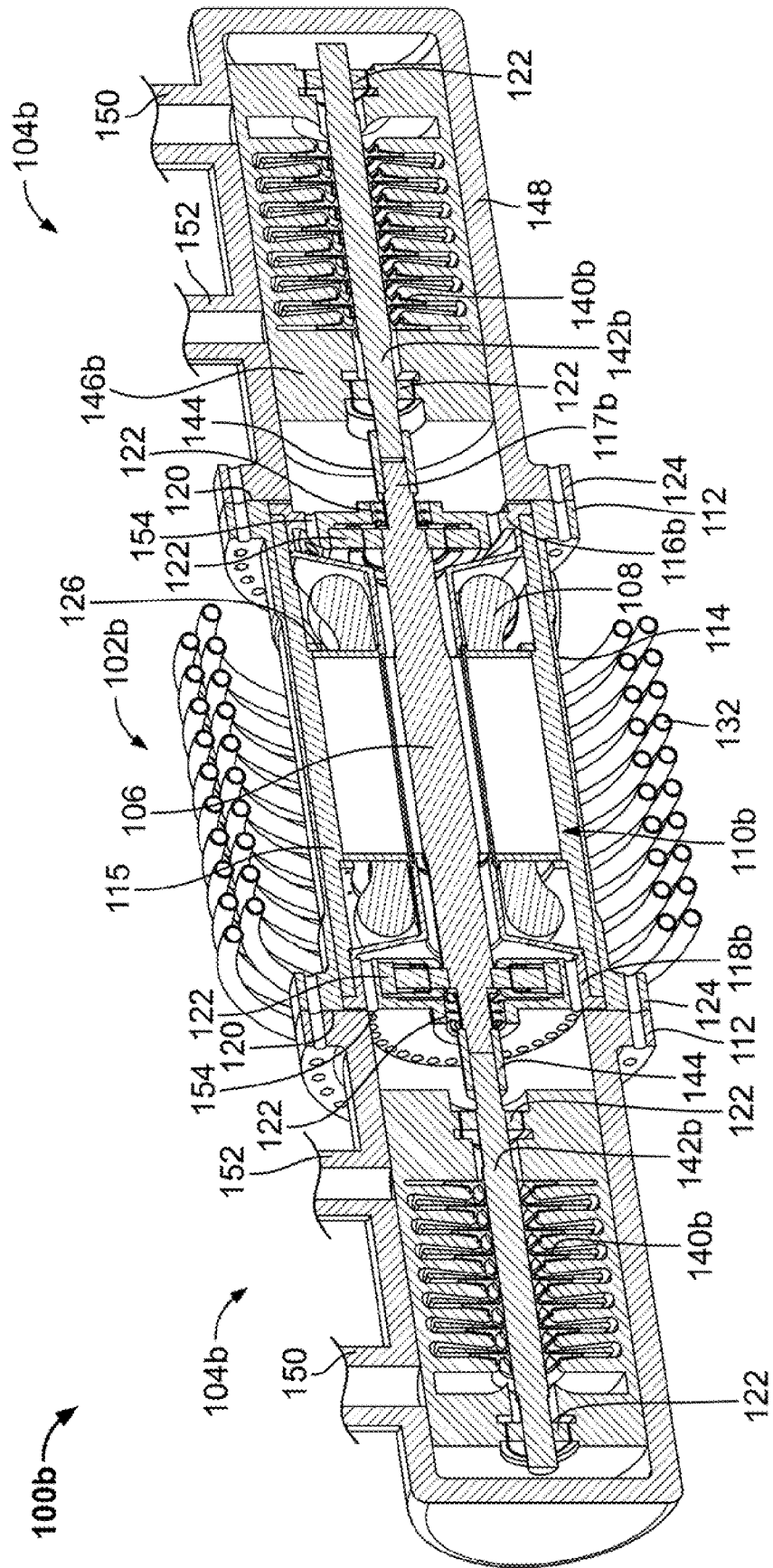

FIG. 1C

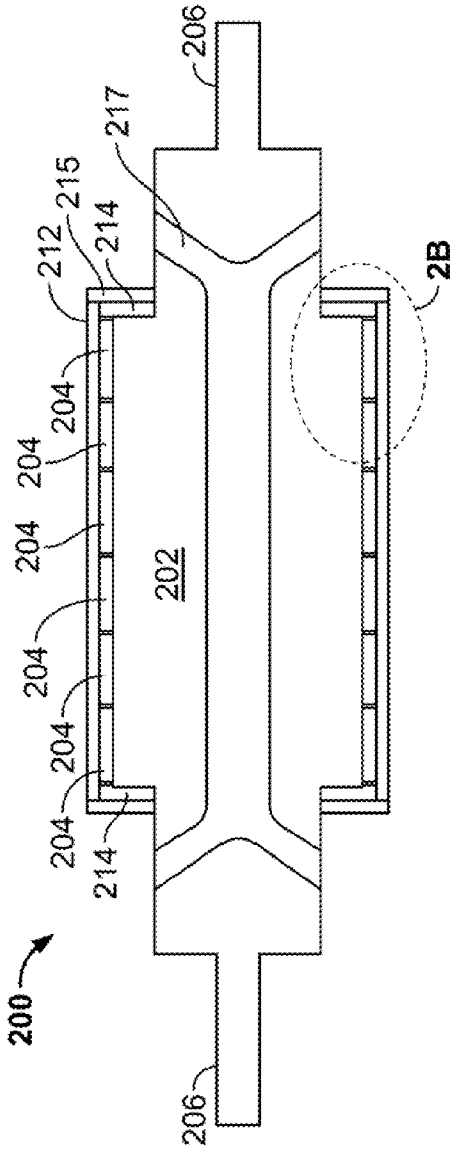

FIG. 2A

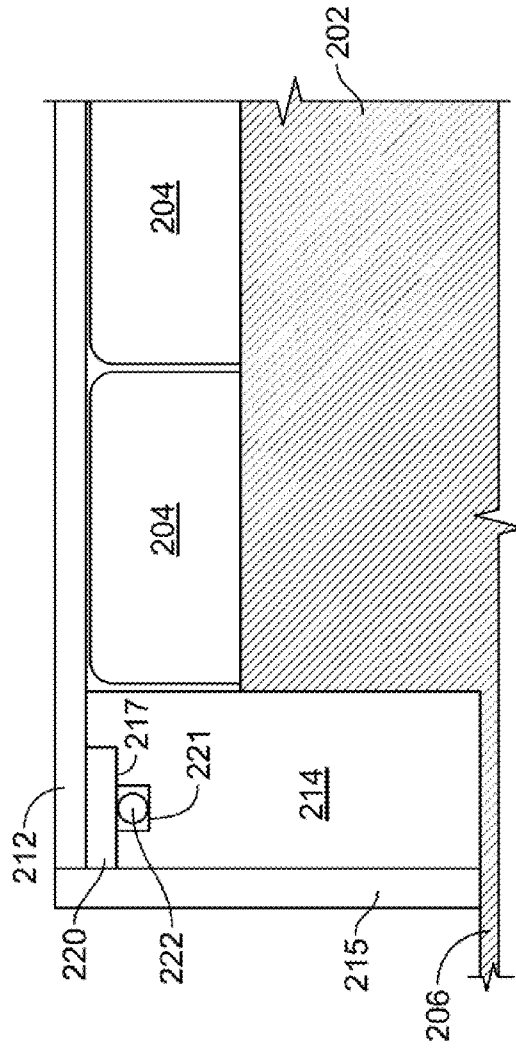

FIG. 2B

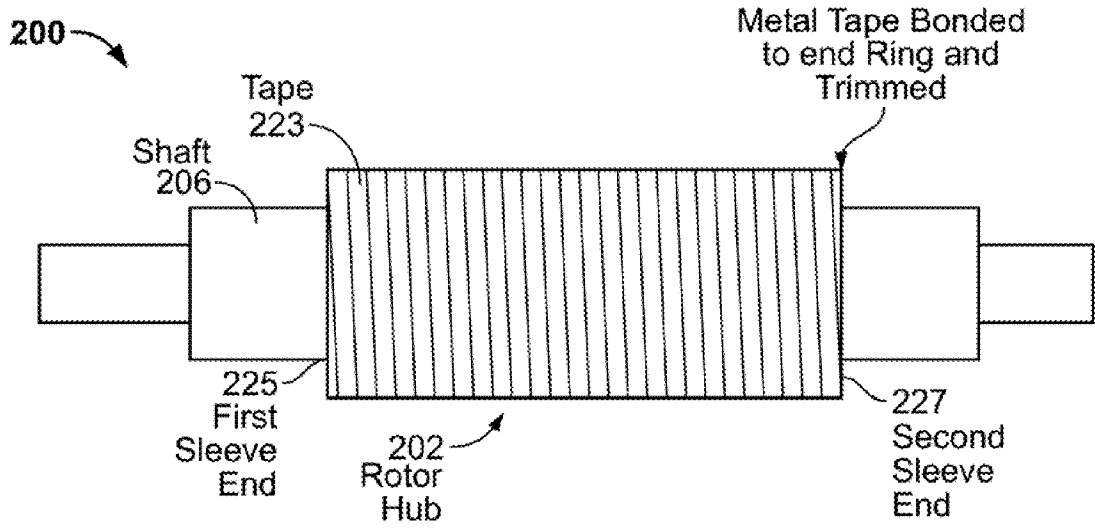

FIG. 2C

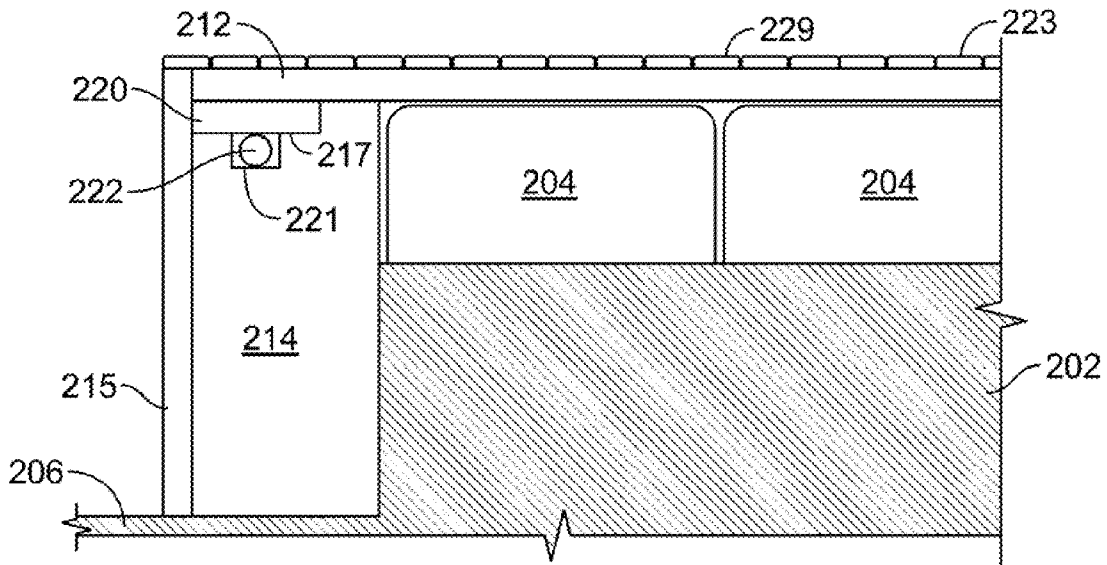

FIG. 2D

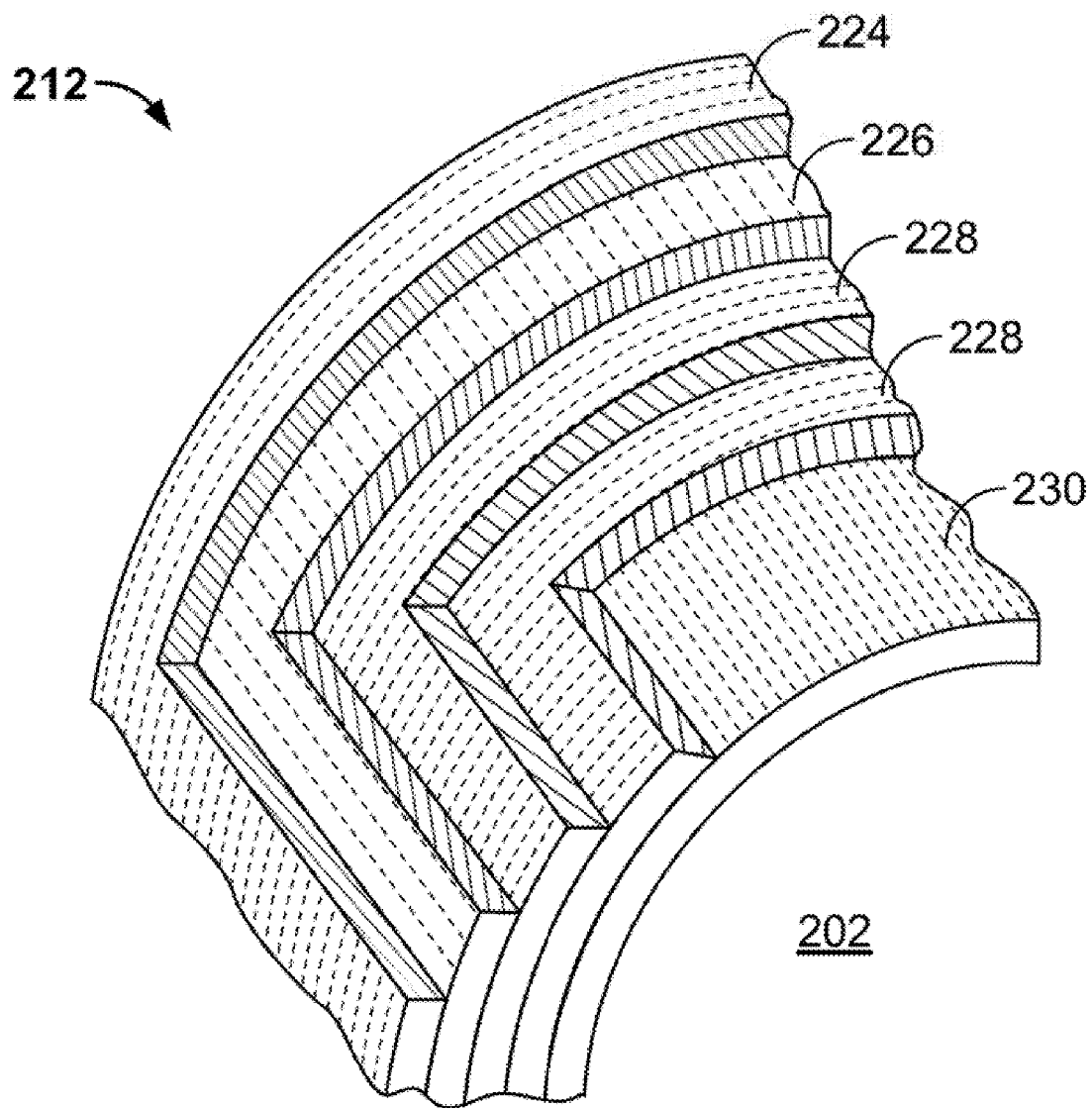

FIG. 2E

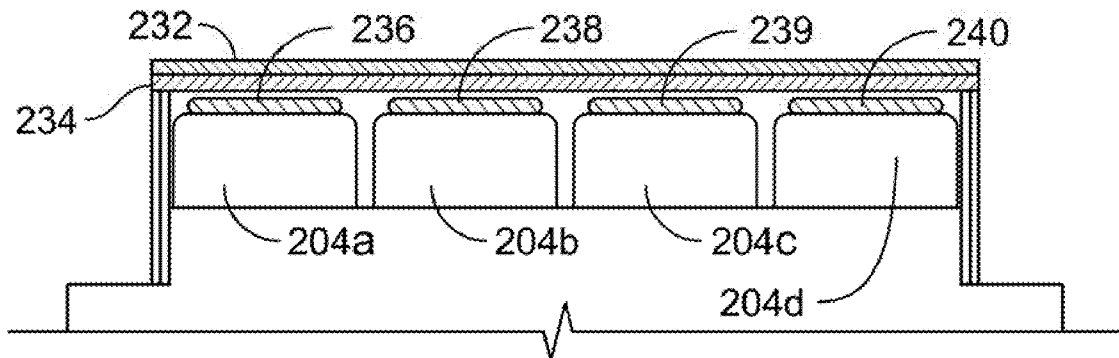

FIG. 2F

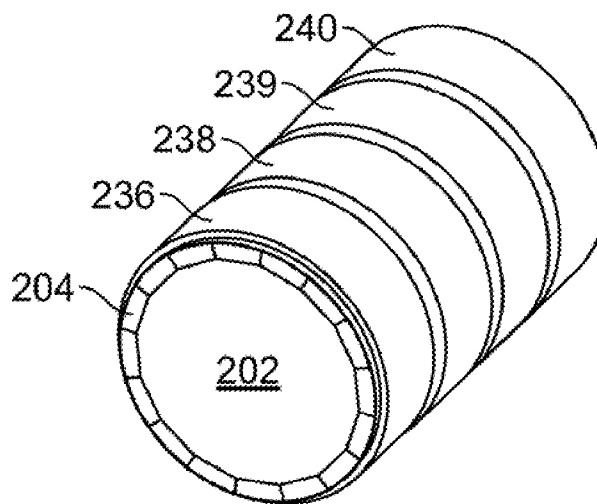

FIG. 2G

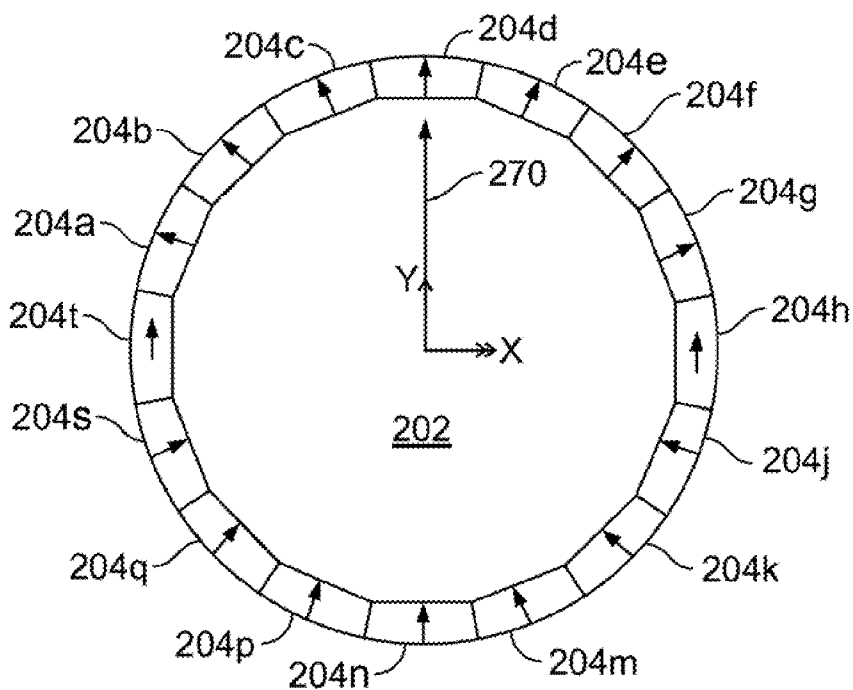

FIG. 2H

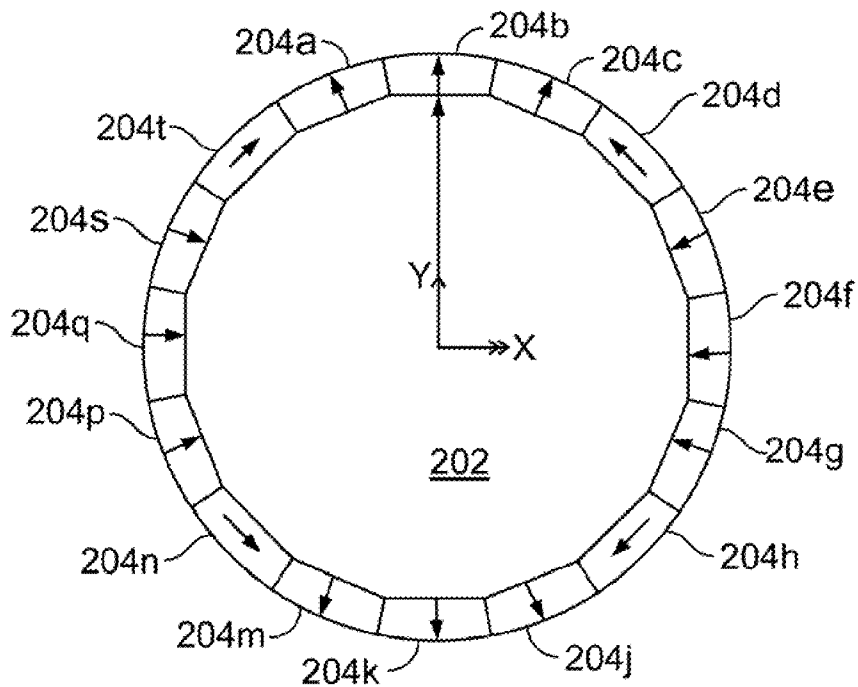

FIG. 2I

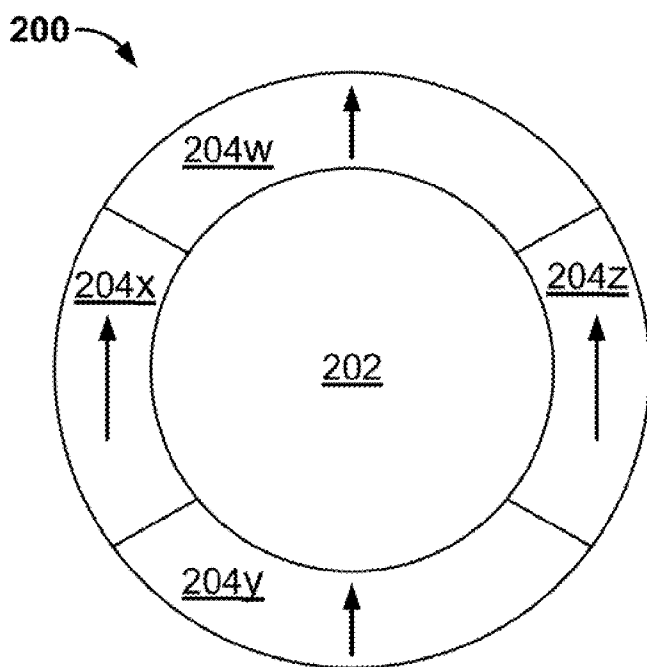

FIG. 2J

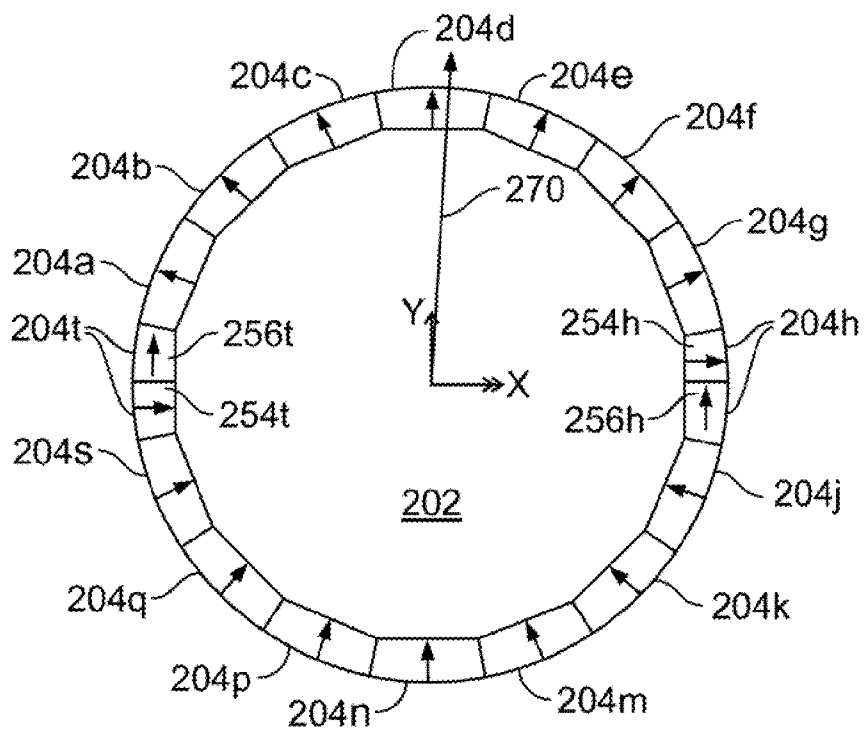

FIG. 2K

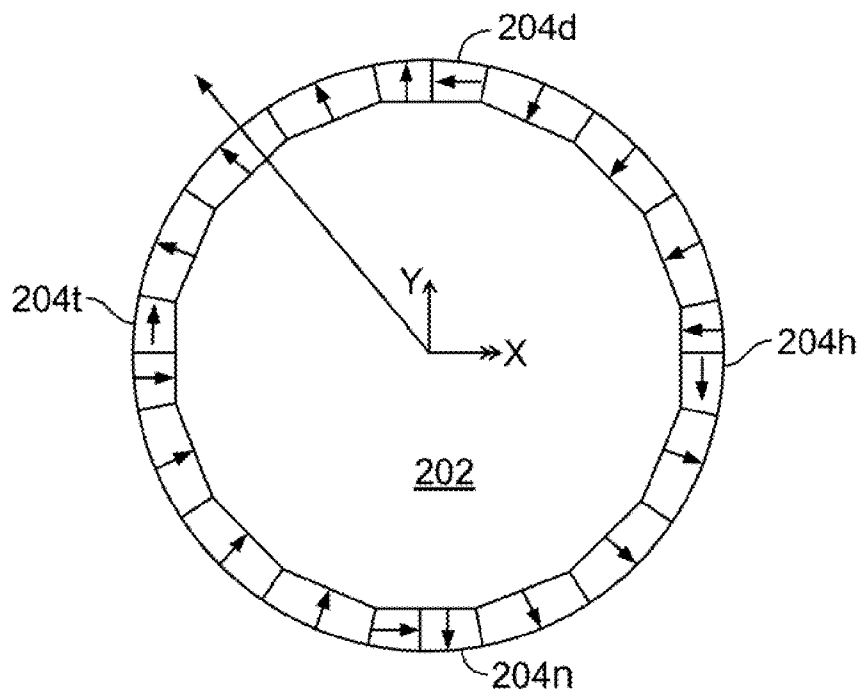

FIG. 2L

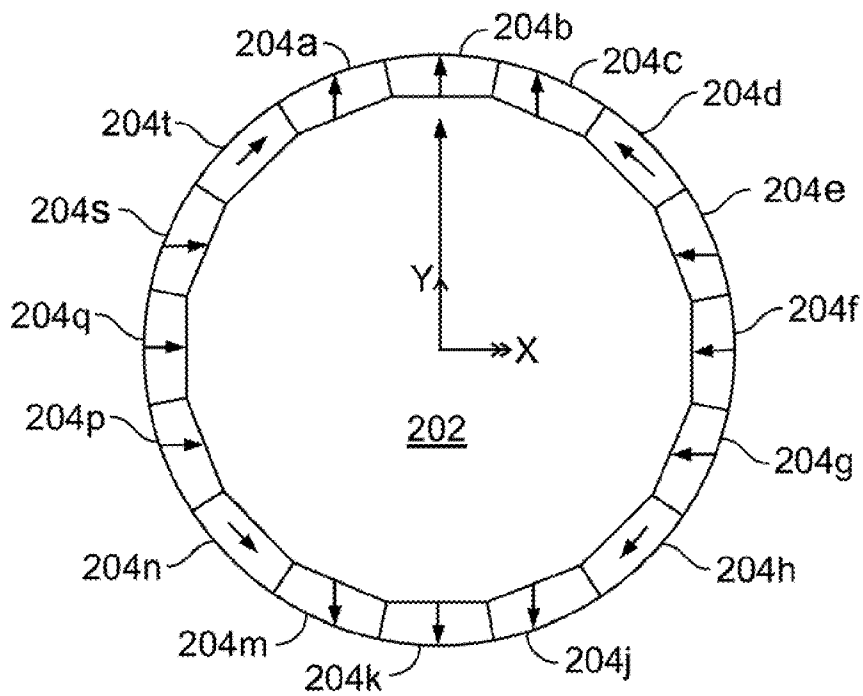

FIG. 2M

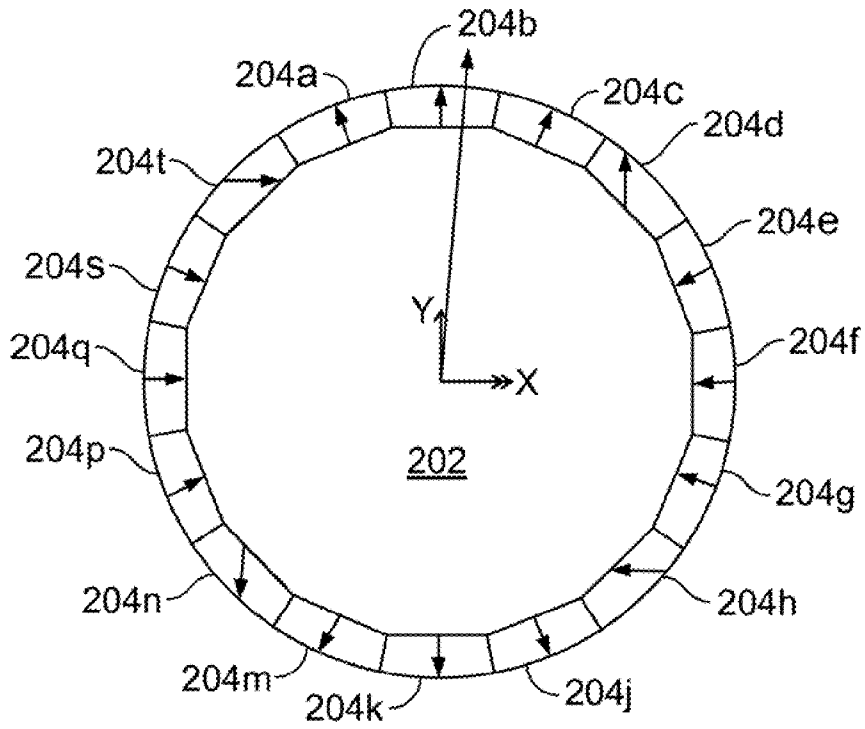

FIG. 2N

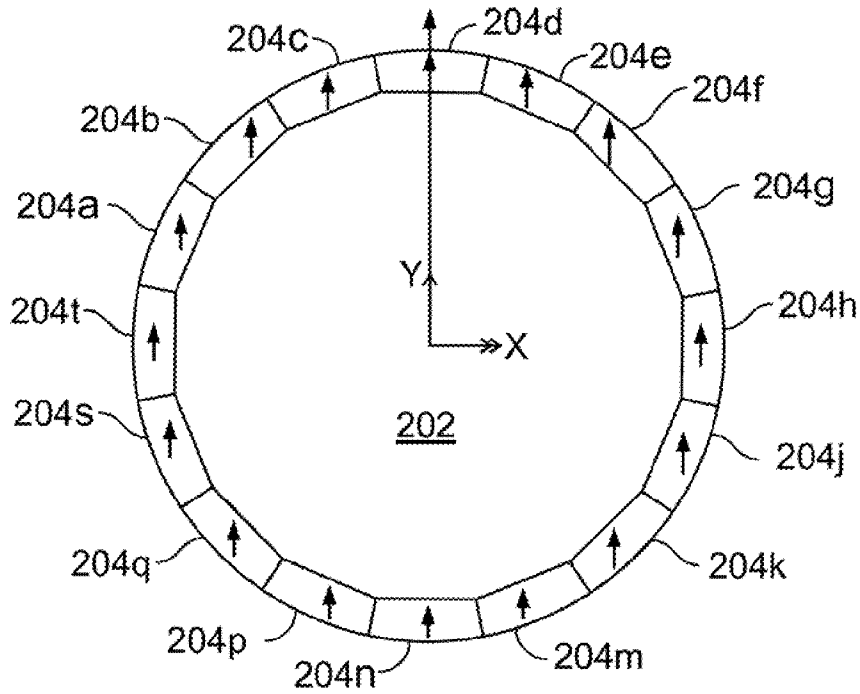

FIG. 2O

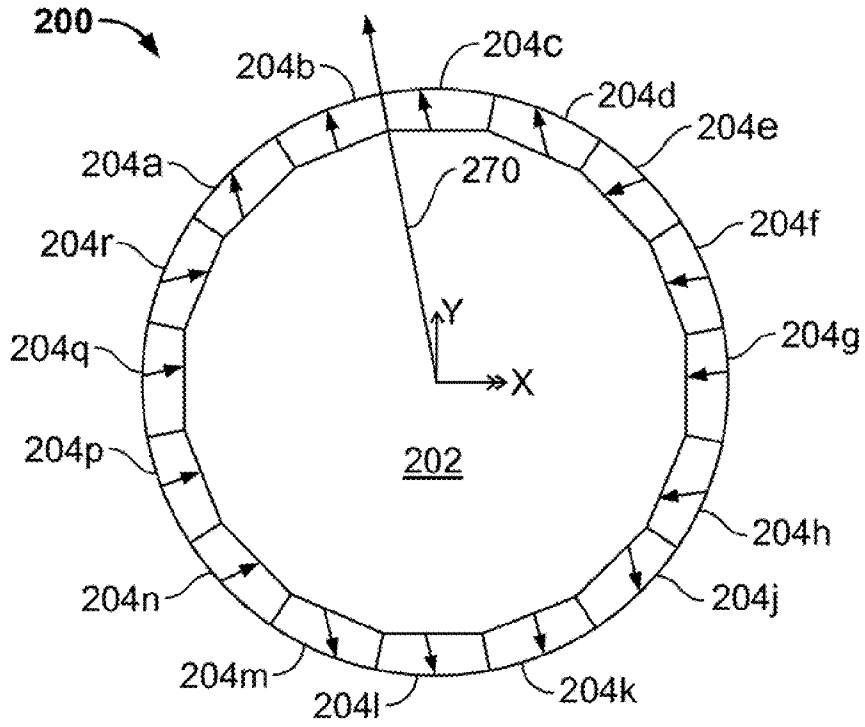

FIG. 2P

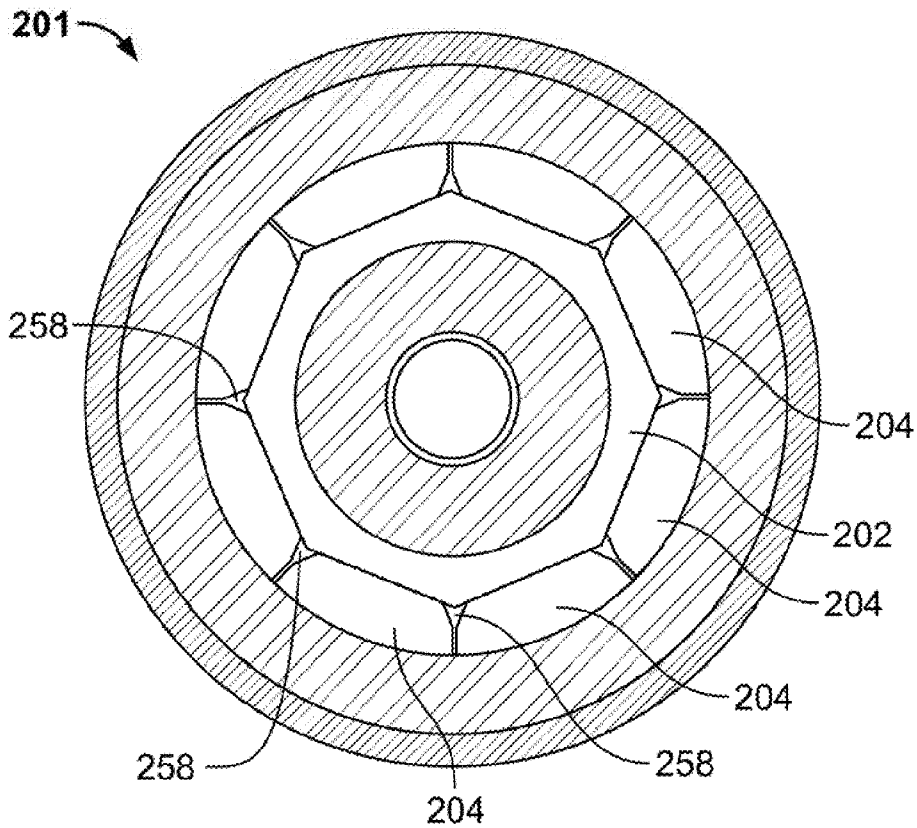
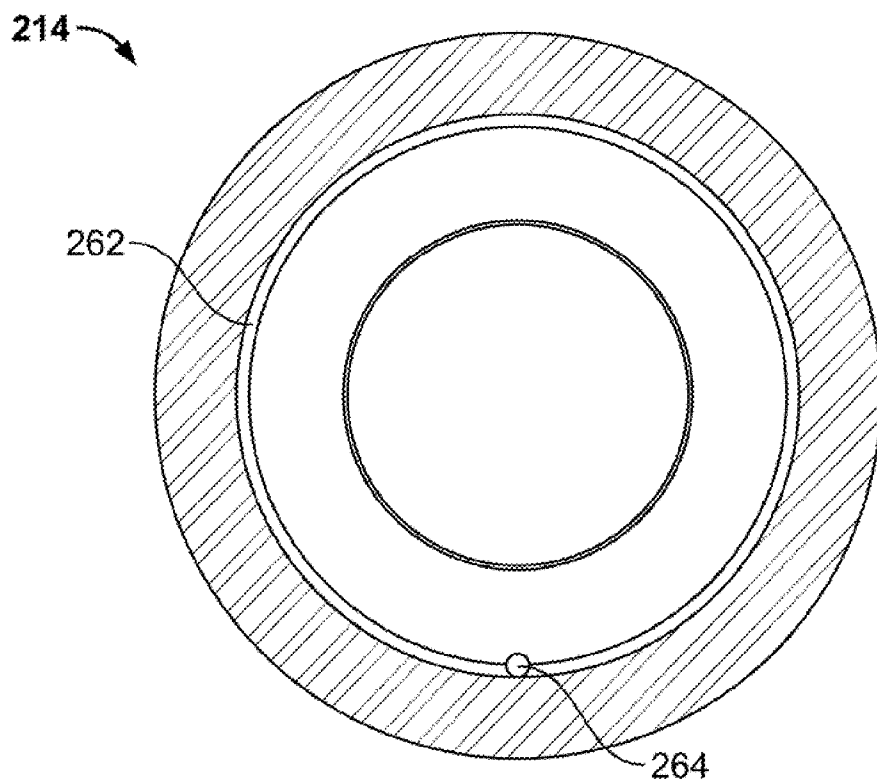
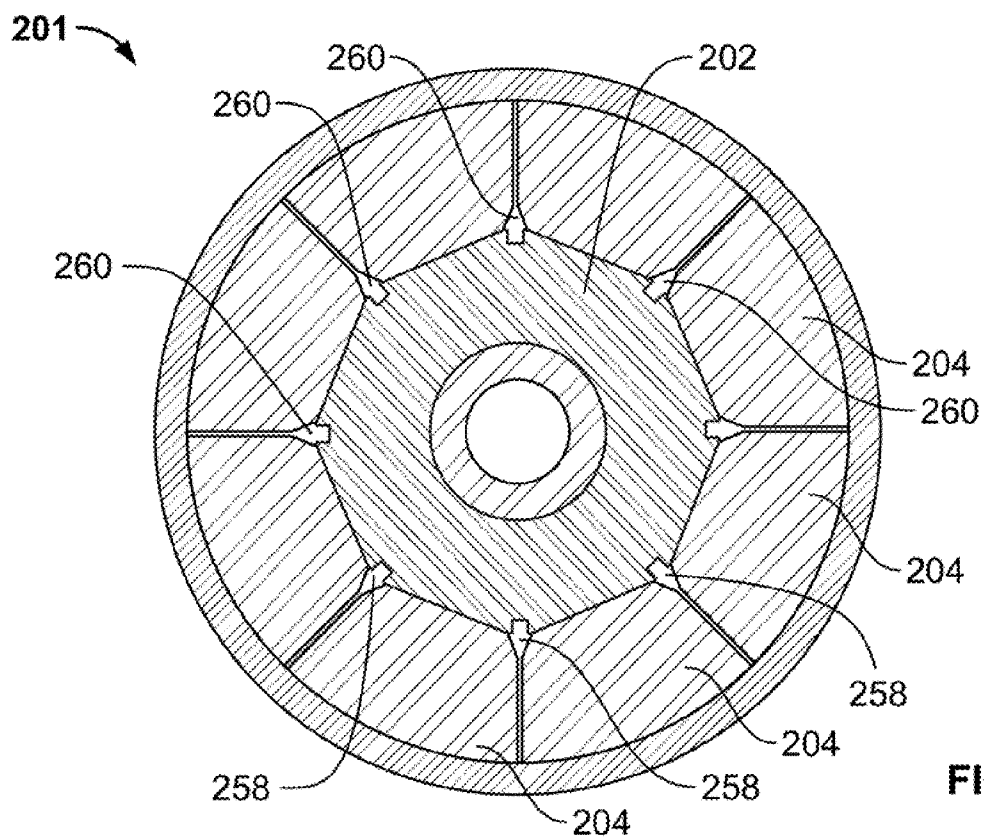

FIG. 2Q



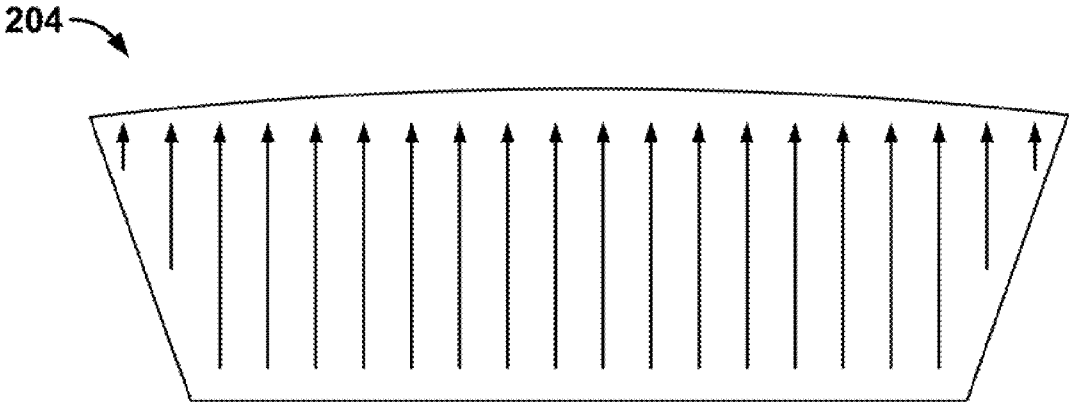

FIG. 2T

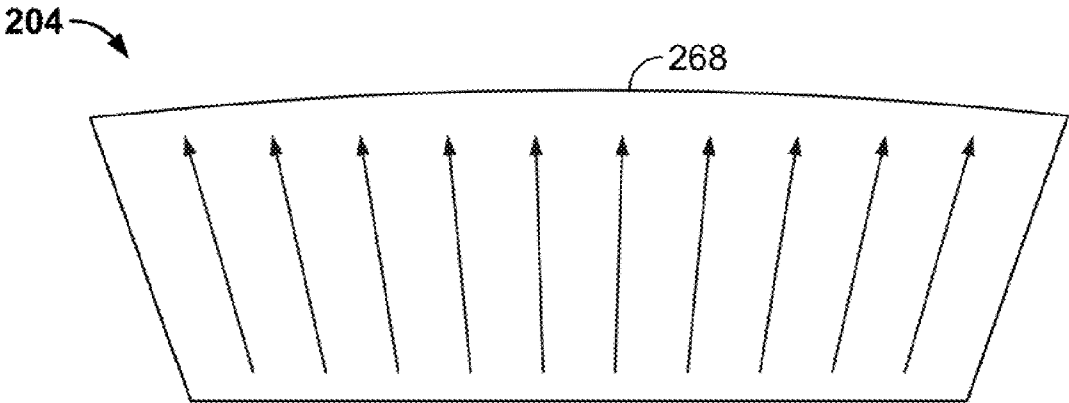

FIG. 2U

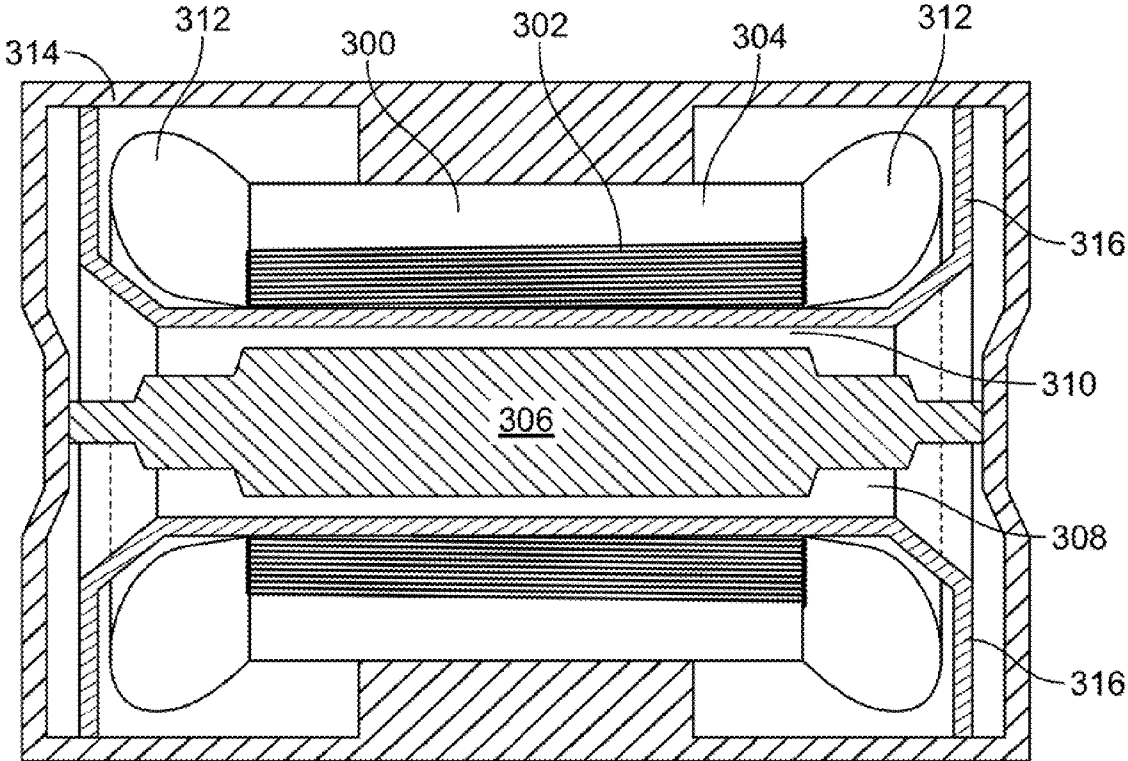

FIG. 3A

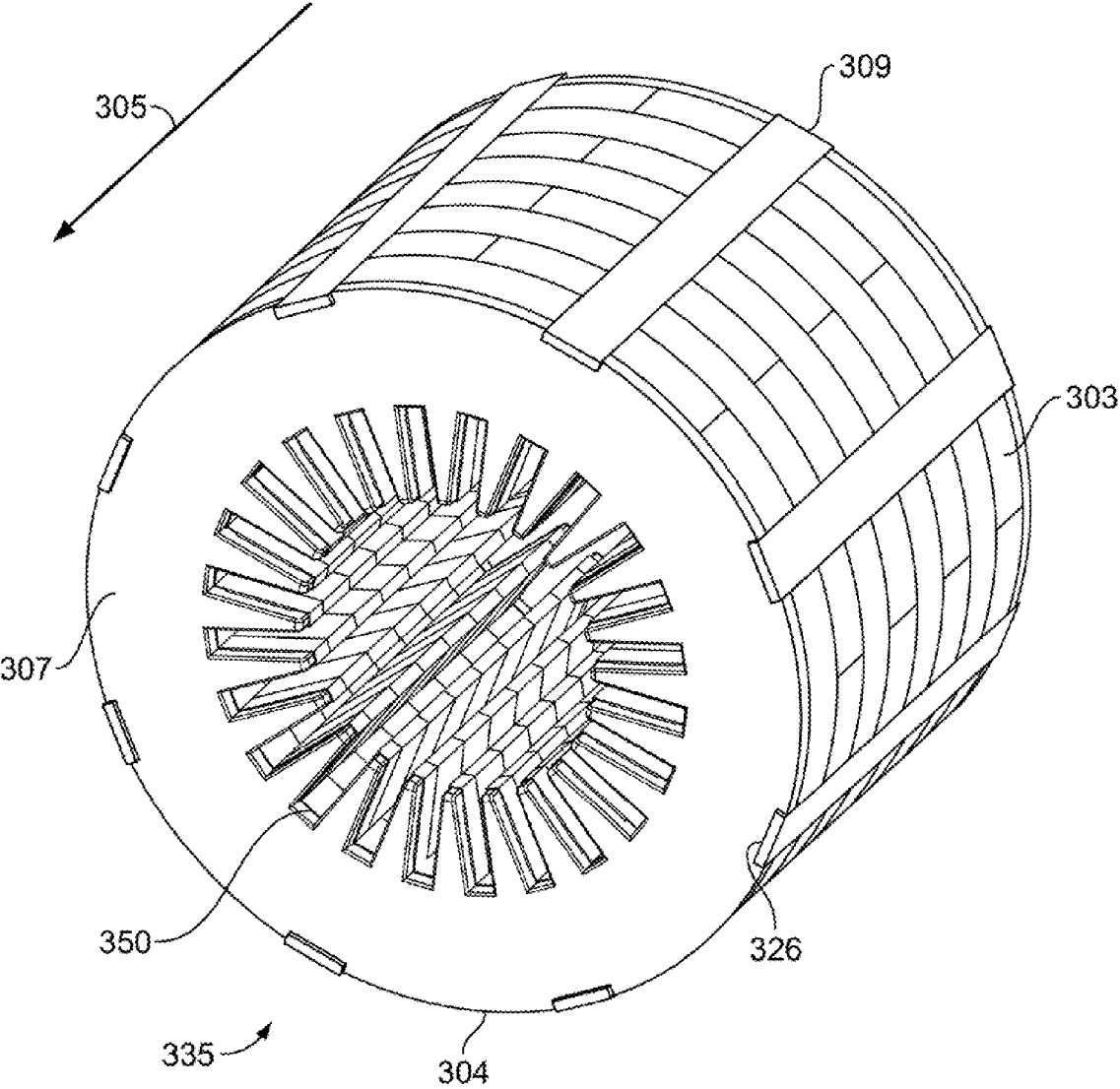

FIG. 3B

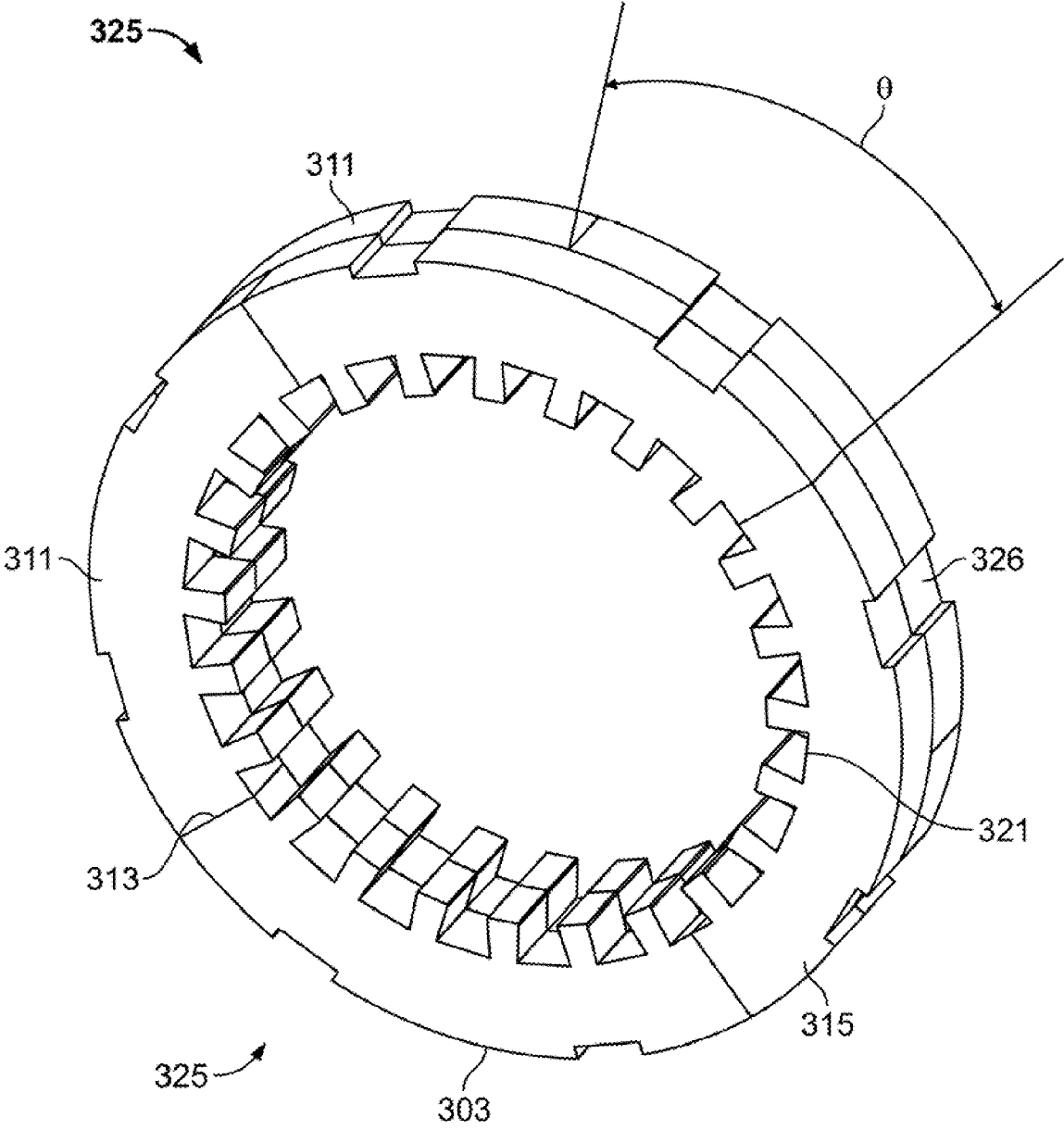

FIG. 3C

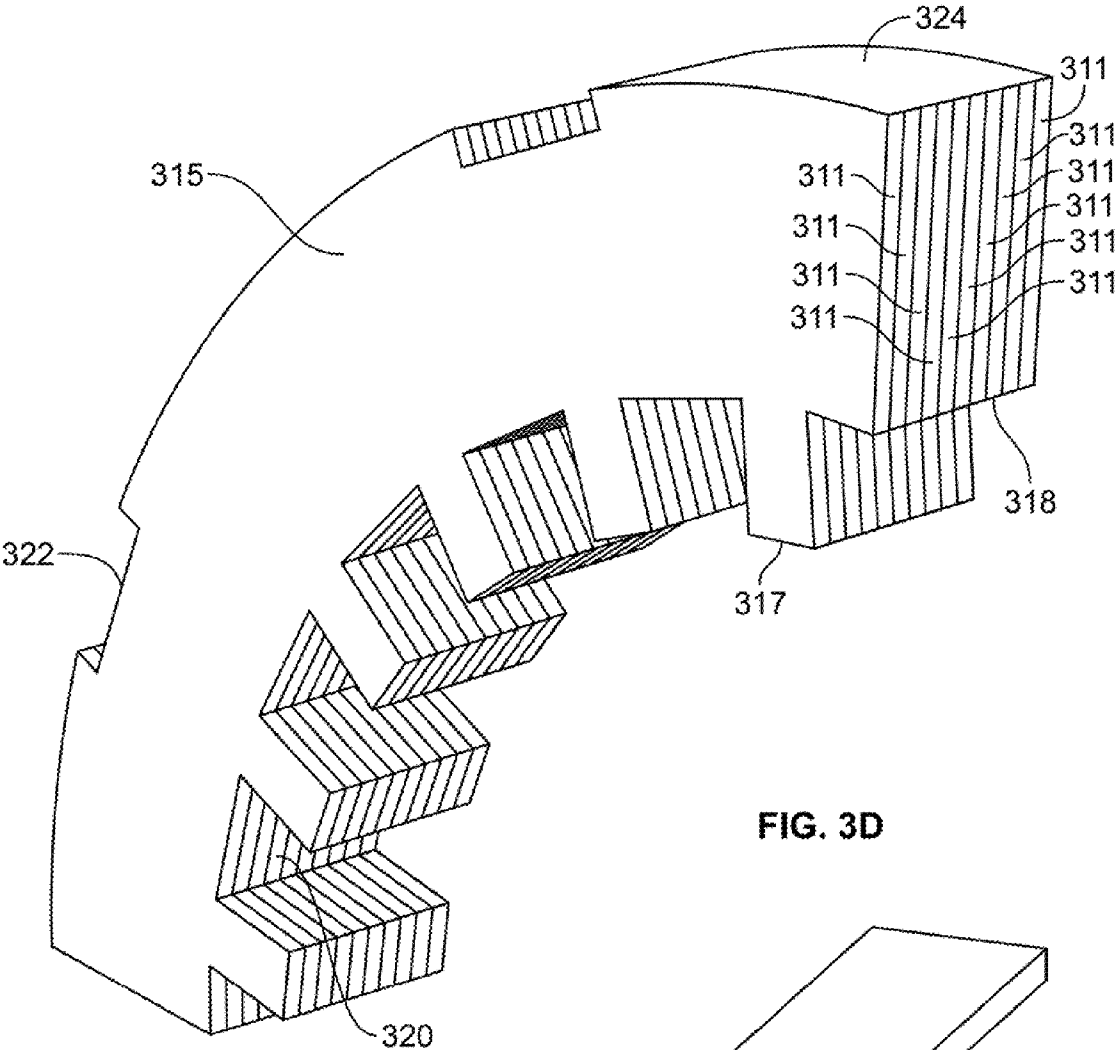

FIG. 3D

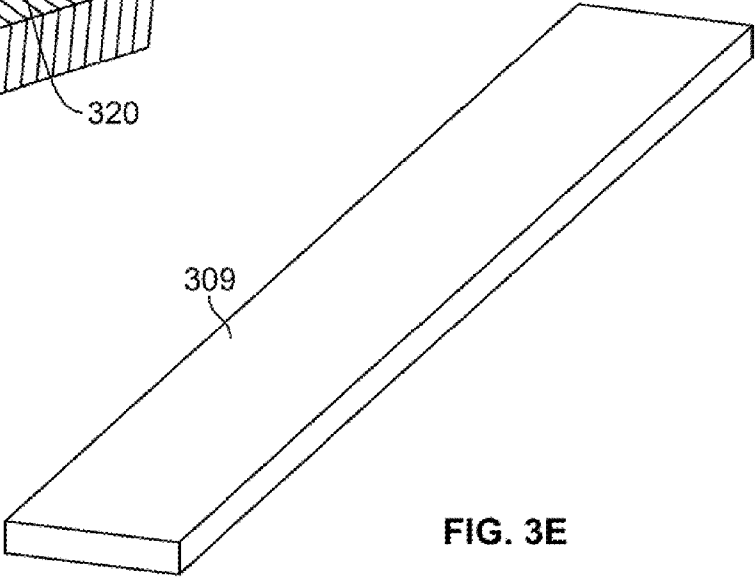

FIG. 3E

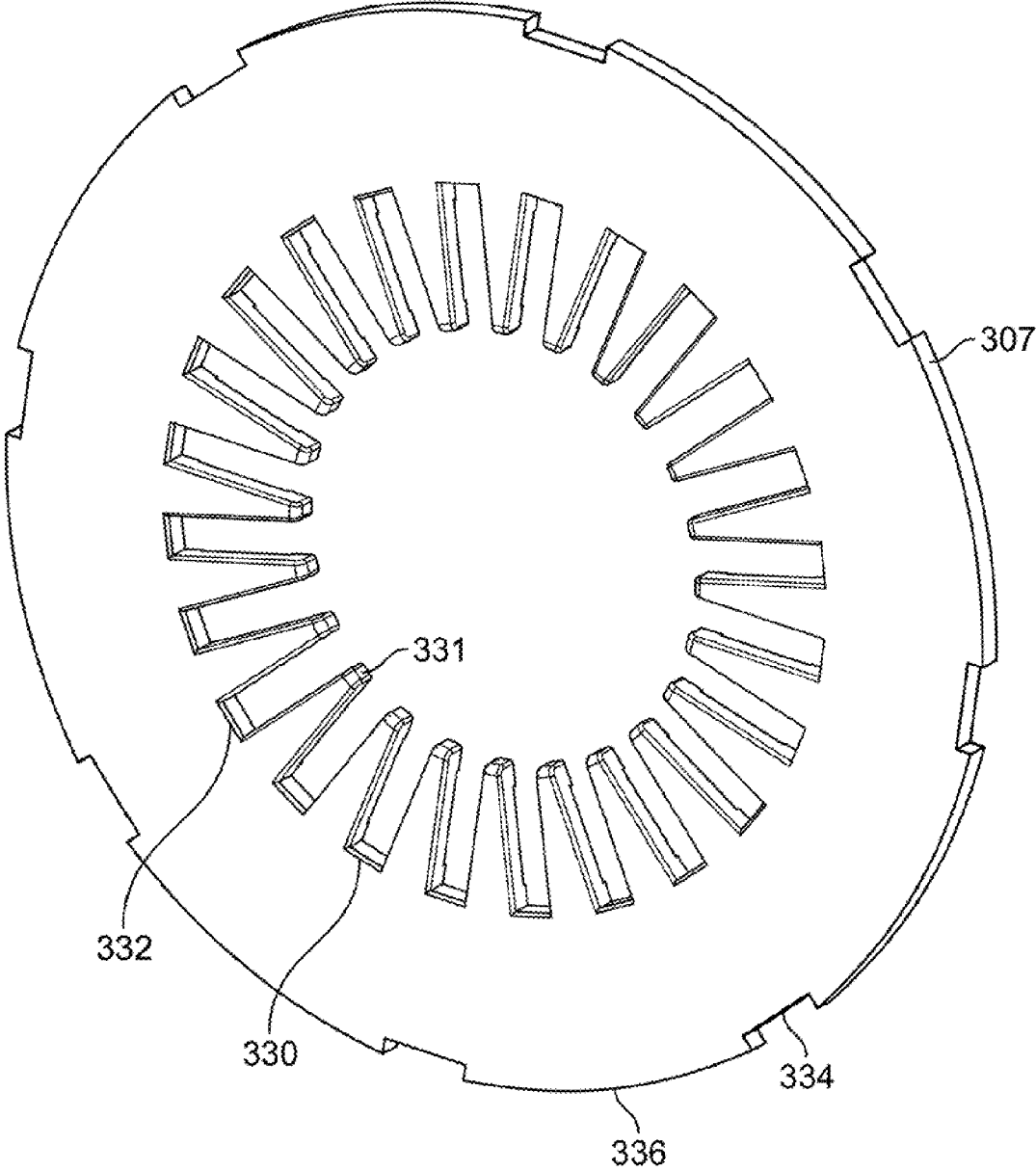

FIG. 3F

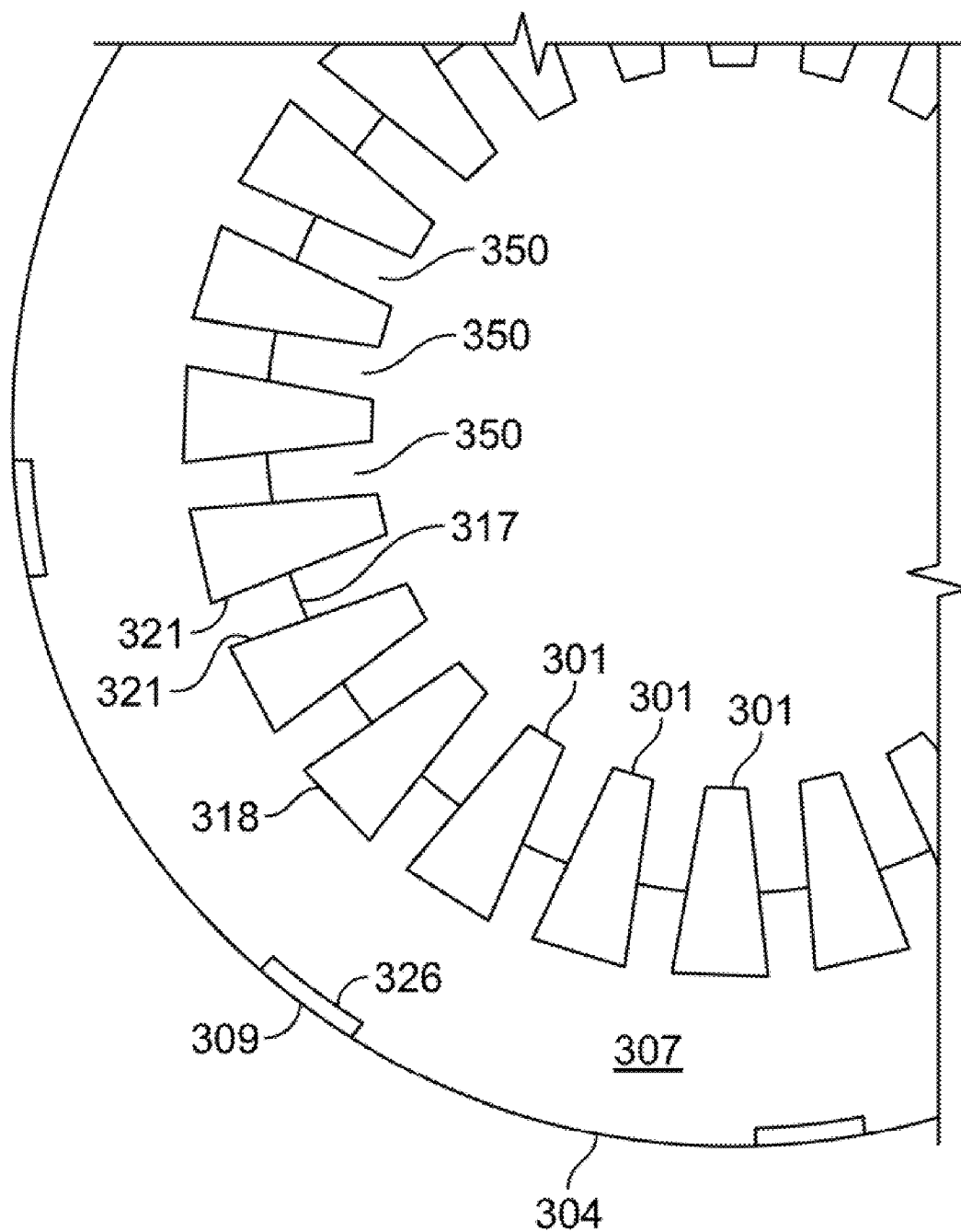

FIG. 3G

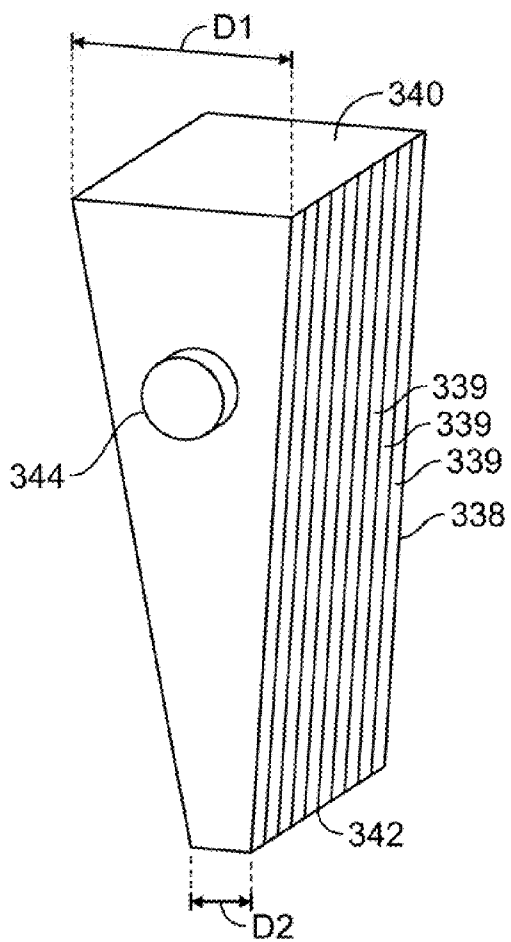

FIG. 3H

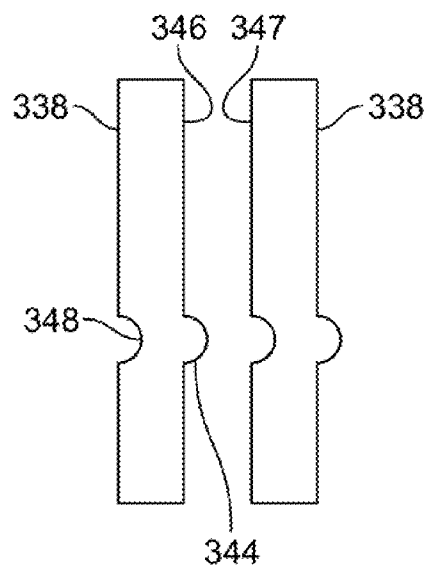

FIG. 3I

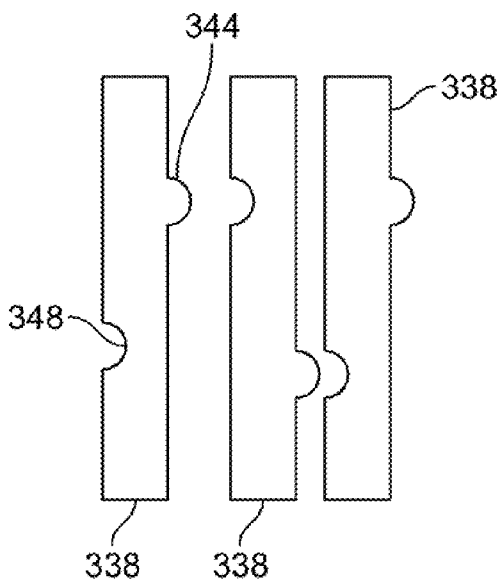

FIG. 3J

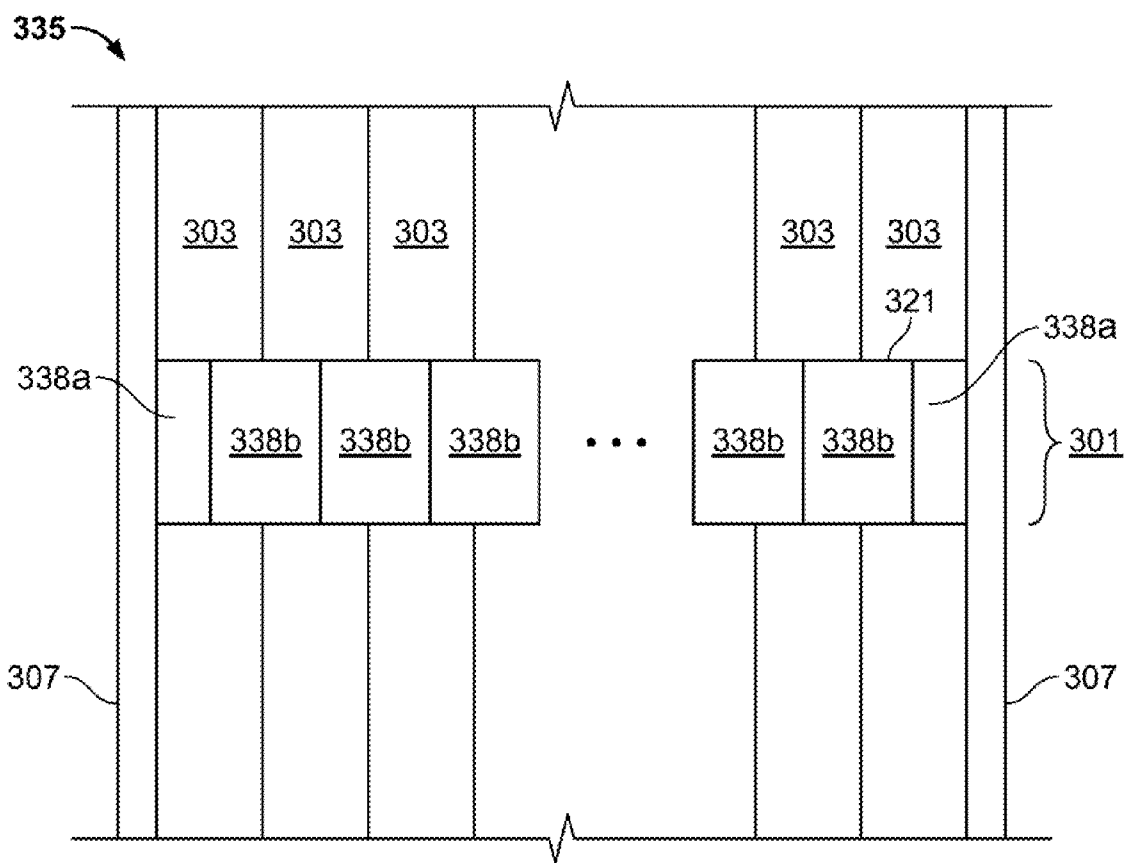

FIG. 3K

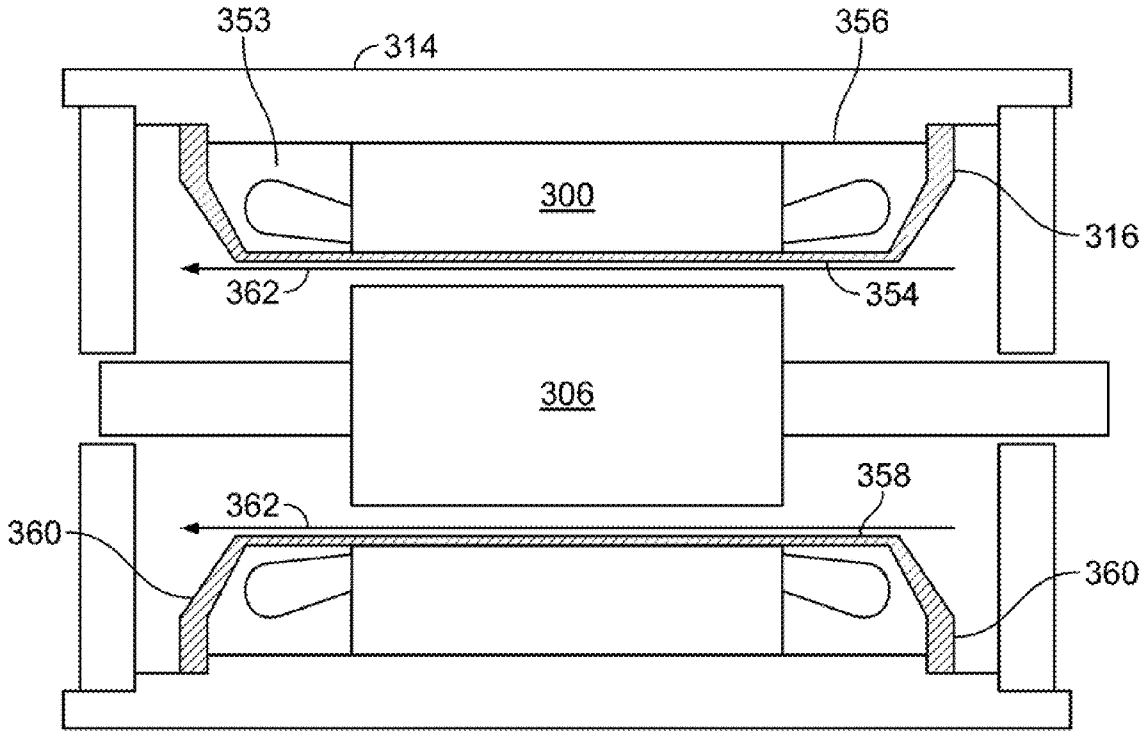

FIG. 3L

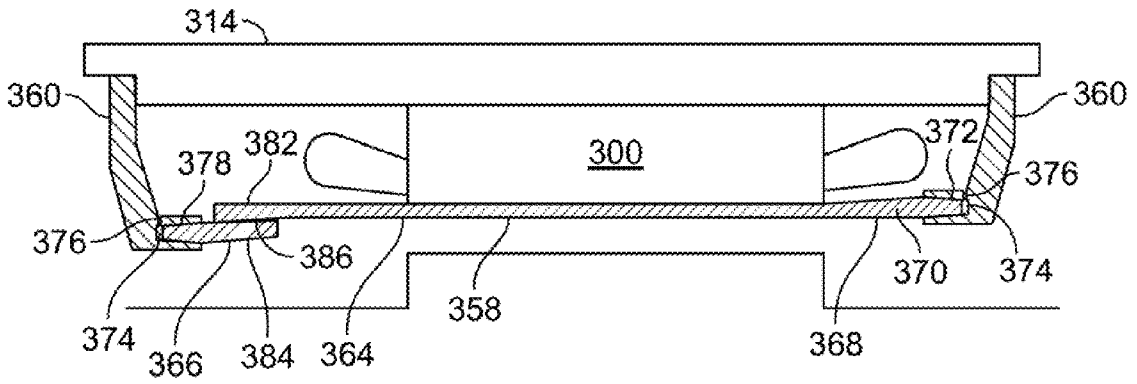

FIG. 3M

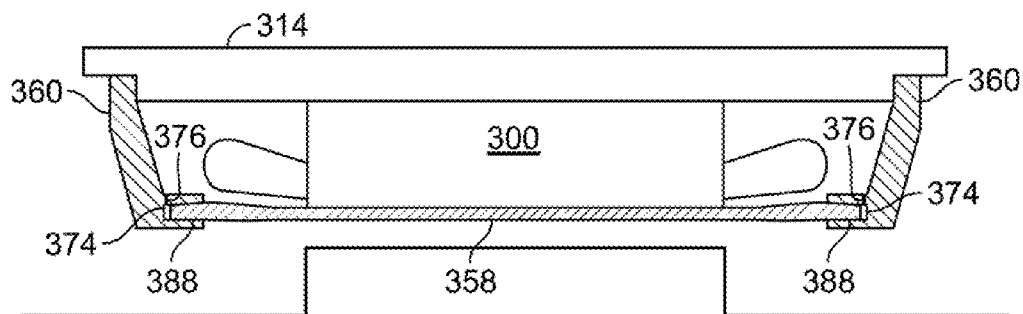

FIG. 3N

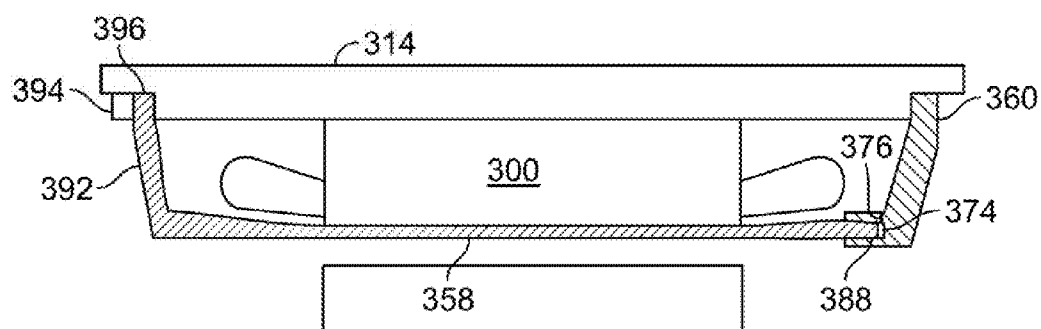

FIG. 3O

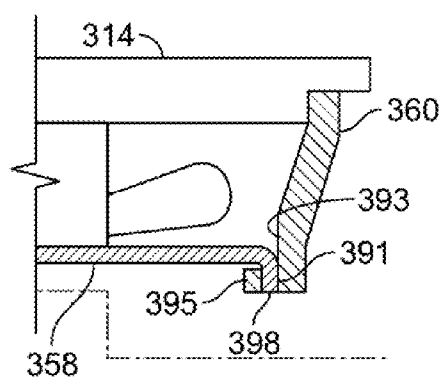

FIG. 3P

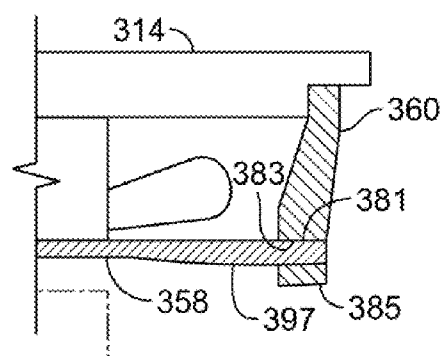

FIG. 3Q

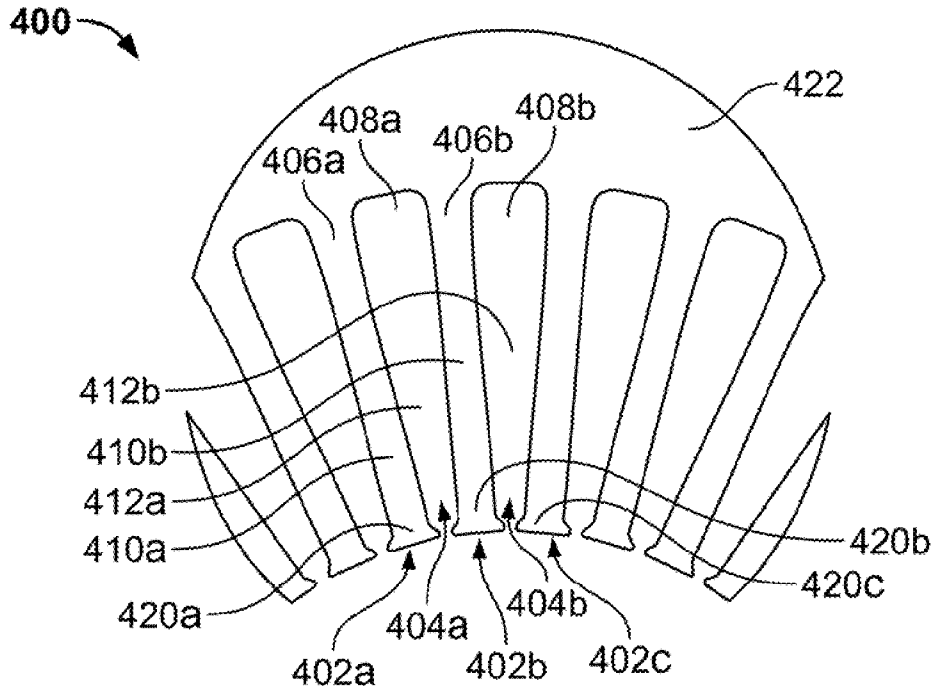

FIG. 4A

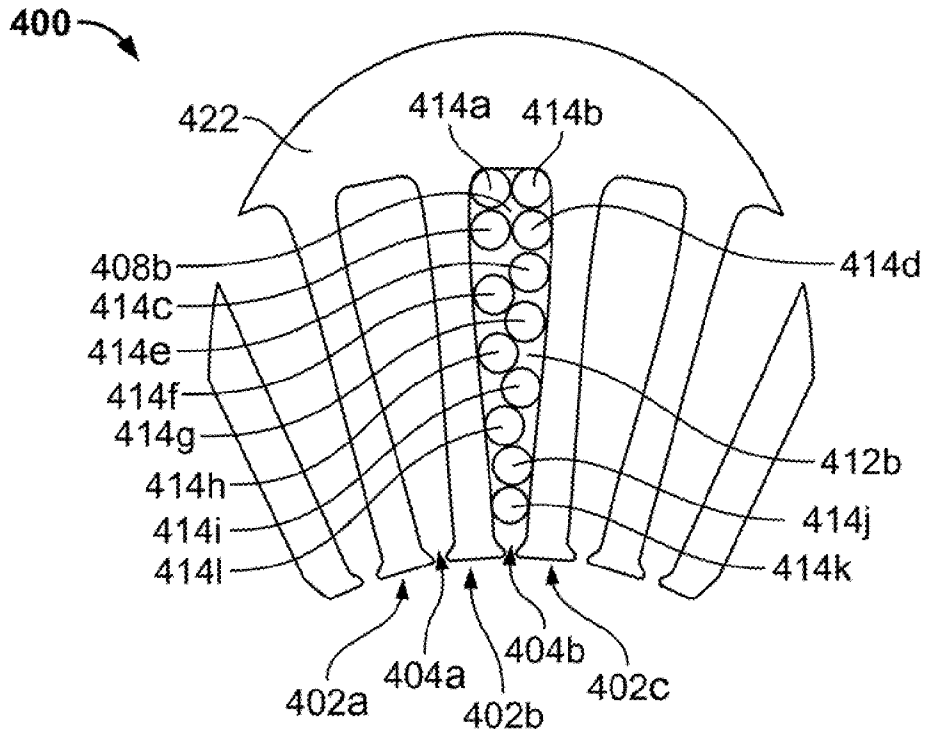

FIG. 4B

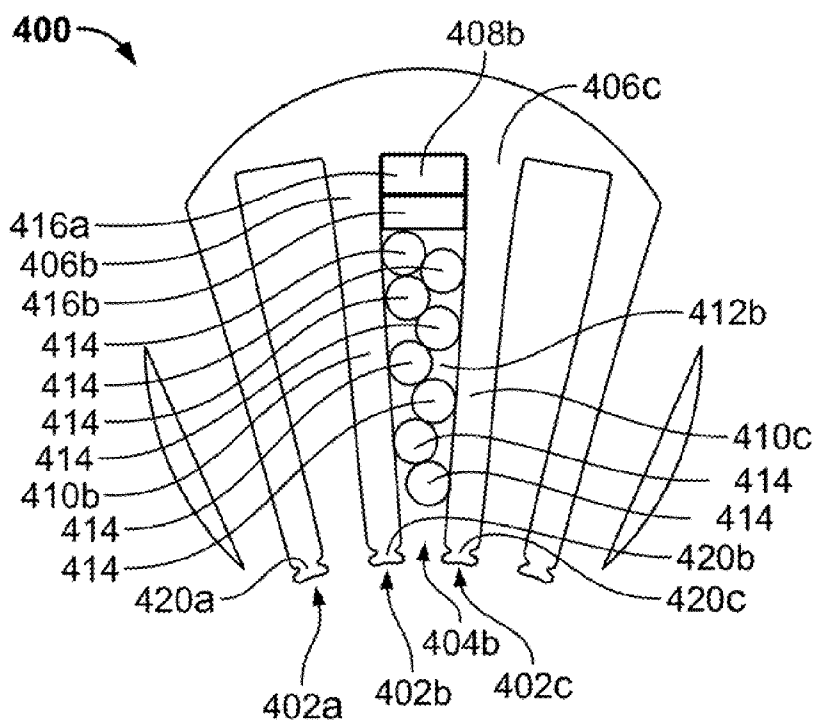

FIG. 4C

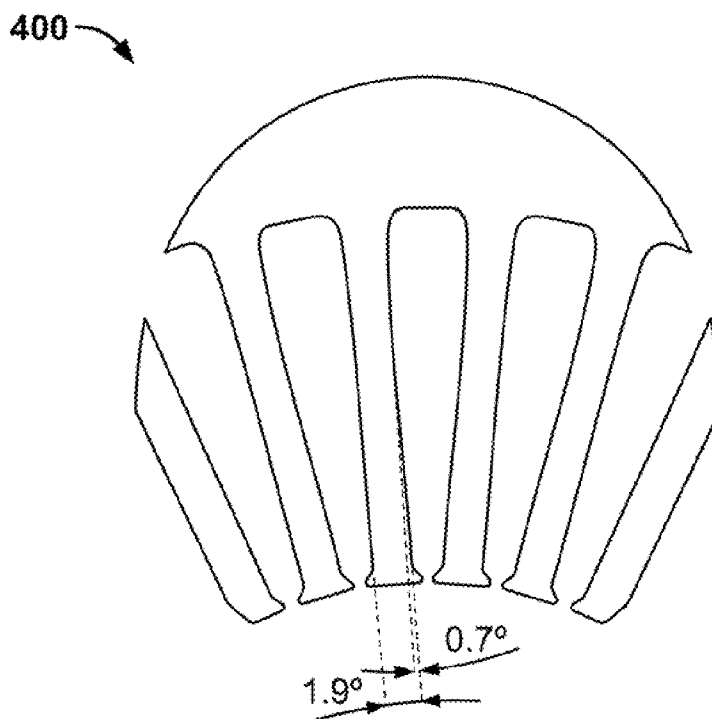

FIG. 4D

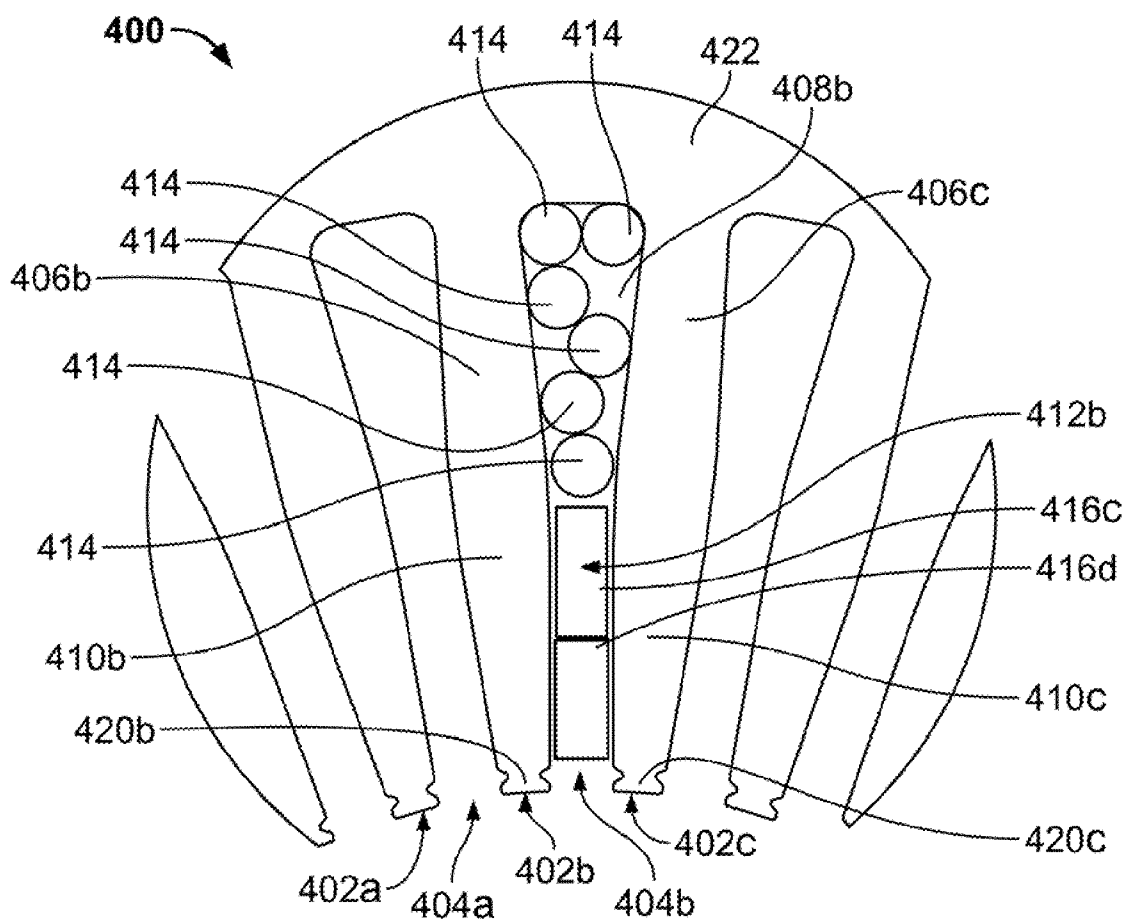

FIG. 4E

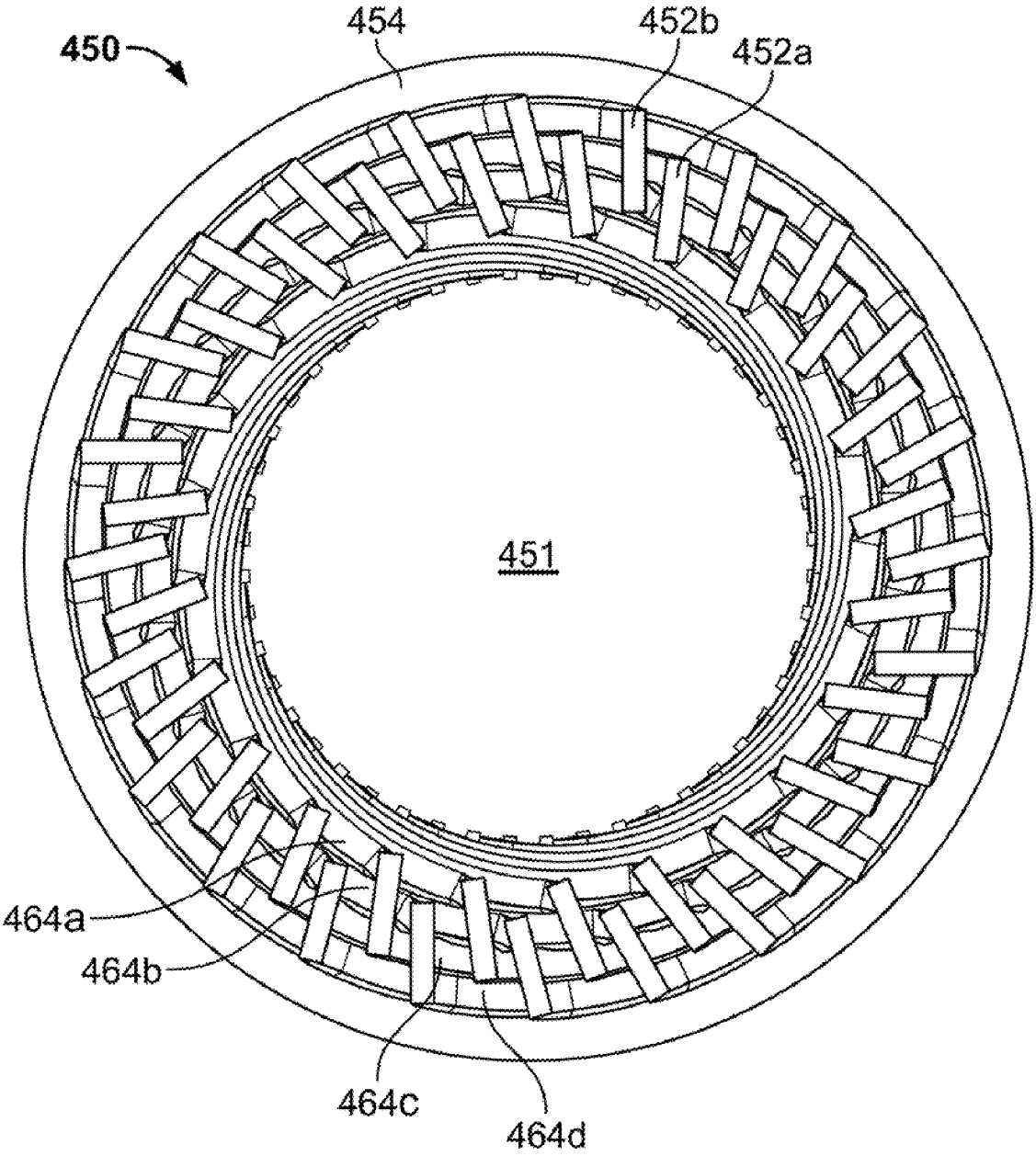

FIG. 4F

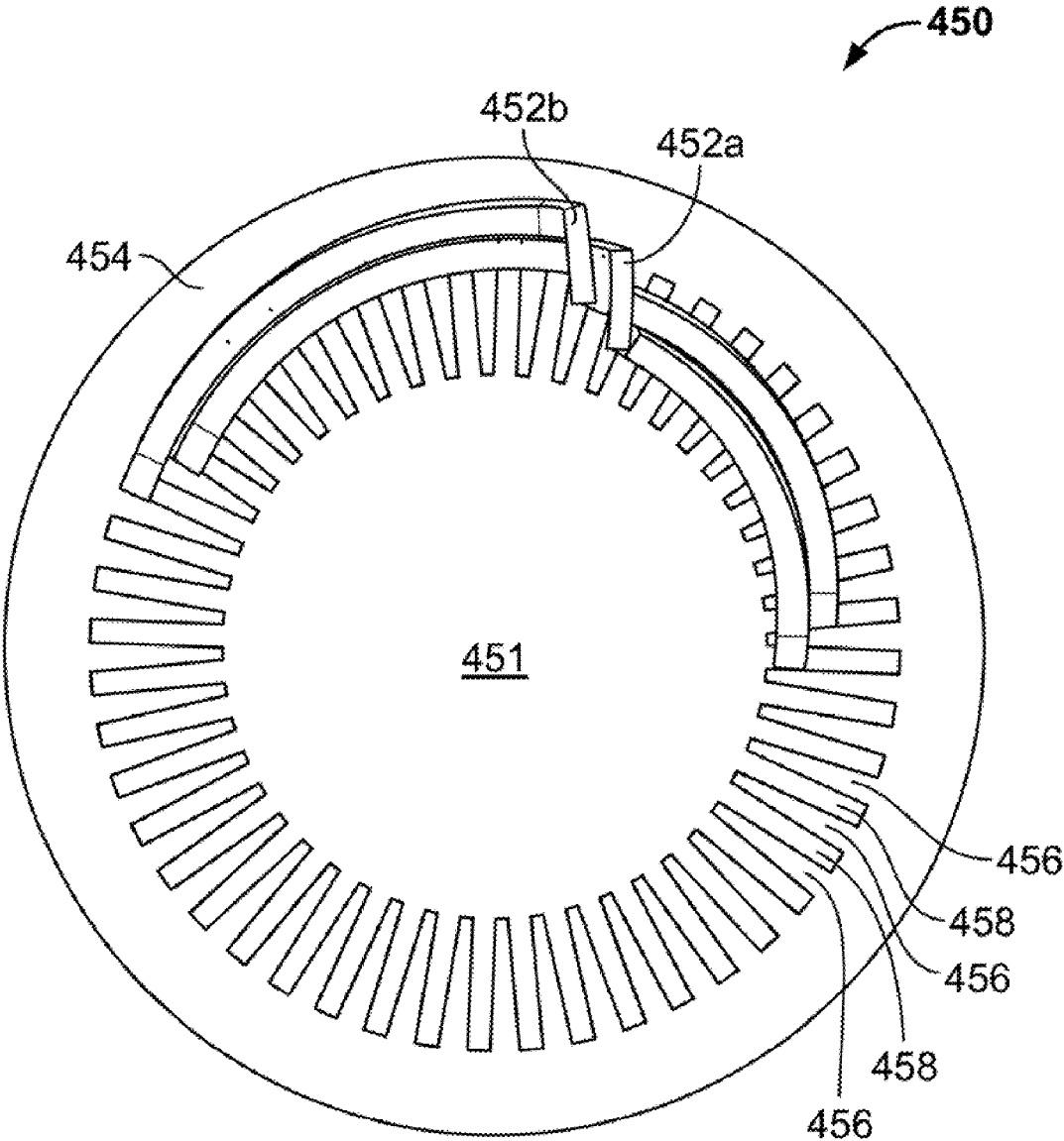

FIG. 4G

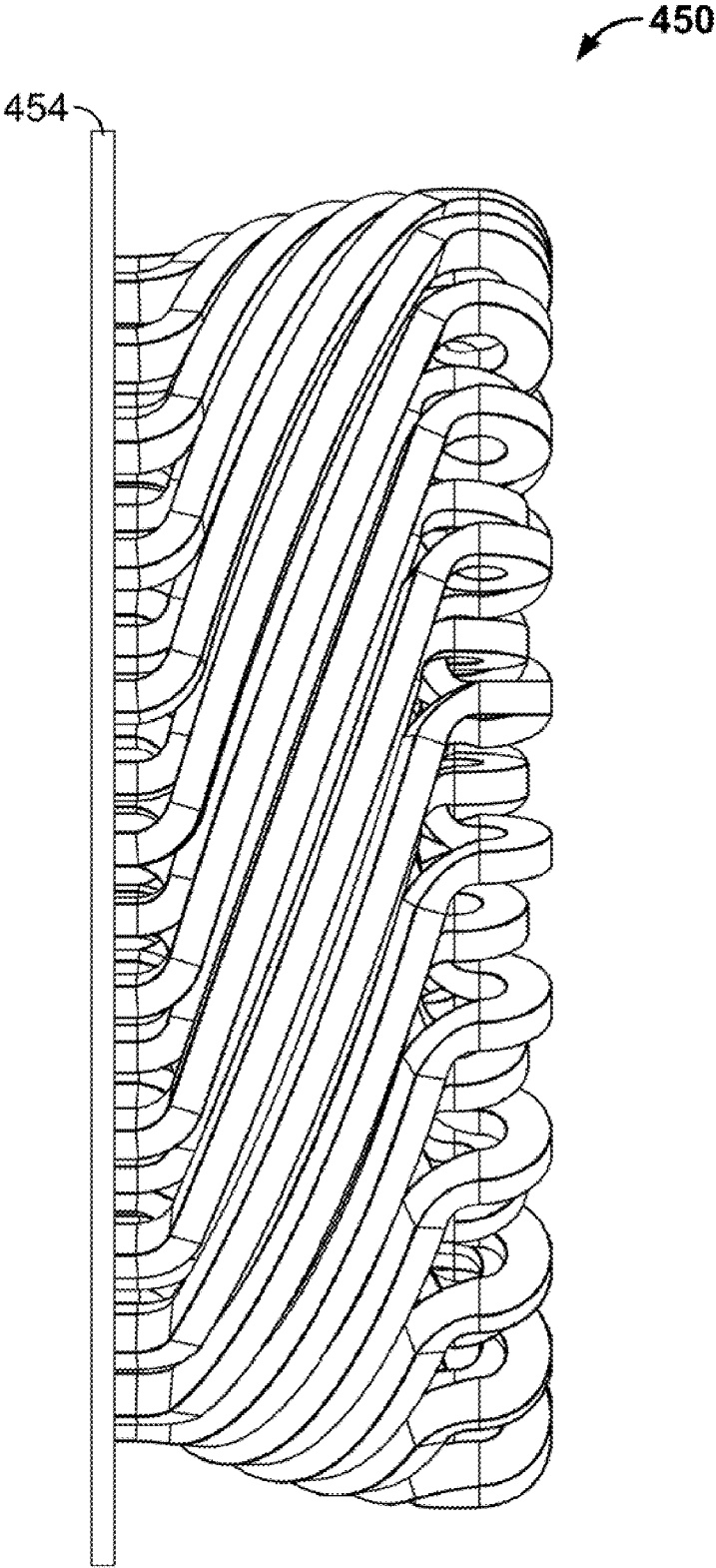

FIG. 4H

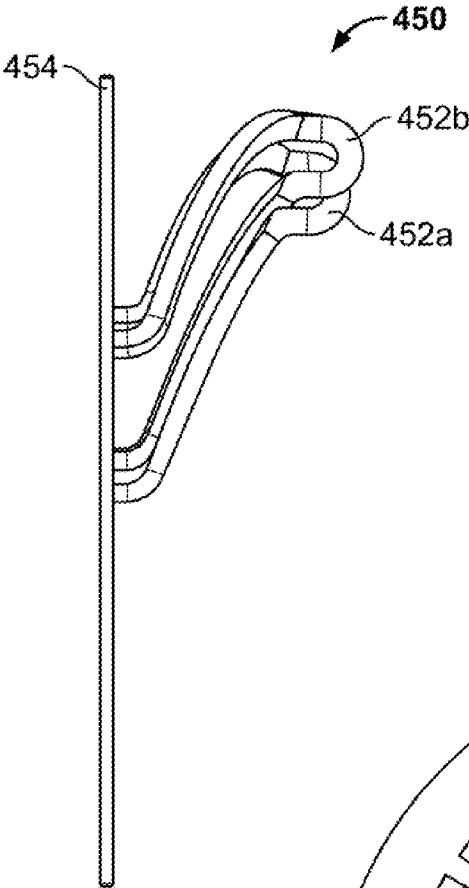

FIG. 4I

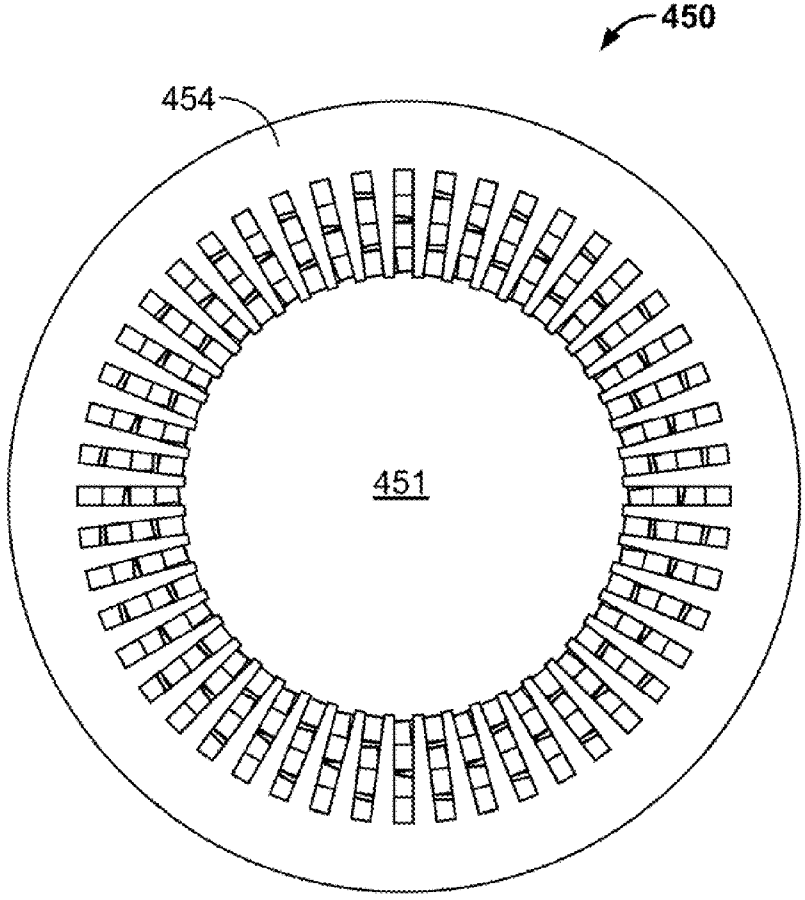

FIG. 4J

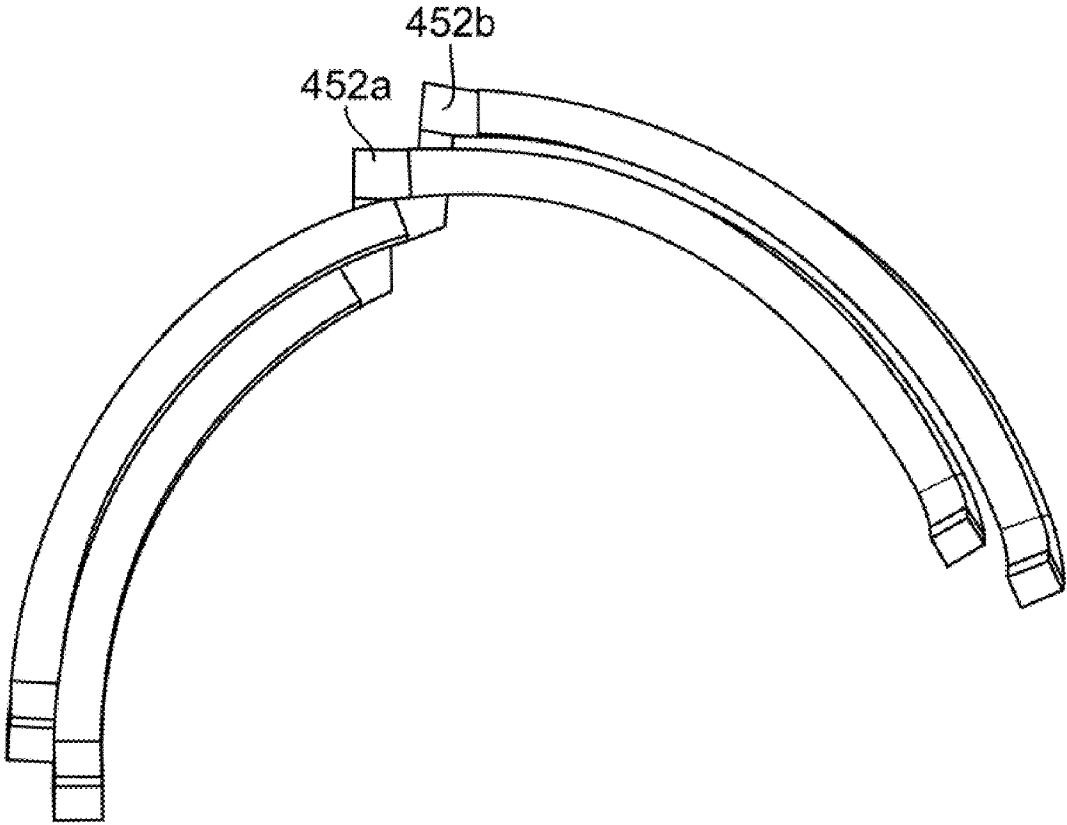

FIG. 4K

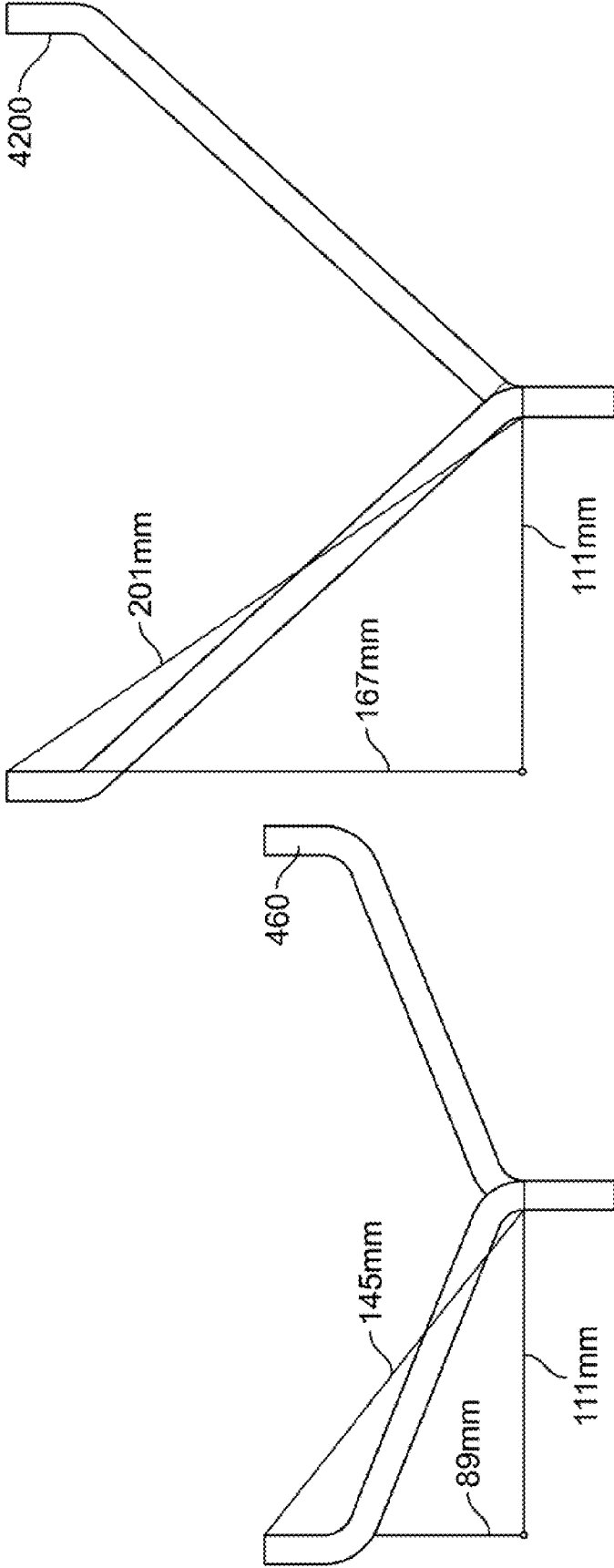

FIG. 4L

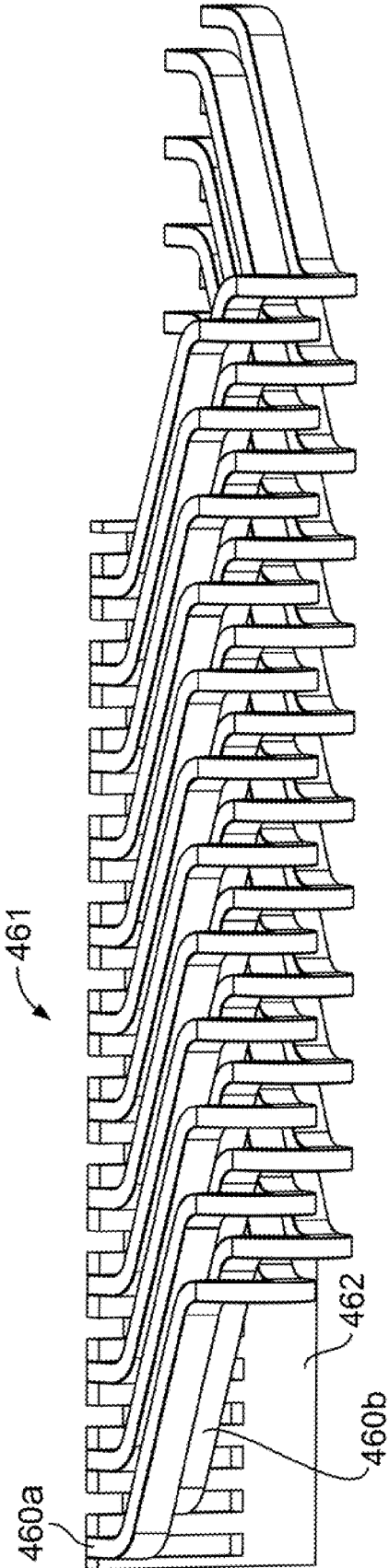

FIG. 4M

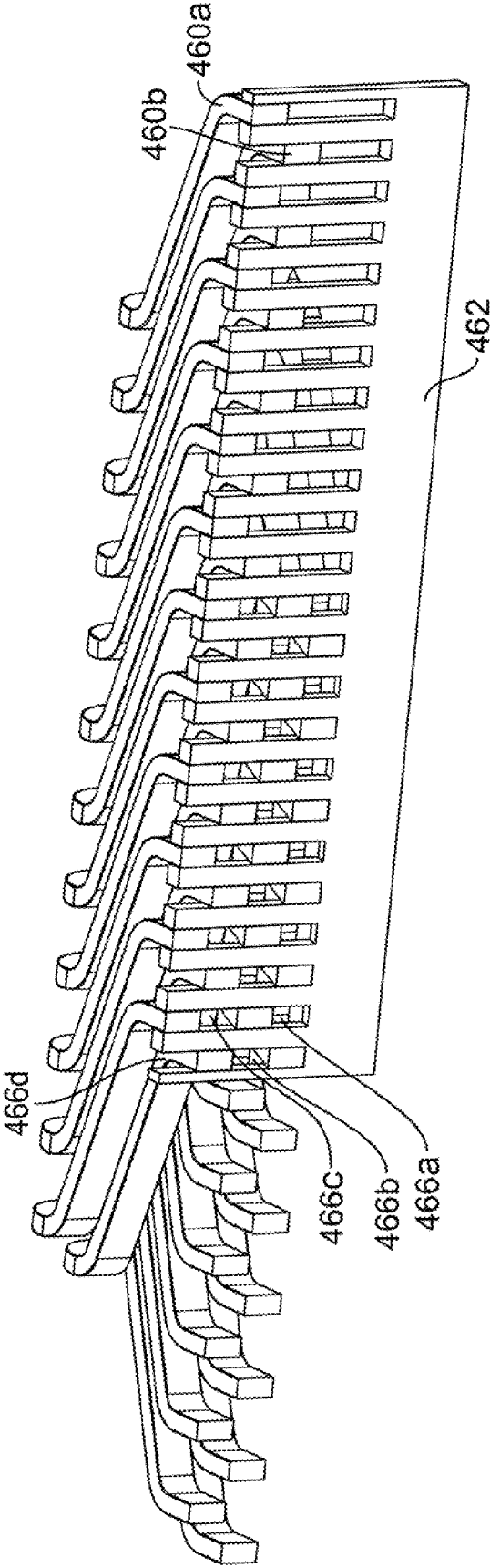

FIG. 4N

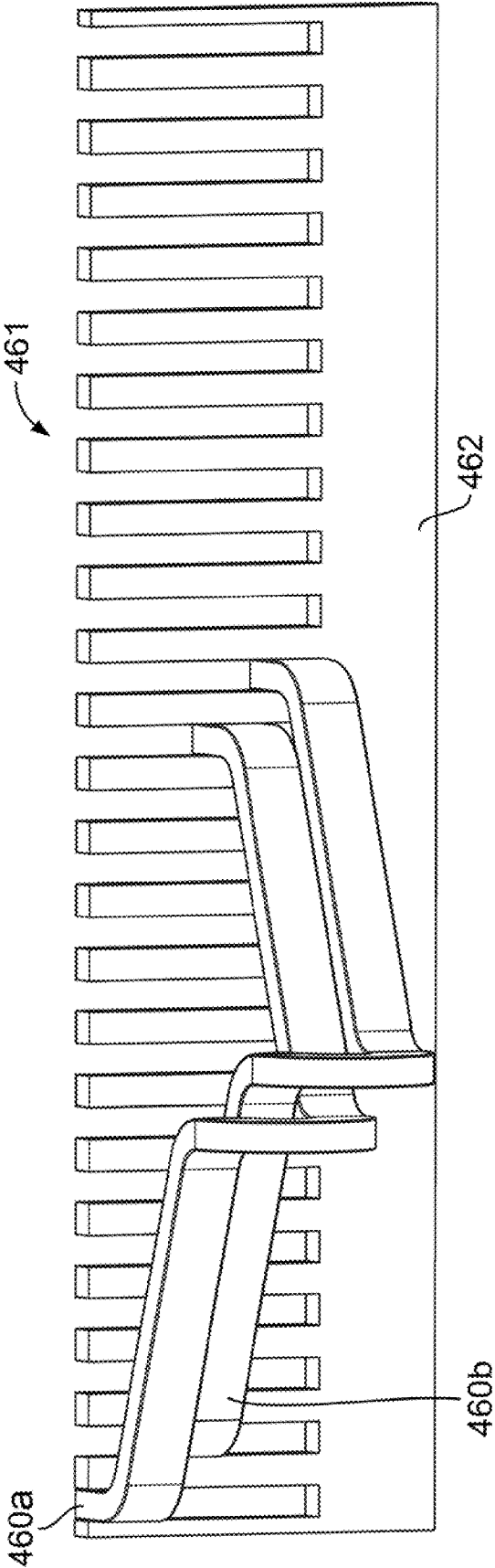

FIG. 40

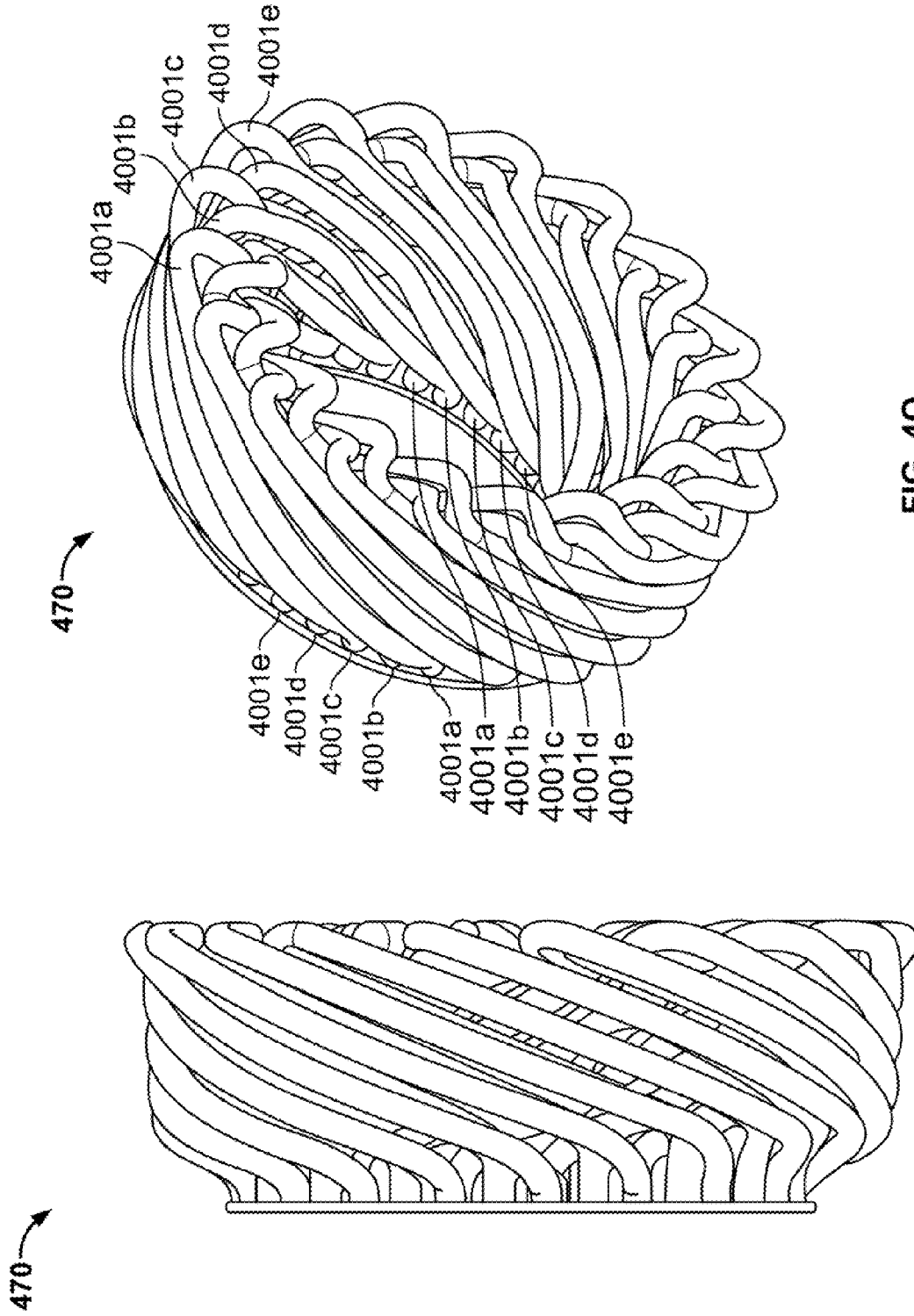
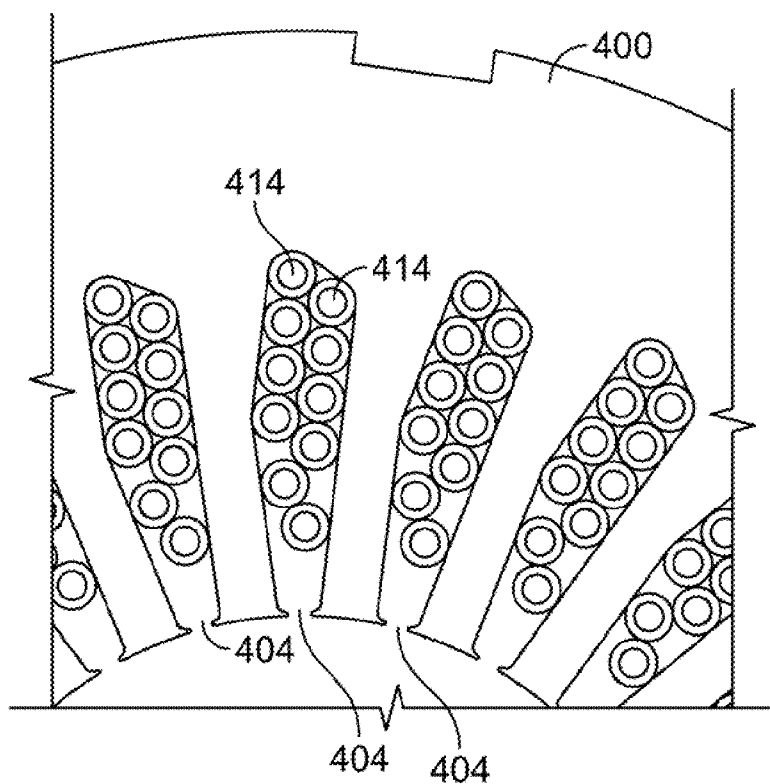
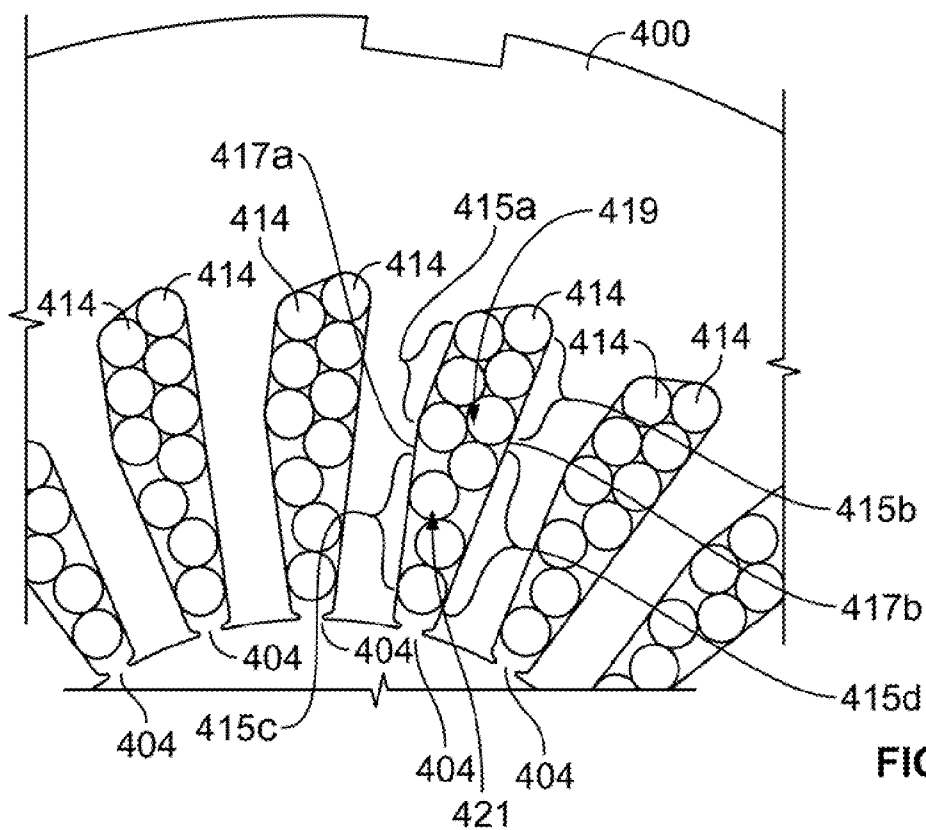

FIG. 4Q

FIG. 4P



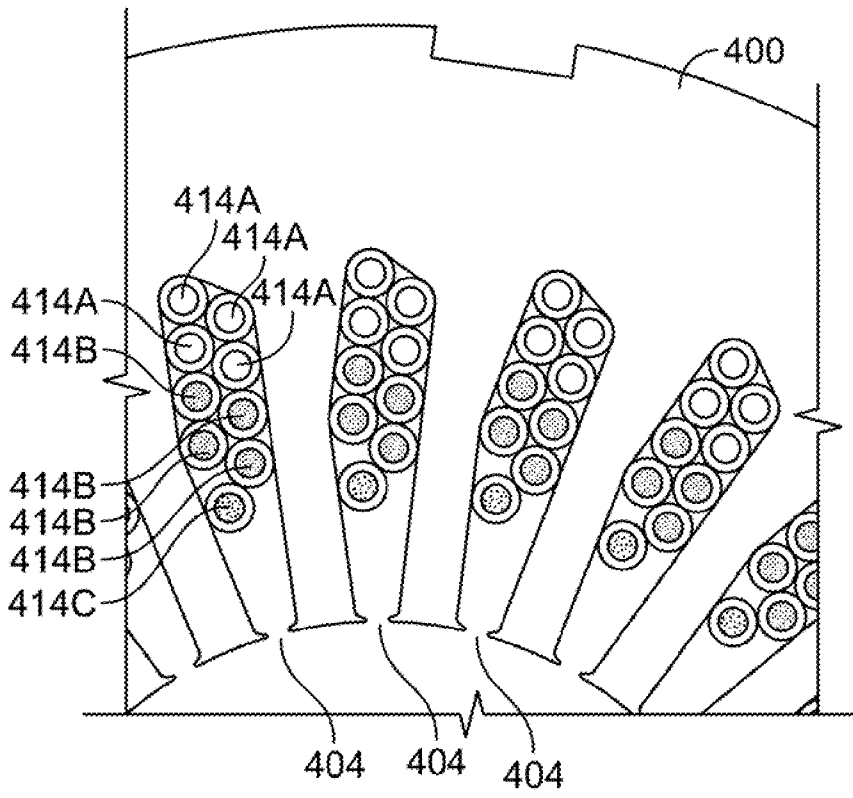

FIG. 4T

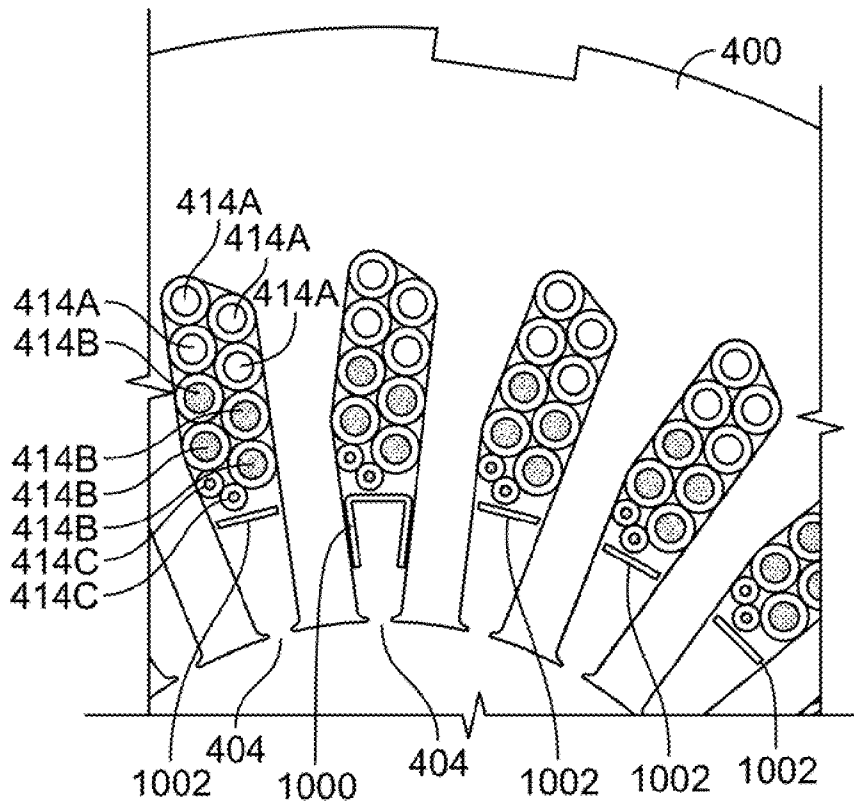

FIG. 4U

1000

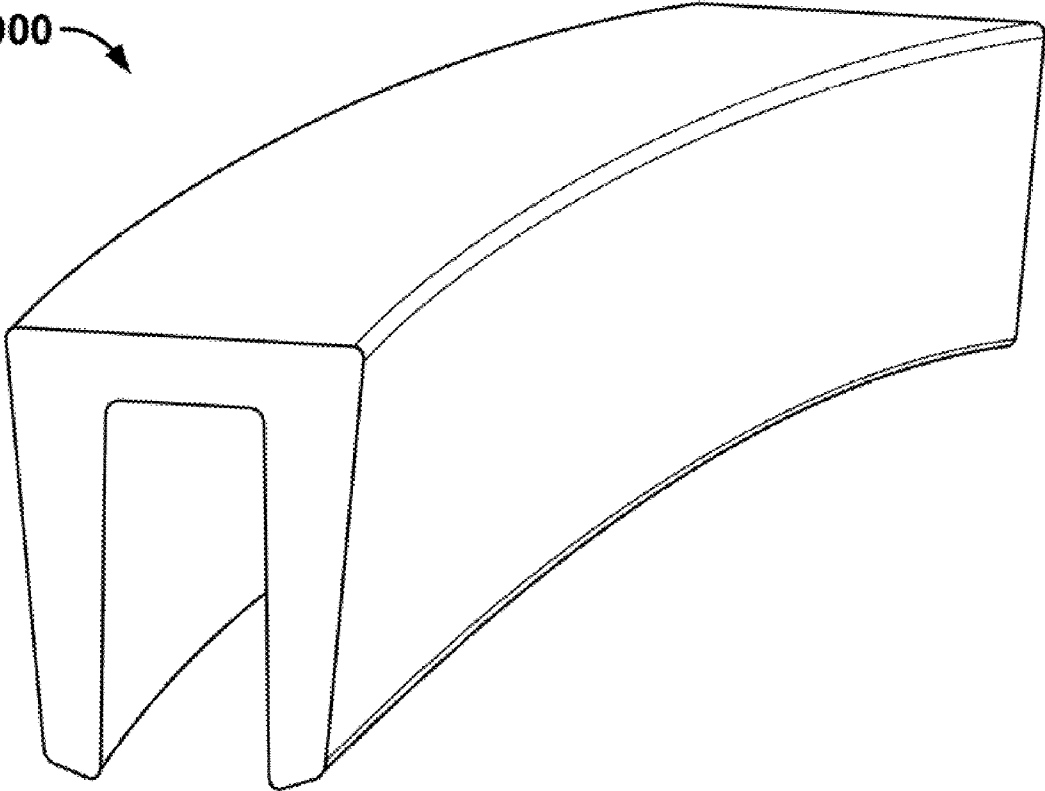
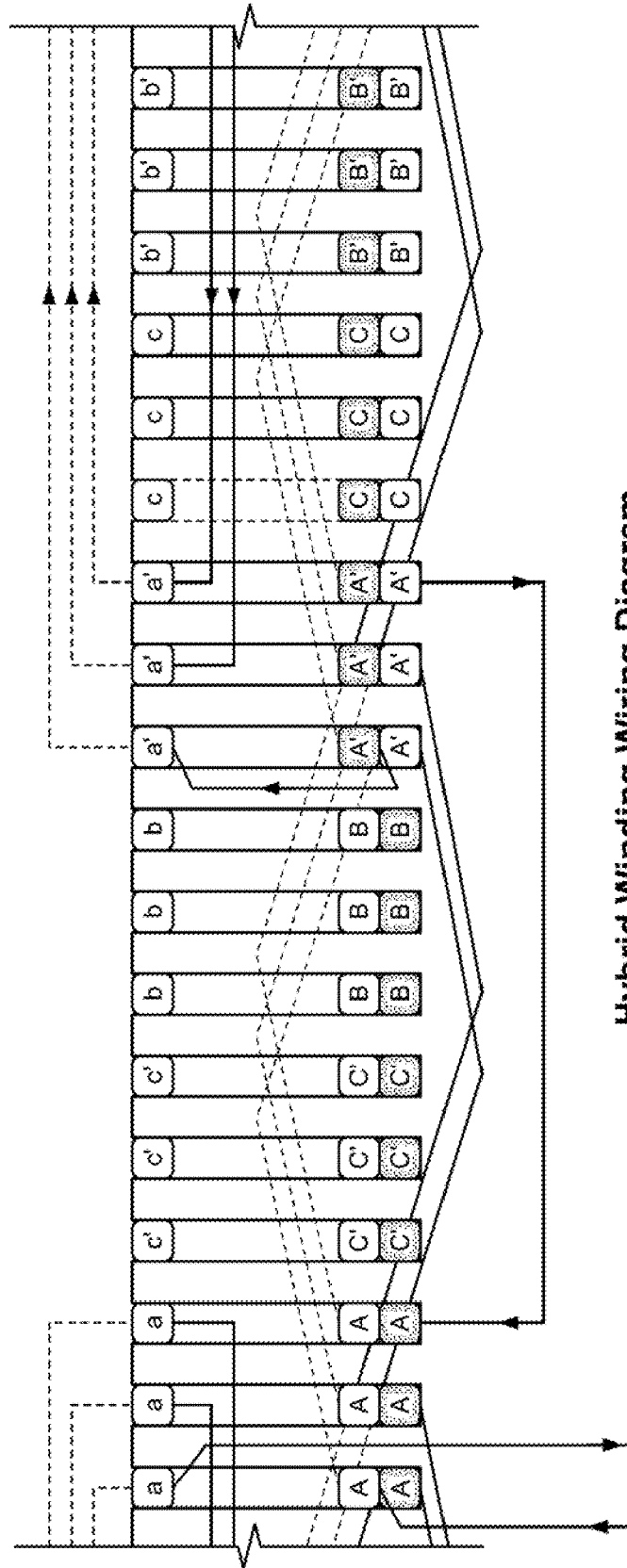
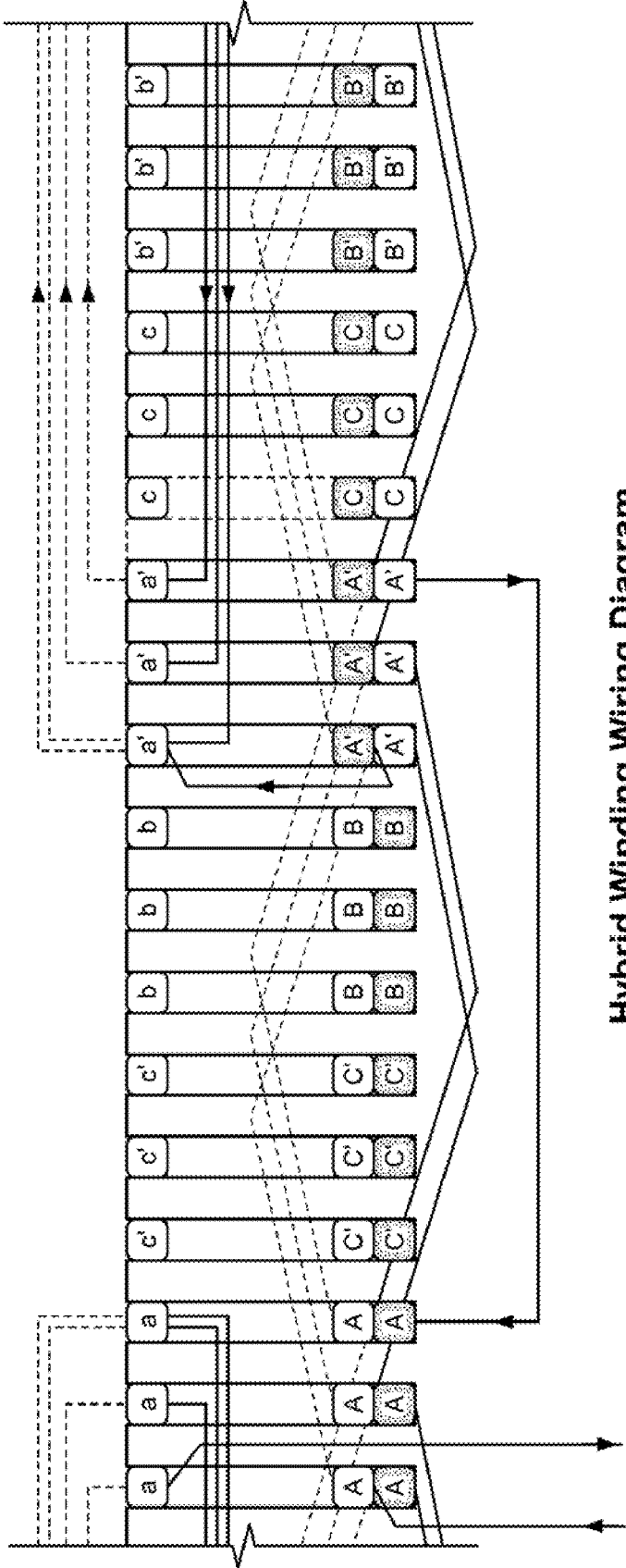

FIG. 4V



Hybrid Winding Wiring Diagram
Showing Connections for One Phase
"1-1-1" Concentric Coils

FIG. 4W



Hybrid Winding Wiring Diagram
Showing Connections for One Phase
"2-1-1" Concentric Coils

FIG. 4X

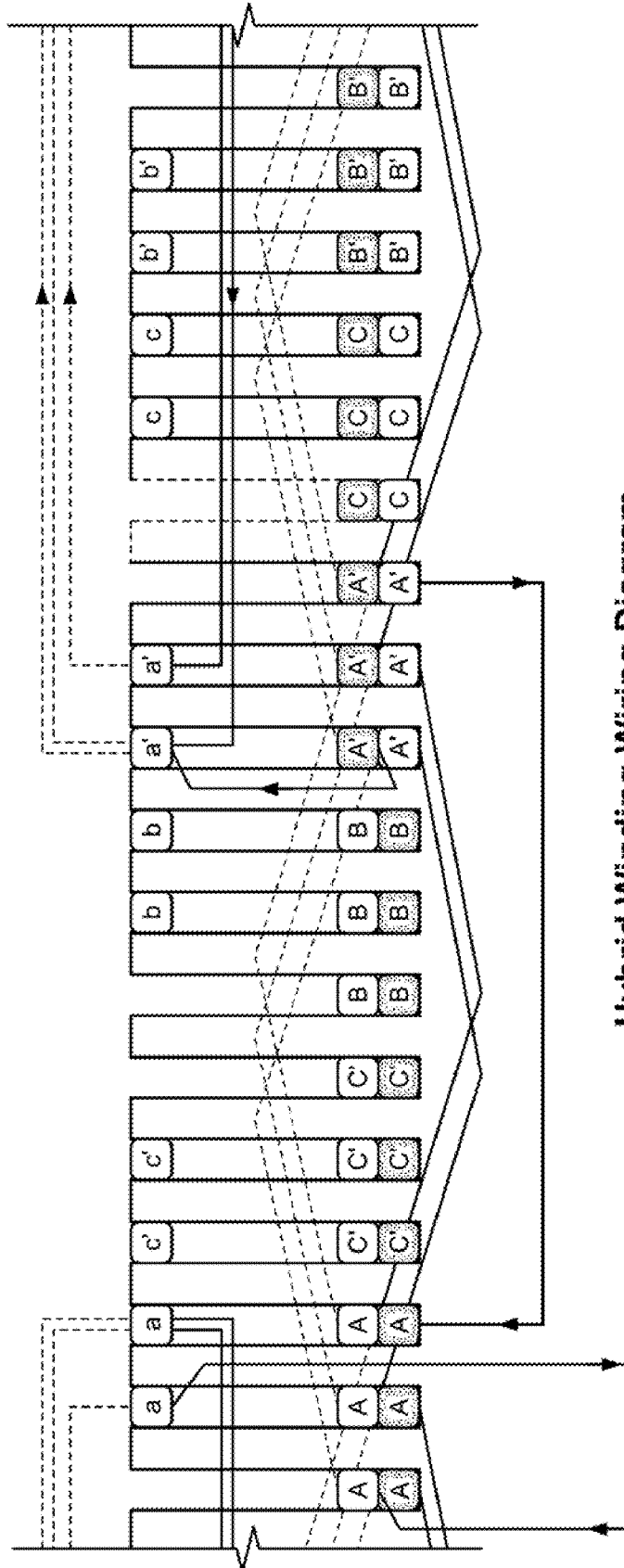

Hybrid Winding Wiring Diagram
Showing Connections for One Phase
"2-1-0" Concentric Coils

FIG. 4Y

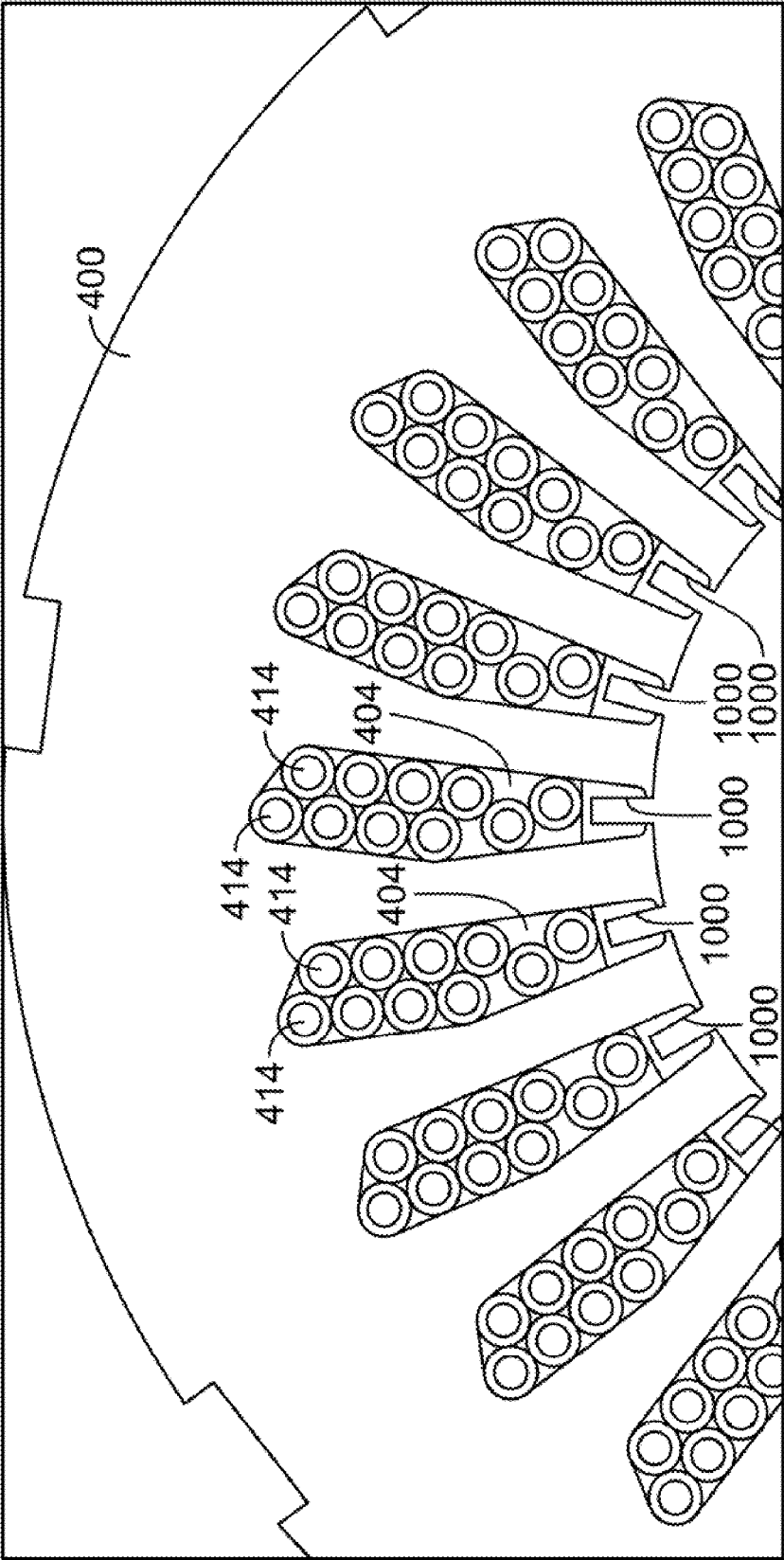

FIG. 4Z

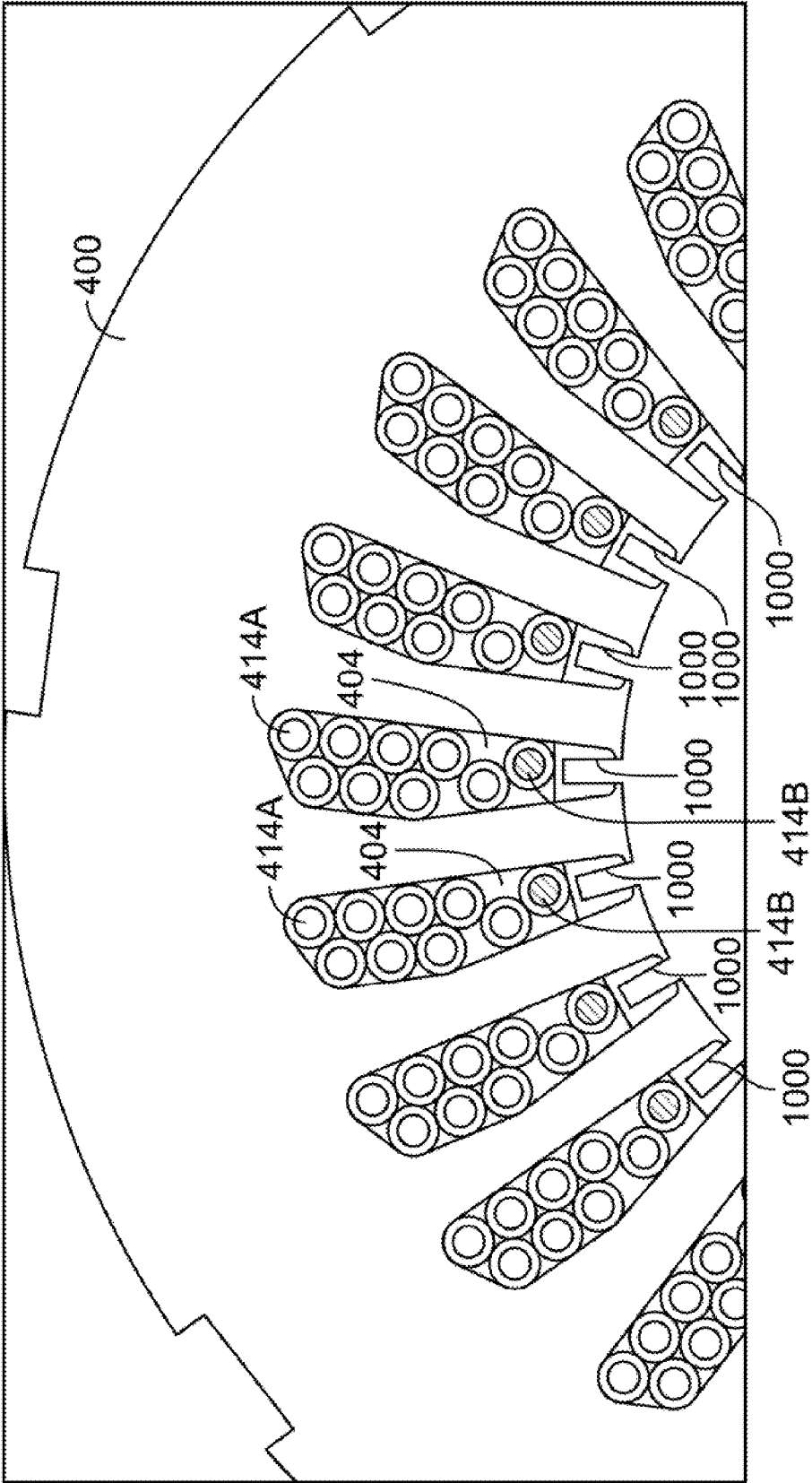

FIG. 4AA

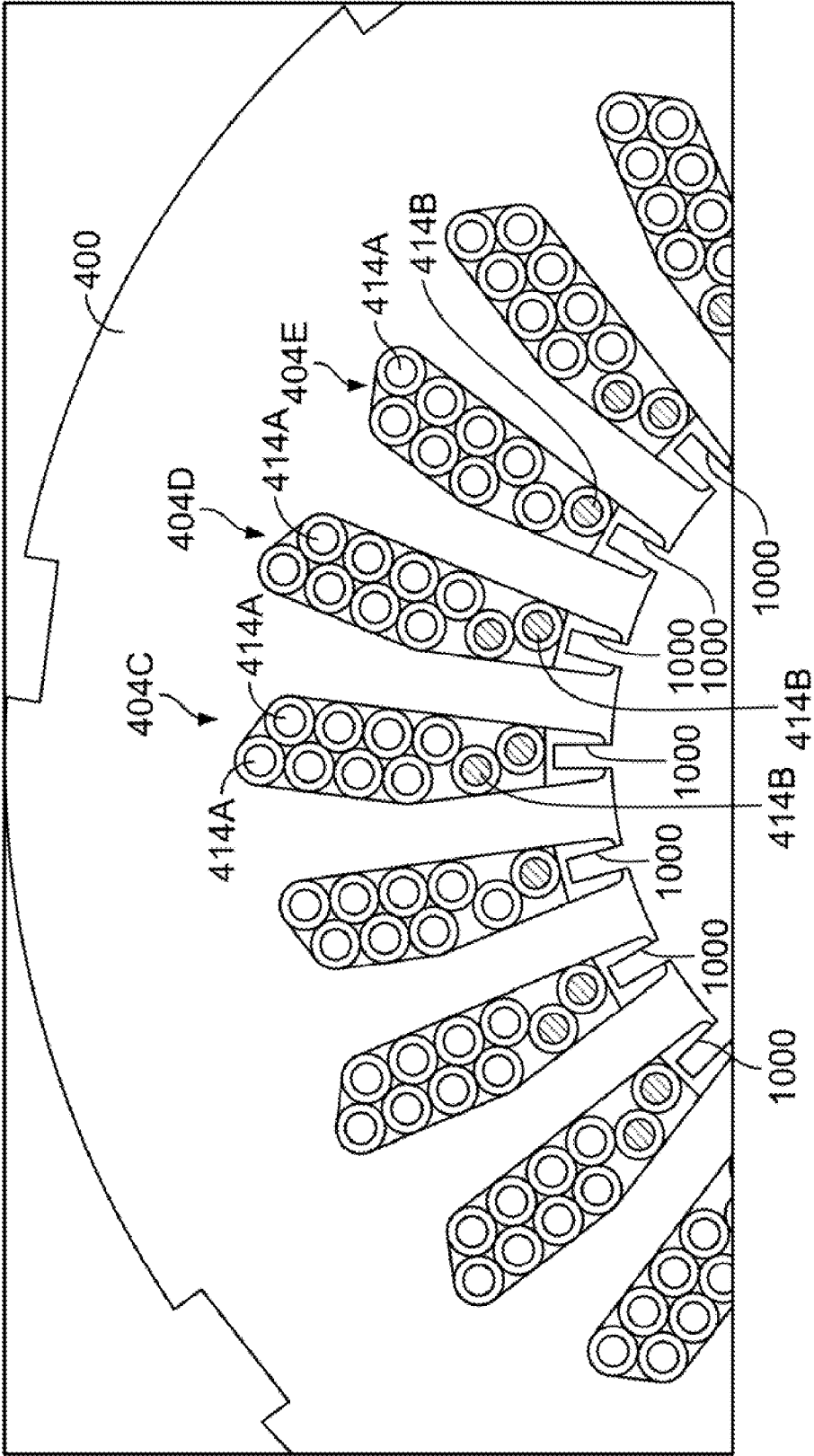

FIG. 4BB

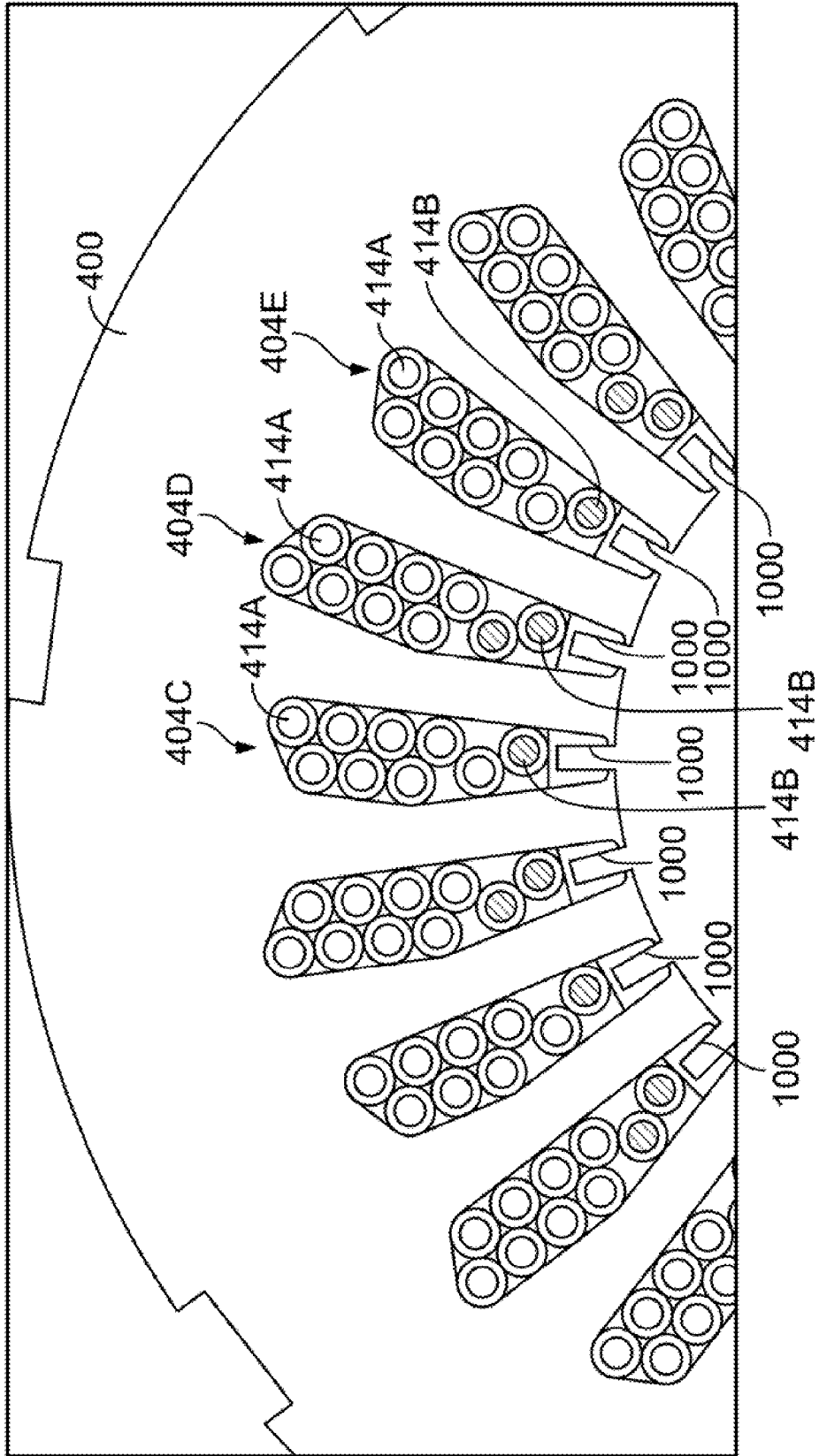

FIG. 4CC

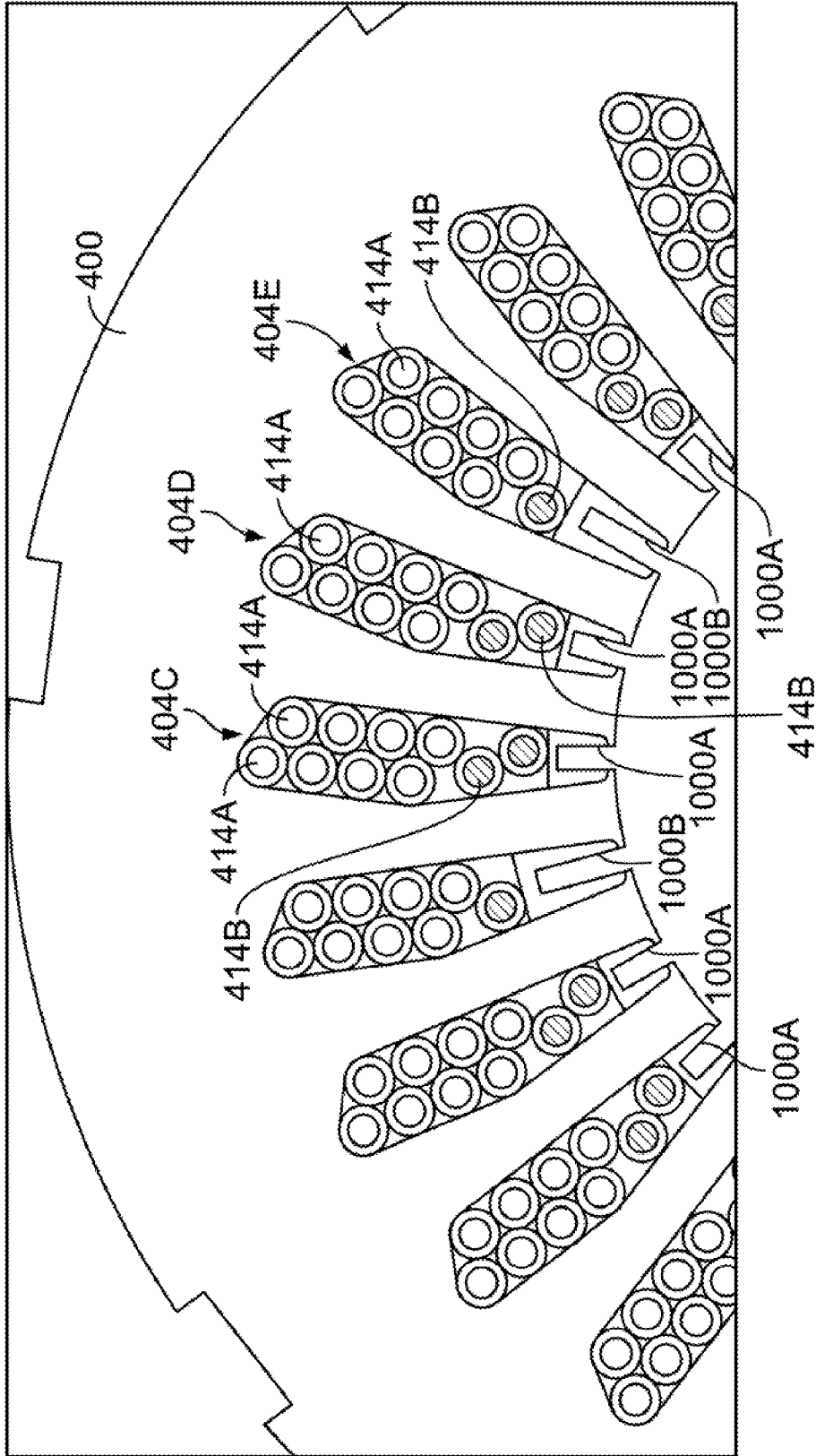

FIG. 4DD

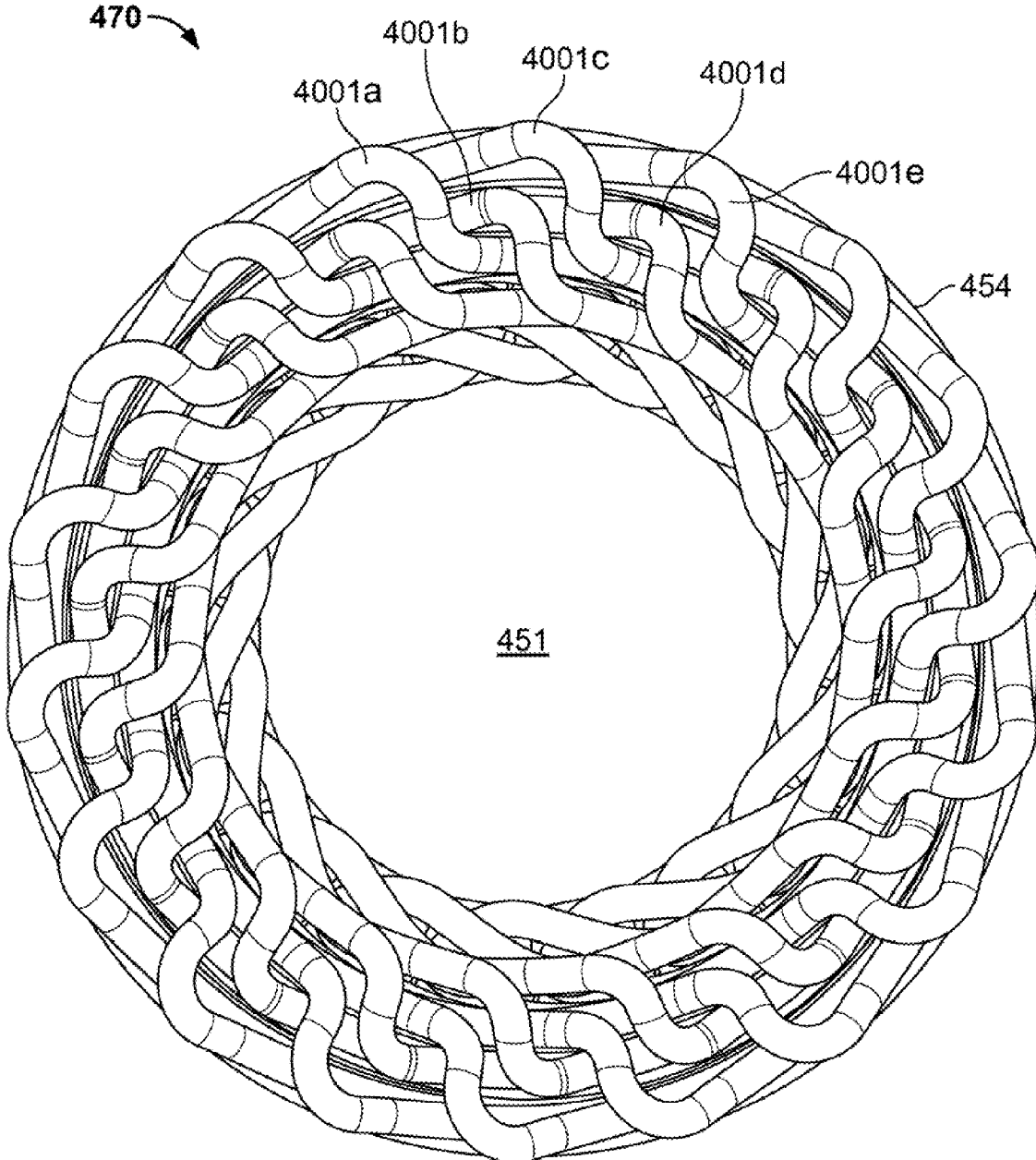

FIG. 4EE

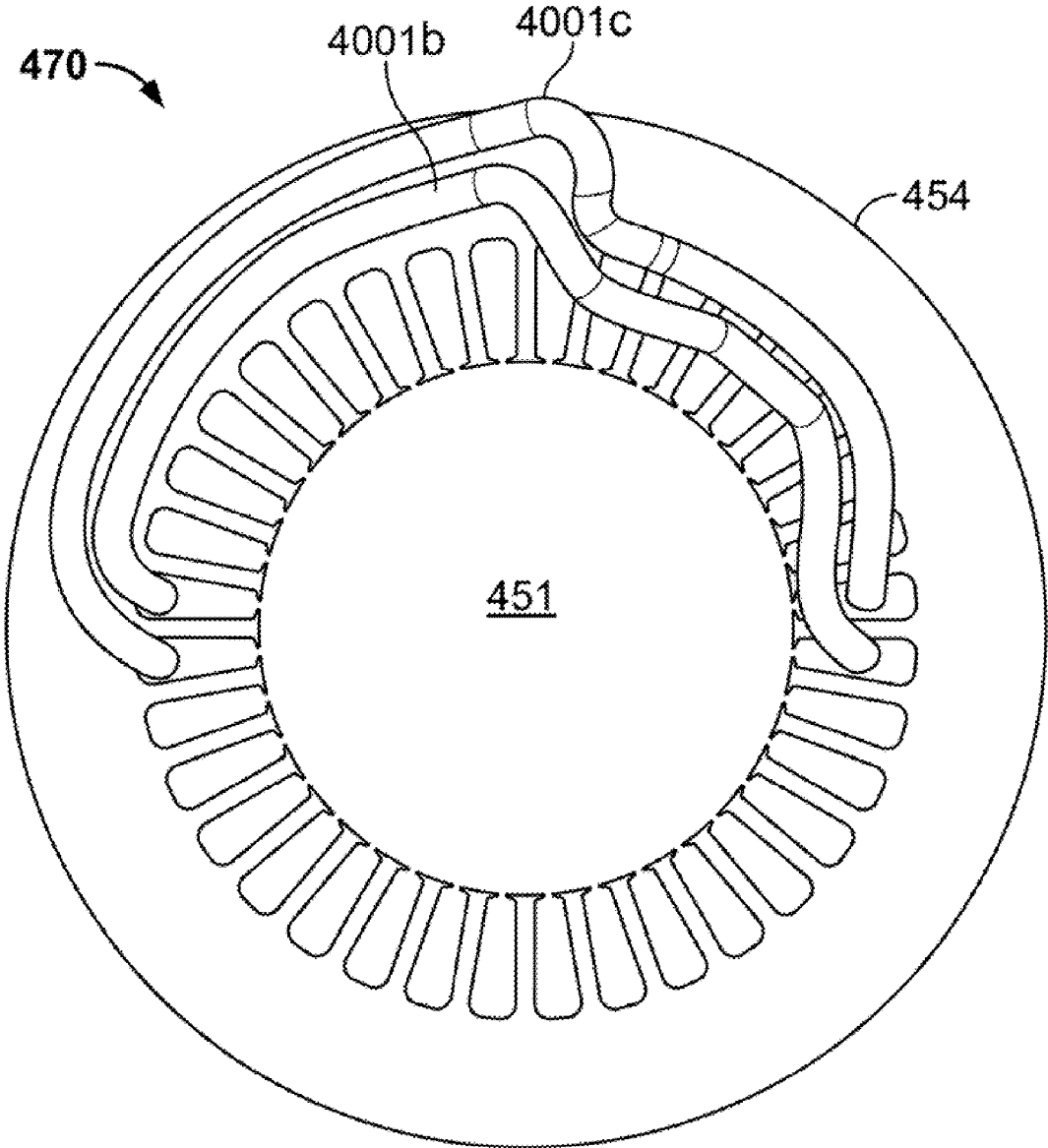

FIG. 4FF

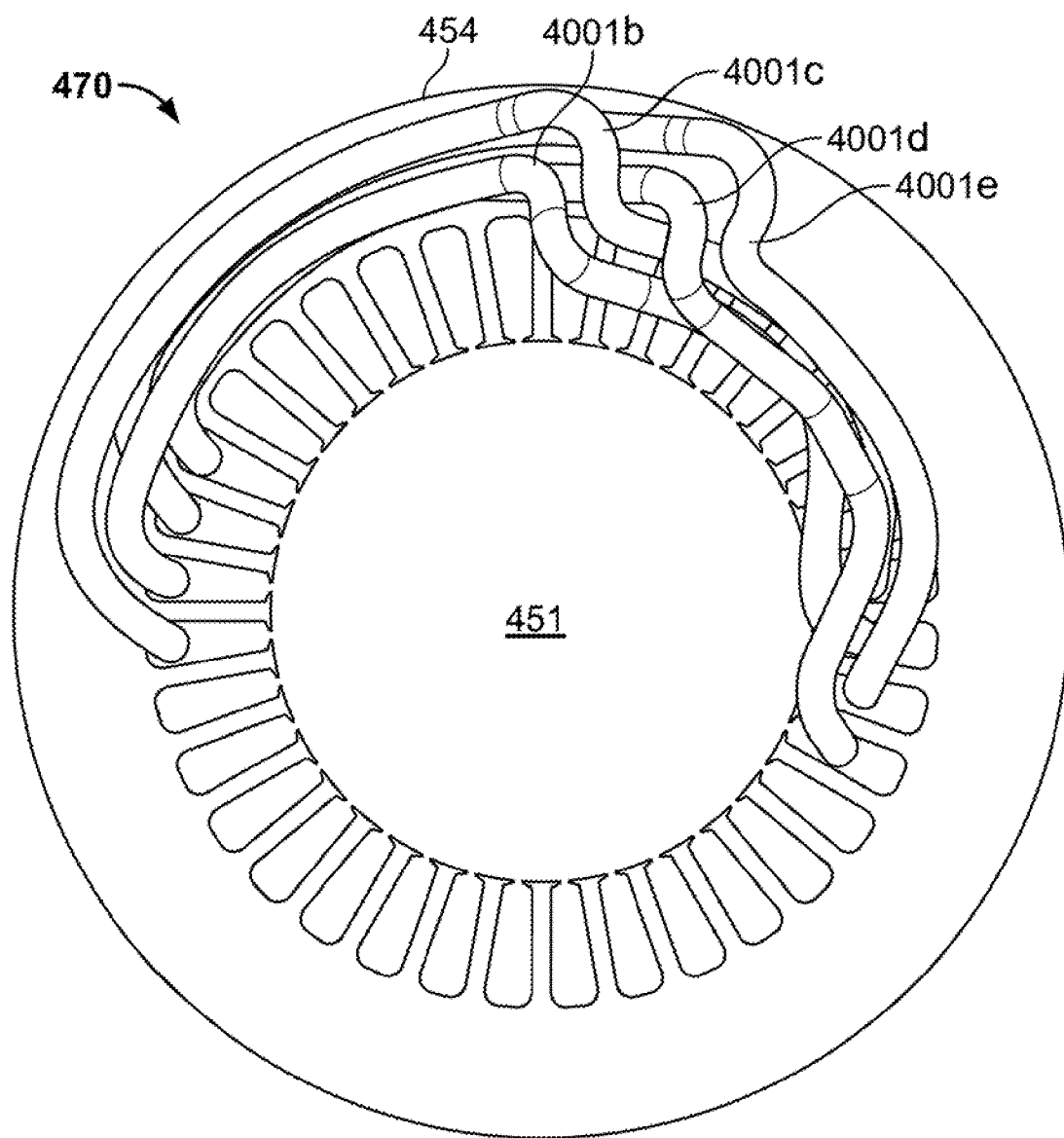

FIG. 4GG

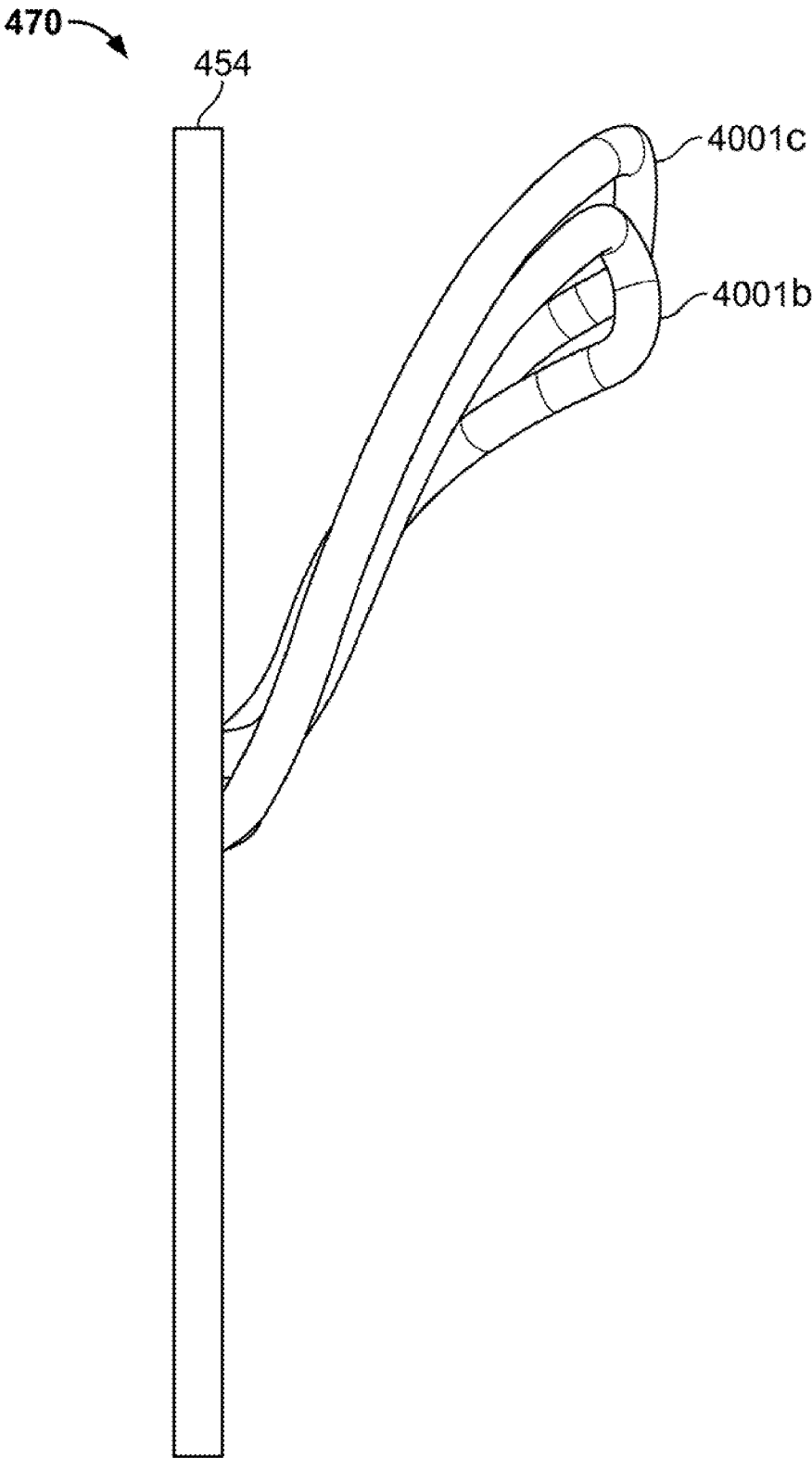

FIG. 4HH

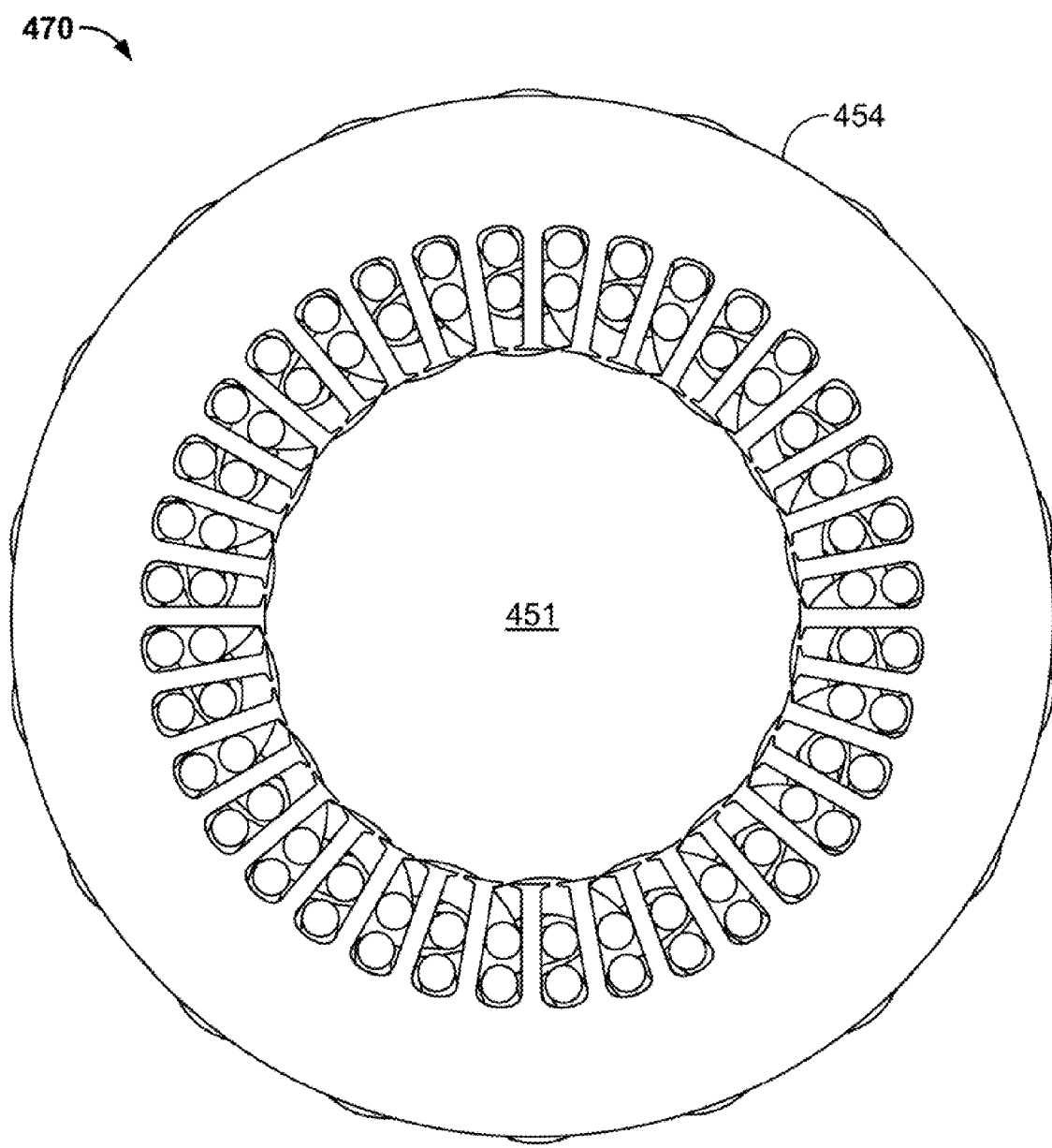

FIG. 4II

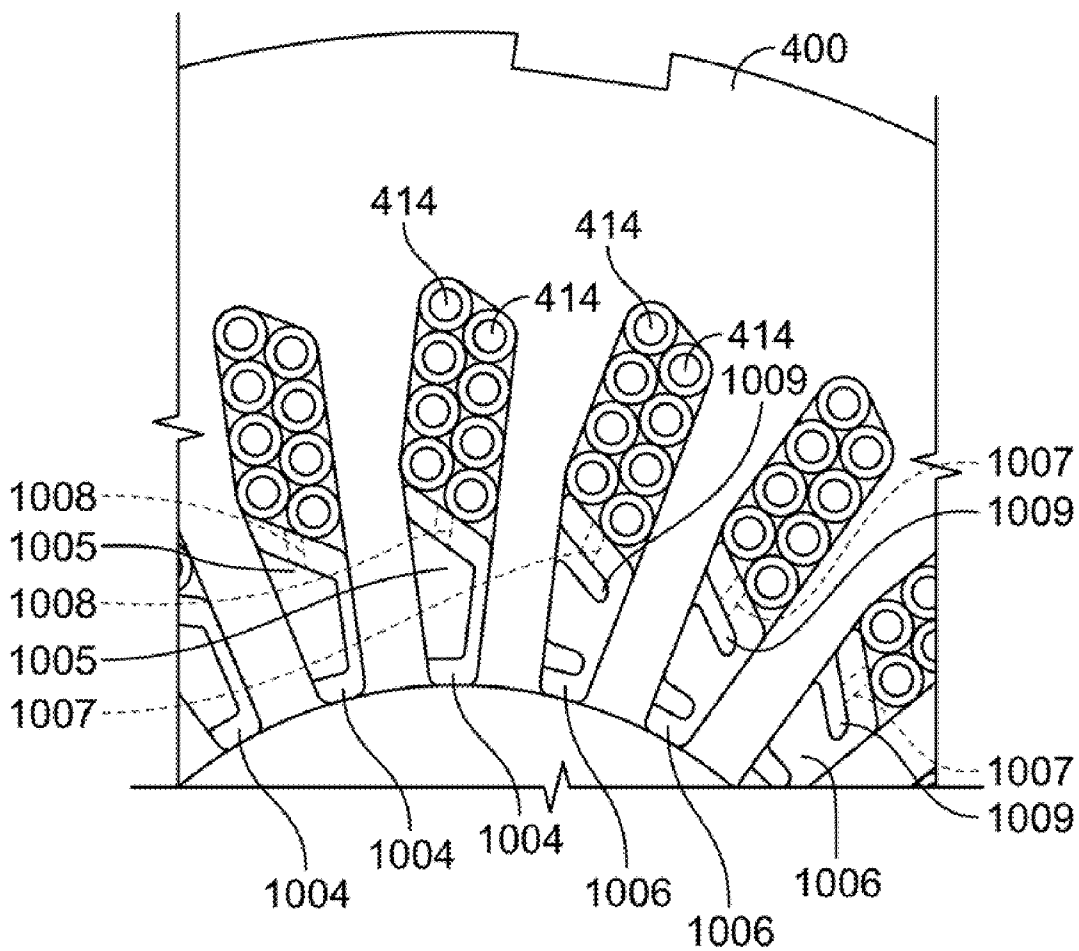

FIG. 4JJ

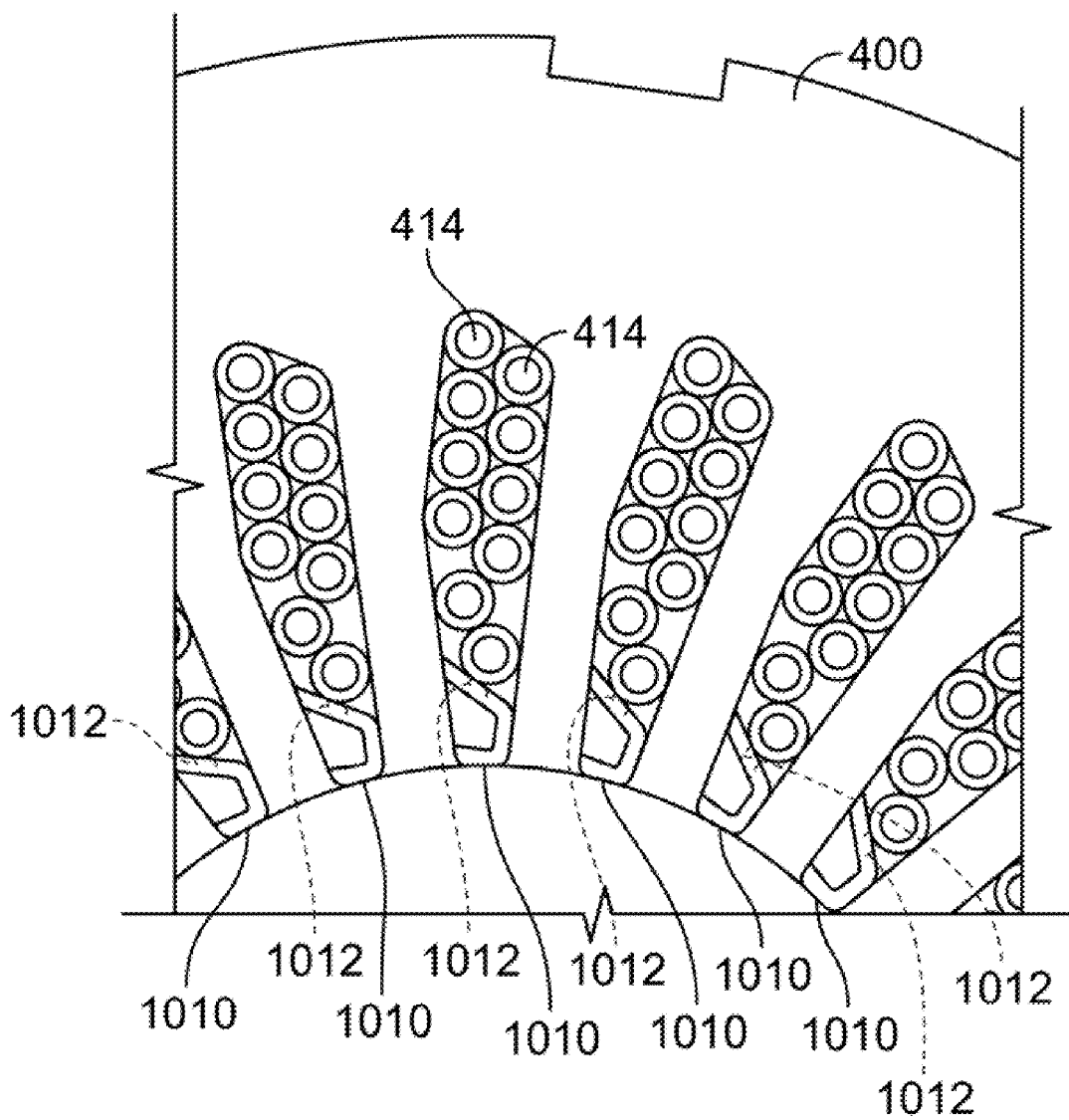

FIG. 4KK

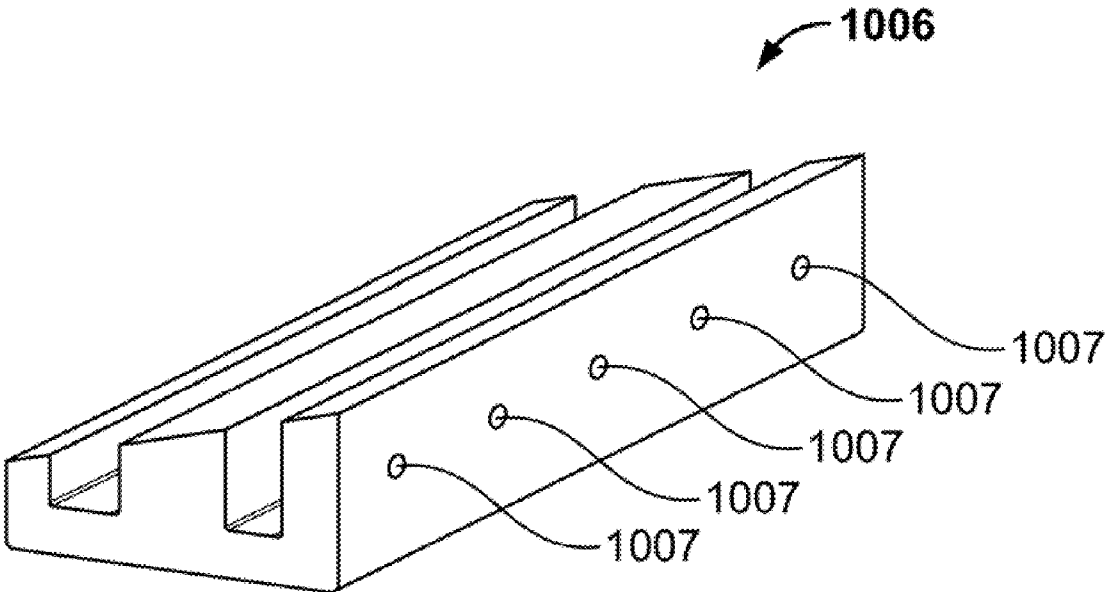

FIG. 4LL

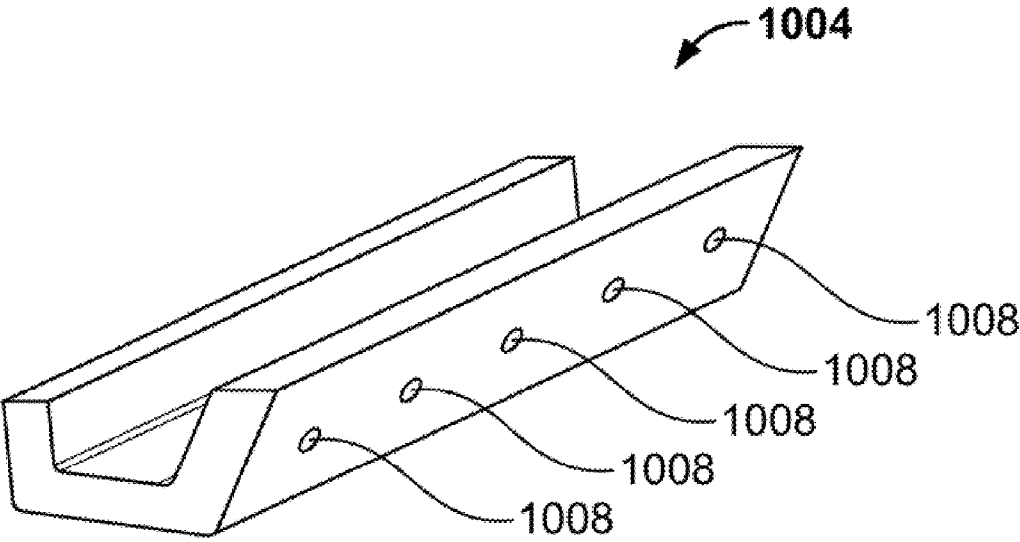

FIG. 4MM

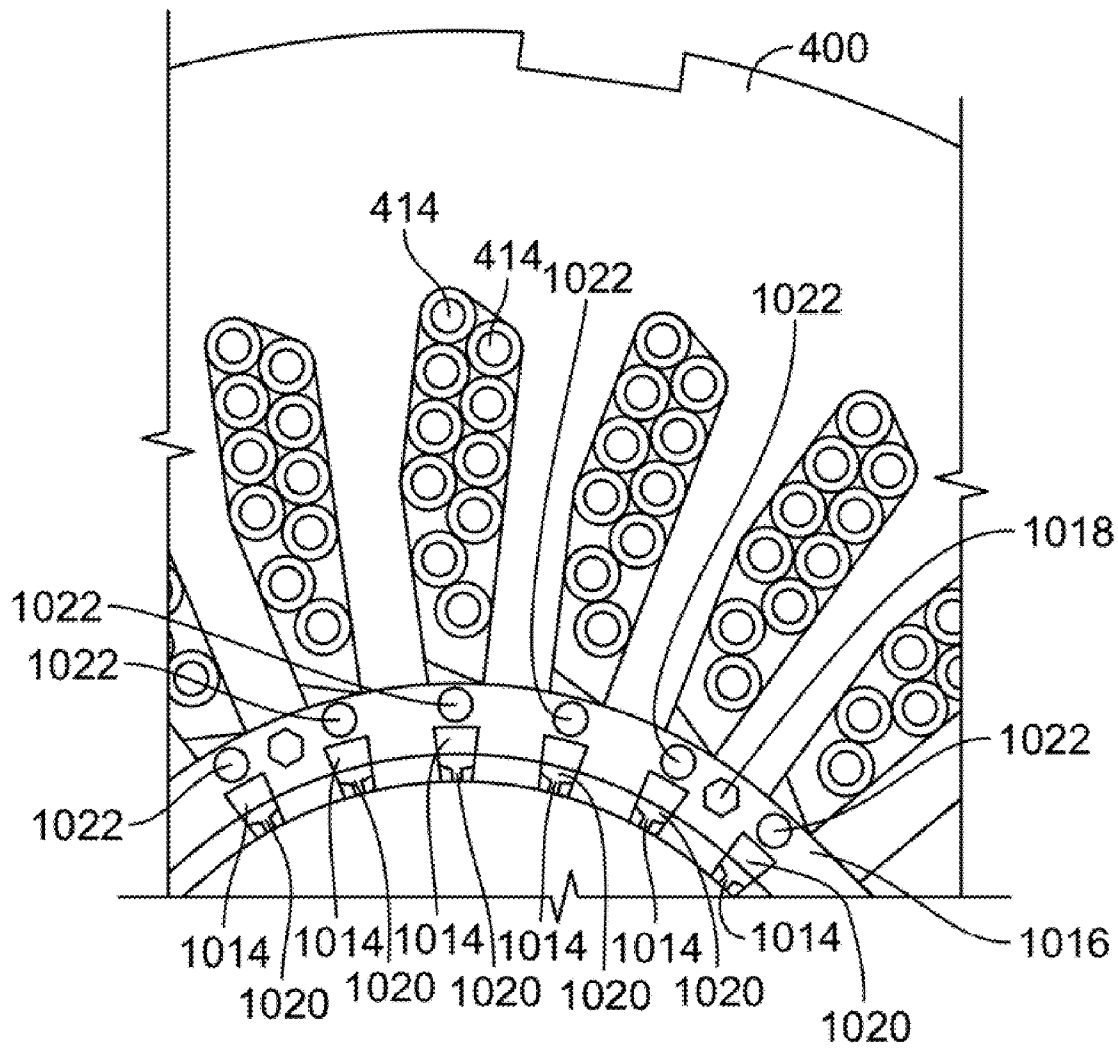

FIG. 4NN

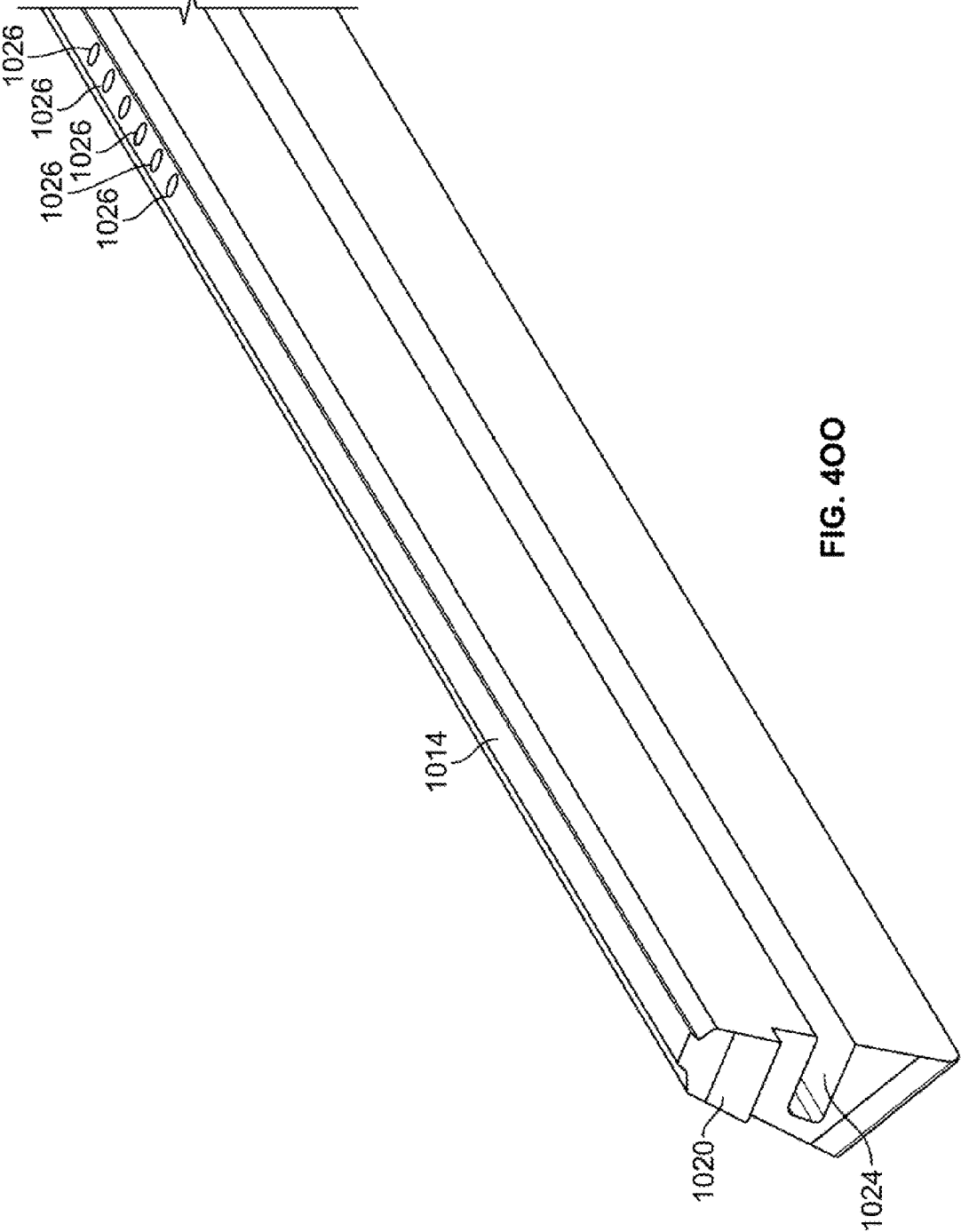

FIG. 400

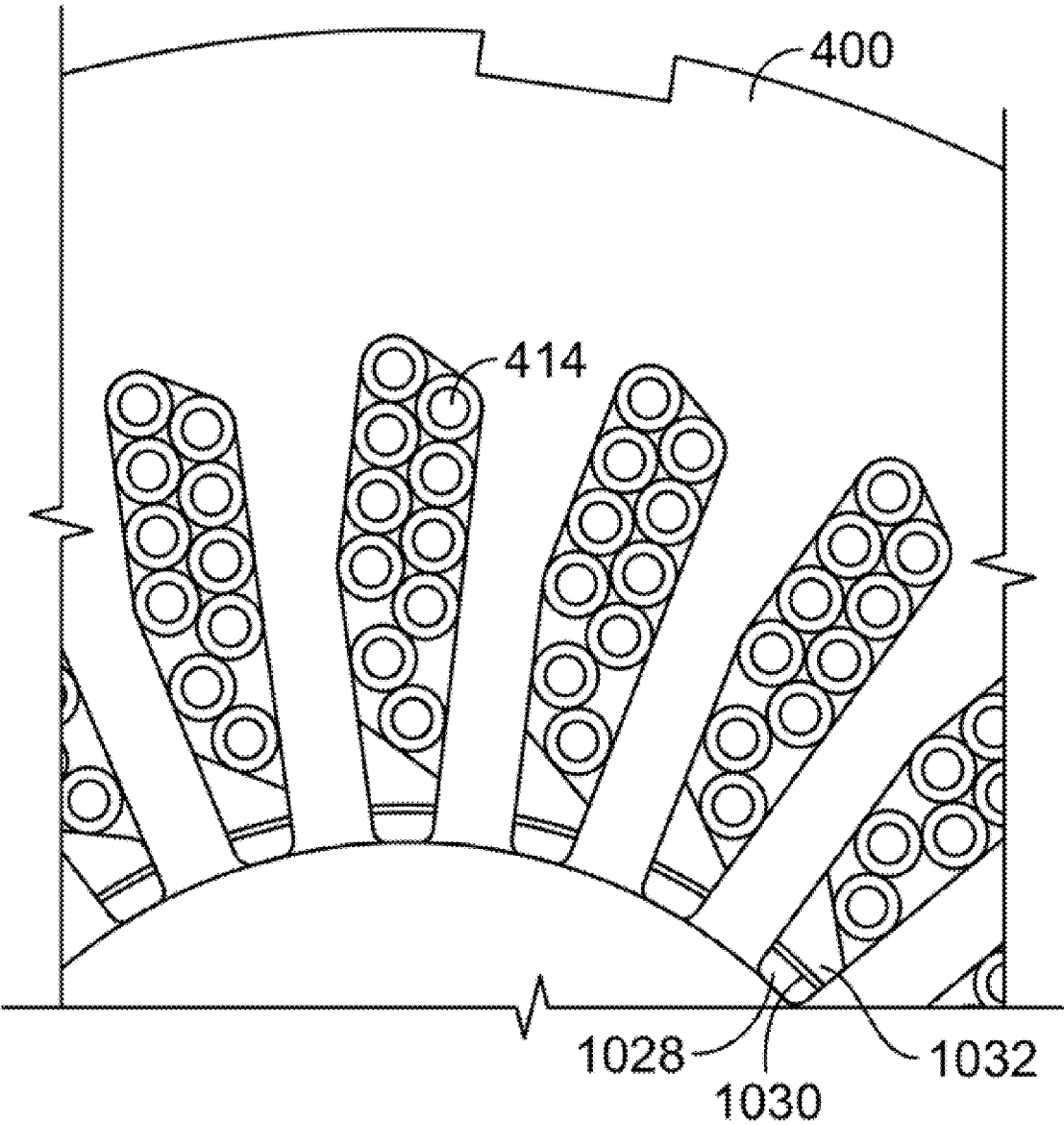

FIG. 4PP

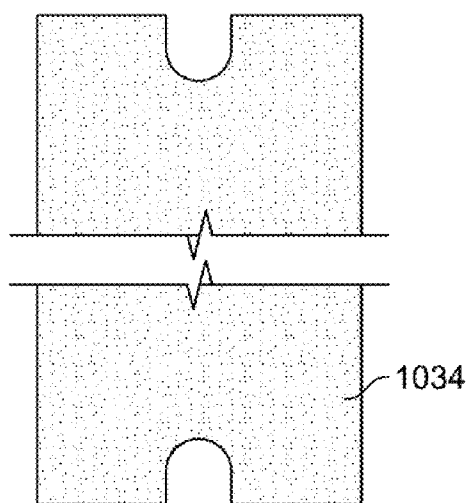

FIG. 4QQ

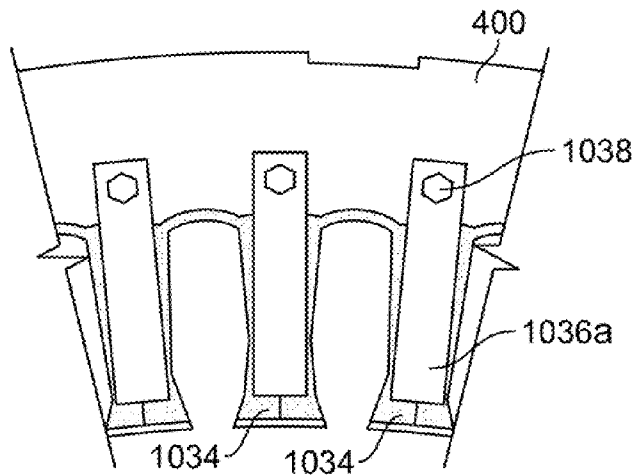

FIG. 4RR

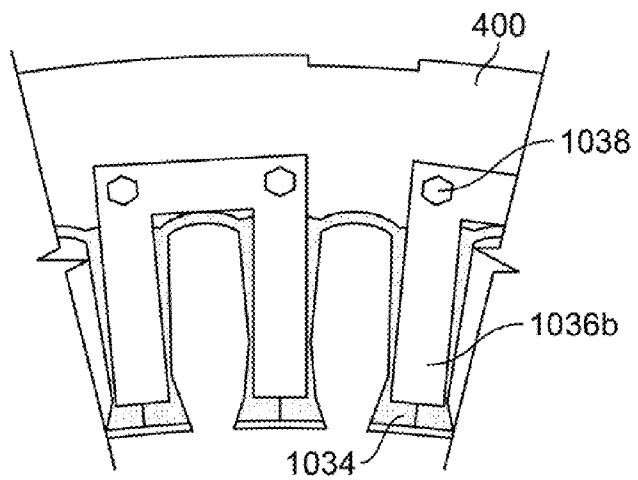

FIG. 4SS

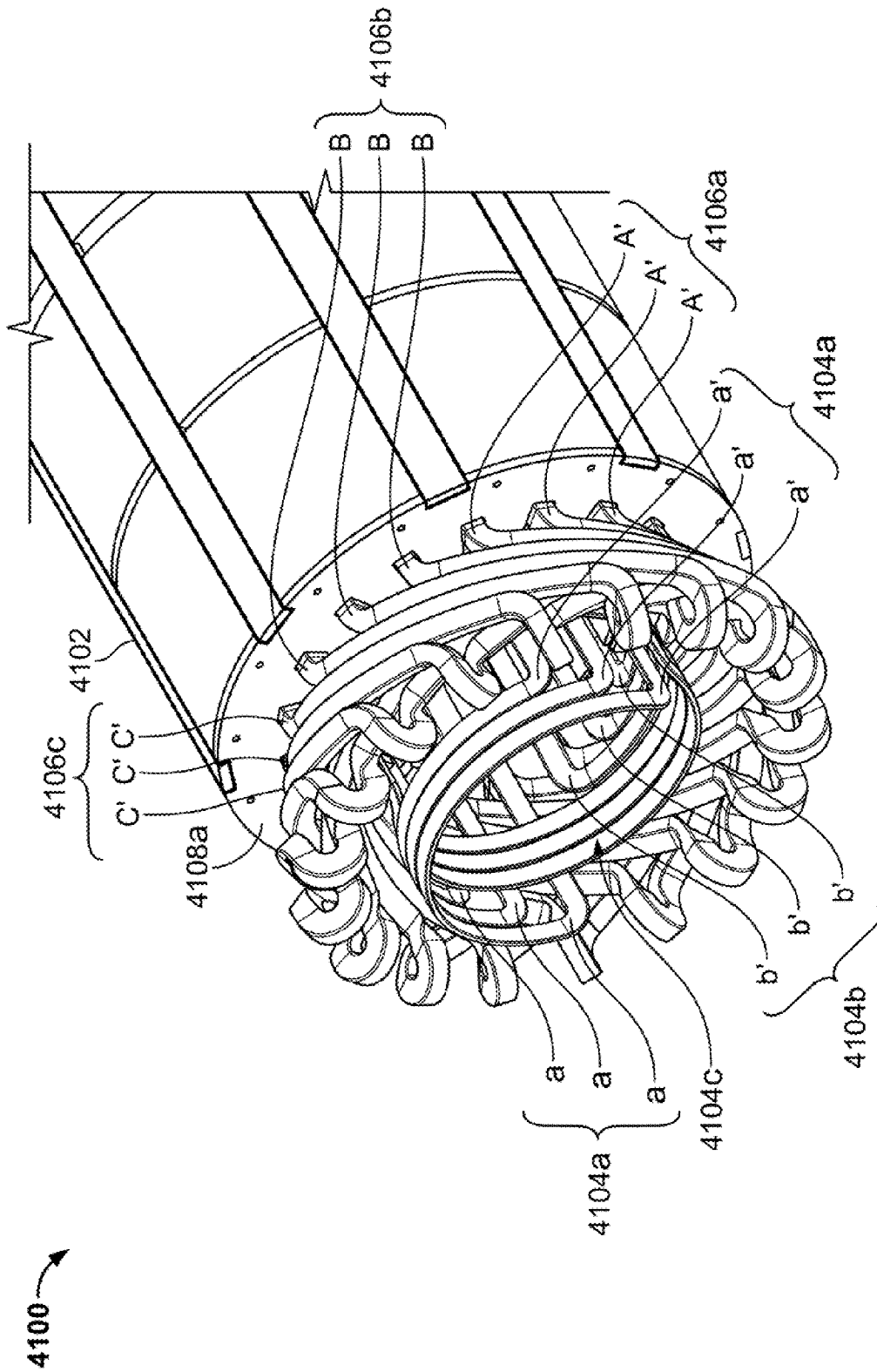

FIG. 4TT

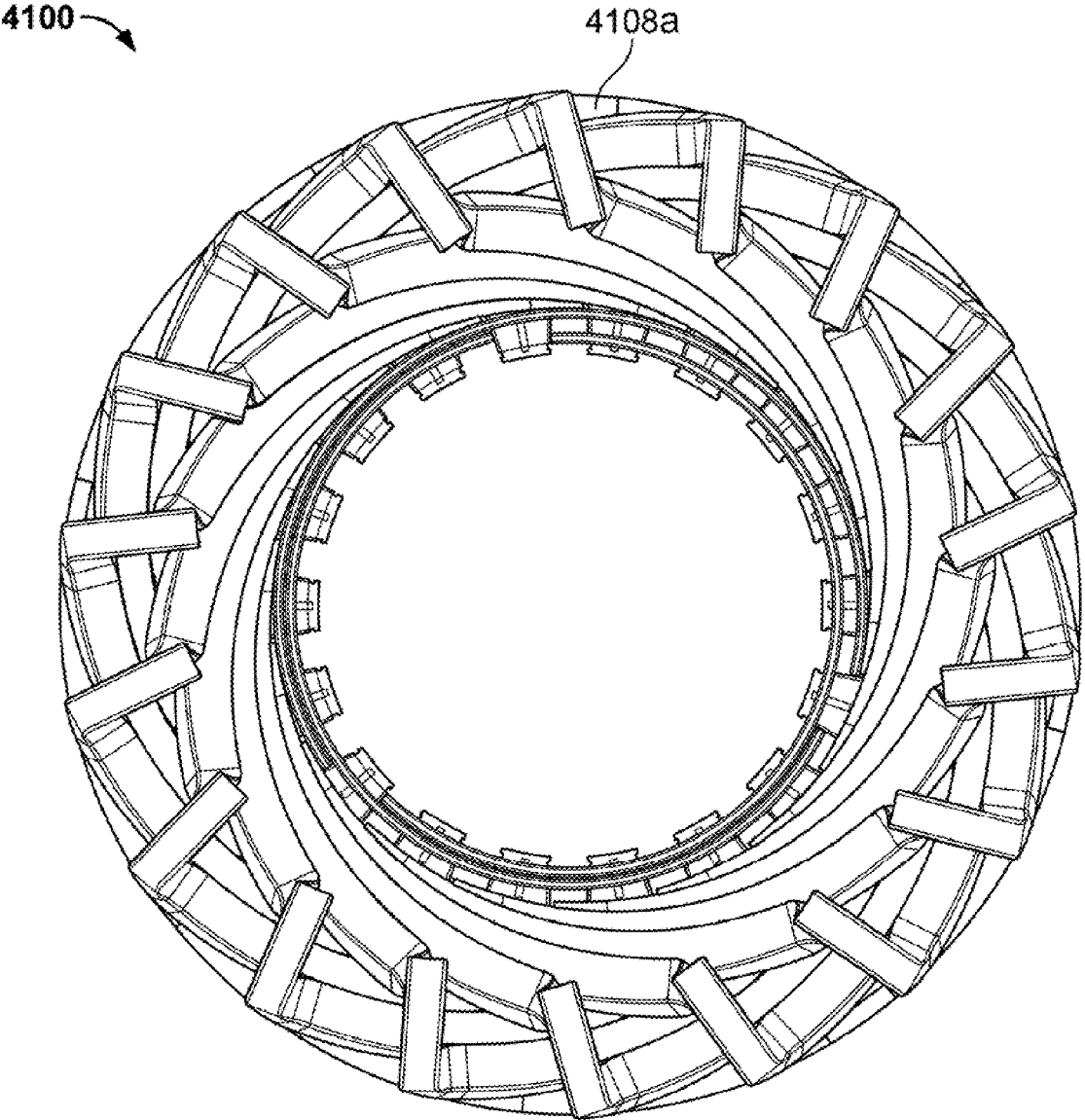

FIG. 4UU

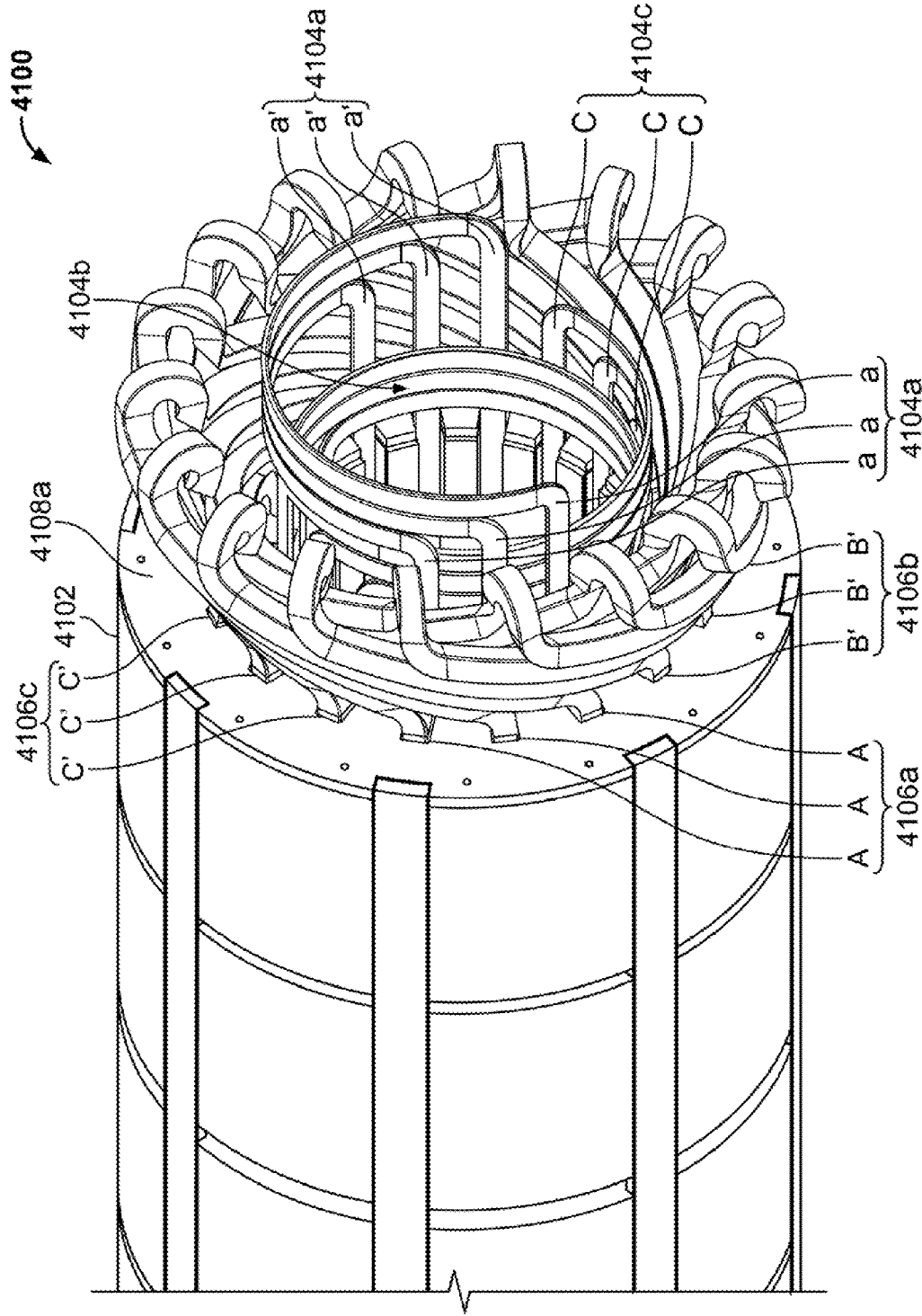

FIG. 4VV

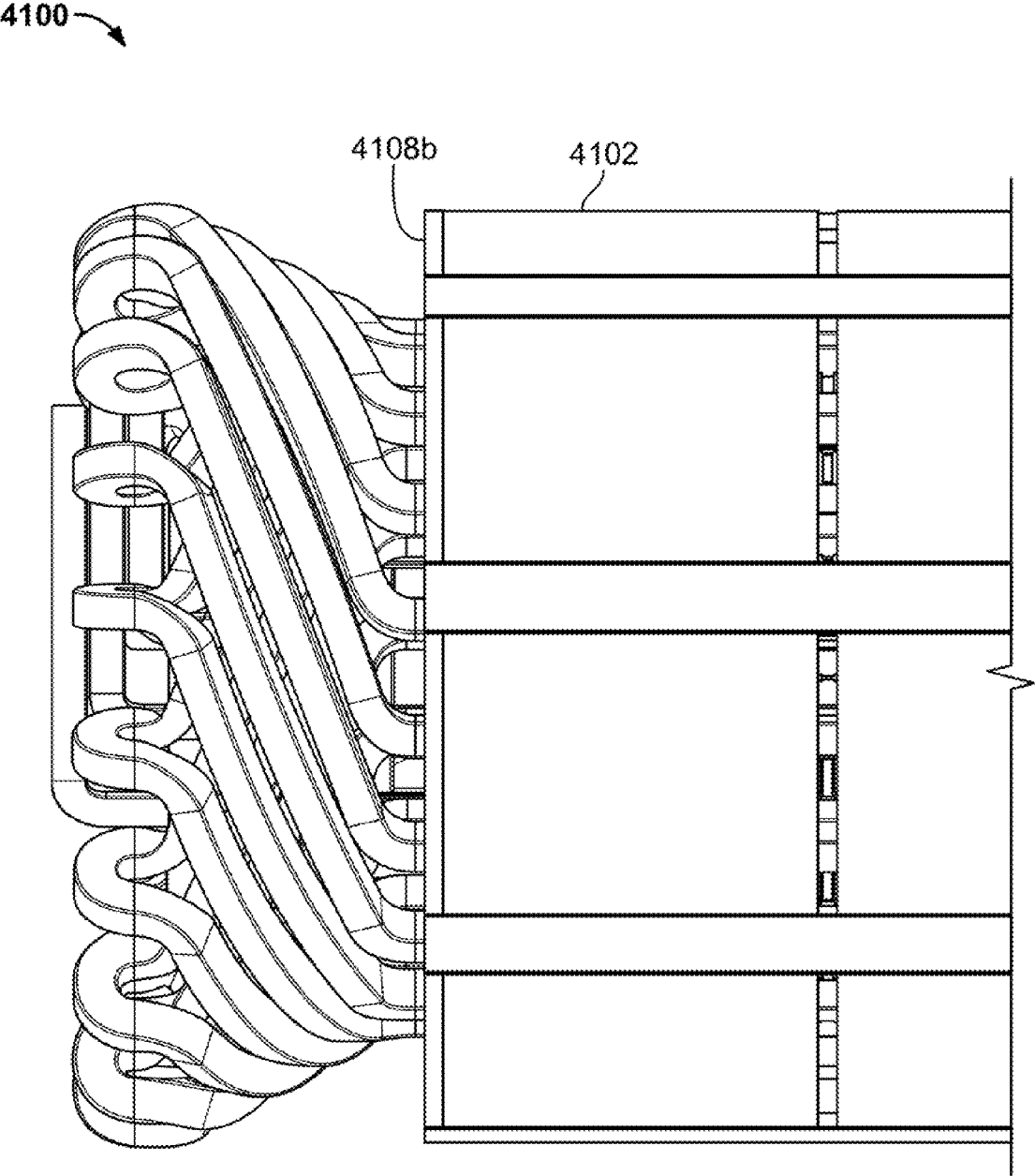

FIG. 4WW

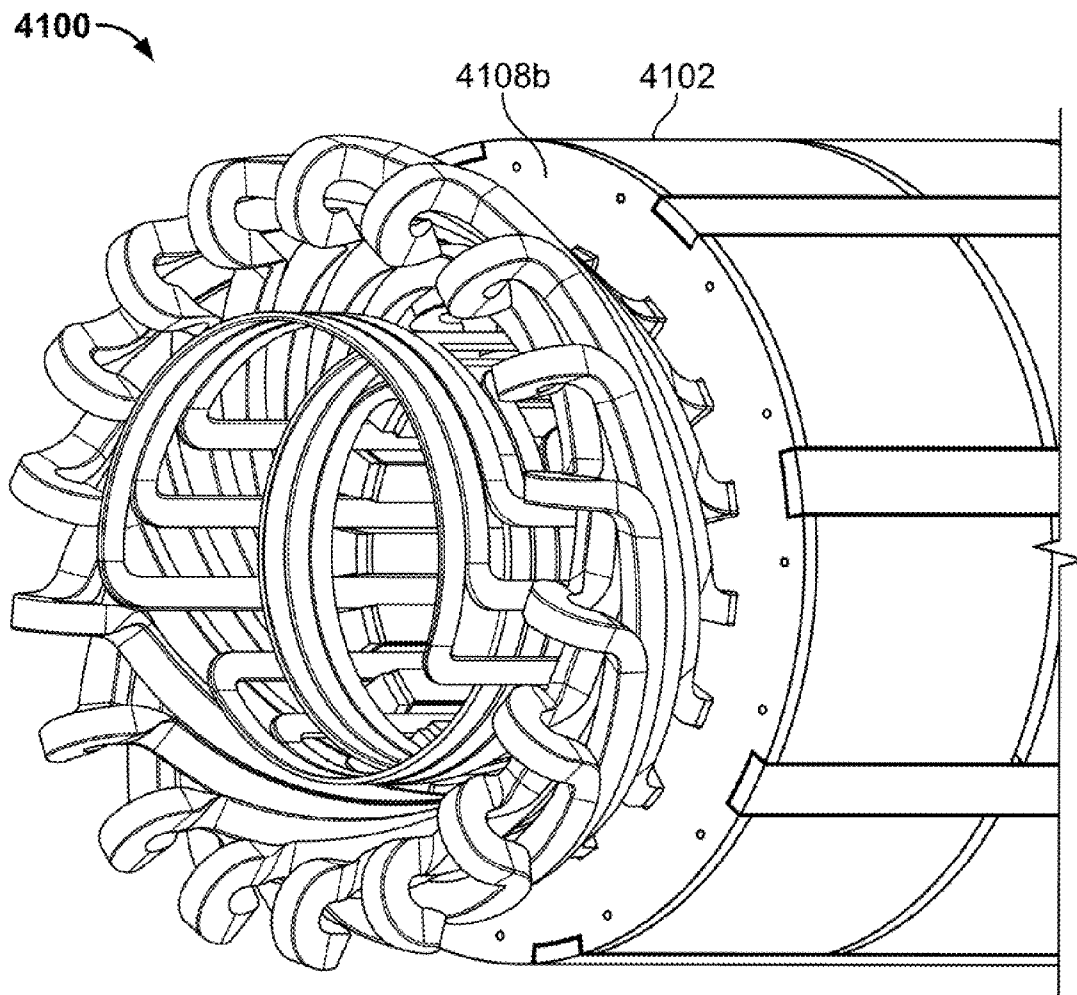

FIG. 4XX

END TURN CONFIGURATION OF AN ELECTRIC MACHINE

CROSS-REFERENCE TO RELATED APPLICATIONS

[0001] This application claims the benefit of U.S. Provisional Application No. 61/084,238, filed Jul. 28, 2008 and U.S. Provisional Application No. 61/096,290, filed Sep. 11, 2008, the entire disclosures of which are incorporated by reference herein.

BACKGROUND

[0002] Some electric machines operate to convert mechanical movement (e.g., kinetic energy) into electrical power, convert electrical power into mechanical movement, or both. For example, an electric machine system that operates to convert mechanical movement into electrical power (i.e., generate electrical power) can include an electric machine coupled to a companion device that is a prime mover. The prime mover supplies mechanical movement to the electric machine, which converts the mechanical movement into electrical power. An electric machine system configured to convert electrical power into mechanical movement (i.e., motor) can include an electric machine coupled to a companion device that is driven by the mechanical movement output from the electric machine. In certain instances, electric machine systems configured to both generate electrical power and mechanical movement can include an electric machine coupled to a companion device (e.g., a prime mover) that may be driven by the electric machine and that may drive the electric machine.

SUMMARY

[0003] A stator of an electric machine includes a core that carries conductive coils. The conductive coils form four layers of end turns axially external the core.

[0004] In one general aspect, a stator for an electric machine includes an elongate core having an end face and an opposing end face, the elongate core adapted to internally receive a rotor of an electric machine. The stator includes multiple conductive coils. Each coil defines a loop that extends axially through the elongate core, exits the core through the end face, and reenters the core through the end face. A first subset of the coils collectively form a first radial layer axially exterior the core and a third radial layer axially exterior the core. Each coil in the first subset resides in both the first layer and the third layer. A second subset of the coils collectively forms a second radial layer axially exterior the core and a fourth radial layer axially exterior the core. Each coil in the second subset residing in both the second layer and the fourth layer. The second layer resides radially between the first and third layers. The third layer resides radially between the second and fourth layers.

[0005] In another general aspect, a stator for an electric machine includes an elongate core adapted to internally receive a rotor of an electric machine. The stator includes a first set of coils and a second set of coils. The first set of coils are arranged in a first lap winding configuration. The first set of coils form a first set of end turns that each extend through a first radial layer of end turns and a third radial layer of end turns. A second set of coils are arranged in a second lap winding configuration. The second set of coils form a second plurality of end turns that each extend through a second radial

layer of end turns and a fourth radial layer of end turns. The second layer resides radially between the first and third radial layers. The third layer resides radially between the second and fourth radial layers.

[0006] In another general aspect, a first set of coils are installed in a core of a stator. The first plurality of coils collectively form a first radial layer of end turns and a third radial layer of end turns axially external the core. Each coil in the first set defines a loop that extends axially through the core, exits the core through the end face, extends through the first radial layer, extends through the third radial layer, and reenters the core through the end face. A second set of coils are installed in the core of the stator. The second set of coils collectively form a second radial layer of end turns and a fourth radial layer of end turns axially external the core. Each coil in the second subset defines a loop that extends axially through the core, exits the core through the end face, extends through the second radial layer, extends through the fourth radial layer, and reenters the core through the end face. The second radial layer resides radially between the first and third radial layers, and the third layer resides radially between the second and fourth radial layers.

[0007] Implementations may include one or more of the following features. The loop defined by each coil in the first subset exits the core through the end face at an exit location in the first radial layer and reenters the core through the end face at a reentry location in the third radial layer. The loop defined by each coil in the second subset exits the core through the end face at an exit location in the second radial layer, and reenters the core through the end face at a reentry location in the fourth radial layer. The first and second sets of coils form two radial layers in the elongate core, and each of the coils resides in both radial layers in the elongate core. The two radial layers in the elongate core define two radii including a second radius that coincides with the second radial layer of end turns and a third radius that coincides with the third radial layers of end turns. The loop defined by each coil in the first subset exits the core through the end face at an exit location on the second radius, turns toward the first radial layer, extends through the first radial layer, turns toward the third radial layer, extends through the third radial layer, and reenters the end face at its reentry location on the third radius. The loop defined by each coil in the second subset exits the core through the end face at an exit location on the second radius, extends through the second radial layer, turns toward the fourth radial layer, extends through the fourth radial layer, turns toward the third radius, and reenters the end face at its reentry location on the third radius. The core defines slots to carry the coils. A first subset of the slots each carry two of the first subset of coils. A second subset of the slots each carry two of the second subset of coils. A radial distance between two coils in each slot and an azimuthal distance between two sides of the slot define a gap in the slot. The fourth radial layer is an inner-most radial layer, and the first radial layer is an outer-most radial layer. The first subset of slots have a first radial depth, and the second subset of slots have a second radial depth. The second radial depth is less than the first radial depth. The first subset of slots and the second subset of slots all have substantially equal radial depths. The first plurality of coils are coupled to the second plurality of coils to form a three-phase conductive winding. The electric machine is operated as a two-pole electric machine or a four-pole electric machine. Installing the first plurality of coils and/or the second plurality of coils includes forming a winding structure outside of the core and

installing the formed winding structure in the core. Installing the first plurality of coils and/or the second plurality of coils includes installing each of the plurality of coils by successively forming individual turns of the coil in the core of the stator. Installing the first plurality of coils and installing the second plurality of coils can include simultaneously or substantially simultaneously installing the first plurality of coils and the second plurality of coils.

[0008] The details of one or more implementations are set forth in the accompanying drawings and the description below. Other features, objects, and advantages will be apparent from the description and drawings, and from the claims.

DESCRIPTION OF DRAWINGS

[0009] FIG. 1A is a schematic of an example electric machine system.

[0010] FIG. 1B is a cross-sectional view of an example electric machine system including a subsea pump.

[0011] FIG. 1C is a cross-sectional view of an example electric machine system including a subsea compressor.

[0012] FIG. 2A is a cross-sectional view of an example rotor.

[0013] FIG. 2B is a detail cross-sectional view of an end of the example rotor of FIG. 2A.

[0014] FIG. 2C shows an example rotor with a composite sleeve formed by a metallic tape wrapped around an outer jacket of the rotor.

[0015] FIG. 2D is a detail cross-sectional view of an end of an example rotor having a rotor sleeve formed from a metal alloy tape.

[0016] FIG. 2E is a detail cut-away view of an example rotor sleeve.

[0017] FIG. 2F is a detail cross-sectional view of another example rotor.

[0018] FIG. 2G is a detail, perspective view of the example rotor of FIG. 2E.

[0019] FIGS. 2H-2P are schematic cross-sectional views of different example rotors having segmented magnets, wherein the arrows associated with each magnet segment represent the respective magnet segment's north pole orientation.

[0020] FIG. 2Q is a side view of an example rotor showing a plurality of flow path channels formed by segments of the rotor magnets.

[0021] FIG. 2R is a side view of another example rotor having grooves formed in the rotor to facilitate introduction of a filler material thereinto.

[0022] FIG. 2S is a side view of another example rotor having an annular channel 264 formed therein along with an inlet formed in an end ring thereof.

[0023] FIG. 2T is a cross-sectional view of a magnet segment or magnet segment row having uniform radial magnetization.

[0024] FIG. 2U is a cross-sectional view of a magnet segment or magnet segment row having true radial magnetization.

[0025] FIG. 3A shows a cross-sectional view of an example electric machine.

[0026] FIG. 3B shows a perspective view of an example stator core for use in an electric machine.

[0027] FIG. 3C shows two adjacent yoke portions formed, each yoke portion formed from a plurality of individual portions.

[0028] FIG. 3D shows an example portion used to form part of the yoke portions of FIG. 3C.

[0029] FIG. 3E shows an example stator bar of the example stator of FIG. 3B used to provide alignment and rigidity to the stator.

[0030] FIG. 3F is an example end plate of the example stator of FIG. 3B.

[0031] FIG. 3G is a partial detail view of an end of the example stator of FIG. 3B.

[0032] FIG. 3H shows an example stator tooth lamination for use in the example stator of FIG. 3B.

[0033] FIG. 3I shows a side view of two adjacent stator tooth laminations having respective protrusions and receptacles for aligning and/or attaching the stator tooth laminations.

[0034] FIG. 3J shows an alternate configuration for aligning and/or attaching adjacent stator tooth laminations.

[0035] FIG. 3K is a schematic view of tooth segments disposed in a channel formed in adjacent yokes.

[0036] FIG. 3L is a cross-sectional view of an example electric machine having a protective barrier around the stator.

[0037] FIGS. 3M-3Q are partial cross-sectional views illustrating example constructions of the protective barrier.

[0038] FIG. 4A is a partial schematic end view of an example core of a stator for an electric machine.

[0039] FIG. 4B is a partial schematic end view of an example core of a stator for an electric machine.

[0040] FIG. 4C is a partial schematic end view of an example core of a stator for an electric machine.

[0041] FIG. 4D is a partial schematic end view of an example core of a stator for an electric machine.

[0042] FIG. 4E is a partial schematic end view of an example core of a stator for an electric machine.

[0043] FIG. 4F is a schematic end view of example end turns of a stator for an electric machine.

[0044] FIG. 4G is a schematic end view of example end turns of a stator for an electric machine.

[0045] FIG. 4H is a schematic side view of example end turns of a stator for an electric machine.

[0046] FIG. 4I is a schematic side view of example end turns of a stator for an electric machine.

[0047] FIG. 4J is a schematic cross-sectional view of an example stator for an electric machine.

[0048] FIG. 4K is a schematic cross-sectional view of example end turns of a stator for an electric machine.

[0049] FIG. 4L is a schematic of two example end turns.

[0050] FIG. 4M is a schematic of example end turns.

[0051] FIG. 4N is a schematic of example end turns.

[0052] FIG. 4O is a schematic of example end turns.

[0053] FIG. 4P is a schematic side view of example end turns of a stator for an electric machine.

[0054] FIG. 4Q is a schematic perspective view of example end turns of a stator for an electric machine.

[0055] FIG. 4R is a partial schematic cross-sectional view of an example core of a stator for an electric machine.

[0056] FIG. 4S is a partial schematic cross-sectional view of an example core of a stator for an electric machine.

[0057] FIG. 4T is a partial schematic cross-sectional view of an example core of a stator for an electric machine.

[0058] FIG. 4U is a partial schematic cross-sectional view of an example core of a stator for an electric machine.

[0059] FIG. 4V is a perspective view of an example wedge for insertion into one or more stator core slots.

[0060] FIG. 4W is a wiring diagram showing connections for one phase of a three phase electric machine.

[0061] FIG. 4X is a wiring diagram showing connections for one phase of a three phase electric machine.

[0062] FIG. 4Y is a wiring diagram showing connections for one phase of a three phase electric machine.

[0063] FIG. 4Z is a partial schematic end view of an example core of a stator for an electric machine.

[0064] FIG. 4AA is a partial schematic end view of an example core of a stator for an electric machine.

[0065] FIG. 4BB is a partial schematic end view of an example core of a stator for an electric machine.

[0066] FIG. 4CC is a partial schematic end view of an example core of a stator for an electric machine.

[0067] FIG. 4DD is a partial schematic end view of an example core of a stator for an electric machine.

[0068] FIG. 4EE is a schematic end view of example end turns of a stator for an electric machine.

[0069] FIG. 4FF is a schematic end view of example end turns of a stator for an electric machine.

[0070] FIG. 4GG is a schematic end view of example end turns of a stator for an electric machine.

[0071] FIG. 4HH is a schematic side view of example end turns of a stator for an electric machine.

[0072] FIG. 4II is a schematic cross-sectional view of an example stator for an electric machine.

[0073] FIG. 4JJ is a schematic cross-sectional view of an example stator core for an electric machine.

[0074] FIG. 4KK is a schematic cross-sectional view of an example stator core for an electric machine.

[0075] FIG. 4LL is a perspective view of an example wedge for insertion into one or more stator core slots.

[0076] FIG. 4MM is a perspective view of an example wedge for insertion into one or more stator core slots.

[0077] FIG. 4NN is a schematic end view of an example stator core for an electric machine.

[0078] FIG. 4OO is a perspective view of an example wedge for insertion into one or more stator core slots.

[0079] FIG. 4PP is a schematic end view of an example stator core for an electric machine.

[0080] FIG. 4QQ is an example slot liner for a stator slot of an electric machine.

[0081] FIG. 4RR is an end view of an example stator core for an electric machine showing the slot liner of FIG. 4QQ residing in the slot and retained by a liner clamp.

[0082] FIG. 4SS is an end view of an example stator core for an electric machine showing the slot liner of FIG. 4QQ residing in the slot and retained by an alternate liner clamp.

[0083] FIG. 4TT is a partial perspective view of an example stator for an electric machine.

[0084] FIG. 4UU is an end view of an example stator for an electric machine.

[0085] FIG. 4VV is a partial perspective view of an example stator for an electric machine.

[0086] FIG. 4WW is a partial side view of an example stator for an electric machine.

[0087] FIG. 4XX is a partial perspective view of an example stator for an electric machine.

DETAILED DESCRIPTION

[0088] Referring to FIG. 1A, an electric machine system 100 includes an electric machine 102 coupled to a companion device 104. The electric machine 102 can operate as a generator, producing electrical power from mechanical movement, operate as a motor producing mechanical movement from electricity, or alternate between generating electrical

power and motoring. In generating electrical power, a prime mover supplies mechanical movement to the electric machine 102, and the electric machine 102 converts the mechanical movement into electrical power. In certain instances, the companion device 104 may be the prime mover. In motoring, the mechanical movement output from the electric machine 102 can drive another device. In certain instances, the electric machine 102 can drive the companion device 104. In certain instances, the electric machine 102 can operate to motor and drive the prime mover during specified conditions, and switch to generating electrical power and be driven by the prime mover during specified conditions. The electric machine 102 can be configured for primarily generating electrical power, primarily motoring, or to be reasonably efficient at both generating electrical power and motoring.

[0089] In general terms, the electric machine 102 includes a stationary member and a movable member that, by interaction of magnetic fields, generates electrical power as the movable member moves relative to the stationary member and/or moves the movable member as electrical power is applied to the stationary member. For convenience of reference herein, the electric machine 102 is described as a rotating electric machine, where the movable member is a rotor 106 supported to rotate in the stationary member, a stator 108. Rotor 106 is coupled to the companion device 104 to drive the companion device 104 and/or be driven by the companion device 104. While FIG. 1A illustrates a horizontally-oriented electric machine coupled to a horizontally-oriented companion device 104, other implementations may provide for a vertically-oriented electric machine coupled to and capable of driving vertically-oriented companion devices, among other orientations. Additionally, in other instances, the electric machine 102 can be another type of electric machine. For example, the electric machine 102 can be a linear electric machine, where the movable member is a linearly reciprocating shaft. The linearly reciprocating shaft may be coupled to the companion device 104 to drive and/or be driven by the companion device 104. As described in more detail below, the electric machine 102 is an alternating current (AC), synchronous, permanent magnet (PM) electric machine having a rotor 106 that includes permanent magnets and stator 108 that includes a plurality of formed or cable windings about a core. In other instances, the electric machine can be another type of electric machine, such as an AC, asynchronous, induction machine where both the rotor and the stator include windings or another type of electric machine. In certain instances, the electric machine 102 is carried by and contained within a housing 110. The housing 110 can be wholly separate from the companion device 104, separate from and coupled to the companion device 104, or partially or wholly shared with the companion device 104 (i.e., the electric machine 102 and companion device 104 carried by and contained within a common housing).

[0090] In certain instances, the electric machine system 100 may be a subsea electric machine configured for subsea operation, submerged in the open sea (i.e., outside of a well or a pipeline). To this end, the housing 110 is a pressure vessel sealed against passage of fluid between the interior of the housing 110 and the surrounding environment (e.g., the surrounding seawater). The housing 110 is constructed to withstand the ambient pressures about the electric machine system 100 and thermal loads exerted by the surrounding environment, as well as pressures and thermal loads incurred in operating the electric machine 102 and companion device

104. The housing **110** may be constructed of a material that resists corrosion, for example, stainless steel, nickel alloys such as Inconel a registered trademark of Special Metals Corporation, and/or other materials. The housing **110** may additionally or alternatively be plated or coated with a material that resists corrosion, for example, Inconel, epoxy, polyetheretherketone, ethylene chlorotrifluoroethylene and/or other materials. In certain instances, the housing **110** may carry anodes (not shown) to assist in resisting corrosion. In certain instances, the housing **110** may be coupled to a skid or other structure that aligns with and engages (e.g., by way of guide tubes that receive guide cones) other subsea structures.

[0091] In instances where the companion device **104** is a prime mover, the companion device can include a number of different possible devices. For example, the prime mover may include one or more of a fluid motor operable to convert fluid (gas/liquid) flow into mechanical energy, a gas turbine system operable to combust an air/fuel mixture and convert the energy from combustion into mechanical energy, an internal combustion engine, and/or other type of prime mover. In instances where the companion device **104** is driven by the electric machine **102**, the companion device can include a number of different possible devices. For example, the companion device **104** can include one or more of a rotating and/or reciprocating pump, rotating and/or reciprocating compressor, mixing device, or other device. Some examples of pumps include centrifugal pump, axial pump, rotary vane pump, gear pump, screw pump, lobe pump, progressive cavity pump, reciprocating positive displacement or plunger pump, diaphragm pump, and/or other types of pumps. Some examples of compressors include centrifugal compressor, axial compressor, rotary vane compressor, screw compressor, reciprocating positive displacement compressor and/or other types of compressors. The electric machine **102** can be coupled to two or more companion devices **104** at the same time.

[0092] Although shown with a single companion device **104**, the electric machine **102** can also be coupled to two or more companion devices **104** (to drive and/or be driven by the devices **104**). In certain instances, one or more companion devices **104** can be provided at each end of the electric machine **102**. For example, in a configuration with two companion devices **104**, one may be provided at one end of the electric machine **102** and another provided at an opposing end of the electric machine. In another example, a configuration with two companion devices **104** can have one provided at one end of the electric machine **102**, and another coupled to the first companion device. Also, if multiple companion devices **104** are provided, they need not all be of the same type of companion device.

[0093] FIG. 1B depicts an example electric machine system **100a** where the companion device **104a** is a pump driven by the electric machine **102a**. One pump companion device **104a** is shown. In other instances, more pump companion devices **104a** can be provided. For example, two pump companion devices **104a** could be provided on opposing ends of the electric machine **102a** (e.g., in a configuration similar to the compressor companion devices **104b** shown below). In certain instances, two or more pump companion devices **104a** could be provided on the same side of the electric machine **102a**. The example electric machine system **100a** is configured for subsea operation, submerged in the open sea (i.e., outside of a well). In other words, the example electric machine system **100a** is a subsea pump system.

[0094] The housing **110a** is a pressure vessel sealed against passage of fluid between the interior of the housing **110a** and the surrounding environment (e.g., the surrounding seawater). In certain instances, the housing is flooded with a heat transfer fluid that is communicated to both the rotor **106** and the stator **108**. In certain instances, the heat transfer fluid includes a liquid, is primarily a liquid and/or is entirely liquid. The heat transfer fluid can include water, mono-ethylene glycol (MEG), mono-propylene glycol (MPG), an oil, a fluid similar to or the same as that being pumped by the pump companion device **104a**, and/or other fluid. Although referred to herein as a heat transfer fluid, the fluid may perform functions other than to provide heat transfer with the electric machine **102a**. In certain instances, the fluid lubricates bearing surfaces and/or performs other functions. In certain instances, the heat transfer fluid is maintained at pressure above the maximum operating pressure attained by the pump companion device **104a**. Because the heat transfer fluid is at a pressure above the maximum operating pressure attained by the pump companion device **104a**, leakage between the electric machine **102a** and the pump companion device **104** tends to be leakage of the heat transfer fluid towards the pump companion device **104a**. In certain instances, the pressure of the heat transfer fluid is above the ambient pressure about the exterior of the electric machine system **100a** by an amount substantially greater than the incidental pressure incurred in circulating the heat transfer fluids through the electric machine system **100a**. The housing **110a** has a flange **112** proximate the drive end of the electric machine **102a**. Flange **112** is configured to be sealingly joined, by bolts and/or otherwise, to the companion device **104a**, for example, at a corresponding flange **124** of the companion device **104a**. In certain instances, a seal (e.g., ring gasket, o-ring and/or other) may be provided between flange **112** and flange **124**. FIG. 1B depicts a close-coupled subsea pump system, in that the housing **110a** of the electric machine **102a** attaches directly to the housing **148** of the pump companion device **104a**. In other instances, the subsea pump system can be of an integrated configuration where the electric machine and companion device have a common housing and/or common shaft. For example, in some common housing configurations, the housing body that surrounds both the electric machine and the companion device can be a unitary piece (i.e., not readily separable, such as by removal of fasteners). In some common shaft configurations, the rotor of the electric machine can be unitary with the drive shaft of the companion device (i.e., not readily separable, such as by removal of fasteners or by release of the drive coupling). In other instances, subsea pump system can be of a non-integrated configuration having the housing of electric machine **102a** wholly separate (not coupled and/or substantially coupled) from the housing of the pump companion device **104a**.

[0095] The housing **110a** as shown is configured in four main elements including a housing body **114**, a drive end plate **116a** proximate the drive end of the electric machine **102a**, a non-drive end plate **118a** opposite the drive end of the electric machine **102a**, and an end cap **119** at the end of the housing body **114** adjacent the non-drive end plate **118a**. In certain instances, the housing **110a** may be configured in fewer or more elements. One or more seals **120** (e.g. gaskets, o-rings and/or other) may be provided between the end cap **119** and the housing body **114** to seal against passage of fluid into and/or out of the housing **110a**. In certain instances, seals may additionally or alternatively be provided between the

drive end plate **116a** and the housing body **114** and/or between the non-drive end plate **118a** and the housing body **114**. A drive stub **117a** of the rotor **106** extends through the drive end plate **116a** to communicate mechanical movement with the companion device **104a**.

[0096] The end plates **116a**, **118a** carry bearings **122** that receive and support the rotor **106** to rotate about a rotational axis in the stator **108**. The bearings **122** can be a number of different possible types of bearings, and the number and types of bearings carried by the drive end plate **116a** can be different from the number and types of bearing carried by the non-drive end plate **118a**. The bearings **122** can include one or more of journal bearings (e.g., a tilt-pad journal bearing and/or other type), magnetic bearings (e.g., such as that described in U.S. Pat. No. 6,700,258, U.S. Pat. No. 6,727,617, U.S. Patent Publication No. 2002/0175578 and/or other type), hybrid magnetic bearings, ball bearings and/or other types of bearing. One or more of the bearings **122** is a thrust bearing (e.g., a tilt-pad thrust pad and/or other type). In certain instances, non-drive end plate **118a** includes at least one axial or thrust bearing to axially retain the rotor **106** relative to the housing **110a** and at least one radial bearing to provide radial support to the rotor **106** relative to the housing **110a**, and the drive end plate **116a** includes at least one radial bearing to provide radial support to the rotor **106** relative to housing **110a**.

[0097] The stator **108** is generally cylindrical and the outer diameter thereof is closely received in the inner diameter of the housing **110a** to support the stator **108** relative to the housing **110a**. The outer diameter of the stator **108** may be keyed (using a protruding male key received in a female receptacle), bolted and/or otherwise secured to the inner diameter of the housing **110a** to rotationally affix the stator **108** relative to the housing **110a**. In certain instances, the stator **108** is axially retained with end rings **126** that are bolted and/or otherwise affixed to the housing **110a**. One or more penetrators **128** (one shown for simplicity of illustration) are provided through and sealed or substantially sealed with the housing **110a** to communicate fluid and/or electrical power into the interior thereof. In certain instances, for example in connection with a three phase electric machine **102a**, at least three penetrators **128** are provided to conduct electrical conductors from a power electronics system (i.e., control system for the electric machine) to the windings of the stator **108**. Another penetrator **128** may be provided that includes a conduit coupled to a supply heat transfer fluid to replenish any heat transfer fluid leaked from the housing **110a**.

[0098] The non-drive end of the rotor **106** carries a fluid circulation pump **130** that circulates the heat transfer fluid in the housing **110a** and through an external heat exchanger **132**. The pump **130** is coupled to the non-drive end of the rotor **106** to rotate with the rotor **106**. The pump **130** can be a number of different types of pumps, including a shrouded or unshrouded centrifugal impeller pump, radial impeller pump, rotary vane pump, gear pump, screw pump, lobe pump and/or other type of pump. In certain instances, the external heat exchanger **132** includes a continuous conduit helically coiled around the exterior of the housing **110a**. The external heat exchanger has an outlet proximate the drive end of the electric machine **102a** and an inlet proximate the pump **130**. The pump **130** pumps heat transfer fluid through ports **134** in the non-drive end plate **118a** into the external heat exchanger **132**. The fluid flows toward the drive end of the electric machine **102a** over the stator **108** and through the gap between the stator **108** and the

rotor **106** and through gaps between the stator **108** and the housing **110a**. In instances where the heat transfer fluid is cooler than the stator **108** and/or rotor **106**, the fluid extracts heat from (i.e., cools) the stator **108** and/or rotor **106**. In some instances, when the shaft-driven circulation pump is mounted on the drive end, the fluid at the drive end of the electric machine **102a** flows into the heat exchanger **132**, is cooled as it is circulated through the helical coil and is returned to the non-drive end of the electric machine **102a** over the stator **108** and through the gap between the stator **108** and the rotor **106** and through axial gaps between the stator **108** and the housing **110a**, and back to the pump **130** to repeat circulation. In other instances, the fluid circulation gaps between the stator **108** and the housing **110a** can be omitted. In instances where the electric machine system **100a** is subsea, seawater helps cool the heat transfer fluid circulated through the helical coil of the heat exchanger **132**. Although shown as cooling the heat transfer fluid from within the housing **110a**, the external heat exchanger **132** could additionally or alternatively receive and cool process fluids being acted upon by the companion device. Additionally, as described below the heat transfer fluid in the housing **110a** and the process fluids can be one in the same. In certain instances, the heat exchanger **132** could be used for cooling fluids from within the housing **110a** and an additional external heat exchanger (not shown) can be provided about the housing **110a** to receive and cool process fluids being acted upon by the companion device.

[0099] Although the pump companion device **104a** can be a number of different types of pumps, FIG. 1B depicts a multistage centrifugal pump. Eight centrifugal impellers **140a** are depicted arranged on central drive shaft **142a** of the pump companion device **104a**. In other instances fewer or more impellers can be provided. The drive shaft **142a** is shown coupled to the drive stub **117a** of rotor **106** by a drive coupling **144**. Although drive coupling **144** is shown as having two female ends that internally receive male ends of the drive stub **117a** and drive shaft **142a**, in other instances the drive coupling **144** can be a male coupling received into female receptacles provided in the drive stub **117a** and the drive shaft **142a**. In certain instances, the manner of coupling the drive stub **117a** and the drive shaft **142a** can include a combination of both male and female drive coupling configurations and/or other configurations. In certain instances, the drive shaft **142a** could be integral with the rotor **106** (i.e., constructed as unitary part with the rotor **106**, having no coupling, gear box, screw thread or other mechanical connection). The drive shaft **142a** is supported on bearings **122** carried in a pump body **146a** secured to the companion machine housing **148**. As above, the bearings **122** can be a number of different possible types of bearings, and the number and types of bearings can be different at different locations along the drive shaft **142a**. The bearings **122** can include one or more of journal bearings (e.g., a tilt-pad journal bearing and/or other type), magnetic bearings, hybrid magnetic bearings, ball bearings and/or other types of bearing. One or more of the bearings **122** is a thrust bearing (e.g., a tilt-pad thrust pad and/or other type). In certain instances, drive end of the drive shaft **142a** (nearest drive coupling **144**) includes at least one axial or thrust bearing to axially retain the drive shaft **142a** relative to the pump body **146a** and at least one radial bearing to provide radial support to the drive shaft **142a** relative to the companion machine housing **148**, and the non-drive end of the drive shaft **142a** includes at least one radial bearing to provide radial support to the drive shaft **142a**

relative to the companion machine housing 148. A seal 120 may be provided about the drive shaft 142a to seal or substantially seal against flow of fluids from the centrifugal impellers 140a towards the electric machine 102a.

[0100] The companion machine housing 148 includes an inlet 150 through which the process fluid being pumped is communicated to the centrifugal impellers 140a. Rotating the centrifugal impellers 140a pumps the fluid towards an outlet 152 of the companion machine housing 148. In other implementations, the fluid flow may be reversed such that the centrifugal impellers 140a are adapted to produce a fluid flow from the outlet 152 through the machine housing 148 and out through the inlet 150.

[0101] In operation of the electric machine system 100a, three phase AC electric current is provided to the stator 108 of the electric machine 102a via the penetrators 128. The electrical current energizes windings of the stator 108, and causes the rotor 106 to rotate. Rotating the rotor 106 drives the drive shaft 142a of the pump companion device 104a and pumps process fluid from the inlet 150 to the outlet 152. Rotating the rotor 106 also drives the fluid circulation pump 130 to pump fluid from non-drive end of the electric machine 102a into the heat exchanger 132, towards the drive end, over the stator 108 and through the gap between the stator 108 and the rotor 106, towards the non-drive end of the electric machine 102a. Fluid proximate the non-drive end of the electric machine 102a flows into the heat exchanger 132 and is cooled as it passes through the helical coil of the heat exchanger 132 to drive end of the electric machine 102a. Depending on the configuration of the shaft-driven fluid circulation pump, fluid can alternatively flow in the reverse direction (i.e., through the heat exchanger 132 toward the non-drive end).

[0102] FIG. 1C depicts an example electric machine system 100b where the companion device is a compressor 104b. In FIG. 1C, the example electric machine system 100b includes two compressor companion devices 104b arranged on opposing ends of the electric machine 102b. In other instances, fewer or more compressor companion devices 104b can be provided. In certain instances, two or more pump companion devices 104a could be provided on the same side of the electric machine 102a. The example electric machine system 100b is configured for subsea operation, submerged in the open sea (i.e., outside of a well). In other words, the example electric machine system 100b is a subsea compressor system.

[0103] In general, the configuration of the electric machine system 100b is similar to that of the electric machine system 100a discussed above. FIG. 1C shows the system 100b configured for a cartridge type installation/removal of the electric machine 102. To this end, all or a majority of the electric machine 102, including the stator 108 and the rotor 106, is carried in an intermediate housing 115 that is received by the housing 110b. The intermediate housing 115 carrying electric machine 102 components can be installed into or removed from the main housing 110b as a unit or cartridge. The cartridge type installation/removal simplifies service or replacement of the electric machine 102, because the electric machine 102 need not be assembled/disassembled piece by piece into the main housing 110b. Moreover, the electric machine 102 can be assembled into the intermediate housing 115 and tested prior to installation into the main housing 110b.

[0104] Also notable, the interior of the housing 110b is in communication with the process fluids on which the compressor companion devices 104b are operating. Thus, the

components of the electric machine are exposed to the process fluids during operation of the electric machine system 100b. The process fluids are under pressure, because they have been compressed by the compressor companion devices 104b. In certain instances, the process fluids are above the ambient pressure about the exterior of the electric machine system 100b by an amount substantially greater than the incidental pressure incurred in circulating the process fluids through the electric machine system 100b. In certain instances, communication is established by omitting a seal or providing an imperfect seal about the drive shaft 142b of the compressor companion device 104b and/or providing other fluid communication paths from the compressor companion device 104b. The end plates 116b, 118b may be additionally provided with ports 154 to facilitate communication of process fluids into the gap between the rotor 106 and stator 108. The electric machine 102b may also be provided without an integrated fluid circulation pump 130.

[0105] In certain instances, the fluids used in operation of the electric machine, including heat exchange fluids and other process fluids, can contain constituents that may be corrosive, reactive and/or otherwise harmful to one or more of the components of the electric machine 102b. As described in more detail below, the rotor 106 and stator 108 may be fortified against exposure to the process fluids. In certain instances, as described in more detail below, the rotor 106 and/or stator 108 may be sealed against exposure to the process fluids and/or coated with protective coatings.

[0106] Although the compressor companion device 104b can be a number of different types of compressors, FIG. 1C depicts multistage centrifugal compressors. Eight centrifugal impellers 140b are depicted arranged on central drive shaft 142b of the compressor companion device 104b. In other instances fewer or more impellers can be provided. As above, the drive shaft 142b is shown coupled to the drive end of rotor 106 by a drive coupling 144. In other instances, the drive shaft 142b could be integral with the rotor 106 (i.e., constructed as unitary part with the rotor 106, having no coupling, gear box, screw thread or other mechanical connection).

[0107] FIG. 1C depicts an electric machine system 100b incorporating magnetic bearings 122. In certain instances, one end of the rotor 106 may be supported by an axial and radial magnetic bearing 122 carried in the end plate 118b and the other end of the rotor 106 supported by a radial magnetic bearing 122 carried in end plate 116b. Additional conventional bearings, for example cartridge ball bearings and/or another type, may be provided to provide secondary and/or contingency support the rotor 106. The companion devices 104b can also be provided with magnetic bearings 122 carried in the compressor body 146b.

[0108] In operation of the electric machine system 100b, three phase AC electric current is provided to the stator 108 of the electric machine 102b via the penetrators. The electric current energizes windings of the stator 108, and causes the rotor 106 to rotate. Rotating the rotor 106 drives the drive shaft 142b of the compressor companion devices 104b and compresses process fluid from the inlet 150 to the outlet 152. A portion of the process fluids is communicated with the interior of housing 110b, causing process fluid to circulate over the stator 108 and through the gap between the stator 108 and the rotor 106. An additional flow of fluid may be provided through the heat exchanger 132 to be cooled as it passes through the helical coil of the heat exchanger 132.

[0109] FIG. 2A depicts a cross-sectional view of an example rotor 200 for use in an electric machine system, such as a motor and/or a generator. Rotor 200 could be used as rotor 106 described above. Additionally, implementations of the rotor 200 can be adapted for subsea operation and/or operation in corrosive environments. In certain instances, portions of the rotor 200 and rotor components can be coated or treated for corrosive resistance with Inconel, epoxy, polyetheretherketones (PEEK), ethylene chlorotrifluoroethylene copolymer and/or other treatments. The rotor 200 can include rotor core having a rotor hub 202 and rotor shaft 206. The rotor hub 202 is adapted to support permanent magnets 204 positioned so as to magnetically interact with a stator provided in the electric machine system. The magnets 204 can be bonded or otherwise connected to the rotor hub 202. High energy permanent magnets 204 can be used, for example neodymium-iron-boron based, or samarium-cobalt based magnets. In certain instances, the permanent magnets 204 are bonded to the rotor hub 202. A rotor shaft 206 can be provided, forming a rotational axis of the rotor 200. The rotor shaft 206 extends axially from both ends of the rotor hub 202. The rotor shaft 206 may be constructed as a single piece or modularly from a plurality of shaft segments. In certain instances, the rotor shaft 206 can be hollow, including the rotor hub, to promote rotor cooling or to facilitate flow of fluid through the electric machine. The rotor 200 can further include one or more cooling passages 217 through the interior thereof to communicate fluid through the interior of the rotor. In FIG. 2A, a central passage 217 through center of rotor, entering on circumferential surface of the rotor hub 202, is shown.

[0110] A rotor sleeve 212 can serve to enclose the outer surface of the entire rotor 200 or portions of the rotor 200, such as the rotor hub 202 and magnets 204. The rotor sleeve 212 can be manufactured from material that allows the sleeve to protect rotor components as well as provide structural support to rotor components, such as the rotor hub 202. In certain instances, the rotor sleeve 212 can be constructed from a fiber reinforced composite, such as a carbon fiber composite, aramid fiber composite (e.g., Kevlar a registered trademark of I.E. Dupont De Nemours), or fiber glass composite, a metal (e.g., Inconel, stainless steel, MP35N a registered trademark of SPS Technologies, Inc. and/or other metal), and/or other material. For instance, a sleeve covering 212 can serve to provide radial support for the rotor hub 202 and magnets 204 positioned thereon, preventing loosening or detachment of magnets 204 from the rotor hub 202 during operation of the rotor 200 at high rotational speeds.

[0111] In certain instances, the sleeve 212 can also serve to insulate the rotor 200 and rotor components from outside elements. For example, in rotors adapted for subsea and/or exposure to corrosive environments operation, the sleeve 212 can be adapted to be air- or water-tight, in order to seal the rotor components. For example, the electric machine system in which the rotor 200 is disposed may contain heat transfer fluid, process fluids, and/or other fluids harmful to the rotor 200. The sleeve 212 may cover and isolate those portions of the rotor 200 sensitive to corrosion or otherwise adverse to contact with the fluid.

[0112] In certain instances, the rotor 200 may incorporate rotor elements and techniques for mounting the rotor sleeve 212 to the rotor 200 so as to seal at least the rotor hub 202. As shown in the example of FIG. 2B, rotor 200 can include end rings 214 positioned at one or both ends of the rotor hub 202 and mounted coaxially on the rotor shaft 206. In this example,

the end ring 214 is bonded or otherwise attached to the rotor 200 so that the inner surface of the end ring 214 abuts the end of the rotor hub 202, extending radially so as to provide axial support to magnets 204 positioned on the rotor hub 202. The end rings 214 are positioned at each end of the rotor hub 202. The end ring 214 can be of metallic material (e.g., Inconel, MP35N and/or other material). In certain instances, the material can be selected for its ferromagnetic properties as well, so as to enhance or avoid interference with the electromagnetic function of the magnetic rotor hub 202. Additionally, certain instances of the end ring 214 may be constructed so as to make the end ring corrosion-resistant, for example, through galvanization or anodization of the end ring material. In other instances, the end rings 214 can be built into or integrated into the rotor hub 202 itself. For example, a rotor hub 202 may be provided with an inset for mounting the magnets, resulting in the end sections of the hub having a larger diameter than the inset.

[0113] A ledge 217 can be provided circumferentially on the outside diameter of the end ring 214. The ledge 217 serves as a landing platform for the positioning of an end treatment strip 220 around the outside diameter of the end ring 214, the end treatment strip 220 forming a cylinder or a hoop. In certain instances, the outer diameter of the thin end treatment strip 220 is equal or approximately equal to the diameter of the rotor hub 202, including the magnets 204 mounted thereon. The end treatment strip 220 can be a composite material capable of bonding to the sleeve 212. In certain instances, the end treatment strip 220 and sleeve 212 are constructed from similar materials, such as pre-impregnated carbon fiber or other material. A circumferential groove 221 can also be provided on the ledge 217 of the end ring 214, in order to provide for a seal 222 (e.g., an o-ring, gasket and/or other seal) to be positioned on the ledge surface 217. The seal 222 seals or substantially seals between the end ring 214 and the end treatment strip 220 wrapped around the end ring's ledge 217. Of note, in certain instances, the circumferential groove 221 can be machined onto the end rings 214 before and/or after the end rings 214 are installed to the rotor 200 (as discussed below).

[0114] In one example, the sleeve 212 can be sealed to the rotor 200 by sliding and/or threading the end rings 214 onto the shaft 206 so as to abut the ends of the rotor hub 202. In certain instances, a seal (e.g., o-ring, gasket and/or other seal) and/or sealant (e.g. thread sealant, sealant applied to the juncture between the shaft 206 and end rings 214, and/or other sealant) can be provided between the shaft 206 and the end rings 214. The seal 222 can be positioned in the end ring 214 before or after positioning and connecting the end ring 214 to the shaft 206. In an instance where the end rings 214 are threaded onto the shaft 206, the respective threads of the end rings 214 can be oriented so that the end rings 214 are tightened to the shaft 206 when the rotor 200 is rotated in normal operation. In some instances, the end rings 214 can additionally be affixed to the rotor hub 202 with an adhesive.

[0115] After rigidly connecting the end ring 214 to the shaft 206 (e.g., by threading, welding and/or otherwise), the end treatment strip 220 is positioned on the outside diameter of the end ring 214 on the ledge 217. The end treatment strip 220 may then be wound onto the ledge 217, to position the strip 220 on the end ring 214, or may simply be slipped over the end ring 214 into position on the ledge 217. With the end rings 214, seals 222, and end treatment strips 220 in place, the construction of the sleeve 212 can be completed. Winding or

otherwise securely wrapping the sleeve 212 onto the rotor hub 202 and on top of the end treatment strip 220 can press the end treatment strip 220 radially down onto the ledge surface 217, causing the strip 220 to shrink tightly onto the end ring 214. This pressure, in turn, compresses the seal 222 into the groove 221 to form a seal between the strip 220 and the end ring 214. As the sleeve 212 is wound onto the rotor 200 the sleeve 212 is bonded to the strip 220. This bonding extends the seal between the strip 220 and end ring 214 to the sleeve 212, thereby sealing the rotor hub 202 covered by sleeve 212. In certain instances, clamps may be employed to secure the strip 220 to the end ring 214 while the sleeve is wrapped to the rotor 200 and bonded to the strip 220. Additionally, the bonding of the strip 220 to the sleeve 212 can occur at an elevated temperature, to allow for a bond that will be less temperature sensitive.

[0116] Alternative techniques can be employed to seal the sleeve to the rotor assembly. For example, in some implementations, the end treatment strips 220, the seal 222, and seal groove 221 may be omitted. In some instances, the sleeve may be securely wound onto the rotor hub 202 and the circumferential surfaces of the end rings 214. The sleeve 212 may be fabricated from carbon fiber impregnated with thermoplastic material such as polyetheretherketone (PEEK). Thermoplastic material, such as PEEK, may also be applied to or pre-coated on the outer diameter of the end rings 214 prior to having the sleeve 212 wound on the hub assembly. Where grinding of the rotor assembly may be required, pre-coated end rings 214 may be provided with sufficient material so that a coating formed from PEEK (or other material), for example, remains on the end rings 214 following grinding and before the sleeve 212 is wound over both the end rings 214 and rotor hub assembly. With the sleeve in contact with the PEEK-coated end rings, heat or pressure may be applied to bond the sleeve to the end ring, forming a seal with the PEEK at each end of the sleeve 212, thereby isolating the rotor hub, magnet segments, and other components covered by the sleeve from contact with potentially hazardous external fluids and/or other materials.

[0117] After the sleeve 212 is wrapped on the rotor 200 secondary end rings 215 may be slid and/or threaded onto the shaft 206 so as to abut the end rings 214. The secondary end rings 215 have a diameter substantially equal to the sleeve 212 diameter, and serve to protect the outer surface of the sleeve 212 and/or to provide a location for rotor balancing (either by material removal or addition). In certain instances, a seal (e.g., o-ring, gasket and/or other seal) and/or sealant (e.g. thread sealant, sealant applied to the juncture between the shaft 206 and secondary end rings 215, and/or other sealant) can be provided between the shaft 206 and the secondary end rings 215. Additionally, the juncture between the secondary end rings 215 and the end rings 214 can be filed with resin and/or adhesive (thus, adhering the secondary end rings 215 to the end rings 214 and filling). In an instance where the secondary end rings 215 are threaded onto the shaft 206, the respective threads of the secondary end rings 215 can be oriented so that the secondary end rings 215 are tightened to the shaft 206 when the rotor 200 is rotated in normal operation. In certain instances, the outward facing edges of the secondary end rings 215 can be rounded or the rings' outer surface may be conical (with the smaller diameter facing outward) to facilitate fluid flow over the secondary end rings 215.

[0118] Some implementations may employ additional measures to protect the ends of the sleeve 212 in addition to or in lieu of the secondary end rings 215. For example, tubular bands, constructed of material more resistant to wear and other damage than the composite sleeve 212 (e.g., non-magnetic metal, ceramic, polymer and/or other material), may be positioned at each end of the rotor hub, concentrically atop the sleeve 212. Consequently, the tubular bands may cover the ends of the sleeve, thereby protecting the ends of the sleeve from erosion, abrasion, or other damage that may occur during operation of the rotor 200. In another implementation, illustrated in FIGS. 2C and 2D, a tubular band may be replaced with a thin, non-magnetic, metal alloy tape 223 (e.g., nickel alloy (e.g., Inconel), non-magnetic stainless steel, titanium and/or other metal) wrapped around the outer surface of the rotor sleeve 212 and bonded to end rings (not shown) positioned on the rotor shaft 206 to form a sleeve 229. In some instances the metal can be corrosion resistant. In some implementations, an insulating coating and/or surface treatment may be applied to the tape 223 to inhibit currents from circulating between adjacent laps of the tape 223. Some examples of coating and/or surface treatment include oxidation, anodization, phosphate/chromate/silicate coating (e.g., American Society for Testing and Materials (ASTM) A976 C-4 and/or C-5) and/or other coatings. In some implementations, the sleeve 229 may extend axially beyond the edges of the rotor sleeve 212.

[0119] In one implementation, a first end of a piece of tape 223 may be bonded to an end ring adjacent to a first sleeve end 225. The tape 223 may be bonded to the end ring using a laser weld, resistance weld, TIG weld, chemical bond, or any bonding method. The tape 223 may be wound on top of the rotor sleeve with adequate tension so as to cover the sleeve ends and maintain positive pressure between the tape 223 and the rotor sleeve 212 in all operating conditions of the rotor 200. The resulting tape winding 223 may be laid in butt laps across the outer surface of the rotor sleeve, resulting in a smooth surface that minimizes the thickness of the tape wrapping 223. Thin alloy tape wrappings 223 may, among other advantages, minimize parasitic mass as well as parasitic currents appearing in the metallic tape as a result of the magnetic field of the rotor 200 or corresponding electric machine. Other implementations may employ other winding techniques as well as various tape material for reinforcing and protecting the rotor sleeve. Upon winding the tape across the rotor hub 202 to cover the second end of the sleeve 227, the second end of the piece of tape 223 may be bonded to the opposite end ring. In some instances, for example in a butt lap winding, excess tape may result at the edges of end rings. The excess tape may be trimmed flush with the end ring faces to complete the tape winding 223.

[0120] FIG. 2E is a detailed cut-away cross-sectional view of an example sleeve 212. The sleeve 212 can be manufactured or constructed of any material possessing the structural, resistive, and/or chemical properties desired for the particular rotor implementation, for example a fiber-reinforced composite. The sleeve 212 can serve a number of functions. For example, in subsea and/or corrosive environment rotor implementations, the sleeve 212 can be constructed of composite material capable of providing structural support and corrosion protection for the rotor hub, as well as sealing the rotor hub from exposure to foreign elements. Heating of the rotor 200 can result in thermal expansion of one or more of the rotor elements or sleeve. Where heating is uneven across the rotor,

some sections of the rotor and rotor sleeve can expand differentially relative to other sections. Differential thermal expansion can result in differential, and potentially damaging, stresses on the sleeve 212. Stress can arise due to differential expansion of the sleeve itself or from differential expansion of the underlying rotor structure. Accordingly, the below described sleeve configurations can, among other benefits, more uniformly control and/or accommodate thermal expansion, both of the sleeve and the rotor itself.

[0121] In some instances of rotor sleeve 212, a fiber-reinforced composite sleeve material, such as carbon fiber, can be employed. In certain instances, as illustrated in the example of FIG. 2E, the sleeve may be multi-layered. FIG. 2E shows a multi-layer fiber-reinforced composite sleeve wrapping 212. The top layer 224 (or, in certain instances, layers) are cosmetic layers. These layers may possess functional characteristics as well. For example, to achieve strength and rigidity as well as control differential thermal expansion in one or multiple directions, the layers can have fibers oriented predominantly or all in the same direction (e.g. maximum strength in one direction) or different orientations (strength in multiple directions).

[0122] In certain instances, intermediate layer 226 can be a first, primarily axially-oriented carbon fiber composite layer layered beneath the cosmetic layer 224 (i.e., nearer to the outer circumferential surface of rotor 200). The layer 226 can be made of pre-impregnated carbon fiber composite sheet capable of providing very strong axial support as well as provide corrosion and leakage protection. Layer 228, positioned beneath layer 226, can be one or more carbon fiber composite layers with primarily circumferentially-oriented pre-impregnated carbon fiber tape. Layers with circumferentially-oriented carbon fiber, such as layer 228, do not provide substantial axial strength, instead providing circumferential strength. Additionally, circumferentially-oriented carbon fiber layers, while useful in controlling radial thermal expansion, are less effective at useful for limiting axial expansion. Layer 230 is a bottom, primarily axially-oriented carbon fiber layer and in certain instances is made from pre-impregnated carbon fiber composite sheet. Axially-oriented layers, such as layer 230, can remedy the structural deficiencies of circumferentially-oriented carbon fiber layers, both in terms of structural and thermal expansion support. Accordingly, in some instances, intermediate 226 and bottom layers 230 can have substantially axial reinforced composite fibers, the layer 228 having substantially circumferential reinforced composite fibers.

[0123] Layer 230 can be wrapped so as to directly contact the rotor 200, rotor hub 202, rotor hub magnets 204, and/or end rings 214, covering all or a portion of the rotor 200. In certain instances, additional layers can be provided between layer 230 and the rotor 200. Additional layers may also be provided between layers 224, 226, 228, and 230. Indeed, certain instances may make use of repeated layering of layers 224, 226, 228, 230 in similar or different orientations and orders. Although discussed above with respect to axially-oriented and circumferentially-oriented layers, the orientations of one or more of the layers 224, 226, 228, 230 could be oriented in non-axial and/or non-circumferential directions. For example, one or more of the layers 224, 226, 228, 230 could be oriented at 45 degrees, 30 degrees and/or another angle relative to the axial direction. Indeed, in some instances, fibers in a fiber-reinforced composite, need not be oriented in the same direction. Accordingly, in some instances, fiber-

reinforced composites can be selected for the axial and circumferential support that have fibers primarily in one of the axial or circumferential direction. The layer, in such an instance, can have a greater density of fibers oriented on one orientation or dimension, than in another dimension.

[0124] The material forming the layers of a multi-layered sleeve 212 need not be uniform. In certain instances, the one or more layer materials may be selected so as to minimize stress on the rotor hub 202, magnets 204, as well as the surrounding sleeve 212 due to thermal expansion during operation. One technique for minimizing these stresses is to build the sleeve 212 so that the sleeve 212 expands axially with the interior rotor components at the rotor's 200 operating temperature.

[0125] The rotor 200, rotor components, and sleeve layers expand according to the coefficient of thermal expansion (CTE) of materials used in the rotor and sleeve. Accordingly, rotor sleeve 212 materials can be selected and/or engineered to have CTEs similar to the CTEs of the portion of the rotor 200 or rotor elements to be covered by the rotor sleeve 212. For example, in a fiber-reinforced composite rotor sleeve, the fiber and/or resin employed to form the rotor sleeve, can be selected so as to result in a composite sleeve material with a CTE equal or substantially equal to, complimenting, or otherwise matched to the CTE of the rotor shaft 206, rotor hub 202, and/or magnet 204 material. Matching CTE can, among other benefits, allow the sleeve 212 to expand with the expansion of the rotor components wrapped in the sleeve 212.

[0126] In some instances, in order to achieve a desired CTE in a sleeve layer or rotor component, material used in the sleeve or rotor component can be doped with other material having a higher or lower CTE so as to affect the net CTE of the resulting sleeve or rotor component. For instance, the resin of a carbon fiber sleeve layer could be doped so that the CTE of the carbon fiber sleeve layer matches the CTE of rotor components covered by the sleeve, for example neodymium-iron-boron based, or samarium-cobalt based magnets mounted on the rotor hub 202. Additionally, the density of fibers used in a fiber-reinforced sleeve can also be adjusted so as to engineer the net CTE of the sleeve or sleeve layer. In certain instances, one or more layers, including axially oriented, circumferentially oriented and/or other oriented layers, may be selected with varying CTEs so as to engineer a sleeve having a net CTE matched to the relevant portions of the rotor 200 to be covered by the sleeve 212. In certain instances, non-CTE-matched sleeve layers can be provided in addition to CTE-matched sleeve layers in the sleeve 212. For example, sleeve layers closest to the rotor hub 202 surface may be selected with CTE matched to the CTE of the rotor hub or rotor hub components, while outer sleeve layer material is selected based on other considerations, such as structural support, puncture resistance, or corrosion resistance.

[0127] In some implementations, the CTE of the rotor 200 to be covered by the sleeve 212, can vary across the rotor 200, depending, for example, on the rotor elements employed in and on the rotor 200. Rotors having differential CTE may result in differential thermal expansion in the rotor as well as the sleeve covering the rotor. Accordingly, in some implementations, rotor sleeves can be engineered to have differential CTE, for example by differential doping across the length of the sleeve, to correspond with varying CTEs in the rotor portions to be covered.

[0128] FIGS. 2F and 2G illustrate another implementation of an example rotor sleeve 212. FIG. 2F shows a detailed

cross-sectional view of a multi-layered rotor sleeve **212**. FIG. 2G is a detailed perspective view of the sleeve shown in FIG. 2F. A set of outer layers **232**, **234** can be provided in the sleeve **212** together with a set of segmented layers **236**, **238**, **239**, **240**. The outer layers **232**, **234** can include one or more composite layers, including axially, circumferentially and/or otherwise oriented layers. The segmented layers **236**, **238**, **239**, **240** are distinct, hoop-like layers. A segmented layer can expand and contract independent from other segmented layers. Where differential temperatures make differential expansion or contraction likely, segmented layers **236**, **238**, **239**, **240** can expand and contract in these regions of differential temperature and propagate less of the associated forces from expansion or contraction to other segmented layers, outer layers **232**, **234**, or the sleeve **212** generally.

[0129] In certain instances, the segmented layers **236**, **238**, **239**, **240** can assume widths and positions in the sleeve **212** coordinating with circumferential segmentation of magnets **204a**, **204b**, **204c**, **204d** on the rotor **200**. For example, as shown in FIG. 2F, in rotors having circumferentially segmented magnets **204**, the segmented layers **236**, **238**, **239**, **240** are positioned to align with the circumferential segmentation of one or more of the magnets **204a**, **204b**, **204c**, **204d** so that each segmented layer is aligned with one or more circumferential rows of magnets. This can allow for the expansion and contraction of each segmented layer **236**, **238**, **239**, **240** to be influenced by the thermal expansion and contraction of magnet row **204a**, **204b**, **204c**, **204d** positioned beneath it. While the example of FIGS. 2F and 2G show segmented layers with axial widths corresponding to a single magnet row, segmented layers can correspond with and cover more than one row of magnet segments. Additionally, segmented layers **236**, **238**, **239**, **240** can be fiber-reinforced composite hoops having primarily circumferentially-oriented fiber, so as to provide structural support to the magnet segments positioned beneath the hoop layer. In some instances, magnet segments may be subject to greater thermal expansion and structural vulnerabilities (e.g., during rotation of the rotor at high speed), requiring additional radial support to limit these liabilities.

[0130] In an illustrative example, the temperature at magnet **204a** may be higher than the temperature at magnet **204c**. The temperature differential between magnet rows **204a** and **204c** can result in magnet **204a** experiencing thermal expansion larger than that experienced at magnet row **204c**. Accordingly, segmented layer **236** positioned in alignment with magnet row **204a** may expand more than segmented layer **239** positioned in alignment with magnet row **204c**. Gaps may exist between the segmented layers **236**, **238**, **239**, **240** so that the expansion of one segmented row does not interfere with another segmented layer. Additionally, expansion forces in layers **232**, **234**, positioned above the segmented layer, resulting from differential thermal expansion corresponding with one or more hoop segments, may be focused at or near the corresponding hoop segment, including the gap between the affected hoop segments. For instance, in the above example, thermal expansion forces transmitted to layers **232**, **234** may be focused at the gap between adjacent hoop segments **236** and **238**; **238** and **239**; and **239** and **240**.

[0131] A segmented layer can also be accomplished using a unitary sleeve layer. For example, a sleeve layer can possess strength characteristics that vary across the length of the sleeve layer. Variation in sleeve layer strength can be aligned with elements, such as magnet segment rows, so that areas of highest strength are aligned with areas of the rotor requiring

greatest reinforcement or more subject to differential thermal expansion. For example, multiple layers of varying physical characteristics could be grouped to form a sleeve with band-like strength sections, with gaps between the sections exhibiting strength or thermal expansion characteristics different than the sections themselves. One way this may be accomplished is by fabricating sleeves with varied coefficients of thermal expansion (CTE). Additionally, in certain instances, the segmented layers **236**, **238**, **239**, **240**, or segmented hoops, aligned with magnet segment rows **204a**, **204b**, **204c**, **204d**, may be constructed of material with CTEs matched to the CTE of the magnet **204a**, **204b**, **204c**, **204d** positioned beneath it.

[0132] While FIGS. 2A, 2F, and 2G show examples of a rotor hub **202** with magnets **204** axially segmented (with segment boundaries formed in the circumferential plane along the axial body of the rotor hub **202**), the magnets **204** can also be implemented as single member magnets, extending axially across the length of the hub body **202**. Additionally, magnets can be segmented circumferentially (with segment boundaries formed in a radial-axial plane) as shown in 2E. Segmenting the magnets, however, can be advantageous as certain magnets may be more affordable and easier to implement as segmented pieces. Additionally, segmented magnets **204** can alter the electric and electromagnetic characteristics of the rotor and thereby be functionally desirable in some rotor applications.

[0133] FIGS. 2H-2P are cross-sectional views of example rotor hubs **202**. Magnets **204**, of uniform or non-uniform strength, can be mounted directly to the outer surface of the rotor hub **202** and/or to the rotor hub **202** via intermediate materials, for example, to electrically insulate the magnets **204** from the rotor hub **202**, bond or improve bonding to the rotor hub **202**, and/or other reasons. In certain instances, the intermediate material can include an adhesive (e.g., an acrylic adhesive and/or other adhesives), electrically insulating tape, a solder material, a reactive nanofilm, and/or another material. In certain instances an interstitial filler material is applied to the rotor **200** to fill spaces between the magnets **204** and/or the rotor hub **202**. An example material, includes stainless steel putty (e.g., stainless steel putty made by ITW Devcon) and/or other materials. In certain instances, the rotor **200**, prior to installation of the sleeve **212**, can be dipped in or flooded with an epoxy resin to ensure all the gaps between the magnets **204**, the rotor hub **202**, and/or the end rings **214** are filled and further protect against fluid ingress.

[0134] In certain instances interstitial filler material may be injected into the rotor hub assembly while providing a vacuum within the hub assembly. For example, once magnet segments **204** have been mounted to the rotor hub **202**, the magnets **204** and rotor hub **202** may be enclosed in a disposable sleeve (e.g., a polymer bag and/or other sleeve), and the sleeve may be sealed at both ends of the rotor hub assembly. The vacuum is operable to remove the air and/or other gases ("gases") within the sleeve, including gases residing in voids between the magnets **204** and/or the rotor hub **202**. A pre-catalyzed low-viscosity thermosetting resin may be introduced into the disposable sleeve to penetrate the empty spaces in the rotor hub assembly. Upon curing of the resin, the disposable sleeve may be removed. Thereafter, manufacture of the rotor may be resumed, including wrapping a protective rotor sleeve **212** around the rotor hub assembly.

[0135] In some implementations, the rotor sleeve **212** itself may be used in lieu of the disposable sleeve of the previous

example. Pluggable inlets may be provided on each of the end rings **214**, allowing a vacuum pump to be connected to one end of the hub assembly and a high pressure pump to be connected to the other end. The vacuum pump vacates air from the hub assembly, sealed by the sleeve **212**. With air removed from the inside of the hub assembly, the high pressure pump may inject the resin into voids in the hub assembly. The end ring inlets may be plugged and the resin cured to seal the hub assembly interior. Subsequent manufacturing operations may then be performed.

[0136] To facilitate filling the voids within the rotor hub assembly using the described or other techniques, the hub and/or the magnet segments may be provided with flow path channels to guide filler material into voids between the hub **202** and the magnet segments **204**. FIGS. 2Q-2R illustrate examples of such features. For instance, FIG. 2Q shows a rotor hub assembly **201** including a rotor hub **202** with a plurality of magnet segments **204** mounted on the hub **202**. The magnet segments **204** are each formed to take a geometry that results in flow path channels **258** being formed when the magnet segments **204** are mounted to the hub **202**. These channels **258** may be aligned with those areas of the hub **202** and magnet segments **204** where voids are likely to appear, such as areas between adjacent magnet segments **204**. In some instances, as shown in FIG. 2R, additional grooves **260** may be provided on the hub **202**, in lieu of or in addition to the geometry of the magnet segments **204**, to provide the flow paths **258**.

[0137] The end rings of the assembly may also be used to guide the flow of filler material. As shown in FIG. 2S, an interior face of an end ring **214**, to be set adjacent to the rotor hub, can be provided with an annular channel **262** operable to direct filler material around the rotor hub assembly and into voids or other flow path channels positioned around the rotor hub. In some implementations, an inlet **264** in communication with the channel **262** may be provided on the end ring **214**. The inlet **264** may be used to couple one or more vacuum pumps or injection pumps to the end ring **214** to deliver and direct filler material into voids within the hub assembly.

[0138] The magnets' dimensions and orientation on the rotor hub **202** may serve to form substantially a cylinder of magnet segments around the hub **202**. In some implementations, outer surfaces of the magnet segments may require grinding once the magnetic segments are mounted to the hub **202**. Grinding the outer surfaces of the magnetic segments may be used to form the rotor hub **202** into a substantially uniform cylindrical outer surface. Additionally, while the magnets, once coupled to the rotor, may form a uniform cylinder, individual magnet segments **204a-t** can vary in magnetic field orientation and magnitude as well as weight in order to achieve the desired electromagnetic, rotational and inertial rotor hub **202** profile.

[0139] FIG. 2H illustrates a cross-sectional view of one example rotor hub magnet configuration. In this example, sixteen circumferentially segmented magnets **204a-t** are positioned around the circumference of the rotor hub **202**. The geometry of the individual magnet segments **204a-t** and the outer surface of the rotor hub **202** allow for the magnet segments **204a-t** to be mounted directly to a rotor hub **202**. As shown in FIG. 2H, the outer surface of the rotor hub **202** in certain instances may not be perfectly round, for example, the portion of the rotor hub **202** where magnet segments **204a-t** are mounted may be a regular polygon with a number of equilateral sides equal to the number of magnet segments

204a-t to be mounted on the hub **202**. FIG. 2H shows the outer surface of the rotor hub **202** having sixteen flat surfaces, running the axial length of the rotor hub **202**, against which corresponding flat surfaces of the sixteen magnet segments **204a-t** abut. The flat surfaces on the rotor hub **202** and the magnet segments **204a-t** are normal to a radial line emanating from the center of the hub **202**.

[0140] The magnet segments **204a-t** can be arranged into a two pole configuration. For example, seven magnet segments **204a-g** with magnetic fields directed substantially radially away from the center of the rotor hub **202** may serve as a base of a north pole of the rotor's magnetic configuration. Seven other magnet segments **204j-s** can be positioned on the other side of the rotor hub **202**, each magnet segment **204j-s** having magnetic fields directed substantially radially toward the center of the rotor hub **202** serving as a base for a south pole of the rotor's magnetic configuration. A magnet segment **204** may be magnetized so that the magnetic field vector of the magnet segment is uniform. In other words, the magnetic field vector at any one point along a uniform magnetized magnet segment is parallel to the magnetic field vector at any other point along the magnet segment, as illustrated in FIG. 2T. In certain instances, the magnetic field vector at the center of the magnet segment is radial. As discussed in more detail below, in other instances, the magnetic field vectors can be normal to radial or arcuate having the same center as the rotor. Alternatively, as illustrated in FIG. 2U, a magnet segment **204** with a true radially-directed magnetic field possesses a magnetic field with magnetic field direction vectors that are each radial. In instances where the outer surface the magnet segment is an arc in the round outer surface of a circular rotor, the magnetic field direction vectors can be normal to the outer surface **268** of the magnet segment. In uniform magnetic segments, the magnetic field direction vectors can be configured to all be perpendicular to the mating flat surfaces of the magnet segment and rotor hub. In radial magnetic segments, the magnetic field direction vector at the center line of the magnetic segment can be configured to be perpendicular to the mating flat surfaces of the magnet segment and rotor hub.

[0141] Returning to FIG. 2H, disposed between the two poles are interpole magnet segments **204h**, **204t**. Interpole magnet segments **204h**, **204t** can be provided to adjust the magnetic flux distribution of the rotor **200**, transitioning the magnetic field between the two poles. In the implementation pictured in FIG. 2H the interpole magnet segments **204h**, **204t** possess geometries similar to the radial magnet segments **204a-g**, **204j-s**, the interpole magnet segments having magnetic fields directed normal to these radial fields, or tangent to circumference of the rotor **200**.

[0142] The arrangement of permanent magnet segments on the rotor hub **202** can result in a net magnetic pole center vector **270** for the rotor **200**. In the example of FIG. 2H, the magnetic pole center has a direction vector component centered on magnet segment **204d**, the geometric center of the rotor's north pole. The rotor illustrated in FIG. 2H has a regular pole center. The pole center **270** of the rotor **200** illustrated in FIG. 2P is also regular. As illustrated in FIG. 2P, the pole center vector **270** is aligned between magnet segments **204b** and **204c**, this interface representing the geometric center of the top pole in rotor **200**. Where the magnetic pole center **270** is aligned with the geometric midpoint of the array of magnet segments establishing a north (or south) magnetic pole, the pole center is regular. FIG. 2K, on the other hand, illustrates an example of a rotor with an irregular pole

center 270. The geometric center of rotor 200 in FIG. 2K, is the arcuate midpoint of magnet segment 204d. As illustrated, pole center 270 in FIG. 2K is not aligned with the geometric center of the rotor. Depending on the design of the stator, and the objectives for the electric machine, it can be desirable to implement rotors with either a regular or irregular pole center vector.

[0143] FIG. 2I illustrates a cross-sectional view of another rotor magnet configuration. The structural dimensions of the rotor magnet configuration of FIG. 2I can be substantially similar to the structural dimensions of the rotor magnet configuration of FIG. 2H. The configurations of FIGS. 2H and 2I can have the same number of magnet segments, the magnet segments having substantially identical physical dimensions. However, while FIG. 2H illustrates an example two-pole rotor design, FIG. 2I illustrates an example four-pole design. The first pole of FIG. 2I includes magnet segments 204a, 204b, 204c, the second pole includes magnet segments 204e, 204f, 204g, the third pole with magnet segments 204j, 204k, 204m, and the fourth pole with 204p, 204q, 204s. At least one interpole magnet segment 204d, 204h, 204n, 204t can be provided for each pole in the configuration, the interpole magnet segments 204d, 204h, 204n, 204t positioned between two adjacent poles. Interpole magnet segments 204d, 204h, 204n, 204t can have magnetic fields directed approximately normal to the radial fields of the remaining magnet segments. In certain instances, half of the interpole magnet segments 204h, 204t can have magnetic fields directed in the clockwise direction, the other interpole magnet segments 204d, 204n can have fields directed in the counter-clockwise directions.

[0144] While FIGS. 2H and 2I are each implemented with sixteen magnet segments per row (or sixteen hub facets and equivalently shaped magnet segments), other rotor designs employing permanent magnet segments may also be provided. For example, more or fewer than sixteen facets can be employed, including facets with varying geometries. For example, geometries can be employed, such as those described above in connection with FIGS. 2Q and 2R, providing flow path channels between adjacent magnet segments. In some instances the outer surface of the magnet segment can be flat, as opposed to round as in FIGS. 2H and 2I. The magnet segment's interface with the rotor hub can also affect its geometry (as in the case of a facet, as shown, for example, in FIGS. 2G-2R). Indeed, alternative configurations, numbers of facets, and geometries can be employed as substitutes for other rotor designs with comparable magnetic profiles. For example, a substitute for the two-pole rotor illustrated in FIG. 2H can be achieved using only four circumferential magnet segments mounted to the rotor hub 202, as illustrated in FIG. 2J. Two pole magnet segments 204w, 204y can be employed for the north and south poles of the rotor, with two, additional interpole magnet segments 204x, 204z disposed between the magnet segments 204w, 204y. Given that the pole segments 204w, 204y are the primary magnetic segments for the rotor 200, some implementations, including the example illustrated in FIG. 2J, may provide for polar segments 204w, 204y with longer arcuate spans than the transitional interpole magnet segments 204x, 204z. Additionally, the outer surfaces of the magnet segments, when mounted on the rotor hub 202, can form a cylindrical outer surface of the rotor 200, as also illustrated in the sixteen facet example of FIG. 2H. While the four magnet segment rotor of FIG. 2J has two poles, as in FIG. 2H, the FIG. 2J rotor may have a magnetic profile and performance characteristics distinct

from those of the sixteen facet rotor of FIG. 2H. Additionally, other configurations, employing the principles illustrated in the examples of the FIGS. 2H and 2J, are within the scope of the disclosure, allowing several facet-based design options tailored to the economics and performance considerations of the designer.

[0145] FIG. 2K is a cross-sectional view of yet another example two-pole magnet configuration. The two-pole magnet configuration example of FIG. 2K can employ interpole magnet segments 204h, 204t utilizing split-interpole construction. Each interpole magnet segment 204h, 204t can be constructed of two separate magnet pieces 254, 256, bonded together to form a single magnet segment. Radial magnet segment piece 254 can be a magnet with a radially-oriented magnetic field. Magnet segment piece 254h belonging to interpole magnet segment 204h can have a radial magnetic field directed away from the center of the rotor hub 202. Magnet segment piece 254t belonging to interpole magnet segment 204t can then have a radial magnetic field directed toward the center of the rotor hub 202. Normal magnet segment pieces 256h, 256t can be bonded to radial magnet segment pieces 254h, 254t to form respective interpole magnet segments 204h, 204t. Normal magnet piece 256h, bonded to radial magnet piece 254h, can have a magnetic field directed normal to the radial magnetic field of piece 254h, and oriented in a counter-clockwise direction. Normal magnet piece 256t, bonded to radial piece 254t, can have a magnetic field normal to the radial direction, the field of normal piece 256t oriented in the clockwise direction. Magnet pieces 254, 256 can be constructed of the same or dissimilar magnetic materials. Magnet pieces 254, 256 can be equal sizes, or alternatively, one magnet piece can be larger than the other. Selecting the materials of the magnet pieces 254, 256 as well as the size of one piece relative the other can be done to engineer the magnetic characteristics of the interpole magnet segment 204h, 204t, allowing rotor designers to refine the magnetic characteristics of the interpole magnet segments 204h, 204t and thereby modify some magnetic flux characteristics of the rotor.

[0146] As shown in FIG. 2L, split-interpole magnet segment designs similar to that described above with the example of FIG. 2K can also be employed in magnet configurations with more than two poles. For example, split-interpole magnet segments 204d, 204h, 204n, 204t can be employed in four-pole magnet configurations similar to, for example, the four-pole magnet configuration described in FIG. 2I.

[0147] Rotor hub 202 magnet configurations can employ more than one interpole magnet segment per pole. The rotor hub 202 examples illustrated in FIGS. 2H-2I can form the base for building numerous, varied magnet configurations by mounting varied combinations of modular magnet segments 204a-t on the hub 202 with varying magnetic field orientations, magnetic material characteristics, and material densities. For example, the four-pole configuration example of FIG. 2I can be modified by replacing radially-oriented magnet segments 204a, 204c, 204e, 204g, 204j, 204m, 204p, 204s with non-radial magnet segments, as shown in FIG. 2M, so that adjacent magnet segments 204a-c, 204e-g, 204j-m, 204p-s possess parallel-oriented magnetic fields. As shown in FIG. 2N, other implementations may alter the four-pole configuration of FIG. 2I, exchanging the normal-oriented interpole magnet segments of FIG. 2I with interpole magnet segments 204d, 204h, 204n, 204t possessing magnetic fields

oriented with directional vectors approximating the vector sum of the two magnet segment pieces of the split-interpole magnet segments of FIG. 2L.

[0148] Yet another example illustrating the broad compatibility of the rotor hub 202 and modular magnet segments 204a-t, is shown in FIG. 2O. A two-pole magnetic configuration with uniform magnetization can be constructed with magnet segments 204a-t constructed so that the magnetic field of each magnet segment is oriented parallel to and in the same direction as every other magnet segment's magnetic field when all magnet segments 204a-t are mounted on the rotor hub 202. Depending on the configuration of the cooperating stator in the electric machine, substantially uniform rotor magnetizations, such as the two pole design of FIG. 2O, can provide more efficient electromagnetic power conversion

[0149] In addition to the two pole, uniform magnetization design of FIG. 2O, four pole uniform rotor designs are attainable using the facet-based approach described. For example, in FIG. 2P, a sixteen facet rotor is provided. In the example of FIG. 2P, the first pole includes magnet segments 204a, 204b, 204c, and 204d. The magnetic field direction vectors of each of the magnet segments in this first pole, when mounted to the rotor hub 202 are parallel to the magnetic field direction vectors of the others magnet segments in the pole. Such is also the case in the other three poles of the rotor example of FIG. 2P. A second pole can include magnet segments 204j, 204k, 204l, and 204m. The second pole magnet segments in this example, have magnetic field direction vectors parallel to the magnetic field direction vectors of the first pole, but oriented in the opposite direction to the first pole magnet segments' magnetic fields. Third and fourth poles are provided, each with magnetic field direction vectors orthogonal to the magnetic fields of poles one and two. The third pole can include magnet segments 204e, 204f, 204g, 204h. A fourth pole can include magnet segments 204n, 204p, 204q, 204r. The magnetic field direction vectors of the third and fourth poles are also parallel and opposite to one another.

[0150] The examples illustrated in FIGS. 2H-2R and discussed above are not intended to limit the possible magnetic configurations contemplated for the rotor hub 202. Indeed, several additional implementations and magnet configurations can also be implemented to meet a wide array of magnetic and structural characteristics for particular rotor applications. The facet-based rotor concepts described above can be used to develop a versatile variety of potential rotor configurations. Indeed, where a common rotor hub geometry is employed by a rotor manufacturer, common magnet segment geometries can be employed across rotor designs, allowing the designer to build nearly limitless rotor variations by interchanging magnet segments having the appropriate magnetic field vectors. Additionally, where rotor hubs 202 are employed allowing for magnet segments with equal arcuate span, fabrication of the magnet segments and the required magnet segment combinations can be simplified, in that only magnet segments of a single geometry need to be fabricated. Additionally, in designs employing magnet segments with the fewest different magnetic profiles, the number of different magnet segments that need to be manufactured and stocked can be further minimized, allowing rotor designers to provide a range of rotor products while minimizing supply chain and manufacturing costs, among other advantages.

[0151] Referring now to FIG. 3A, an example electric machine 319 is shown. The electric machine 319 is similar to and may be used as the electric machine 102a shown in FIG.

1B. The electric machine 319 includes a housing 314 defining an interior 308. A rotor 306 is rotatable relative to the stator 300 and disposed in the interior 308 thereof. There is a gap 310 between the stator 300 and rotor 306. The example stator 300 includes an electromagnetic winding 302 mounted on a cylindrical stator core 304. The stator 300 is suitable for use as stator 108 above. Some implementations of the winding 302 can be configured for the electric machine to function as a synchronous, AC electric machine. Some implementations of the winding 302 can include two-pole windings, forming a three phase electromagnet. Other implementations are possible as well, depending on the electric machine application, including four-pole windings, single-phase windings, and other winding configurations.

[0152] The winding 302 can be constructed by winding cable or formed conductors through stator core slots to form the winding loops or coils. The stator core 304 can be constructed of metallic, laminated plates, bonded together to form the core structure. The materials used in stator core 304 plates can be selected so as to adjust the electromagnetic flux characteristics of the winding 302 wound around the core slots. The core material can be selected also by considering the material used in the cable of the winding, so as to achieve a desired electromagnetic stator profile. For example, copper-based, insulated cables can be used for the winding 302. The cable can be wound around a core 304 built of steel plates laminated together with a silicon-based, low-loss laminate. It is contemplated that the slots of the stator core 304, as described in more detail below, can be implemented using a variety of slot shapes and sizes. The selection of the slot geometry can be based on the cable type (or types) used in the windings. Additionally, the winding 302 can be constructed as form-wound or random-wound coils. In certain instances, the windings 302 result in winding end turns 312 positioned on the axial ends of the stator core 304. As set forth in more detail below, various end turn winding techniques can be used to provide for end turns 312 with the particular structural and electromagnetic characteristics desired for a certain particular stator design.

[0153] Some implementations of the stator 300 can be adapted for subsea and/or corrosive environment operation. For example, certain instances of the stator 300 can be sealed or otherwise protected from exposure to heat transfer fluids, process fluids, other corrosive or harmful matter and/or other foreign matter by providing a protective barrier 316 around the stator 300 or otherwise sealing the stator 300. For example, certain instances of the electric machine system may provide for a "flooded" system. A protective barrier 316 can be provided to guard against corrosion of elements of the stator 300 while allowing the fluid provided in the electric machine system to cool the stator 300. Other implementations may provide a coating, or other seal on the stator, so as to seal the stator 300 from exposure or corrosion. For example, some or all of the stator can be coated or treated for corrosive resistance with epoxy, polyetheretherketones, ethylene chlorotrifluoroethylene copolymer and/or other treatments. Some implementations of stator 300 can be provided with protective coverings that provide rigid structural support as well as protection.

[0154] The stator, such as the stator shown in FIG. 3A, may be formed from a stator core and windings 302 extending through the stator core. An example stator core 335 is shown in FIG. 3B. The stator core 335 is formed from a plurality of adjacent yokes 303 (i.e., a stator stack) extending in a longi-

tudinal direction 305 bounded at opposing ends by end plates 307. Further, a plurality of stator bars 309 extend in the longitudinal direction 305 and are operable to axially, radially and circumferentially align the yokes 303. A plurality of teeth 301 are retained within slots or channels formed by the yokes 303, which is discussed in more detail below. See, e.g., FIG. 3G

[0155] FIG. 3C illustrates a stator stack 325 formed from a pair of adjacent yokes 303. The stator stack 325, shown without stator teeth and electromagnetic windings, is discussed in more detail below. According to some implementations, a stator 300 may include a stack of eight yokes 303. Other implementations, though, may include additional or fewer yokes 303. One or more of the yokes 303 may be segmented. That is, one or more of the yokes 303 may be formed from a plurality of arc-shaped segments 315. In some implementations, all of the yokes 303 are segmented.

[0156] As shown, the yoke 303 is formed from four segments 315 and, thus, the yoke 303 is divided into quadrants. However, in other instances, the yoke 303 may be formed from more or fewer segments 315. An example segment 315 is shown in FIG. 3D in which the segment 315 is formed from a plurality of laminations 311. The illustrated example segment 315 is formed from ten laminations 311, although other implementations may be formed from additional or fewer laminations 311. In some implementations, the laminations 311 may be formed from steel, such as low-loss silicon steel. In other implementations, the laminations 311 may be formed from different types of steel or other types of metals, alloys, composites, or other types of suitable materials. Laminations 311 may be bonded together chemically or mechanically. For example, the laminations 311 may be bonded together with an adhesive. Alternately, the laminations 311 may be mechanically coupled by interlocking the laminations 311 with each other. In some instances, a portion of one lamination 311 may protrude into an adjacent lamination 311. Further, in some implementations, some laminations 311 may interlock with adjacent laminations 311 while other laminations 311 do not interlock with other laminations 311.

[0157] Each segment 315 includes a plurality of radially inward extending protrusions 317. The protrusions 317 define a plurality of first notches 320 formed along an interior periphery 318 of the segment 315. As shown in the illustrated example, each segment 315 includes six protrusions 317, although, in other instances, each segment 315 may include more or fewer protrusions 317 defining more or fewer first notches 320. As shown in FIG. 3C, the first notches 320 align to form at least a portion of tooth channels 321 that accept a tooth 301 (described in more detail below). Each segment 315 also includes a plurality of second notches 322 formed on an outer perimeter 324 of the segment 315. As illustrated in FIG. 3C, the second notches 322 align to form at least a portion of a channel 326 into which a stator bar 309 is retained, as illustrated in FIG. 3B. The stator bar 309 retained in the channel 326 provides alignment and structural support to the assembled stator 300.

[0158] An example stator bar 309 is illustrated in FIG. 3E. The illustrated stator bar 309 is a slender member having a constant rectangular cross-section. As also illustrated in FIG. 3C, the channels 326 also have a constant rectangular cross-section to accept and retain the stator bars 309. However, the stator bar 309 shown in FIG. 3E and the channel 326 shown in FIG. 3C are merely examples, and the stator bars 309 and channels 326 may have other cross-sectional shapes.

[0159] Referring again to FIG. 3C, the yoke 303 is assembled such that joints 313 formed at adjacent ends of the segments 315 are offset from each other so that joints 313 in adjacent yokes 303 do not align. In other implementations, though, adjacent joints 313 may align. As shown, the angular offset (θ) of joints 313 in adjacent yokes 303 is 45° , although other angular offsets may be used. In certain instances, the yokes 303 may be welded together, bonded together with an adhesive, assembled with fasteners, interlockingly coupled, and/or assembled in another manner. Still further, the assembled stator 300 and/or the stator core 335 may be coated with polyetheretherketone (“PEEK”), ethylene chlorotrifluoroethylene copolymer (“ECTFE”), oxide coating and/or another material.

[0160] FIG. 3F shows an example end plate 307 of the stator 300. The end plates 307 are disposed at opposing ends of the of the assembled stator core 335. In certain instances, the end plate 307 may be single, continuous plate. The end plate 307 also includes a plurality protrusions 331 formed in an interior periphery 332 of the end plate 307. The protrusions 331 form first notches 330 therebetween. The end plate 307 also includes a plurality of second notches 334 formed in an outer periphery 336 of the end plate 307. When combined with the stator stack and teeth 301, protrusions 331 overlay the teeth 301 that are retained in the tooth channels 321. The first notches 330 align with channels formed between the teeth 301, i.e., winding channels 350, described below. The second notches 334 align with the second notches 322 to form the channels 326. In certain instances, as shown in FIG. 3G, the tooth channels 321 may have the shape of a dovetail-type joint such that the teeth 301 and associated tooth channels 321 interlock so that the teeth 301 are locking retained therein. However, the channels 321 may form any shape that retains the teeth 301. Further, the tooth channels 321 may have a high aspect ratio in certain instances, while, in other instances, the tooth channels 321 may have lower aspect ratios, i.e., the tooth channels 321 may be shallower and wider.

[0161] Each tooth 301 may be formed from a plurality of tooth segments 338, an example of which is shown in FIG. 3H. According to the illustrated example, the tooth segment 338 has a tapered cross-section. A first end 340 of the tooth segment 338 has a dimension D1 that is larger than a dimension D2 of a second end 342 of the tooth segment 338. An end of the assembled tooth 301 corresponding to the first ends 340 of the tooth segments 338 are retained in the tooth channels 321.

[0162] In some implementations, the tooth segments 338 may be formed from a plurality of laminations 339. As shown, the example tooth segment 338 is formed from ten laminations. In other instances, the tooth segments 338 may be formed from additional or fewer laminations. The teeth 301 may be formed from tooth segments 338 having the same or approximately the same length. In other implementations, the teeth 301 may be formed from tooth segments 338 having different lengths. In some instances, the tooth segments 338 may have different lengths by having more or fewer laminations 339 than other tooth segments 338. Laminations 339 may be chemically or mechanically bonded. For example, some of the laminations 339 may be bonded together with an adhesive. In other instances, some of the laminations 339 may be interlockingly coupled. For example, a protrusion formed in one lamination 339 may be received into a receptacle formed in an adjacent lamination 339.

[0163] In some implementations, one or more of the teeth **301** may be formed from tooth segments **338** having different lengths. For example, FIG. 3K shows a schematic view of a tooth **301** extending through the channel **321**. The tooth **301** is formed from tooth segments **338a** and **338b** having different lengths. In the implementation shown, the tooth segment **338a** has a length half of the length of tooth segment **338b**. Further, the length of the yokes **303** may be the same as the length of tooth segment **338b**. As shown, the tooth **301** leads with a tooth segment **338a** abutting the end plate **307**. The tooth segment **338a** occupies half the length of the portion of the channel **321** extending through the first yoke **303**. A tooth segment **338b** is placed adjacent the tooth segment **338a**, causing the tooth segment **338b** to overlap the adjacent yoke **303**. That is, a first half of the tooth segment **338b** lies in one yoke **303** while the second half of the tooth segment **338b** extends into the neighboring yoke **303**. Overlapping of the tooth segments **338b** in the adjacent yokes **303** provides rigidity and enhances mechanical strength of the stator **300**. Although the tooth segments **338b** are described as overlapping by the adjacent yokes **303** by half, the tooth segments **338b** could overlap the adjacent yokes **303** by different amounts. For example, in some implementations, the tooth segments **338** may overlap adjacent yokes **303** in the following percentages: 60%-40%, 65%-35%, 70%-30%, or 80%-20%. However, it is within the disclosure to use any desired amount of overlap. Still further, the tooth segments **338b** may be of a length to extend partly into a first yoke **303**, extend completely through one or more adjacent yokes **303**, and partially extend into an additional yoke **303**.

[0164] Referring to FIG. 3I, each tooth segment **338** may include a protrusion **344** on first face **346** and a receptacle **348** on a second face **347**. The protrusion **344** on one tooth segment **338** is accepted into the receptacle **348** on an adjacent tooth segment **338** to provide for at least one of alignment or attachment of adjacent tooth laminations. FIG. 3J shows another configuration of the protrusions **344** and receptacles **348** formed on tooth segments **338**.

[0165] According to some implementations, the teeth **301** may be formed from a material different from one or more of the yokes **303**. Particularly, the teeth **301** may include a material that has a higher magnetic flux capacity than the material forming the yokes **303**. In certain instances, the tooth segments **338** are formed, at least in part, from a cobalt-iron alloy. For example, one or more of the laminations **339** forming the tooth segment **338** may be formed from cobalt-iron alloy, while other laminations **339** may be formed from a different material. Example cobalt-iron alloys include Hiperco, a product of Carpenter Technology Corporation, Sillectron, a product of Arnold Magnetic Technologies Corporation, and/or other alloys. Still further, the tooth segments **338** need not all be formed from the same material. That is, in some implementations, some of the tooth segments **338** may be formed from one material and other tooth segments **338** formed of different materials. In certain instances, since high magnetic flux material is typically more expensive than other materials, some portion of the tooth segments **338** (e.g., one or more segments **338** or one or more laminations **339** of one or more segments **338**) may be formed of a high magnetic saturation flux capacity material and the remainder formed of a less expensive material. In certain instances, the less expensive material may be used to form one or more of the laminations **311**. The different materials of tooth segments **338** or laminations **339** therein may be alternated in a regular or irregular

pattern over the length of the stator **300**. For example, every second, third, fourth or other specified tooth segments **338** may be formed from the higher magnetic saturation flux density material while the interstitial tooth segments **338** may be formed from less expensive, lower saturation flux density material. The resulting tooth **301** has a higher composite magnetic saturation flux capacity than the less expensive material alone, but cost less than a tooth **301** made entirely of the higher magnetic flux capacity material. In some implementations, the high magnetic saturation flux material may be distributed through the stator **300** so that the ends of the stator **300** have a relatively low magnetic saturation flux density. In other instances, the ends of the stator **300** may have the lowest magnetic saturation flux density.

[0166] In another example, the types of materials of the tooth segments **338** (including the materials of the laminations **339** of the tooth segments **338**) at different locations along the tooth **301** can be selected to achieve a desired temperature distribution across the length of the stator **300** and/or to compensate for variations in heat extraction and/or generation along the length of the stator **300**. In certain instances, the materials of the tooth segments **338** can be configured to achieve a uniform temperature distribution or a more uniform temperature distribution across the length of the stator **300** than achieved with tooth segments **338** of uniform material type. For example, a higher density (number per unit length) of higher magnetic flux material tooth segments **338** can be provided in areas of the stator **300** with less cooling heat transfer. By increasing the magnetic flux capacity in these areas, less heat is generated and the lesser cooling can be at least partially offset. Similarly, in areas with greater cooling heat transfer, a lower density of higher magnetic flux material tooth segments **338** can be provided. In certain instances, for example, where the heat transfer fluid is introduced through the ends of the rotor and stator **300**, the tooth segments **338** or portions thereof near the axial center of a tooth **301** can have a higher density of higher magnetic flux density material than tooth segments **338** near the ends of the tooth **301** to offset the lower heat transfer at the axial center of the stator **300**.

[0167] Referring again to FIG. 3G, the laminated teeth **301** are inserted into respective tooth channels **321**, as explained above. The assembled stator **300** includes channels **350** that are formed between adjacent teeth **301**. Cable and/or formed conductors may be fed through or placed into these winding channels **350** to form windings of the stator **300**.

[0168] As described, the assembled stator **300** (shown in FIG. 3B) provides a stator core that can achieve a higher flux density than if the teeth and yoke portions were made from the same material. Further, such a construction results in a cost savings by using more expensive materials in only certain places, such as in the tooth region, where enhanced magnetic flux density is needed and not in less critical areas, such as the yoke. Further, construction of the yoke **303** from the plurality of segments **315** provides for less waste in manufacturing. Particularly, when producing the laminations **311**, **339** to form the segments **315** or tooth segments **338**, respectively, from sheet material, the laminations **311** and **339** may be arranged more densely on the sheet, leaving less waste. Additionally, the tooth segments **338** and yoke segments **315** can be mass produced to further reduce manufacturing costs.

[0169] A stator of an electric machine, such as the stator **300** described above, may be assembled in an number of different manners. In certain instances, the stator core **335**

may be assembled by joining the four yoke segments **315** to form a yoke **303** and joining the appropriate number of teeth segments **338** to the yoke **303** and then joining the resulting assemblies to one another, along with the end plates **307**, to form the stator core **335**. In certain instances, the stator core **335** may be assembled by forming complete teeth **301** (i.e., by joining the teeth segments **338** together to form complete teeth **301**) and a complete stator stack (i.e., by joining together the plurality of yokes **303**) and then assembling the completed teeth **301** to the completed stator stack and adding the end plates **307** to form the stator core **335**. In certain instances, the stator core **335** may be assembled in another fashion. The windings **302** may be wound to the stator core **335** in a number of different manners. In certain instances, the windings **302** may be wound to the completed teeth **301** (e.g., the teeth **301** held in position relative to one another with a fixture) prior to assembly into the stator stack. In certain instances, the windings **302** may be wound to the completed stator core **335**, i.e., after the stator stack and teeth **301** are assembled together. The assembly of the windings **302** and teeth **301** and/or the entire assembled stator **300** may be vacuum-pressure impregnated with a coating material and baked, for example, to achieve desired mechanical and electrical properties. In certain instances, locking plates may be attached to the ends of the stator stack to secure the teeth **301** to the stator stack.

[0170] As mentioned above, construction of the stator **300** permits the use of different materials between the teeth and the yoke. Such a construction allows optimization of flux density and reduction in losses and related construction costs. This assembly process has the further benefits of using winding techniques not otherwise achievable. Further, windings formed in this way may have attached thereto cooling devices. Such a combination would not otherwise be possible with traditional winding techniques.

[0171] FIGS. 3L-3Q illustrate implementations of the protective barrier **316** formed around a stator, such as the stator **300** or **108** of an electric machine, such as the electric machine **102**. The protective barrier **316** forms a stator cavity **353** in which the stator **300** resides. The stator cavity **353** may or may not be filled with a fluid. FIG. 3L shows a cross-sectional view of an example electric machine, which may be similar to the electric machine **102**. The electric machine includes a housing **314**, the stator **300**, the rotor **306**, and the protective barrier **316**. The protective barrier **316** may also prevent intrusion of fluid passing through the electric machine **102** into the stator cavity **353**. The protective barrier **316** has a cylindrical shape, a closed end **354** at an inner radius, and an open end **356** at an outer radius. The closed end **354** is formed by a cylinder **358**, and the open end **356** is defined by side flanges **360**. The side flanges **360** abut and/or are attached to the housing **314**. As explained above, the protective barrier **316** provides protection for the stator **300**, for example, in flooded applications in which the electric machine **102** has fluid (represented by arrows **362**) passing therethrough between the rotor **306** and the stator **300**. Accordingly, the protective barrier **316** provides protection against exposure of the electric machine and its components to the fluid (e.g., sea water, cooling fluids, process fluids) or other foreign matter passing through the electric machine.

[0172] Additionally, the protective barrier **316** protects the electric machine by preventing contact between the stator **300** and the rotor **306**. Further, the protective barrier **316** may be formed of a material resistant to corrosion and/or abrasion,

such as abrasion and/or corrosion that may be caused by the fluid (including any particulates and/or contaminants contained therein) passing through the electric machine **102** between the stator **300** and the rotor **306**. The protective barrier **316** may also be constructed to withstand pressure changes between the fluid passing through the electric machine and any fluid contained in the stator cavity **353**. The protective barrier **316** may also be constructed to accommodate thermal expansion and contraction of the housing **314** and the stator **300**.

[0173] FIG. 3M shows a partial cross-sectional view of an example electric machine. As shown, the cylinder **358** of the protective barrier **316** includes a first portion **364** and an abutting second portion or ring **366**. In certain instances, the cylinder **358** can be a common commercially available preformed tubing. According to some implementations, a first edge **368** of the first portion **364** of the cylinder **358** may include an outwardly flared portion **370** and a tapered portion **372**. The tapered portion **372** extends from the outwardly flared portion **370**. The tapered portion **372** is accepted into a tapered channel **374** formed in one of the side flanges **360**. The tapered portion **372** and the tapered channel **374** may be fit together to provide a seal. For example, the tapered portion **372** and the tapered channel **374** may be fit together with an interference fit. In certain instances, the seal prevents the passage of fluid. Further, the tapered channel **374** includes at least one opening **376** extending from an inner portion of the tapered channel to the atmosphere or to the stator cavity **353**, for example. The at least one opening **376** allows air to escape from the channel during assembly of the tapered portion **372** into the tapered channel **374**, thereby providing a secured attachment.

[0174] A first edge **378** of the ring **366** may also be tapered and, similarly, may be accepted into another tapered channel **374** formed in a second of the side flanges **360**. The first edge **378** of the ring **366** and the tapered channel **374** may also be fitted together with an interference fit to provide a seal against intrusion of fluid. Also, as described above, the tapered channel **374** may include one or more openings **376**, described above, to provide escape of air from the tapered channel **374** (i.e., pressure equalization) during assembly of the first edge **378** and the tapered channel **374**.

[0175] Second edges **382** and **384** of the first portion **364** and ring **366**, respectively, overlap to form a tapered joint **386**. Particularly, in some implementations, adjacent surfaces of the second edges **382**, **384** of the first portion **364** and the ring **366**, respectively, overlap and abut against each other to form the tapered joint **386**. The tapered joint forms a seal to prevent passage of fluid. In certain instances, the second edge **382** of the first portion **364** may flare outwardly. The tapered joint **386** allows dimensional variations of the protective barrier **354** while still maintaining a seal to prevent intrusion of fluid into the stator cavity **353**. For example, during operation of the electric machine **102**, components of the electric machine **102** may experience expansion and/or contraction, such as due to rotational speeds and/or temperature changes and the tapered joint **386** may remain engaged. In certain instances, the tapered joint **386** may form a water-tight seal. Further, a contact pressure between the first portion **364** and the ring **366** at the tapered joint **386** may increase with expansion of the housing **314**. Alternately, the tapered joint **386** may be configured such that the pressure of the tapered joint **386** may increase with contraction of the housing **314**.

[0176] According to some implementations, either or both of the first portions 364 or ring 366 of the cylinder 358 (i.e., the portion proximate the permanent magnets of the rotor), may be formed from a fiber and polymer composite material. In certain instances, the cylinder 358 may be formed from a carbon or glass fiber composite material provided in a thermoplastic or thermosetting matrix. Such materials provide high strength, corrosion resistance, and abrasion resistance and are not magnetically permeable. In certain instances, the side flanges 360 may be formed from a metal.

[0177] FIG. 3N shows another implementation of the protective barrier 354 without a tapered joint. In such an implementation, the cylinder 358 includes opposing tapered edges 388 are accepted into flared channels 374. The tapered edges 388 and the tapered channels 374 may also form an interference fit to create a seal. In certain instances, the seal may be a water-tight seal to prevent intrusion of fluid. Also, as explained above, the tapered channels 374 may include one or more openings 376 to provide pressure equalization during assembly. Further, the cylinder 358 may be formed from a composite material, as described above, and the fibers of the composite may be oriented and/or the matrix material selected such that the coefficient of thermal expansion of the cylinder 358 matches the coefficient of thermal expansion of the housing 314, thereby eliminating the need for a tapered joint. In certain instances, the cylinder 358 can be a common commercially available pre-formed tubing.

[0178] The implementation shown in FIG. 3O shows a protective barrier 354 formed from a composite material having a coefficient of thermal expansion that matches that of the housing 314. In this implementation, the cylinder 358 has an integrated side flange 392 and a tapered edge 388. As explained above, the tapered edge 388 may be fitted into the tapered channel 374 to provide an interference fit. Pressure may be equalized in the tapered channel 374 and the atmosphere via one or more openings 376 formed in the side flange 360 from the tapered channel 374 and the stator cavity 353. The integrated side flange 392 may be secured directly to the housing 314 by a ring 394 that may also function to protect an outer edge 396 of the integrated side flange 392. In certain instances, the ring 394 may be formed from metal.

[0179] FIGS. 3P and 3Q show additional alternate implementations of the protective barrier 354. The protective barriers 354 illustrated in these implementations may also be formed from a composite material designed to have a coefficient of thermal expansion that matches that of the housing 314. As shown in FIG. 3P, the cylinder 358 of the protective barrier 354 may include a lip 398 that includes an outer surface 391 that abuts an inner surface 393 of the side flange 360. A ring 395 may be used to clamp the cylinder 358 in place such that the lip 398 is sandwiched between the ring 395 and the side flange 360. In some implementations, the ring 395 and the side flange 360 may be formed from metal, and, in still other implementations, the ring 395 and side flange 360 may be formed from the same type of metal. One or more fasteners may be used to secure the ring 395, cylinder 358, and side flange 360 together. Alternately or in combination, an adhesive may be used.

[0180] FIG. 3Q shows another implementation in which an inner surface 381 of the cylinder 358 at outer edges 397 abut an outer surface 383 of the side flanges 360. A ring 385 may be used to secure the cylinder 358 to the side flanges 360 at the outer edge 397. In some implementations, fasteners and/or an adhesive may be used to secure the ring 385, cylinder 358, and

side flanges 360 together. In addition to these methods or alternatively, the ring may have a slightly larger outer diameter than an inner diameter of the cylinder 358. Thus, the ring 395 and cylinder 358 may be held in place relative to the side flange 360 by friction caused by an interference fit. Also, the ring 385 and the side flanges 360 may be formed from a metal, and, in still other instances, the ring 385 and the side flanges 360 may be formed from the same type of metal.

[0181] FIG. 4A is a partial schematic end view of an example core 400 of a stator for an electric machine. The example core 400 is suitable for use in the stator 108 of electric machine 102. The core 400 defines a substantially cylindrical inner volume to receive a rotor of an electric machine. The core 400 includes teeth 402 extending radially from a yoke 422 of the core to an outer circumference of the inner volume of the core. The teeth define slots 404 to receive conductive windings. For example, neighboring teeth 402a and 402b define slot 404a, and neighboring teeth 402b and 402c define slot 404b. Each tooth 404 has a tip 420. As shown, for example in FIGS. 4A, 4B, and 4C, a stator can have slots between each pair of teeth, where each slot has a slot region with parallel slot sides and each tooth has a tooth section with parallel tooth sides.

[0182] Each tooth 402 has a radial length extending from the yoke 422 to the tip 420 of the tooth. For example, tooth 402a has a radial length extending from the yoke 422 to tip 420a, and tooth 402b has a radial length extending from the yoke 422 to tip 420b. In the illustrated example, all of the teeth 402 have the same radial length. In some implementations, some of the teeth 402 have unequal radial lengths. Each slot 404 has a radial depth extending from the yoke 422 to the inner volume. The radial depth of a slot 404 can be defined by the yoke 422 and the sides of the teeth 402 that define the slot 404. For example, the radial depth of the slot 404a is defined by the yoke 422 and the sides of the teeth 402a and 402b, and the radial depth of the slot 404b is defined by the yoke 422 and the sides of the teeth 402b and 402c.

[0183] Each tooth 402 has a width along the radial length of the tooth 402. For example, the width of a tooth at a given point is related to the azimuthal angle spanned by the tooth at the given point. A tooth 402 may have a first radial section where the tooth width is constant or substantially constant along the radial length of the tooth 402. As such, a tooth can have parallel tooth sides in at least a section of the tooth. A tooth 402 may have a second radial section where the tooth width varies along the radial length of the tooth 402. As such, a tooth can also have non-parallel sides in at least a section of the tooth. The tooth width may vary linearly and/or non-linearly along the radial length of the tooth in the second radial section. The radial length and the width of a tooth can determine an area of the tooth. For example, the area of a tooth may be calculated as an integral of the tooth width over the radial length of the tooth.

[0184] Each slot 404 has a width along the radial depth of the slot 404. For example, the width of a slot at a given point is related to the azimuthal angle at the given point between the two teeth 402 that define the slot 404. A slot 404 may have a first radial section where the slot width is uniform or substantially uniform along the radial depth of the slot 404. As such, a slot can have parallel slot sides in at least a region of the slot. A slot 404 may have a second radial section where the slot width varies along the radial depth of the slot 404. As such, a slot can also have non-parallel sides in at least a region of the slot. The slot width may vary linearly and/or non-linearly

along the radial depth of the slot in the second radial section. The radial depth and the width of a slot can determine an area of the slot. For example, the area of a slot may be calculated as an integral of the slot width over the radial depth of the slot.

[0185] The geometry (e.g., length, depth, width, area) of the teeth **402** and the slots **404** can influence performance and efficiency aspects of the stator (and hence, of the electric machine). The geometry of a slot **404** can influence the position, distribution, and/or cross-sectional area of the conductive coils that can be installed in the slot. A ratio of slot area to tooth area of the core **400** may influence a maximum power, a power factor, and/or an efficiency achievable with the core **400**. Teeth with a first radial section where the tooth width varies along the radial length of the tooth and a second radial section where the tooth width is uniform along the radial length of the tooth may define slots with a first radial section where the slot width varies or is uniform along the radial depth and a second radial section where the slot width varies. Slots with a first radial section where the slot width varies along the radial depth and a second radial section where the slot width is uniform along the radial depth can improve the performance and/or efficiency of the electric machine. A core having this type of slot may balance a utilization of a stator core material (e.g., iron or another material) and a conductive winding material (e.g., copper, or another material). For example, slots with a first radial section where the slot width varies along the radial depth and a second radial section where the slot width is uniform along the radial depth can allow a larger cross-sectional area of conductive material in a portion of the slot, and can prevent excess iron in various portions of the tooth (e.g., the “root” of the tooth near the yoke **422**). Slots having this configuration may accommodate both cable windings (e.g., in the first section) and formed windings (e.g., in the second section). In some cases, excess core material at a tooth root includes magnetically under-utilized material. In some cases, increasing flux density at the tooth tip **420** limits the flux loading of the electric machine and allows excessive flux leakage path across the slot **404**, which may degrade machine performance.

[0186] In the example core **400** of FIG. 4A, all of the teeth **402** and slots **404** are identical. The radial section **406b** of the tooth **402b** has a width that varies along the radial length of the tooth **402b**, and the radial section **410b** of the tooth **402b** has a uniform width along the radial length of the tooth **402b**. The radial section **408b** of the slot **404b** has a uniform width along the radial depth of the slot **404b**, and the radial section **412b** of the slot **404b** has a width that varies along the radial length of the slot **404b**. The cross-section of each slot **404** has two rounded corners at the yoke **422**. The rounded corners can accommodate coils having a round cross-section, such as the cable winding coils shown in FIG. 4B. Each tooth **402** in FIG. 4A has a broad tip **420** that may enhance the flux and/or other properties of the core **400**.

[0187] FIG. 4B is a partial schematic end view of the example core **400** of FIG. 4A. FIG. 4B illustrates example conducting coils installed in the slot **404b**. The illustrated coils are the coils of cable windings. Coils **414a**, **414b**, **414c**, and **414d** reside in the section **408b** of the slot **404b**. Coils **414e**, **414f**, **414g**, **414h**, **414i**, **414j**, **414k**, and **414l** reside in the section **412b** of the slot **404b**.

[0188] FIG. 4C is a partial schematic end view of an example core of a stator for an electric machine. The example core **400** can be the core of the stator **108** of electric machine **102**. In the example core **400** of FIG. 4C, all of the teeth **402**

and slots **404** are identical. The radial section **406b** of the tooth **402b** has a width that varies along the radial length of the tooth **402b**, and the radial section **410b** of the tooth **402b** has a uniform width along the radial length of the tooth **402b**. The radial section **408b** of the slot **404b** has a uniform width along the radial depth of the slot **404b**, and the radial section **412b** of the slot **404b** has a width that varies along the radial length of the slot **404b**. The cross-section of each slot **404** has two substantially square corners at the yoke **422**. The substantially square corners can accommodate coils having a cross section with square corners, such as the formed winding coils **416** shown in FIG. 4C.

[0189] FIG. 4C illustrates example conducting coils installed in the slot **404b**. Some of the illustrated coils are the coils of formed windings, and some of the illustrated coils are the coils of cable windings. Formed winding coils **416a** and **416b** reside in the section **408b** of the slot **404b**. Cable winding coils **414** reside in the section **412b** of the slot **404b**. Each tooth **402** in FIG. 4C has a narrowed tip **420** that may enhance the flux and/or other properties of the core **400**.

[0190] FIG. 4D is a partial schematic end view of an example core **400**. FIG. 4D illustrates example angular parameters where each tooth includes two sections having non-parallel sides. A first section of each tooth has non-parallel sides at a first angle, and second section of each tooth has non-parallel sides at a second angle. The first angle and the second angle are different. In the example shown, the first angle is 1.9 degrees, and the second angle is 0.7 degrees larger than the first angle (i.e., 2.6 degrees). Other angles and/or angle differences may be used.

[0191] FIG. 4E is a partial schematic end view of an example core of a stator for an electric machine. The example core **400** can be the core of the stator **108** of electric machine **102**. In the example core **400** of FIG. 4E, all of the teeth **402** and slots **404** are identical. The radial section **406b** of the tooth **402b** has a uniform width along the radial length of the tooth **402b**, and the radial section **410b** of the tooth **402b** has a width that varies along the radial length of the tooth **402b**. The radial section **408b** of the slot **404b** has a width that varies along the radial depth of the slot **404b**, and the radial section **412b** of the slot **404b** has a uniform width along the radial length of the slot **404b**. The cross-section of each slot **404** has two substantially rounded corners at the yoke **422**. The substantially rounded corners can accommodate coils having a round cross section, such as the rounded coils of cable windings.

[0192] In FIG. 4E, some of the illustrated coils are the coils of formed windings, and some of the illustrated coils are the coils of cable windings. Cable winding coils **414** reside in the section **408b** of the slot **404b**. Formed winding coils **416c** and **416d** reside in the section **412b** of the slot **404b**. Each tooth **402** in FIG. 4E has a narrowed tip **420** that may enhance the flux and/or other properties of the core **400**.

[0193] FIG. 4F is a schematic end view of example end turns of a stator **450** for an electric machine. The example stator **450** can be used for the stator **108** of electric machine **102**. Only the end turns **452** of the stator **450** and a portion of the core **454** of the stator **450** are illustrated in FIG. 4F. The stator **450** includes other parts that are not illustrated in FIG. 4F.

[0194] The stator **450** includes formed windings. The coils of the formed windings include axial sections (not illustrated in FIG. 4F) that extend the axial length of the stator core. The coils of the formed windings include multiple end turns **452**

that form an end turn bundle beyond the axial end of the stator core. The end turn bundle includes two groups of end turns **452** that form four interleaved radial layers **464** of end turns **452**. Each group forms two of the four layers **464**. One layer in each group is radially between the two layers of the other group.

[0195] The stator **450** includes a core **454** that defines an inner bore **451**, which is a substantially cylindrical inner volume to receive a rotor of an electric machine. As shown in FIG. 4G, the core **454** has multiple teeth **456** extending radially inward, toward the bore **451**; the teeth **456** define slots **458** to receive conductive windings (e.g., formed windings, cable windings, or another type). The coils of the windings include axial sections (not shown in FIG. 4G) that span an axial length of the core. Each axial section may extend between the two axial ends of the core. The coils of the windings include end turns **452** extending beyond the axial end of the core. Each end turn **452** connects two axial sections of a coil. The axial sections of one or more coils may reside in each slot. Each end turn **452** has a first end connecting to a first axial section and a second end connecting to a second axial section. As shown in FIG. 4G, the first end of each end turn connects at a first circumferential location, and the second end of each end turn connects at a second circumferential location. In the implementation shown in FIG. 4G, the first end connects at a first radial distance from the radial center of the core, and the second end connects at a second radial distance from the radial center of the core. In some implementations, both ends of an end turn connect to axial sections of a coil at the same radial distance from the center of the core.

[0196] An end turn bundle, as illustrated in FIG. 4F, can include multiple groups of end turns **452**. Each group of end turns **452** can form layers **464** at different radii around the radial center of the core **454**. A single end turn **452** primarily resides in two layers formed by one of the groups. For example, an end turn **452a** has a first portion in a layer **464a**, and the end turn **452a** has a second portion in a different layer **464c**. As another example, an end turn **452b** has a first portion in a layer **464b**, and the end turn **452b** has a second portion in a different layer **464d**. The layers **464a** and **464c** are formed by a first group of end turns **452** radially positioned as the end turn **452a**. Each end turn **452** in the first group is offset circumferentially from the other members of the first group. The layers **464b** and **464d** are formed by a second group of end turns **452** radially positioned as end turn **452b**. Each end turn **452** in the second group is offset circumferentially from the other members of the second group. Layer **464a** is radially inside of layer **464b**; layer **464b** is radially inside of layer **464c**; layer **464c** is radially inside of layer **464d**. Thus, the first group of end turns (radially configured as end turn **452a**) and the second group of end turns (radially configured as end turn **452b**) are interleaved to form four layers of end turns.

[0197] Each end turn **452** passes through a planar cross-section parallel to the end of the core **454**. Each end turn **452** of the first group of end turns forms two layers of end turns, passing through the planar cross-section at a first radius and a third radius. The first radius is less than the third radius. Each end turn **452** of the second group of end turns forms two different layers, passing through the planar cross-section at a second radius and a fourth radius. The second radius is less than the fourth radius. The first group of end turns and the second group of end turns are interleaved, such that the second layer is between the first layer and the third layer (i.e., the first radius is less than the second radius, and the second

radius is less than the third radius) and the third layer is between the second layer and the fourth layer (i.e., the second radius is less than the third radius, and the third radius is less than the fourth radius).

[0198] Each end turn **452** extends between the two ends of the end turn to form a partial loop extending from the core **454**. In some implementations, when two groups of end turns are interleaved, each end turn in one group passes through the partial loop formed by one or more of the end turns in the other group. For example, the end turn **452a** passes through the partial loop formed by the end turn **452b**.

[0199] In some cases, an end turn bundle including two groups of end turns that form four interleaved radial layers of end turns can form an end turn bundle that is longitudinally shorter than other configurations. For example, if the two groups of end turns were not interleaved, and instead the two groups formed fewer than four layers of end turns, the end turn bundle may be almost twice as long as the four-layer bundle. A longer end turn bundle consumes more axial space in the electric machine, and may cause the rotor bearing journals to be positioned farther apart. A shorter end turn bundle consumes less axial space in the electric machine, and may allow the rotor bearing journals to be positioned closer together. When the rotor bearing journals are axially closer together, the bearing journals may suffer less stress and damage and/or provide better stability for the rotor. Thus, an end turn bundle that includes two interleaved groups of end turns may consume less axial space in the electric machine, may allow less axial distance between rotor bearing journals, and/or may reduce wear and/or damage to parts of the electric machine. In some cases, an end turn bundle that includes two interleaved groups of end turns may consume approximately half of the axial space that the end turn bundle would consume in other configurations.

[0200] FIG. 4H is a partial schematic side view of the example stator **450**. FIG. 4I is a partial schematic side view of a portion of the core **454** and example end turns **452a**, **452b** of a stator **450**. FIG. 4J is a schematic cross-sectional view from near the axial center of the example stator **450** toward the axial end of the example stator **450**. FIG. 4K is a partial schematic view of end turns **452a** and **452b** of a stator **450**.

[0201] FIG. 4L is a schematic of an example end turn **460** and an example end turn **4200**. The example end turn **460** can be included in the stator **108** of electric machine **102**. The example end turn **460** can be included in a lap winding configuration that includes two interleaved sets of end turns that form an end turn bundle having four radial layers. The example end turn **4200** is designed for a traditional lap winding configuration that does not include interleaved sets of end turns. In their respective configurations in stators of substantially equal radial dimension, the example end turns **460** and **4200** can span the same azimuthal angle. FIG. 4L includes example dimensions of the end turns **460** and **4200**. In some cases, an end turn has different dimensions.

[0202] FIG. 4M is a schematic perspective view of example end turns **460** and a portion of a stator core **462**. The radial dimension of the stator is mapped to a linear dimension in FIG. 4M for purposes of illustration. The end turns **460** represent the end turns **452** in a rectilinear coordinate system. The core **462** represents the core **454** in a rectilinear coordinate system. The end turns **460** include two groups of end turns that form four interleaved radial layers of end turns represented in a rectilinear coordinate system. A first group of end turns, that includes end turn **460a**, includes multiple end

turns at the same radial position as end turn **460a** and circumferentially offset from end turn **460a**. A second group of end turns, that includes end turn **460b**, includes multiple end turns at the same radial position as end turn **460b** and circumferentially offset from end turn **460b**.

[0203] FIG. 4N is a schematic perspective view of the portion of the example stator core **462** and the example end turns **460a** and **460b** represented in a rectilinear coordinate system. As illustrated in FIG. 4N, the ends of the end turns **460** and the core **462** define gaps **466** in the slots of the stator core. Each slot includes two gaps. One gap is between the ends of two different end turns. A gap **466a** is formed in a first slot at a first radius between the stator core and the end of an end turn residing in the first slot; a gap **466b** is formed in a second slot at a second radius between the ends of two end turns residing in the second slot; a gap **466c** is formed in the first slot at a third radius between the ends of two end turns residing in the first slot; and a gap **466d** is formed in the second slot at a fourth radius beyond the end of an end turn residing in the second slot. In some cases, coolant fluid (e.g., air, nitrogen, or another gas) can flow through the gaps **466** in the slots to cool the conductive windings. For example, the gaps **466** can extend axially between the axial ends of the stator and provide a coolant flow path along all or part of the axial length of the stator. Coolant fluid can flow between the axial sections of the conductive windings in the stator core (e.g., in gaps **466b** and **466c**). Coolant fluid can flow between an axial section of the conductive windings and the stator core (e.g., in gap **466a**). Coolant fluid can flow between an axial section of the conductive windings and the rotor (e.g., in gap **466d**). The coolant can flow from a mid-stack inlet to a volume surrounding the end turns to cool the end turns and the axial sections of the windings. The coolant can flow to a mid-stack outlet from a volume surrounding the end turns to cool the end turns and the axial sections of the windings. Coolant can additionally or alternatively flow in an gap between the rotor and the stator.

[0204] In some cases, the slots have alternating depths. For example, some of the slots in the core **462** may have a shallow slot depth, eliminating or reducing the volume of the gap **466a**. This may enhance magnetic flux properties of the stator.

[0205] FIG. 4O is a schematic perspective view of example end turns represented in a rectilinear coordinate system. Only two end turns **460a** and **460b** are shown in FIG. 4O for clarity of illustration.

[0206] An end turn bundle that includes two groups of end turns interleaved to form four layers of end turns can include formed windings, cable windings, or a combination thereof. FIGS. 4F, 4G, 4H, 4I, 4J, 4K, 4L, 4M, 4N, and 4O illustrate aspects of an example of a formed end turn bundle that includes two groups of formed end turns interleaved to form four layers of formed end turns. Each of the illustrated end turns of FIGS. 4F, 4G, 4H, 4I, 4J, 4K, 4L, 4M, 4N, and 4O can be built using standard end turn-forming equipment. However, some un-illustrated implementations may require non-standard end-turn-forming processes. FIGS. 4P, and 4Q illustrate an example of a cable end turn bundle that includes two groups of cable end turns interleaved to form four layers of cable end turns.

[0207] FIG. 4P is a schematic side view of an example end turn bundle **470** of a stator of an electric machine. The example end turn bundle **470** can be included in the stator **108** of electric machine **102**. FIG. 4Q is a schematic perspective view of the example end turn bundle **470**. FIG. 4EE is a

schematic end view of the example end turn bundle **470**. FIG. 4FF is a schematic end view of two end turns of the example end turn bundle **470**. FIG. 4GG is a schematic end view of four end turns of the example end turn bundle **470**. FIG. 4HH is a schematic side view of two end turns of the example end turn bundle **470**. FIG. 4II is a schematic cross-sectional view of the end turn bundle **470**, viewed from near the axial center of an example stator toward the axial end of the example stator.

[0208] The illustrated example end turn bundle **470** includes cable windings. The coils of the cable windings include axial sections (not illustrated in FIGS. 4P, 4Q, 4EE, 4FF, 4GG, 4HH, and 4II) that extend the axial length of a stator core. The coils of the cable windings include a plurality of end turns that form the end turn bundle **470** beyond the axial end of the stator core. The end turn bundle **470** includes two groups of end turns that form four interleaved radial layers of end turns. The first group of end turns includes end turns **4001a**, **4001c**, and **4001e**. The second group of end turns includes end turns **4001b** and **4001d**. Each group forms two of the four layers. The first group forms a first (outermost) layer of end turns and a third layer of end turns. The second group forms a fourth (innermost) layer of end turns and a second layer of end turns. One layer in each group is radially between the two layers of the other group. In particular, the second layer is radially between the first and third layers, and the third layer is radially between the second and fourth layers.

[0209] As shown in FIGS. 4FF, 4GG, and 4II, the two groups of end turns in the example end turn bundle **470** form only two radial layers at an axial section of the end turn bundle closest to the stator. In particular, all of the end turns in the end turn bundle **470** exit the end face of the core at a first radius on the end face and reenter the core at a second radius on the end face. The first group of end turns (including **4001a**, **4001c**, and **4001e**) exit the core through the end face of the core at an exit location on the first radius, turn toward the first radial layer, extend through the first radial layer, turn toward the third radial layer, extend through the third radial layer, and reenter the core through the end face at a reentry location on the second radius. In the example shown, before reentering the core, the first group end turns each curve radially inward from the third layer toward the second radius.

[0210] The second group of end turns (including **4001b** and **4001d**) exit the core through the end face at an exit location on the first radius, turn toward the second radial layer, extend through the second radial layer, turn toward the fourth radial layer, extend through the fourth radial layer, and reenter the core through the end face at a reentry location on the second radius. In the example shown, each end turn in the second group accommodates a neighboring coil in the first group. For example, as shown in FIG. 4GG, the end turn **4001d** exits the end face on the first radius, turns radially outward, extends through the second layer of end turns, turn radially inward, extends through the fourth layer of end turns, turn radially inward to accommodate the end turn **4001e**, and then turns radially outward to reenter the end face on the second radius.

[0211] FIGS. 4R and 4S show partial schematic end views of example cores **400** of a stator for an electric machine. The example cores **400** can be the core of the stator **108** of electric machine **102**. The example cores **400** include slots **404** having different shapes according to some implementations of the electric machine. Although the slots **404** are shown as including an even number of coils **414**, an odd number of coils **414**

may be used. In some implementations, the shape of the slots **404** may carry a winding that includes coils in a lap winding configuration and coil in a concentric winding configuration, although the slots shapes may be used in other types of windings.

[0212] As shown in FIG. 4R, each slot **404** includes a first slot region **421** holding coils **414** and a second slot region **419** holding coils **414**. The first slot region **421** is defined by two non-parallel opposing slot side portions **415c** and **415d**. The second slot region **419** is defined by two parallel opposing slot side portions **415a** and **415b**. The slot side portions **415a** and **415c** form part of one side of the slot. The slot side portions **415b** and **415d** form part of another side of the slot. The slot side portions **415a** and **415c** define a first angle at **417a**, and the slot side portions **415b** and **415d** define a second angle at **417b**. The first angle and the second angle are different angles, as shown in FIG. 4R. For example, the first angle at **417a** is an obtuse angle less than 180 degrees, and the second angle at **417b** is 180 degrees. Other angles may also be used.

[0213] FIG. 4T shows a partial schematic end view of an example core **400** of a stator for an electric machine in which the slots **404** include an odd number of coils **414**. In the example shown, the coils **414** include coils **414A**, **414B**, and **414C**. Although the coils **414A** and **414B** are shown as including an even number of coils, the coils **414A** and **414B** may include an odd number of coils. Further, the coils **414A** may be a left-hand coil side of lap coils, and the coils **414B** may be a right-hand coil side of lap windings. The coils **414C** are the coils of concentric windings. Thus, by including the coils **414C** in each slot **404**, the number of total coils **414** contained in each slot **404** is made an odd number. By having an odd number of coils in each slot, the voltage of the associated electric machine may be changed at smaller incremental levels, providing better control of the electric machine output.

[0214] FIG. 4U shows another core **400** in which the coils **414** may be different sizes to provide better nesting or packing of the coils **414** within the slots **404**. The coils **414A** and the coils **414B** may be of one size wire or cable, while the coils **414C** may be at a different size, such as a smaller size. The different size coils provide for a more closely packed slot **404**. Additionally, any of the coils **414A**, **414B**, or **414C** may be produced by a single turn winding process but multiple cables may be wound in parallel. Further, a generally triangular or trapezoidal cross-section wedge **1000** may be included in one or more of the slots **404** to maintain the coils **414A** and/or **414B** in a packed state. Over time and operation of the electric machine, the coils may relax in the slots, which may have an adverse effect on machine performance. For example, if the coils become loose inside the slot, the coils may sag and/or shift in the slot. As a result, the coils may be subject to damage due to vibration and/or chafing. Accordingly, the wedges **1000** are included in the slot to maintain the coils **414A** and/or **414B** in a packed condition. According to some implementations, the wedges **1000** may apply a biasing force on the coils to maintain the coils in a packed state. For example, the wedge **1000** may have a longitudinal curvature, as shown in FIG. 4V. In some implementations, the wedge **1000** becomes stressed when the wedge **1000** is inserted in a slot, and the stress results in the biasing force exerted on the coils in the slot. The biasing force applied by the wedge **1000** may hold the coils in a substantially fixed position, which may eliminate or reduce slack and/or sagging in the coils. For

example, the wedge **1000** in the slot may hold the coils in place and prevent damage that could be caused by loose, sagging, and/or shifted coils.

[0215] In FIG. 4V, the example wedge **1000** is illustrated as having a C-cross-section. The wedge **1000** may be positioned in the slots **404** as shown in FIGS. 4U and 4Z with the open portion of the C-cross-section facing the radial center of the core **400**. Alternately, the wedge **1000** may be inserted into the slots **404** so that the open portion of C-cross section faces away from the radial center of the core **400**. The wedges may have other shapes. Planar strips **1002** may also be used.

[0216] In some implementations, for example when the wedge **1000** is positioned as shown in FIGS. 4U and 4Z with the open end of the wedge **1000** facing the center of the core **400**, the cooling properties of the machine may be enhanced. Friction between the rotor and fluid surrounding the rotor (e.g., fluid in the machine gap between the rotor and the stator) can generate heat. To prevent overheating, cooling fluid (e.g. air or another type of fluid) may be directed through the machine gap between the rotor and the stator. The wedge **1000** can be configured to effectively increase the volume of the machine gap, as illustrated in FIGS. 4U and 4Z. For example, the wedge **1000** open to the center of the core **400** and the planar strip **1002** effectively lead to an increase in the volume of the machine gap. The increased volume in the machine gap may reduce demands on the machine's cooling system. For example, the increased volume may reduce the pressure drop along the machine gap, which may thus reduce the demands placed on the blower or pump that generates the flow of cooling fluid through the machine gap.

[0217] FIGS. 4AA-4DD show other example configurations of coils **414** and wedges **1000** in a stator **400** of an electric machine. FIG. 4AA shows a stator **400** that includes a first plurality of coils **414A** in a lap winding configuration and a second plurality of coils **414B** in concentric winding configuration. (The coils **414A** in a lap winding configuration are unshaded in FIGS. 4AA-4DD, and the coils **414B** in a concentric winding configuration are shaded in FIGS. 4AA-4DD.) The slots **404** of FIG. 4AA each have the same shape and carry the same number of conductors. In FIG. 4AA, each slot carries a concentric coil **414B** having one turn, and each slot carries a wedge **1000**. The concentric coils **414B** shown in FIG. 4AA can be wired in a "1-1-1" concentric coil configuration of a two pole, three phase electric machine. The "1-1-1" concentric coil configuration is discussed further with respect to FIG. 4W.

[0218] FIG. 4BB shows a stator **400** that includes a first plurality of coils **414A** in a lap winding configuration and a second plurality of coils **414B** in a concentric winding configuration. The stator **400** of FIG. 4BB includes slots having different shapes. For example, the slots **404C** and **404D** have the same shape and each carry ten conductors, but the slot **404E** has a different shape than the slots **404C** and **404D** and carries nine conductors. In FIG. 4BB, slots **404C** and **404D** each carry a concentric coil **414B** having two turns, while slot **404E** carries a concentric coil **414B** having one turn. Also in FIG. 4BB, each of the slots includes a wedge **1000**. The concentric coils **414B** shown in FIG. 4AA can be wired in a "2-2-1" concentric coil configuration of a two pole, three phase electric machine.

[0219] FIG. 4CC shows a stator **400** that includes a first plurality of coils **414A** in a lap winding configuration and a second plurality of coils **414B** in a concentric winding configuration. The stator **400** of FIG. 4CC includes slots having

different shapes. For example, the slots **404C** and **404E** have the same shape and each carry nine conductors, but the slot **404D** has a different shape than the slots **404C** and **404E** and carries ten conductors. In FIG. 4CC, slots **404C** and **404E** each carry a concentric coil **414B** having one turn, while slot **404D** carries a concentric coil **414B** having two turns. Also in FIG. 4CC, each of the slots includes a wedge **1000**. The concentric coils **414B** shown in FIG. 4CC can be wired in a “2-1-2/1-2-1” concentric coil configuration of a two pole, three phase electric machine.

[0220] FIG. 4DD shows a stator **400** that includes a first plurality of coils **414A** in a lap winding configuration and a second plurality of coils **414B** in a concentric winding configuration. The stator **400** of FIG. 4DD includes slots that all have the same shape, but do not all carry the same number of conductors. For example, the slots **404C** and **404D** each carry ten conductors, but the slot **404E** carries nine conductors. In FIG. 4DD, slots **404C** and **404D** each carry a concentric coil **414B** having two turns, while slot **404E** carries a concentric coil **414B** having one turn. Also in FIG. 4DD, each of the slots includes either a first wedge **1000A** or a second wedge **1000B**. The first wedge **1000A** in the slots **414C** and **414D** is smaller to leave more space for the conductors in the slots **414C** and **414D**. The second wedge **1000B** in the slot **414E** is larger and leaves less space for the conductors in the slot **414E**. The concentric coils **414B** shown in FIG. 4DD can be wired in a “2-2-1” concentric coil configuration of a two pole, three phase electric machine.

[0221] FIG. 4JJ is a schematic cross-sectional view of an example core **400** for an electric machine. The core **400** defines multiple slots, and each slot carries conductive coils **414** and a wedge. Two different types of wedges are shown in FIG. 4JJ. A first type of wedge **1004** has a C-shaped cross-sectional profile. FIG. 4MM shows a perspective view of the example wedge **1004**. A second type of wedge **1006** has an E-shaped cross-sectional profile. FIG. 4LL shows a perspective view of the example wedge **1006**. Both of the wedges **1004** and **1006** define holes **1008** that allow fluid to flow radially from a first region of the slot to a second region of the slot. For example, in the slots that carry a C-shaped wedge **1004**, the wedge **1004** defines a first region **1005** in the slot, and the coils **414** reside in a second region in the slot. The first region **1005** allows an axial flow of cooling fluid through the slot. The holes **1008** defined in the wedge **1004** allow fluid to flow from the first region **1005** to the second region in order to cool the coils **414**. The holes **1008** also allow fluid to flow from the second region into the first region **1005**, for example, after the fluid has contacted the coils **414**. As another example, in the slots that carry an E-shaped wedge **1006**, the wedge **1006** defines a first region **1009** in the slot, and the coils **414** reside in a second region in the slot. The first region **1009** allows axial flow of cooling fluid through the slot. The holes **1007** defined in the wedge **1006** allow fluid to flow from the first region **1009** to the second region in order to cool the coils **414**. The holes **1007** also allow fluid to flow from the second region into the first region **1005**, for example, after the fluid has contacted the coils **414**.

[0222] Each wedge may define multiple holes along the axial length of the wedge, as shown in FIGS. 4LL and 4MM. The holes may be spaced at regular intervals, random intervals, or in another manner. A single wedge **1006** or **1004** may define holes of different sizes, shapes, or dimensions in order to control fluid flow to the coils **414**. For example, larger holes may be defined in some locations on a wedge **1006** in order to

promote a greater flow rate through the larger holes, and smaller holes may be defined in other locations on the wedge **1006** in order to limit a flow rate through the smaller holes. The size, shape, spacing, and other parameters of the holes in a wedge may be configured to improve cooling in a stator of an electrical machine and thereby improve efficiency of the electrical machine. Thus, in some cases, a wedge can be used as a flow control device within the stator. In FIGS. 4LL and 4MM, a single hole is defined at each of multiple locations along the axial length of the wedge. In some implementations, there may be multiple holes defined at each location along the axial length.

[0223] The wedges **1004** and **1006** may have a longitudinal curvature, as the wedge **1000** shown in FIG. 4V. As a result of the longitudinal curvature, the wedges **1004** and **1006** may exert a biasing force on the coils **414** that helps stabilize the coils **414** within a slot. For example, the biasing force exerted by a wedge may prevent sagging of the coils **414**.

[0224] As seen in FIG. 4PP the wedges can be formed in two or more parts, such as a first part **1028** and a second part **1032**, longitudinally separated by a shim or stack of shims **1030**. When installed in the slot, the first part **1028** would reside adjacent the open end of the slot and the second part **1032** would reside adjacent the coils. Different thicknesses of the shim or shim stack **1030** can be selected to control the force exerted by the second part **1032** on the coils. For example, the first and second parts **1028**, **1032** can be installed into a given slot, and one or more shims **1032**, of the same and/or different thickness, added to increase the force exerted by the second part **1032** on the coils. In certain instances, different slots of the same electric machine may require different shims to achieve the same force exerted on the coils. The shim or shim stack **1030** can be installed after one or more of the first part **1028** or second part **1032** is installed in the slot to facilitate achieving the desired force without damaging the insulation or coating of the coils. Alternatively, the shim or shim stack **1030** can be installed substantially simultaneously with installing the first and second parts **1028**, **1032**. The shims **1032** thus allow for an adjustable tight fit between the wedge, the coils and the slot without damaging the cables during wedge insertion. Although shown as solid, the first and/or second parts **1028**, **1032** can each have a C-shaped cross-section or other cross-section providing an axial channel for fluid flow and holes for radial flow, as described above.

[0225] FIG. 4KK is a schematic cross-sectional view of an example core **400** for an electric machine. The core **400** in FIG. 4KK defines multiple slots, and each slot carries coils **414** and a wedge **1010**. The C-shaped wedges **1010** each define holes **1012** that allow fluid to flow radially between regions of the slot.

[0226] FIG. 4NN is an is a schematic end view of an example core **400** having wedges **1014** similar to any of the configurations described above, and/or of another configuration, retained using retaining rings **1016**. The wedge retaining rings **1016** encircle the central opening in the stator core **400** and are fixed (e.g., by bolt, screw and/or otherwise) to the end face of the core **400**. Retaining rings **1016** can be provided at both ends of the stator core **400** to capture the wedges **1014** and prevent the wedges **1014** from moving axially along the stator core **400**. The retaining rings **1016** have slots that receive and interlock with protrusions **1020** at the ends of each wedge **1014**, preventing the wedges **1014** from moving radially. The retaining ring **1016** also press the wedges **1014**

against the top of the stator slot. In instances, such as FIG. 4PP, where the wedges are formed in multiple parts and/or include one or more shims, the retaining ring 1016 can also retain the multiple wedge parts and shims. FIG. 4OO is a perspective view of an example C-shaped wedge 1014 better illustrating the protrusion 1020 and also having holes 1026. The C-shaped defines an axial passage 1024 through the wedge 1014. As seen in FIG. 4NN, the retaining rings 1016 can have apertures 1022 that align with the axial passage 1024 to allow flow of fluids through the retaining rings 1016.

[0227] FIG. 4QQ shows an slot liner 1034 for lining the interior of a stator slot in a stator core 400 of an electric machine. The slot liner 1034 is made of a flexible, tear and temperature resistant film, such as polyester, polyamide and/or other material. FIG. 4QQ shows the liner 1034 laid flat. When installed in a slot, as in FIG. 4RR, the liner 1034 extends from the slot at both ends of stator core 400, and can be folded onto the end faces of the stator core 400. The protruding ends of liner 1034 are clamped to the end faces of the stator core 400 with a retaining ring (as in FIG. NN) and/or with other clamps to retain the liner 1034 in position. FIG. 4RR shows single bar clamps 1036a, retained to the end face with fasteners 1038 (e.g., bolt, screw and/or other fastener), that clamp a portion of two adjacent liners to the end of the stator core 400. FIG. 4SS shows U-shaped clamps 1036b, likewise retained to the end face with fasteners 1038. The clamps can be retained to the stator core 400 in other manners. The slot liners 1038 are installed prior to winding the coils into the slots to protect cables and the insulation on the cables during winding. In certain instances, the liners 1034 can be removed from the slots. In certain instances, the liners 1034 can remain in the slots while the remainder of the electric machine is assembled, and remain in the slots during operation of the electric machine. Because the slot liners 1034 are retained against the end faces of the stator core 400 the liners resist shifting during winding and subsequent operation of the machine, and prevent the cables from rubbing against the stator core. In instances where the liners 1034 will be removed, a multipart wedge and shim(s) (as in FIG. 4PP) can be used such that with the shim not installed, the coils are loose in the slot and the liner 1034 can more easily withdrawn from the slot. Thereafter, the shim would be installed to secure the coils in the slots.

[0228] FIG. 4W shows a windings schematic according to some implementations. The windings scheme shown in FIG. 4W utilizes both concentric coils and lap coils in a single stator. The schematic illustrates windings of a two pole, three phase electric machine. The letter group A, A', a, and a' represent the first phase winding. The letter group B, B', b, and b' represent the second phase winding. The letter group C, C', c, and c' represent the third phase winding. The three coils represented by A and A' are the lapped portion of the first phase winding. The three coils a and a' represent the concentric portion of the first phase winding. The solid and dashed lines represent the end turn connections for the first phase winding. Each line may represent a single or multiple turns. The end turn connections for the second and third phase are not shown, but the same connection configuration for the first phase may also be used for the second and third phases.

[0229] FIG. 4W shows an example of a "1-1-1" concentric coil configuration. In the "1-1-1" concentric coil configuration shown, each of the three coils of the concentric portion of the first phase winding includes a single turn. As such, each slot of the stator in the "1-1-1" concentric coil configuration

carries the same number of turns, namely one turn each. The concentric coils 414B shown in FIG. 4AA are in a "1-1-1" concentric coil configuration. More generally, an "n-n-n" concentric coil configuration carries "n" concentric coil turns in each slot. Example values of "n" can include 1, 2, 3, . . . 10, and higher values. Other types of concentric coil configurations are also possible. Other example concentric coil configurations include a "2n-n-2n/n-2n-n" concentric coil configuration (e.g., the "2-1-2/1-2-1" concentric coil configuration shown in FIG. 4CC, or another), a "2n-2n-n" concentric coil configuration (e.g., the "2-2-1" concentric coil configuration shown in FIG. 4DD, or another), and/or others. Example values of "n" can include 1, 2, 3, . . . 10, and higher values.

[0230] Two other example concentric coil configurations are shown in FIGS. 4X and 4Y. FIG. 4X shows an example of a "2-1-1" concentric coil configuration. In the "2-1-1" concentric coil configuration shown, the outermost coil of the concentric portion of the first phase winding includes a two turns, and each of the two inner coils of the concentric portion of the first phase winding include a single turn. As such, different slots of the stator in the "2-1-1" concentric coil configuration carry different numbers of turns. In particular, a first slot carries two turns of the concentric portion of the first phase winding, and a second and a third slot each carry only one turn of the concentric portion of the first phase winding. Other types of "2n-n-n" concentric coil configurations may also be used. Example values of "n" can include 1, 2, 3, 10, and higher values.

[0231] FIG. 4Y shows an example of a "2-1-0" concentric coil configuration. In the "2-1-0" concentric coil configuration shown, the concentric coil configuration includes two concentric coils for each phase winding and three lap coils for each phase winding. The outer concentric coil includes a two turns, and the inner concentric coil includes one turn. As such, different slots of the stator in the "2-1-0" concentric coil configuration carry different numbers of turns. In particular, a first slot carries two turns of the concentric portion of the first phase winding, a second slot carries one turn of the concentric portion of the first phase winding, and a third slot carries no concentric coil turns. Other types of "2n-n-0" concentric coil configurations may also be used. Example values of "n" can include 1, 2, 3, . . . 10, and higher values.

[0232] FIGS. 4TT, 4UU, 4VV, 4WW, and 4XX show a solid model of an example stator 4100 of an electric machine that includes the windings represented in the diagram of FIG. 4W. The example stator 4100 can be used for the stator 108 of electric machine 102. FIGS. 4TT and 4VV are perspective views of a first end of the example stator 4100. FIG. 4UU is an end view of the example stator 4100, viewed from the first end of the stator. FIG. 4WW is a side view of a second end of the example stator 4100. FIG. 4XX is a perspective view of the second end of the example stator 4100. As shown in FIGS. 4TT, 4UU, 4VV, 4WW, and 4XX, the example stator includes an elongate stator core 4102 and three conductive windings carried by the core 4102. A first winding includes concentric-wound coils 4104a and lap-wound coils 4106a. A second winding includes concentric-wound coils 4104b and lap-wound coils 4106b. A third winding includes concentric-wound coils 4104c and lap-wound coils 4106c. The letter labels A, A', B, B', C, and C' for the lap-wound coils and the letter labels a, a', b, b', c, and c' for the concentric-wound coils are included to show correspondence with FIG. 4W. While the end turns of the coils are primarily visible in FIGS. 4TT,

4UU, 4VV, 4WW, and 4XX, the coils also include axial portions that extend between the end turns within the stator core 4102. As shown in FIG. 4UU, the elongate core 4102 is adapted to internally receive a rotor of an electric machine.

[0233] The coils in each winding are connected in series. Each coil may include multiple turns connected in series or in parallel. Each slot can carry an odd number of turns or an even number of turns. In some implementations, the slots in the stator 4102 do not all carry the same number of turns. In some implementations, the concentric-wound coils in a winding all have a first number of turns, and the lap-wound coils in the same winding all have a second number of turns, unequal to the first number of turns. Installing one or more of the coils may include forming a winding structure outside of the core 4102 and installing the formed winding structure in the core 4102. Installing one or more of the coils may include successively forming each of the individual coils in the core 4102.

[0234] The core 1402 includes a first end face 4108a shown in FIGS. 4TT and 4VV. The core 1402 includes a second, opposing end face 4108b shown in FIGS. 4WW and 4XX. The coils 4104a, 4104b, 4104c, 4106a, 4106b, and 4108c each define a loop that extends axially through the elongate core 4102, exits the core 4102 through the end face 4108a at an exit location, and reenters the core through the end face 4108a at a reentry location. Each of the coils spans a distance on the end face between its exit location and its reentry location.

[0235] The lap-wound coils 4106a in the first winding each span a distance that is substantially equal to the distance spanned by each of the other lap-wound coils 4106a in the first winding, while the concentric-wound coils 4104a in the first winding each span a distance that is unequal to a distance spanned by any of the other concentric-wound coils 4104a in the first winding. Similarly, the lap-wound coils 4106b in the second winding each span a distance that is substantially equal to the distance spanned by each of the other lap-wound coils 4104b in the second winding, the concentric-wound coils 4104b in the second winding each span a distance that is unequal to the distance spanned by any of the other concentric-wound coils 4104b in the second winding, the lap-wound coils 4106c in the third winding each span a distance that is substantially equal to the distance spanned by each of the other lap-wound coils 4106c in the third winding, and the concentric-wound coils 4104c in the third winding each span a distance that is unequal to the distance spanned by any of the other concentric-wound coils 4104c in the third winding.

[0236] The distance on the end face spanned each coil can be an angular distance on the end face between the exit location of the coil and the reentry location of the coil. For example, when the end face of the core defines a circumference, the distance on the end face spanned by a coil can be an angle between the exit location of the coil and the reentry location of the coil with respect to the center point of the circumference. In the example, each coil defines a mid-point on the circumference between its exit location and its reentry location. For the concentric-wound coils 4104a, 4104b, and 4104c, the mid-point of each coil is substantially at the same angle on the circumference as the mid-point of each other concentric-wound coil in the same winding. For the lap-wound coils 4106a, 4106b, and 4106c, the mid-point of each coil is at a different angle on the circumference than the mid-point of any other lap-wound coil in the same winding.

[0237] The core 4102 includes teeth that extend radially toward an axial center of the core 4102. The teeth define radial

slots between the teeth, and the coils are carried in the slots. Thus, the core defines an array of slots to carry the windings. Each coil resides in a pair of non-adjacent slots, and thus, each coil spans a number of slots between the non-adjacent slots in which the coil resides. Each of the lap-wound coils 4106a in the first winding spans a number of slots that is equal to the number of slots spanned by each of the other lap-wound coils 4106a in the first winding, while each of the concentric-wound coils 4104a in the first winding spans a number of slots that is unequal to the number of slots spanned by any of the other concentric-wound coils 4104a in the first winding. For example, each of the lap-wound coils 4106a spans eight slots, while the three concentric-wound coils 4104a span 6, 8, and 10 slots, respectively. Similarly, each of the lap-wound coils 4106b in the second winding spans a number of slots that is equal to the number of slots spanned by each of the other lap-wound coils 4106b in the second winding, each of the concentric-wound coils 4104b in the second winding spans a number of slots that is unequal to the number of slots spanned by any of the other concentric-wound coils 4104b in the second winding, each of the lap-wound coils 4106c in the third winding spans a number of slots that is equal to the number of slots spanned by each of the other lap-wound coils 4106c in the third winding, and each of the concentric-wound coils 4104c in the third winding spans a number of slots that is unequal to the number of slots spanned by any of the other concentric-wound coils 4104c in the third winding.

[0238] A number of implementations have been described. Nevertheless, it will be understood that various modifications may be made. Accordingly, other implementations are within the scope of the following claims.

What is claimed is:

1. A stator for an electric machine, the stator comprising:
 - a. an elongate core having an end face and an opposing end face, the elongate core adapted to internally receive a rotor of an electric machine;
 - b. a plurality of conductive coils, each coil defining a loop that extends axially through the elongate core, exits the core through the end face, and reenters the core through the end face, a first subset of the coils collectively forming a first radial layer axially exterior the core and a third radial layer axially exterior the core, each coil in the first subset residing in both the first layer and the third layer, a second subset of the coils collectively forming a second radial layer axially exterior the core and a fourth radial layer axially exterior the core, each coil in the second subset residing in both the second layer and the fourth layer, the second layer residing radially between the first and third layers, the third layer residing radially between the second and fourth layers.
2. The stator of claim 1, wherein the loop defined by each coil in the first subset exits the core through the end face at an exit location in the first radial layer and reenters the core through the end face at a reentry location in the third radial layer, and wherein the loop defined by each coil in the second subset exits the core through the end face at an exit location in the second radial layer, and reenters the core through the end face at a reentry location in the fourth radial layer.
3. The stator of claim 1, wherein the plurality of coils forms two radial layers in the elongate core, and each of the coils resides in both radial layers in the elongate core.
4. The stator of claim 3, wherein the two radial layers in the elongate core define two radii on the end face including a first radius and a second radius, the loop defined by each coil in the

first subset exits the core through the end face at an exit location on the first radius, turns toward the first radial layer, extends through the first radial layer, turns toward the third radial layer, extends through the third radial layer, and reenters the core through the end face at a reentry location on the second radius.

5. The stator of claim 4, wherein the loop defined by each coil in the second subset exits the core through the end face at an exit location on the first radius, turns toward the second radial layer, extends through the second radial layer, turns toward the fourth radial layer, extends through the fourth radial layer, and reenters the core through the end face at a reentry location on the second radius.

6. The stator of claim 1, wherein the core comprises a plurality of slots to carry the coils, a first subset of the slots each carry two of the first subset of coils, and a second subset of the slots each carry two of the second subset of coils.

7. The stator of claim 6, wherein a radial distance between two coils in each slot and an azimuthal distance between two sides of the slot define a gap in the slot.

8. The stator of claim 6, wherein first subset of slots and the second subset of slots all have substantially equal radial depths.

9. The stator of claim 6, wherein an inner-most radial layer comprises the fourth radial layer, an outer-most radial layer comprises the first radial layer, the first subset of slots have a first radial depth, the second subset of slots have a second radial depth, and the second radial depth is less than the first radial depth.

10. A stator for an electric machine, the stator comprising: an elongate core adapted to internally receive a rotor of an electric machine;

a first plurality of coils arranged in a first lap winding configuration and forming a first plurality of end turns that each extend through a first radial layer of end turns and a third radial layer of end turns; and

a second plurality of coils arranged in a second lap winding configuration and forming a second plurality of end turns that each extend through a second radial layer of end turns and a fourth radial layer of end turns, the second layer residing radially between the first and third layers, the third layer residing radially between the second and fourth radial layers.

11. The stator of claim 10, wherein the first plurality of coils and the second plurality of coils collectively form two radial layers in the core, wherein each of the first plurality of coils and each of the second plurality of coils resides in both of the two radial layers in the core.

12. The stator of claim 10, wherein the first plurality of coils collectively form four radial layers in the core, the first plurality of coils reside in a first pair of the four radial layers in the core, the second plurality of coils reside in a second pair of the four radial layers in the core.

13. The stator of claim 12, wherein the stator defines an array of slots, the first plurality of coils resides in a first subset of the slots, the second plurality of coils resides in a second subset of the slots.

14. The stator of claim 13, wherein two of the coils reside in each slot, and a radial spacing between the coils in each slot define a radial gap in the slot.

15. The stator of claim 13, wherein the first subset of slots have a first radial depth and the second subset of slots have a second radial depth that is less than the first radial depth.

16. A method of making a stator of an electric machine, the method comprising:

installing a first plurality of coils in a core of a stator, the first plurality of coils collectively forming a first radial layer of end turns and a third radial layer of end turns axially external the core, each of the first plurality of coils defining a loop that extends axially through the core, exits the core through the end face, extends through the first radial layer, extends through the third radial layer, and reenters the core through the end face; and

installing a second plurality of coils in the core of the stator, the second plurality of coils collectively forming a second radial layer of end turns and a fourth radial layer of end turns axially external the core, each of the second plurality of coils defining a loop that extends axially through the core, exits the core through the end face, extends through the second radial layer, extends through the fourth radial layer, and reenters the core through the end face;

wherein the second radial layer resides radially between the first and third radial layers, and the third layer resides radially between the second and fourth radial layers.

17. The method of claim 16, further comprising coupling the first plurality of coils to the second plurality of coils to form a three-phase conductive winding.

18. The method of claim 16, further comprising operating the electric machine as a multi-pole electric machine.

19. The method of claim 16, wherein installing at least one of the first plurality of coils or the second plurality of coils comprises forming a winding structure outside of the core and installing the formed winding structure in the core.

20. The method of claim 16, wherein installing at least one of the first plurality of coils or the second plurality of coils comprises installing each of the plurality of coils by successively forming individual turns of the coil in the core of the stator.

21. The method of claim 16, wherein installing the first plurality of coils and installing the second plurality of coils comprises simultaneously installing the first plurality of coils and the second plurality of coils.

* * * * *