

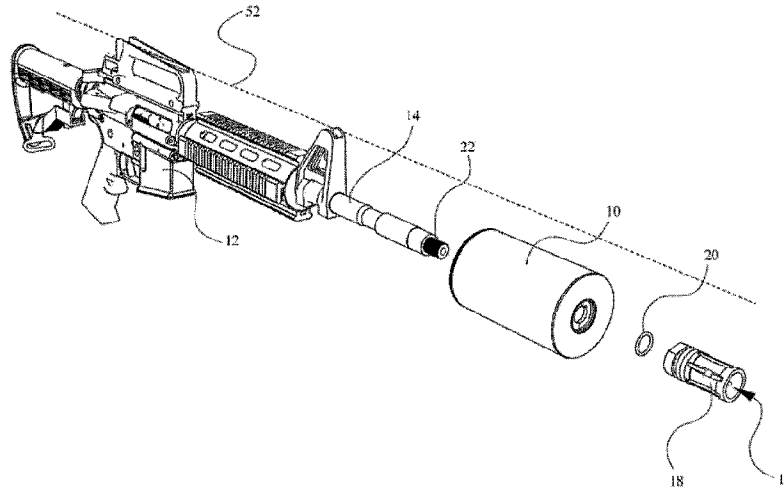

(86) **Date de dépôt PCT/PCT Filing Date:** 2014/01/10
 (87) **Date publication PCT/PCT Publication Date:** 2014/10/30
 (45) **Date de délivrance/Issue Date:** 2020/10/27
 (85) **Entrée phase nationale/National Entry:** 2015/07/07
 (86) **N° demande PCT/PCT Application No.:** US 2014/011062
 (87) **N° publication PCT/PCT Publication No.:** 2014/175932
 (30) **Priorité/Priority:** 2013/01/10 (US13/738,186)

(51) **Cl.Int./Int.Cl. F41G 3/12** (2006.01),
F41A 35/00 (2006.01)
 (72) **Inventeur/Inventor:**
HODGSON, DALE ALBERT, US
 (73) **Propriétaire/Owner:**
HODGSON, DALE ALBERT, US
 (74) **Agent:** PIASETZKI NENNIGER KVAS LLP

(54) **Titre : STABILISATEUR GYROSCOPIQUE D'ARME MOTORISEE**
 (54) **Title: MOTORIZED WEAPON GYROSCOPIC STABILIZER**



(57) **Abrégé/Abstract:**

A motorized weapon gyroscopic stabilizer which creates a stabilizing effect for single shot, semi-automatic, and fully automatic weapons. The rotating mass that generates the gyroscopic stabilizing effect is the rotor of the motor. The motor is designed to allow the mass to rotate around the open core of the motorized weapon gyroscopic stabilizer. Because of its open core design the motorized weapon gyroscopic stabilizer allows the fired projectile to pass through it, or be mounted in line with the sighting mechanism allowing the target alignment - line of sight to pass through the motorized weapon gyroscopic stabilizer, or both.

(12) INTERNATIONAL APPLICATION PUBLISHED UNDER THE PATENT COOPERATION TREATY (PCT)

(19) World Intellectual Property
Organization
International Bureau(10) International Publication Number
WO 2014/175932 A3(43) International Publication Date
30 October 2014 (30.10.2014)

(51) International Patent Classification:

F41G 7/20 (2006.01) *G02B 27/64* (2006.01)
F41G 7/26 (2006.01)

(21) International Application Number:

PCT/US2014/011062

(22) International Filing Date:

10 January 2014 (10.01.2014)

(25) Filing Language:

English

(26) Publication Language:

English

(30) Priority Data:

13/738,186 10 January 2013 (10.01.2013) US

(72) Inventor; and

(71) Applicant : **HODGSON, Dale, Albert** [US/US]; 13035
Vista Pointe, Chardon, OH 44024 (US).(74) Agent: **WEINMAN, Sean, M.**; Fay Sharpe LLP, The
Halle Building, 5th Floor, 1228 Euclid Avenue, Cleveland,
OH 44115-1843 (US).(81) Designated States (unless otherwise indicated, for every
kind of national protection available): AE, AG, AL, AM,
AO, AT, AU, AZ, BA, BB, BG, BH, BN, BR, BW, BY,
BZ, CA, CH, CL, CN, CO, CR, CU, CZ, DE, DK, DM,
DO, DZ, EC, EE, EG, ES, FI, GB, GD, GE, GH, GM, GT,

HN, HR, HU, ID, IL, IN, IR, IS, JP, KE, KG, KN, KP, KR,
KZ, LA, LC, LK, LR, LS, LT, LU, LY, MA, MD, ME,
MG, MK, MN, MW, MX, MY, MZ, NA, NG, NI, NO, NZ,
OM, PA, PE, PG, PH, PL, PT, QA, RO, RS, RU, RW, SA,
SC, SD, SE, SG, SK, SL, SM, ST, SV, SY, TH, TJ, TM,
TN, TR, TT, TZ, UA, UG, US, UZ, VC, VN, ZA, ZM,
ZW.

(84) Designated States (unless otherwise indicated, for every
kind of regional protection available): ARIPO (BW, GH,
GM, KE, LR, LS, MW, MZ, NA, RW, SD, SL, SZ, TZ,
UG, ZM, ZW), Eurasian (AM, AZ, BY, KG, KZ, RU, TJ,
TM), European (AL, AT, BE, BG, CH, CY, CZ, DE, DK,
EE, ES, FI, FR, GB, GR, HR, HU, IE, IS, IT, LT, LU, LV,
MC, MK, MT, NL, NO, PL, PT, RO, RS, SE, SI, SK, SM,
TR), OAPI (BF, BJ, CF, CG, CI, CM, GA, GN, GQ, GW,
KM, ML, MR, NE, SN, TD, TG).

Published:

- with international search report (Art. 21(3))
- before the expiration of the time limit for amending the
claims and to be republished in the event of receipt of
amendments (Rule 48.2(h))

(88) Date of publication of the international search report:
29 January 2015

(54) Title: MOTORIZED WEAPON GYROSCOPIC STABILIZER

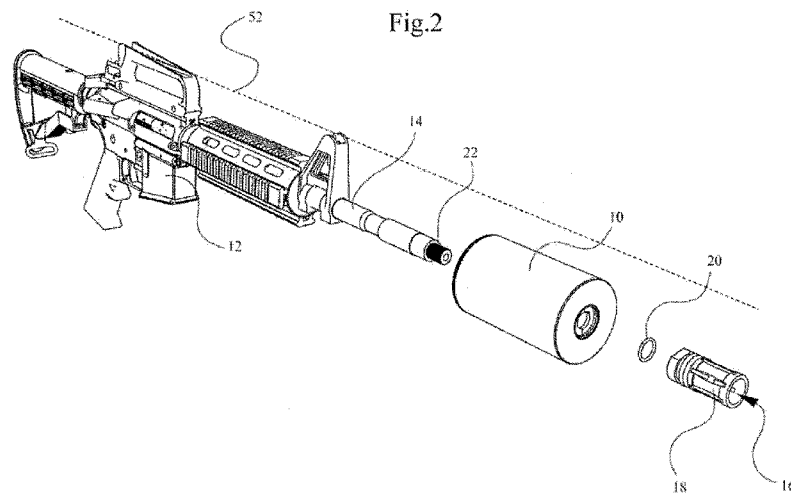

(57) Abstract: A motorized weapon gyroscopic stabilizer which creates a stabilizing effect for single shot, semi-automatic, and fully automatic weapons. The rotating mass that generates the gyroscopic stabilizing effect is the rotor of the motor. The motor is designed to allow the mass to rotate around the open core of the motorized weapon gyroscopic stabilizer. Because of its open core design the motorized weapon gyroscopic stabilizer allows the fired projectile to pass through it, or be mounted in line with the sighting mechanism allowing the target alignment - line of sight to pass through the motorized weapon gyroscopic stabilizer, or both.

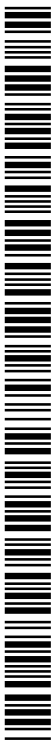

WO 2014/175932 A3

MOTORIZED WEAPON GYROSCOPIC STABILIZER

DESCRIPTION

The present application relates to weapon stabilizer systems. It finds particular application in utilizing a motorized weapon gyroscopic stabilizer to create a stabilizing effect for single shot, semi-automatic, and fully automatic weapons, and will be described with particular reference thereto. It is to be understood, however, that it also finds application in other devices, and is not necessarily limited to the aforementioned application.

Shooting a weapon depends on a high degree of precision. Slight movements made by the shooter significantly alter the accuracy of the shot. This variation in target alignment is made even more significant when compounded over long distances. Over time, shooters have been taught to minimize these movements by using a variety of methods to create stability and support of the weapon during target alignment and firing of the weapon. This desired stability of the target alignment is so critical that a shooter is taught to measure his breaths, and be aware of his heartbeats as he prepares for his shot. A small fraction of a degree in target misalignment when magnified over a long distance is enough to miss the target.

While there are a variety of sights, scopes, and aiming devices available for weapons, they only serve to make the shooter more aware of the existing deviations experienced during aiming and firing at his target. Typically, the shooter has the ability to support his weapon from the middle and/or rear with handgrips, and/or stock supports. When possible, a shooter enhances his stability by supporting the weapon with external stable surfaces available to him in his environment at the time. Unfortunately, due to the different conditions and environments in which a weapon is expected to function, the ideal support for the weapon is not always available. Without the aid of external stable surfaces for the weapon, the shooter is dependent on supporting the unsupported weapon with his skeletal structure incorporated into their position, and the steadiness of their muscles.

With a weapon, during the first shot, the shooter typically experiences recoil from the shot. During this recoil phase, the weapon typically moves as the projectile is fired and propelled and leaves the weapon. Typically, this recoil affects the least supported part of

the weapon the most. This recoil causes alignment with the target to be altered, and requires subsequent shots to be made after adjusting target alignment, causing a delay in repeated firing and the ability to aim accurately. The less the natural recoil of the weapon affects the target alignment, the faster the target can be reacquired, and subsequent shots may be made.

5 This recoil problem is present with single shot, semi-automatic, and fully automatic weapons.

Gyroscopes have been utilized in the past in a wide variety of stabilizing applications, but size, weight, and bulk have limited their application related to the handheld weapon field. Gyroscopes are heavy and cumbersome, and while used for applications such as on cameras, missiles, battleship guns, and tanks, they have never been practically used on
10 handheld weapons.

The present application provides a weapon stabilizer system and apparatus which overcomes the above-referenced problems and others.

In accordance with one aspect, a motorized weapon gyroscopic stabilizer
15 system is provided. The system includes a housing including an open core rigidly mounted to a barrel of a weapon. An electronic motor includes a rotor configured to provide gyroscopic stability, the rotor surrounding the open core and including an axis of rotation and a mass element configured to rotate around the axis of rotation.

The motorized weapon gyroscopic stabilizer improves the stability of a weapon
20 during single shots, semi-automatic shots, and fully automatic shots through the use of a lightweight high speed integral brushless motor driven gyroscopic stabilization device. The device relies on the three primary variables involved in creating gyroscopic stability; the mass of the spinning element, the speed of the spinning element, and the diameter of the spinning element. By altering any of these three variables, the gyroscopic stability is altered. However,
25 emphasis may be placed on any of these three variables to overcome the limitations applied to any of the other variables.

To accomplish gyroscopic stability, the motorized weapon gyroscopic stabilizer utilizes a relatively small diameter, low mass, high speed brushless motor driven gyroscope created with integral construction to the weapon, designed to spin on an axis parallel to the
30 weapons direction of fire and/or target alignment method/device. The motorized weapon

gyroscopic stabilizer also utilizes a method to increase the speed of the spinning mass to produce extremely high revolutions per minute allowing the device to lower the mass of the spinning mass element while achieving the same gyroscopic stability, thus making the device lighter.

5 The motorized weapon gyroscopic stabilizer is also designed to be quieter by eliminating traditional electric DC motor construction which requires an electric motor, drive trains and independent gyroscopic spinning mass elements, all of which produce noise. Instead, the device is designed to create its gyroscopic stability through the natural construction of a brushless motor and the spinning mass of its rotor. The brushless motor is
10 designed to spin on an axis parallel to the weapons direction of fire and/or target alignment method/device. Also, because the brushless motor does not utilize traditional electric motor brushes, it eliminates the noise created from the friction of brushes contacting the stator.

 The motorized weapon gyroscopic stabilizer is also designed to minimize bulk by integrating the gyroscope into the weapons natural structure emphasizing its attachment in
15 line with the axis parallel to the weapons direction of fire and/or target alignment method/device. The device has a small rotational mass diameter and compensates for this through its high speed rotation. The diameter of the spinning mass element is critical to the function of a gyroscope. Increasing the diameter, increases the gyroscopic stability it generates. The brushless motor eliminates the need to create a separate motor which would
20 require additional gears, pulleys, or drive train mechanisms required to transfer rotation to a gyros secondary diameter of mass, all of which adds to a devices bulk. The motorized gyroscopic weapon stabilizer is designed with a hollow rotational axis which allows it to share space with other functional elements incorporated into all weapons, such as, but not limited to; by way of example in a firearm type weapon; its barrel, its axis parallel to the weapons
25 direction of fire, and/or with the target alignment-line of sight method/device natural to the firearm.

 This sharing of space allows the motorized weapon gyroscopic stabilizer to incorporate with the natural form of the weapon, and prevent the bulk of adding a separate large cylindrical shape, which is essential to create a gyroscopic stabilizer, somewhere else on
30 a weapon. Due to this form, it allows the device to be positioned as far away as practical from

the already existing support surfaces on the weapon to maximize the gyroscopic stability it provides.

This motorized weapon gyroscopic stabilizer is designed to be either rigidly attached or be made removable from the weapon. The attachment method varies and is
5 dependent on the design and the configuration of the specific weapon, and may be attached either permanently, or temporarily. This is fully capable of being added to, or removed from the weapon, or in being permanently attached or permanently affixed into the weapons structure.

The motorized weapon gyroscopic stabilizer is designed to be either used
10 independently, or incorporated into other devices including but not limited to; barrels, flash suppressors, silencers, noise suppressors, scopes, lasers, optics, holographic sights, target alignment devices, and other devices benefiting from its unique hollow core construction.

Still further advantages of the present invention will be appreciated to those of ordinary skill in the art upon reading and understand the following detailed description.

15 The invention may take form in various components and arrangements of components, and in various steps and arrangements of steps. The drawings are only for purposes of illustrating the preferred embodiments and are not to be construed as limiting the invention.

20 FIGURE 1 is an illustration of the motorized weapon gyroscopic stabilizer mounted to a weapon, by way of example the barrel of a firearm.

FIGURE 2 is an illustration of the motorized weapon gyroscopic stabilizer mounted to a weapon through one of the many ways of attachment by way of example the barrel of a firearm.

25 FIGURE 3 is an illustration of an exploded view of the motorized weapon gyroscopic stabilizer.

FIGURE 4 is an illustration of the motorized weapon gyroscopic stabilizer attached in an alternate by way of example as an extension of the barrel of a firearm.

FIGURE 5 is an illustration of the motorized weapon gyroscopic stabilizer attached to the barrel of a pistol type firearm.

FIGURE 6 is an illustration of the motorized weapon gyroscopic stabilizer attached by way of example to the barrel of a rifle type weapon with the projectile passing through the motorized gyroscopic weapon stabilizer, and the target alignment – line of sight not passing through the motorized gyroscopic weapon stabilizer.

FIGURE 7 is an illustration of the motorized weapon gyroscopic stabilizer attached by way of example to a rifle type firearm allowing the target alignment – line of sight to pass through the open core of the motorized gyroscopic weapon stabilizer.

10

With reference to FIGURE 1, the motorized weapon gyroscopic stabilizer **10** is illustrated by way of example as being mounted onto the barrel **14** of a weapon **12**. Such type of weapon **12** include a single shot, semi-automatic, or fully automatic weapon **12** with either single or multiple barrels **14**. By way of example, the motorized weapon gyroscopic stabilizer **10** is rigidly attached to the barrel **14** of a rifle type weapon **12**. The barrel **14** passes through the motorized weapon gyroscopic stabilizer **10** and is secured by way of example by the attachment of a flash suppressor **18** or other retention method. This method of attachment is only one method of attaching the motorized weapon gyroscopic stabilizer **10** to a weapon **12**. Since weapon **12** configurations vary significantly, the attachment method varies according to the weapon **12**. The projectile exit **16** of the weapon **12** allows the projectile to pass through the motorized weapon gyroscopic stabilizer **10**. The motorized weapon gyroscopic stabilizer **10** is intended to work with single and multiple barrel weapons **12**. The motorized weapon gyroscopic stabilizer **10** provides stability to the weapon **12** by the extremely fast rotation of the cylinder of mass around the hollow core of the device. The center of rotation as shown by way of example is aligned with the barrel **14** of the weapon **12** so that the projectile passes through the motorized gyroscopic weapon stabilizer **10**. In other configurations, the motorized weapon gyroscopic stabilizer **10** allows the target alignment – line of sight **52** to pass through it, or function having both the target alignment – line of sight **52** and the axis of the projectile exit **16** aligned through the motorized gyroscopic weapon stabilizer **10** allowing the projectile to pass through it as well. The sighting mechanism **54** used on the weapon may vary

30

considerably, which include visual, non-magnified, magnified, optical or other types of sighting mechanisms **54** designed to create target alignment – line of sight **52** function through the open core of this device.

In FIGURE 2, the motorized weapon gyroscopic stabilizer **10** is mounted to a
5 weapon **12** in another example. As illustrated, the motorized weapon gyroscopic stabilizer **10** is shown by way of example on a rifle type weapon **12** being rigidly attached by using the threaded portion of the barrel **22** of the weapon **12** along with the threaded flash suppressor **18** normal to this type of weapon **12**. In other rifle or pistol type weapons **12**, the motorized
10 weapon gyroscopic stabilizer **10** is attached onto the barrel **14**, or in front of the barrel **14** with different brackets or attachment modifications making it; permanently incorporated into the barrel **14**, rigidly fixed to the barrel **14**, or temporarily fixed to the barrel **14** depending on the application. The motorized weapon gyroscopic stabilizer **10** is able to be mounted in similar ways to the weapon **12** with the target alignment – line of sight **52** passing through it.

FIGURE 3 illustrates the motorized weapon gyroscopic stabilizer **10** in an
15 exploded drawing. The inner housing **24** is designed to create the open core shaft of an brushless motor, allowing it to be mounted to a weapon **12** in variety of ways. The inner housing **24** is rigidly attached to the outer housing **36**, making water resistant assembly possible. By way of example, the inner housing **24** is shown as threaded, although there are many different methods to rigidly attach the inner housing **24** to the outer housing **36**. The
20 inner housing **24** may be constructed of a wide variety of different materials. The rear ring seal **40** attaches to the inner housing **24** to create the rear portion of the water resistant seal to the elements. An electronic power board houses electronics which powers and controls the motorized gyroscopic weapon stabilizer **10**. The electronic power board controls the operation of the brushless motor, and is programmed to provide speeds and start-stop settings for the
25 brushless motor function. The electronic power board can be rigidly attached to the inner housing **24** or located on different locations on the weapon **12**. The rear retainer **44** slides over the inner housing **24** and holds the elements in position inside the motorized gyroscopic weapon stabilizer **10**. The rear retainer **44** positively engages into a groove in the inner housing **24** for fixed positioning. The magnets **26** are bonded to the inside of the rotor **30**.
30 The magnets **26** count and spacing is varied according to the desired speed and torque of the

brushless motor. The stator and windings **42** are formed from stacks of electric steel with copper wire windings wound around their poles. The pattern of the stator and windings **42** are varied according to the desired speed and torque of the brushless motor. A middle retainer can slide over the inner housing **24** and hold the elements in position inside the motorized
5 gyroscopic weapon stabilizer **10**. The middle retainer can also positively engage into a groove in the inner housing **24** for fixed positioning. The rear bearing **46** slides over the inner housing **24** and is pressed inside the rotor **30**. The rear bearing **46** is positively positioned inside the rotor **30** by an internal formed shoulder in the rotor **30**. The rear bearing **46** may be several types of construction, including but not limited to a ball, wheel, roller, radial ball, angular
10 contact, tapered roller, spherical roller, cylindrical roller, pillow block, thrust roller, needle roller, or non contact bearing. The bearing materials may be varied and include, but are not limited to; metal, plastic, non ferrous or ceramic construction. The rotor **30** forms the spinning mass of the gyroscopic assembly, and the outside of the brushless motor, and may be constructed of a variety of materials. Traditional brushless motors are designed to make the
15 motor shaft and attached outer rotor housing rotate. This is accomplished by having the inner stator and windings fixed in place. The outer rotor housing with its attached magnets and the attached shaft are designed to rotate freely around the fixed stator. In this motorized gyroscopic weapon stabilizer **10**, the inner housing **24** functions as a brushless motor shaft, and the rotor **30** is made to rotate, creating the gyroscopic force. The inner housing **24** in this
20 device does not rotate. The rotor **30** has both front bearing **32** and rear bearing **46** pressed inside of it, and magnets **26** are internally bonded to the inner surface of the rotor **30** which is designed to spin at a significant speed. The front retainer **34** slides over the inner housing **24** and holds the elements in position inside the motorized gyroscopic weapon stabilizer **10**. The front retainer **34** positively engages into a groove in the inner housing **24** for fixed positioning.
25 The rear ring seal **40** and the front ring seal **50** are designed to compress between the inner housing **24** and the outer housing **36** to form a water resistant seal, protecting the inner workings of the motorized gyroscopic weapon stabilizer **10** from the elements. The outer housing **36** is rigidly attached to the inner housing **24**. The attachment of the inner housing **24** to the outer housing **36** may be made in many different ways, but is illustrated by way of
30 example as a threaded attachment. The outer housing **36** provides protection to the internal

elements of the motorized gyroscopic weapon stabilizer **10**. The outer housing **36** may be constructed of a wide variety of different materials. The rear spring **28** provides protection of the inner bearings and mechanical elements from the recoil forces generated when firing the weapon. The front spring **48** provides additional protection of the inner bearings and mechanical elements from the recoil forces generated when firing the weapon.

FIGURE 4 illustrates an alternative mounting position of the motorized gyroscopic weapon stabilizer **10** by way of example in front of the barrel **14** of a rifle type weapon **12**. In this illustration, the motorized gyroscopic weapon stabilizer **10** is shown mounted in front of the barrel **14**, extending the overall length of the weapon **12**. Due to the open core design of this device, the motorized gyroscopic weapon stabilizer **10** is configured to perform additional functions by incorporating other barrel **14** related accessories into the design of the device, such as, but not limited to; flash suppressors, muzzle breaks, and or sound suppressors, gas tubes, or anything used in conjunction with the barrel **14** or target alignment – line of sight **52** function of the weapon **12** which would benefit by the open core construction of this device.

FIGURE 5 illustrates the motorized gyroscopic weapon stabilizer **10** by way of example rigidly attached to a pistol type weapon **12**, showing the flexibility of the devices design. Because pistol type weapons **12** vary in configuration significantly, the method of attachment to the pistol type weapon **12** will vary as well. This illustration also shows how the target alignment – line of sight **52** is above the motorized gyroscopic weapon stabilizer **10**, while the axis of the projectile exit **16** is aligned through the motorized gyroscopic weapon stabilizer **10** allowing the projectile to pass through it. It is also contemplated that the motorized gyroscopic weapon stabilizer **10** can be mounted to a wide variety of weapons and configured to allow either the target – alignment line of sight **52**, or the axis of the projectile exit **16** to pass through the open core in the motorized gyroscopic weapon stabilizer **56**, or both simultaneously.

FIGURE 6 illustrates the motorized gyroscopic weapon stabilizer **10** by way of example rigidly attached to the barrel **14** of a rifle type weapon **12**. Because rifle type weapons **12** vary in configuration significantly, the method of attachment to the rifle type weapon **12** will vary as well. In this example, the target alignment – line of sight **52** passes

through the sighting mechanism **54** which by way of example and includes, but is not limited to a telescopic type alignment device. By way of example, the target alignment – line of sight **52** in this drawing does not pass through the motorized gyroscopic weapon stabilizer **10**, although the motorized gyroscopic weapon stabilizer **10** is attached by way of example to the rifle type weapon **12** barrel **14**, allowing the projectile to pass through the open core in the motorized gyroscopic weapon stabilizer **56**.

FIGURE 7 illustrates the motorized gyroscopic weapon stabilizer **10** as mounted by way of example to a rifle type weapon **12**. It is mounted to the barrel **14** of the weapon **12** by a support for the motorized gyroscopic weapon stabilizer **58**, allowing the target alignment – line of sight **52** of the sighting mechanism **54** to pass through the opening in the motorized gyroscopic weapon stabilizer **56**. In this configuration, the projectile does not pass through the open core of the motorized gyroscopic weapon stabilizer **10**, but the target alignment – line of sight **52** does.

The invention has been described with reference to the preferred embodiments. Modifications and alterations may occur to others upon reading and understanding the preceding detailed description. It is intended that the invention be constructed as including all such modifications and alterations insofar as they come within the scope of the appended claims or the equivalents thereof.

**THE EMBODIMENTS OF THE INVENTION IN WHICH AN EXCLUSIVE
PROPERTY OF PRIVILEGE IS CLAIMED ARE DEFINED AS FOLLOWS:**

1. A gyroscopic stabilizer system for weaponry, the system comprising:
5 a hollow core mass element having a bore extending therethrough mounted by at least one bearing for rotation around an axis of rotation extending through the bore; and
a mounting structure configured to mount the mass element and bearings to an associated weapon such that the axis of rotation is parallel to an axis of a trajectory of a fired projectile;
10 wherein the mounting structure includes a tubular inner housing about which the at least one bearing is supported, the tubular inner housing member extending at least partially into the bore of the hollow core mass element.
2. The system according to claim 1, wherein the mass element is cylindrical and the
15 mounting structure is configured to mount the mass element and the at least one bearing for rotation around the trajectory of the fired projectile and/or a line of sight.
3. The system according to claim 1, wherein the mounting structure is configured to
20 mount the mass element and the at least one bearing to an accessory which is either permanently affixed or temporarily affixed to the weapon, the accessory including at least one of a flash suppressor, a sighting mechanism, a laser, a muzzle brake, a sound suppressor, a gas tube, or a compensator.
4. The system according to claim 1, further including an electric motor which rotates the
25 mass element around the axis of rotation.
5. The system according to claim 1, wherein the associated weapon includes at least one of a single shot, semi-automatic, and fully automatic weapon.

6. The system according to claim 1, wherein the mounting structure mounts the mass element such that the axis of rotation is parallel to and displaced from the axis of the trajectory of the fired projectile and/or a line of sight.

5 7. The system according to claim 1, wherein the mounting structure mounts the at least one bearing and the mass element to the end of a barrel of the associated weapon.

8. The system according to claim 1, wherein the mass element is cylindrical to define an interior bore and wherein the mounting structure mounts the mass element and the at least one
10 bearing such that either the projectile passes through the bore of the mass element or a sighting mechanism sights through the bore of the mass element.

9. A method for stabilizing a weapon, the method comprising:
mounting a mass element by at least one bearing for rotation 'around an axis of
15 rotation, the mass element having a bore extending therethrough with the axis of rotation extending through the bore;
mounting the mass element and the at least one bearing to a weapon such that the axis of rotation is parallel to an axis of a trajectory of a fired projectile, with the axis of trajectory passing through the bore; and
20 rotating the mass element around the axis of rotation;
wherein the at least one bearing and the mass element are mounted to the end of a barrel of the weapon.

10. The method according to claim 9, wherein the mass element is cylindrical and the
25 mounting of the mass element and the at least one bearing for rotation is around the trajectory of the fired projectile and/or a line of sight.

11. The method according to claim 9, wherein the mounting of the mass element and the at least one bearing is to an accessory which is either permanently affixed or temporarily affixed
30 to the weapon, the accessory including at least one of a flash suppressor, a sighting mechanism, a laser, a muzzle brake, a sound suppressor, a gas tube, and a compensator.

12. The method according to claim 9, wherein the weapon includes at least one of a single shot, semi-automatic, and fully automatic weapon.

5 13. The method according to claim 9, wherein the mass element is mounted such that the axis of rotation is parallel to and displaced from the axis of the trajectory of the fired projectile.

14. A method for stabilizing a weapon, the method comprising:

10 mounting a mass element by at least one bearing for rotation around an axis of rotation, the mass element having a bore extending therethrough with the axis of rotation extending through the bore;

mounting the mass element and bearings to a weapon such that the axis of rotation is parallel to an axis of a trajectory of a fired projectile, with the axis of trajectory passing
15 through the bore; and

rotating the mass element around the axis of rotation;

wherein the mass element is cylindrical to define an interior bore and wherein the mass element and the at least one bearing are mounted such that either a projectile passes through the bore of the mass element or a sighting mechanism sights through the bore of the mass
20 element.

15. The system according to claim 1, further comprising an outer housing, the outer housing and inner housing being secured together, wherein the rotating mass is enclosed within the inner housing and the outer housing.

25

16. The system according to claim 15, wherein the inner housing are sealed together forming a watertight compartment in which the rotating mass is enclosed.

17. The system according to claim 1, wherein the rotating mass comprises a rotor portion
30 of an electric motor.

18. The system according to claim 1, wherein the rotating mass is mounted in at least one of a position spaced longitudinally from a barrel of the associated weapon, coextensive with a barrel of the associated weapon, and surrounding a barrel of the associated weapon with at least a portion of the barrel within the bore of the hollow core mass element.

Fig.1

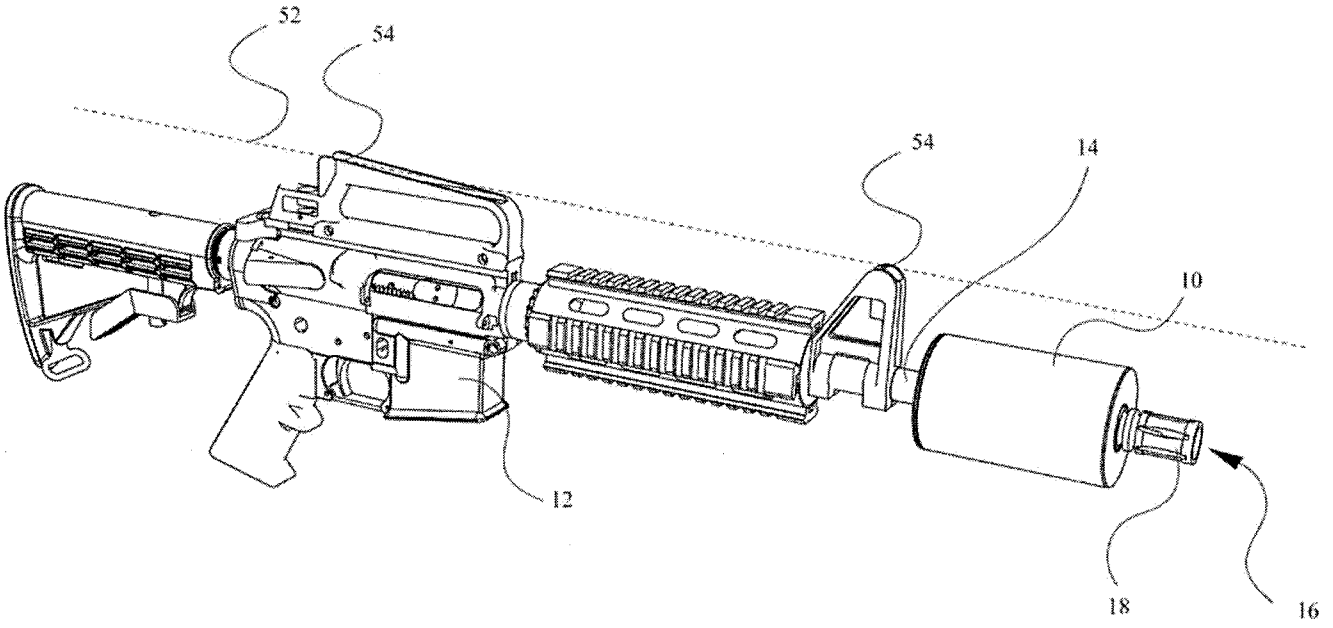
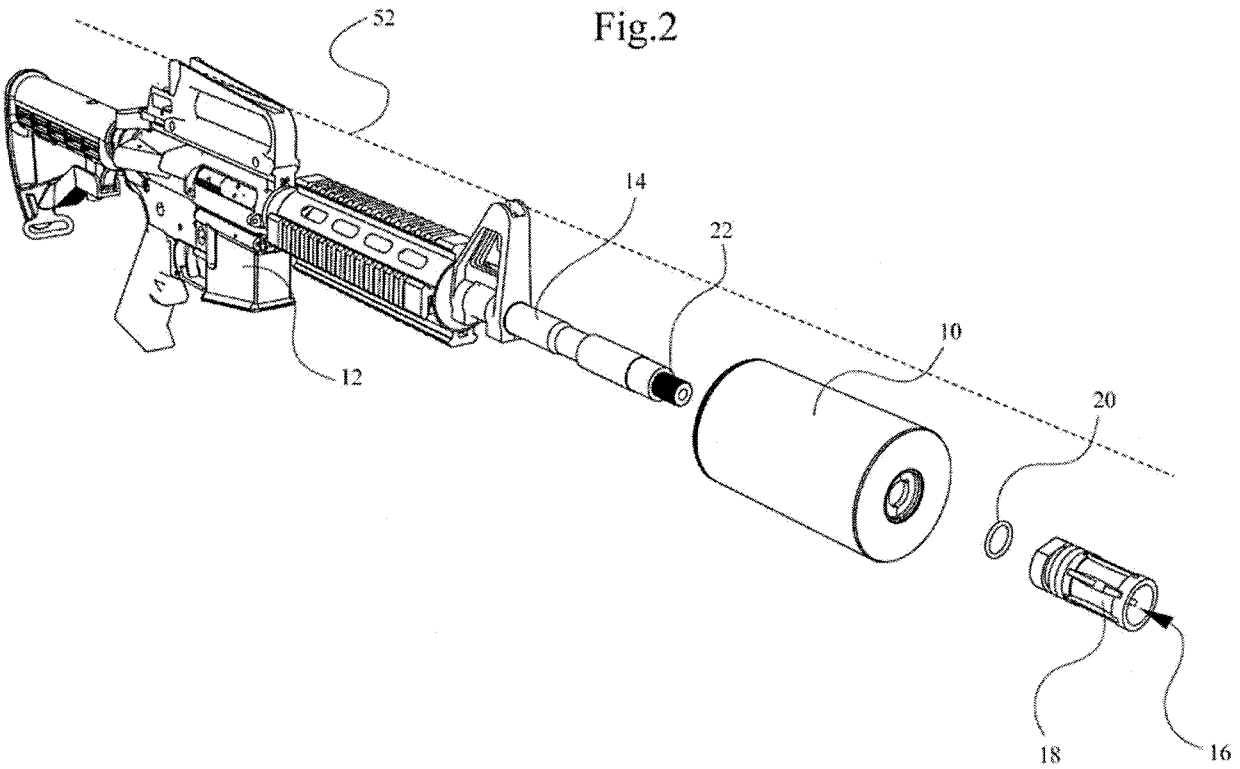

Fig.2



2/4

Fig.3

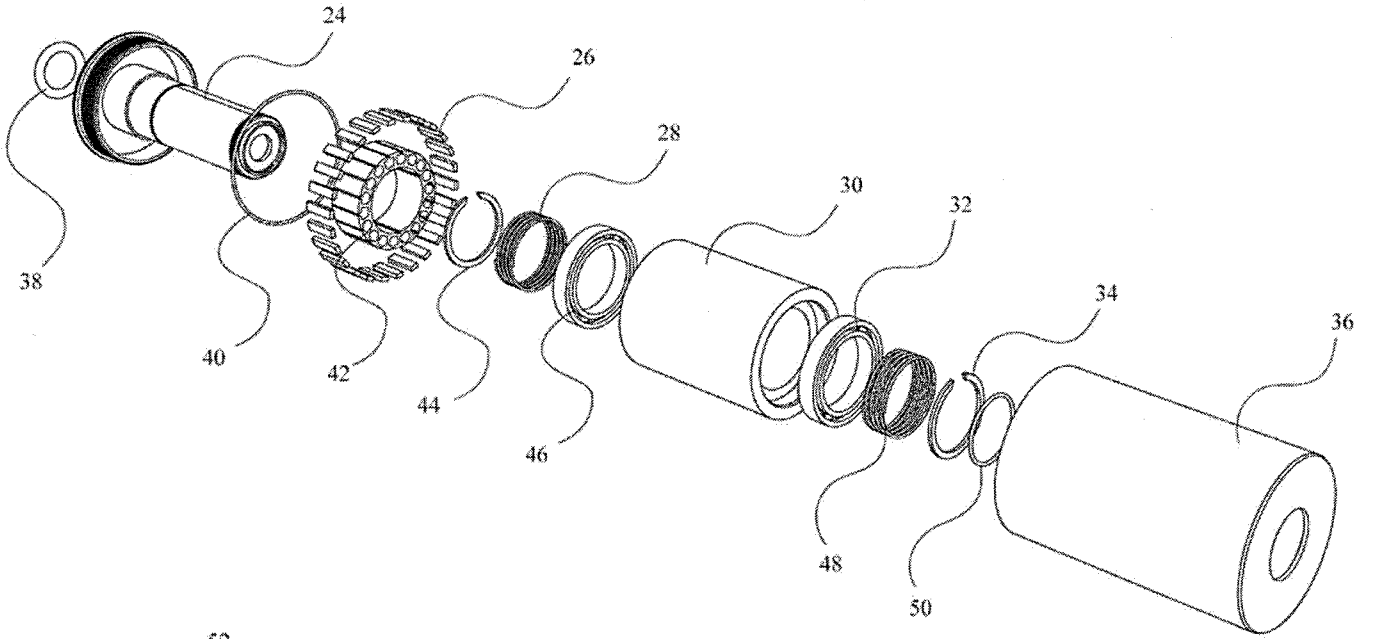

Fig.4

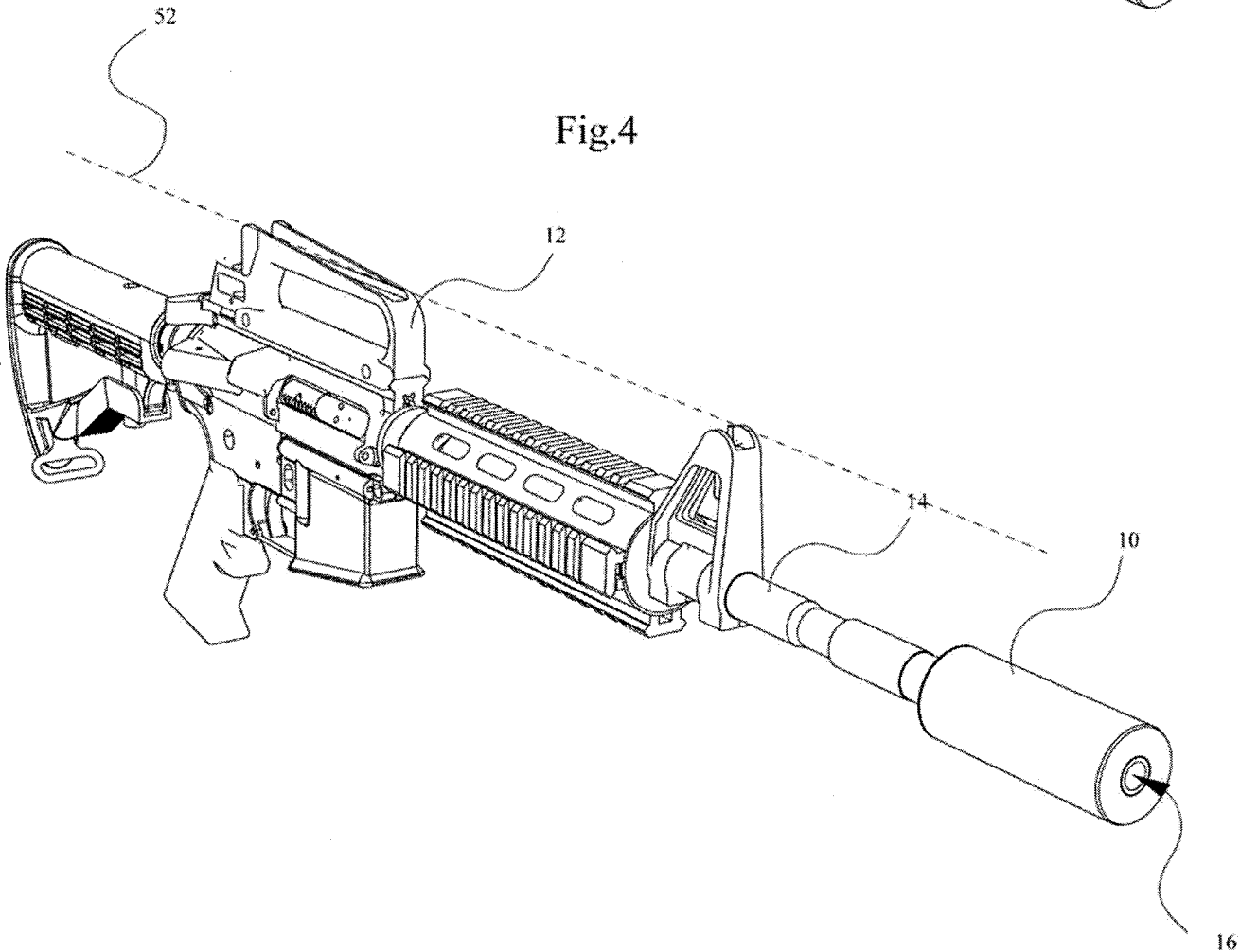

Fig.5

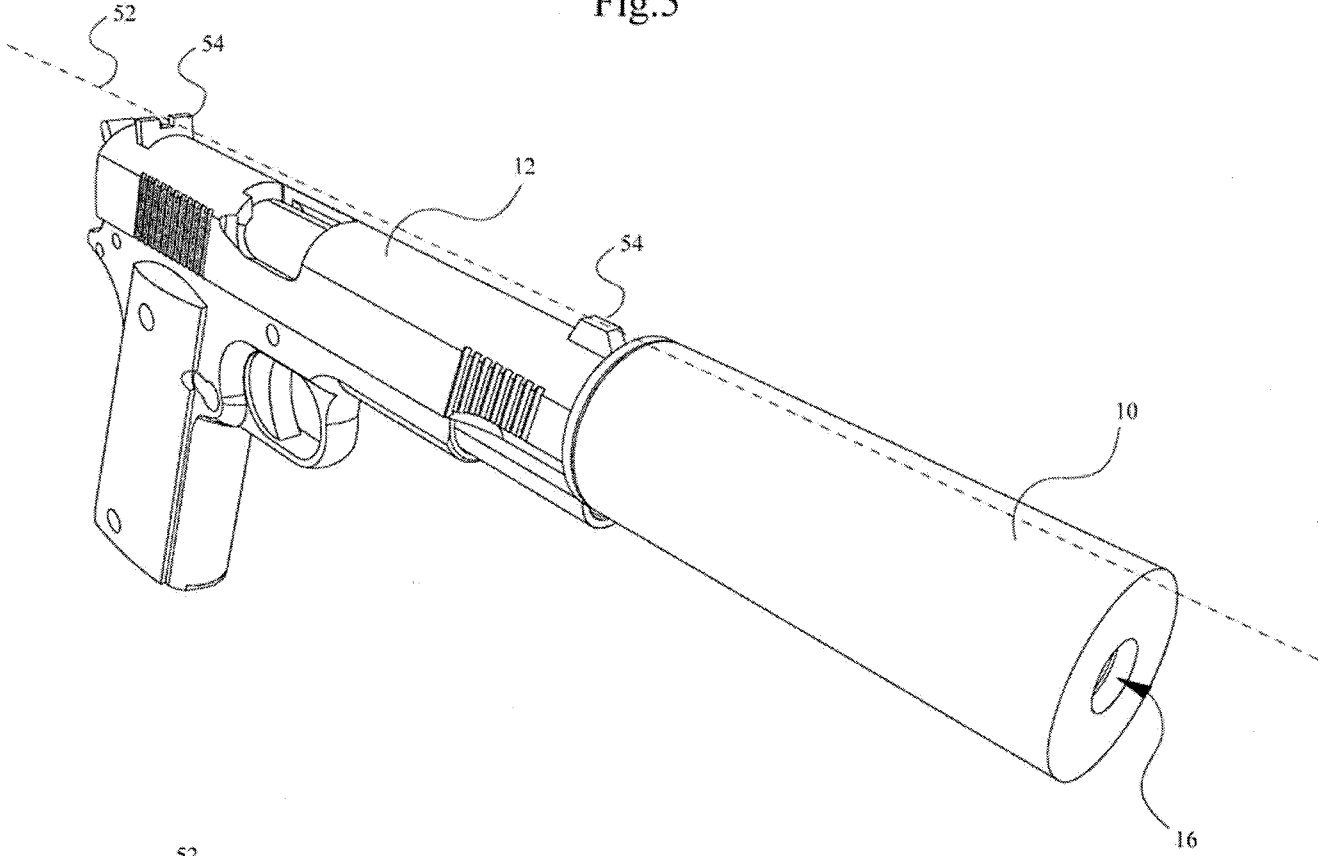

Fig.6

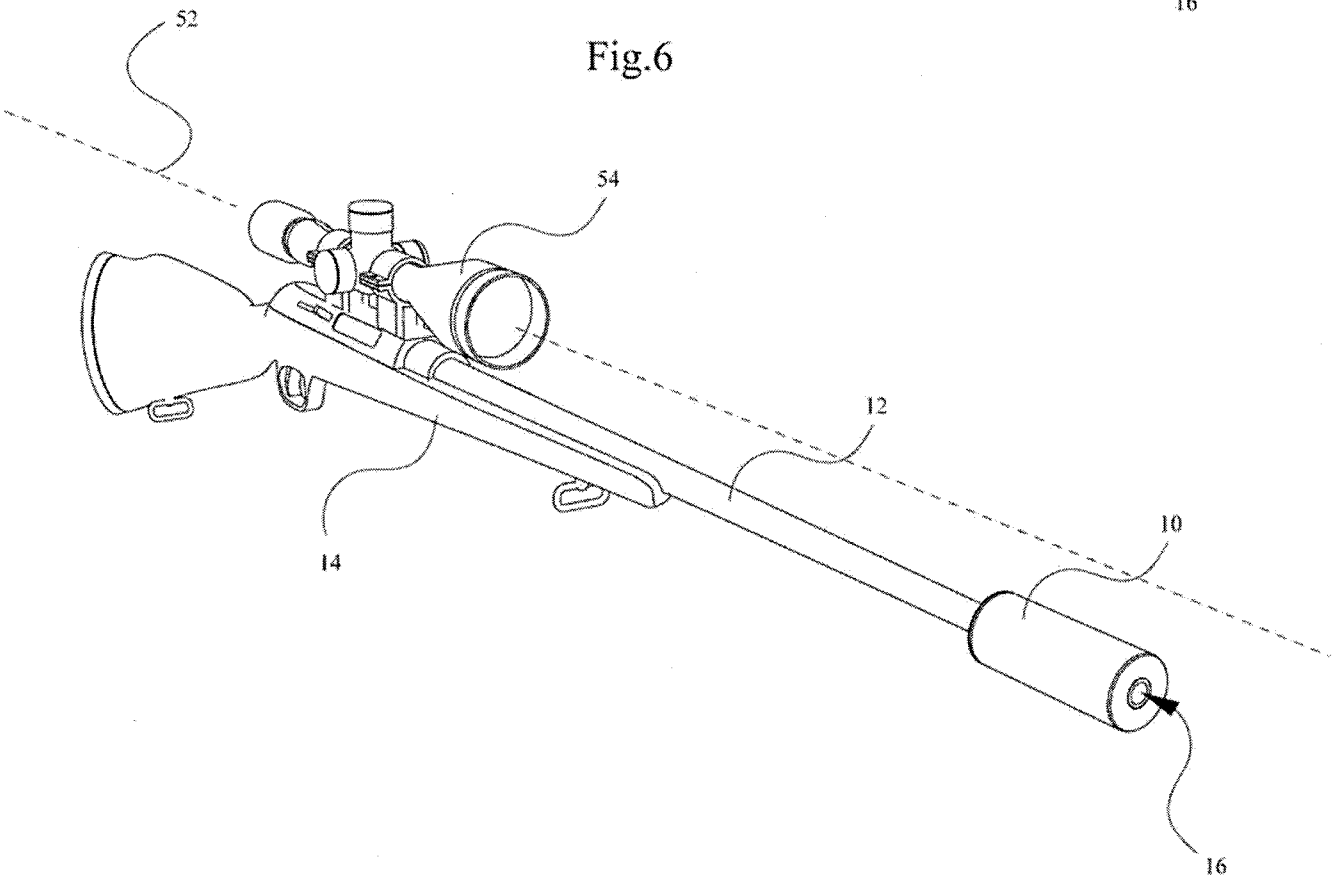

Fig.7

