



(11) **EP 2 056 031 A1**

(12) **EUROPEAN PATENT APPLICATION**

(43) Date of publication:
06.05.2009 Bulletin 2009/19

(51) Int Cl.:
F24F 11/00^(2006.01)

(21) Application number: **08251876.2**

(22) Date of filing: **29.05.2008**

(84) Designated Contracting States:
**AT BE BG CH CY CZ DE DK EE ES FI FR GB GR
HR HU IE IS IT LI LT LU LV MC MT NL NO PL PT
RO SE SI SK TR**
Designated Extension States:
AL BA MK RS

(72) Inventor: **Lee, Hee Jun**
Changwon-si
Kyungsangnam-do 641-110 (KR)

(30) Priority: **30.10.2007 KR 20070109662**

(74) Representative: **Palmer, Jonathan R.**
Boult Wade Tennant
Verulam Gardens
70 Gray's Inn Road
London WC1X 8BT (GB)

(71) Applicant: **LG Electronics Inc.**
Yongdungpo-gu
Seoul (KR)

(54) **Error management system of air conditioner**

(57) An error management system of an air conditioner can send back a countermeasure against errors in advance before a service man is sent out from a service center, or allows a central controller to display a simple

countermeasure against errors in advance. Accordingly, the user can quickly take countermeasures against an error of the air conditioner.

EP 2 056 031 A1

Description

[0001] The present invention relates to an error management system of an air conditioner, and more particularly, to an error management system of an air conditioner, which can quickly take countermeasures against an error of the air conditioner.

[0002] Generally, an error management system of an air conditioner includes an air conditioner including at least one indoor unit and at least one outdoor unit connected to the indoor unit and a controller for monitoring operating states of the respective indoor and outdoor units and collectively or individually controlling the operations thereof.

[0003] However, the error management system of the air conditioner according to the conventional art has the problem that, if an error of the air conditioner is detected, a user can not find information about errors or a countermeasure against errors, thus causing inconvenience until a service man who performs the repair and maintenance of air conditioners arrives, and slowing down the repair of the air conditioner.

SUMMARY OF THE INVENTION

[0004] It would be desirable to provide an error management system of an air conditioner, which can send back a countermeasure against errors in advance before a service man is sent out from a service center, or allows a central controller to display a simple countermeasure against errors in advance.

[0005] The present invention provides an error management system of an air conditioner, comprising an air conditioner; and a central controller for detecting an error of the air conditioner based on a first error information among operational informations received from the air conditioner and transmitting the first error information to a service center, and receiving return countermeasure information corresponding to the first error information from the service center.

[0006] The error management system of the air conditioner according to the present invention can quickly take countermeasures against an error state because information about errors generated in the air conditioner is transmitted to the service center, and the service center sends back a countermeasure against errors in advance before a service man is sent out.

[0007] Furthermore, a user can quickly take countermeasures against an error because the central controller can display a simple countermeasure against errors in advance before the central controller transmits error information to the service center.

BRIEF DESCRIPTION OF THE DRAWINGS

[0008] The accompanying drawings, which are included to provide a further understanding of the invention and are incorporated in and constitute a part of this applica-

tion, illustrate embodiment(s) of the invention and together with the description serve to explain the principle of the invention. In the drawings:

5 FIG. 1 is an overall configuration view of an error management system of an air conditioner in accordance with one embodiment of the present invention; FIG. 2 is a view showing the configuration of an email transmission system between a central controller and a service center as shown in FIG. 1;

10 FIG. 3 is a block diagram showing the internal configuration of the central controller as shown in FIG. 1; FIG. 4 is a block diagram showing the internal configuration of an error control unit of the air conditioner as shown in FIG. 3;

15 FIG. 5 is a view showing the configuration of a display unit in accordance with a first embodiment of the central controller as shown in FIG. 3;

20 FIG. 6 is a view showing the configuration of a display unit in accordance with a second embodiment of the central controller as shown in FIG. 3;

25 FIG. 7 is a block diagram showing the internal configuration of the service center as shown in FIG. 1; FIG. 8 is a view showing the configuration of a display unit in accordance with a third embodiment of the central controller as shown in FIG. 3;

30 FIG. 9 is a view showing the configuration of a display unit in accordance with a fourth embodiment of the central controller as shown in FIG. 3;

DETAILED DESCRIPTION OF THE PREFERRED EMBODIMENTS

[0009] FIG. 1 is an overall configuration view of an error management system of an air conditioner in accordance with one embodiment of the present invention. FIG. 2 is a view showing the configuration of an email transmission system between a central controller and a service center as shown in FIG. 1.

35 **[0010]** Referring to FIG. 1, the error management system of the air conditioner includes an air conditioner 200, a central controller 100, and a service center 300. The air conditioner includes an indoor unit 220 disposed in an indoor space and an outdoor unit 210 disposed in an outdoor space. The indoor unit 220 and the outdoor unit 210 are communicatively connected to each other via a network. The present invention is not limited thereto, but the air conditioner 200 may include one outdoor unit and a plurality of indoor units, or, as shown in FIG. 1, may include a plurality of outdoor units 210 and a plurality of indoor units 220.

40 **[0011]** The indoor units 220 are respectively disposed in indoor spaces, and the outdoor unit 210 is disposed in an outdoor space. In each air conditioner 200, the indoor units 220 and the outdoor unit 210 are communicatively connected via a network through cables. Here, the network is an RS-485 communication. The 'RS-485 communication' is one of interface protocols for serial com-

55

munication and a standard for multipoint communication lines. However, the present invention is not limited thereto.

[0012] The central controller 100 is connected to the outdoor unit 210 of the air conditioner 200 to monitor an operating state of the air conditioner 200 and collectively and individually control the operation thereof. The central controller 100 may be comprised of an external input device to be connected to the outdoor unit 210 through a communication line, and is communicatively connected to the outdoor unit 210 in order to control the operation of the indoor unit 210 disposed in the indoor space. Here, the central controller 100 and the outdoor unit 210 can send and receive data in a variety of ways, including a power line, wireless communication, and LAN as well as RS-485 through cables. Hence, between the central controller 100 and the outdoor unit 210, there may be further included a protocol converter 150 for converting data sent and received between the central controller 100 and the outdoor unit 210 and data sent and received between the outdoor unit 210 and the indoor unit 220 to and from each other.

[0013] The central controller 100 receives operational informations from the air conditioner 200 in order to monitor the operating state of the air conditioner 200. The central controller 100 detects an error of the air conditioner based on the first error information among received operational informations. The first error information is information of an error code format about the cause or type of an error when an error occurs to the air conditioner, and is stored in a memory unit (not shown) within the air conditioner 100. When an error occurs to the air conditioner 200, the air conditioner 200 transmits, to the central controller 100, the first error information of an error code format corresponding to the occurred error.

[0014] As shown in FIG. 1, the central controller 100 transmits the first error information to the service center 300 located at a remote place, and the service center 300 sends back return countermeasure information corresponding to the first error information to the central controller 100. Specifically, the central controller 100 notifies the service center 300 of the first error information to be transmitted from the air conditioner 200. The format of notification can be an error message in a SMS format or in a format like email via the Internet network as a basic format, but not limited thereto. Referring to FIG. 2, with a sender S_F and a receiver R_F set, an email Me reaches a communication module (310 of FIG. 7) of the service center 30 in an SMTP (Small Mail Transfer Protocol) method. The user of the central controller 100 can be set as the sender S_F. The communication module 310 of the service center 300 may be a website operated by the service center 300 or a receiving server such as a mail server. The email Me contains the first error information E_F, and the service center 300 can clearly find the cause of error occurrence through the email Me transmitted and accumulated. After finding the cause of error occurrence, the service center 300 sends back return countermeas-

ure information corresponding to the first error information to the central controller 100. The sendback format may be the SMS format or the format like email via the Internet network as mentioned above. However, the present invention is not limited to the above-stated communication method.

[0015] FIG. 3 is a block diagram showing the internal configuration of the central controller as shown in FIG.1. FIG. 4 is a block diagram showing the internal configuration of an error control unit of the air conditioner as shown in FIG. 3.

[0016] As shown in FIG. 3, the central controller 100 includes a database 130, a display unit 150, a control unit 120, and a communication module 140. The communication module 140 sends and receives data to and from the air conditioner 140 or the service center 300, and the control unit 120 monitors the operation state of each air conditioner 200 and detects and diagnoses an error by using operational information of the air conditioner 200 received via the communication module 140.

[0017] Further, the central controller 100 further includes a control program 110 for controlling the overall operation of the central controller 100 and providing an interface for operation control to the user of the central controller 100.

[0018] The control unit 120 includes a main control unit 121 for monitoring the state of each air conditioner 200, generating a control signal for operation control according to a control command or setting inputted through the control program 110, and transmitting it to the corresponding outdoor unit 210 or indoor unit 220, and an error control unit 122 for detecting and diagnosing an error of each air conditioner 200 through operational information stored in a state information DB 131, and generating a resultant error message and transmitting it to the service center 300.

[0019] Referring to FIG. 4, the error control unit 122 further includes an error detection unit 122a for detecting an error of each air conditioner from the first error information among the operational informations, an error diagnosis unit 122b for diagnosing the error detected in the error detection unit 122a, and giving the respective error information a predetermined error level according to the degree of the error, and an error notification module for converting the first error information with an error level given by the error diagnosis unit 122b so as to be transmitted to the service center in an error message in a SMS format or in a format like email through the Internet network.

[0020] The error detection unit 122a is a module for detecting an error of each air conditioner 200. When the first error information of an error code format is received from the air conditioner 200, it is compared with an error information list stored in the database 130 to judge that an error of the corresponding air conditioner 200 is detected. A concrete method of detecting an error can be implemented in various ways other than the above-described method.

[0021] The error diagnosis unit 122b is a module for giving the first error information judged in the error detection unit 122a a predetermined error level according to the degree of the error. The error level can be classified into an error that can be handled by the user of the central controller 100, a fatal error requiring immediate response from the service center 300 because the error has a fatal effect on the central controller 100, an error that can be solved when handled within a given number of days in the service center 300, and subsidiary management matters such as filter replacement and regular checkup. Here, an error level according to the degree of an error can be set to a variety of levels by the basic setting of the product upon release or the setting by a user.

[0022] The error notification module 122c generates an error message for the respective first error information with an error level given by the error diagnosis unit 122b. The error notification module 122c generates an error message containing the first error information, and the error message is transmitted to the service center 300 via the communication module 140. Here, the error notification module 122c can convert the first error information into an error message in an email via the Internet or in a SMS format as described above, but it is not limited to the above communication method.

[0023] Here, the error notification module 122c transmits the first error information to the service center 300 only when the respective first error information with an error level given has an error level higher than a preset error level. That is, all the first error information received from the air conditioner 200 is not transmitted to the service center 300, but only an error message containing the first error information of higher than a preset error level is transmitted to the service center 300. In a case where there occurs an error that does not require the repair of the air conditioner 200, or where a temporary error occurs, the error message containing the first error information to be transmitted to the service center 300 may cause overload. For example, since network failures are mostly temporary failures, the error state can be automatically recovered after the lapse of a predetermined time. Also, even though an error occurred during the manipulation and input by the user of the air conditioner 200 can be immediately corrected, error information relating to this reaches the service center 300, thereby causing inconvenience to both of the user and the service center 300. Accordingly, the central controller 100 transmits an error message containing the first error information to the service center 300 only when the first error information has an error level higher than a preset error level, and the service center 300 sends back return countermeasure information to the central controller 100 only when the first error information has an error level higher than a preset error level.

[0024] The database 130 stores operation information containing the first error information received from the air conditioner 200. The database 130 includes a state information DB 131 for classifying and storing the opera-

tional information received from each air conditioner according to each air conditioner or operating state and an error DB 132 for storing, as data, a plurality of error messages generated by diagnosis and classification through the error detection unit 122. The state information DB 131 stores operational information received from the air conditioner 200, and the operational information may include product information, setting information, state information, error information, user information, and so on of the air conditioner 200.

[0025] The error DB 132 stores the first error information and an error level corresponding to the respective first error information in a table format, and stores an error message diagnosed and classified in the error control unit 122. Also, the error DB 132 stores self countermeasure information corresponding to the first error information. Here, the self countermeasure information means a simple countermeasure corresponding to the respective first error information transmitted from the air conditioner 200, and the countermeasure is made into a database, stored in the error DB 132, and displayed to the outside through the display unit 150. Hence, it is possible to notify the user in advance of a simple countermeasure allowing the user to quickly take countermeasures until return countermeasure information is received from the service center 300 or until a service man comes.

[0026] Here, the self countermeasure information is a countermeasure based on the installation manual of the air conditioner 200. That is, the self countermeasure information is countermeasure information which is simple compared to the countermeasure information sent back from the service center 300, and is based on the range defined in the installation manual of the air conditioner 200 so as to allow the user to easily perform manipulations, such as the repair of the air conditioner 200. For example, since network failures are mostly temporary failures, the self countermeasure information may indicate being in standby for a while until a predetermined time is elapsed.

[0027] FIG. 5 is a view showing the configuration of a display unit in accordance with a first embodiment of the central controller as shown in FIG. 3. FIG. 6 is a view showing the configuration of a display unit in accordance with a second embodiment of the central controller as shown in FIG. 3.

[0028] The central controller 100 further includes a display unit 150 capable of displaying operational information of the air conditioner 200. When the operational information of the air conditioner 200 is received by the central controller 100, the control unit 120 transmits an output signal for displaying the operational information of the air conditioner 200 to the display unit 150, and the display unit 150 displays the operational information. Here, the display unit 150 can display at least one of the first error information transmitted from the air conditioner 200 and self countermeasure information 154 stored in the error DB 132. Referring to FIG. 5, the display unit 150 displays the first error information or the self counter-

measure information 154 through a pop-up window 151. When the first error information is received from the air conditioner 200, the first error information of an error code format and a user's simple countermeasure for this error are displayed, thereby enabling the user to quickly take countermeasures. The pop-up window 151 is a menu component disposed ahead of a basic menu 152 displaying the operational information of the air conditioner. When data relating to the first error information or self countermeasure information is transmitted to the display unit 150, it appears ahead of the basic menu 152. Referring to FIG. 5, if the degree of contamination of an air intake filter at the indoor unit side increases and thus the air intake filter needs to be replaced or cleaned, the first error information 153 of the error code format and the self countermeasure information 154 can be briefly displayed through the pop-up window 151. Referring to FIG. 6, the first error information 153 or the self countermeasure information 154 may be displayed in text rows 151 on the display unit 150, and the method of display on the display unit 150 is not limited to a display method using a pop-up window or text rows.

[0029] FIG. 7 is a block diagram showing the internal configuration of the service center as shown in FIG. 1.

[0030] Referring to FIG. 7, the error management system of the air conditioner according to the present invention includes a service center 300 for receiving the first error information from the central controller 100 and making repairs on this error. The service center 300 includes a communication module 310, a control unit 320, and a service DB 340.

[0031] The communication module 310 of the service center receives the first error information from the communication module 140 of the central controller, and forwards it to the control unit 320. The control unit 320 detects and diagnoses an error of each air conditioner 200 through the forwarded first error information, and generates return countermeasure information corresponding to the first error information. Although the return countermeasure information is data stored in the service DB 340, it may be data generated in the control unit 320. The return countermeasure information is sent back to the central controller 100 via the communication module 310, and stored in the error DB 132 of the central controller. The display unit 150 of the central controller displays the return countermeasure information to the outside. This can be displayed on the display unit 150 through the above-described pop-up window or text rows.

[0032] The service DB 340 stores inherent information of the user 160 of each air conditioner 200. Here, the communication module 310 of the service center can send the return countermeasure information to the email of the user 160 by using the inherent information of the user 160 stored in the service DB 340 or transmit it to the mobile communication terminal of the user 160 in a SMS format, as well as sending back the return countermeasure information to the central controller 100.

[0033] FIG. 8 is a view showing the configuration of a

display unit in accordance with a third embodiment of the central controller as shown in FIG. 3. Referring to FIG. 8, the return countermeasure information 155 includes error details and an error recovery method that correspond to the first error information. That is to say, the return countermeasure information 155 includes the details of an error occurred at the moment in the air conditioner and a concrete error recovery method for allowing the user 160 to recover the error themselves. Therefore, the user 160 can quickly perform a manipulation for error recovery without needing to wait for a service man who makes repairs on the air conditioner to come. The return countermeasure information 155 may include service information for making repairs on the air conditioner 200. Here, the service information includes repair schedule information of a service man 400. The repair schedule information includes a list of service men who are available to be sent out at the moment, the time taken for a service man to be sent out for repair, an expected time of arrival to a service location, the time or cost taken for repair, the contact number of the service man, the schedule of the service man, etc. Accordingly, the time, cost, and so forth taken for the repair of the air conditioner can be easily expected because various at-the-moment information of a service man can be found.

[0034] When an error message containing the first error message is received, the communication module 310 of the service center can transmit the error message in a SMS format to the mobile communication terminal of the service man 400 who makes repairs on the air conditioner. By notifying the service man 400 of the first error information, the service man 400 can quickly take a countermeasure for the repair of the air conditioner.

[0035] In accordance with another aspect of the present invention, an error management system of an air conditioner according to the present invention may include an air conditioner 200 and a central controller 100 for detecting an error of the air conditioner 200 based on operational information received from the air conditioner 200 and generating second error information based on the first error information corresponding to the detected error. The basic configurations of a central controller and a service center to be described later are the same as those described above, so descriptions will be focused on differences with the above-described embodiments.

[0036] FIG. 9 is a view showing the configuration of a display unit in accordance with a fourth embodiment of the central controller as shown in FIG. 3. When the first error information is received from the air conditioner 200 via the communication module 140 of the central controller, the error control unit 122 transmits self countermeasure information 154 stored in the error DB 132 to the display unit 150, and the self countermeasure information 154 is displayed through the above-mentioned pop-up window 151 or text rows (not shown) on the screen of the display unit 150. Here, the self countermeasure information 154 is a countermeasure based on the installation manual of the air conditioner as described above,

and a detailed description thereof will be omitted.

[0037] While the first error information is information of an error code format relating to the cause or type of an error upon occurrence of an error in the air conditioner, and is stored in a memory unit (not shown) within the air conditioner, the second error information is information substituted into the form of a language in which the user can recognize the first error information of an error code format. The second error information corresponding to the respective first error information is made into a table and stored in the error DB 132 of the central controller. When the first error information is received, the error control unit 122 searches the table for second error information corresponding to the first error information among the second error information stored in the error DB 132, and calls for the second error information corresponding to the first error information. The second error information generated in the error control unit 122 may be transmitted to the service center 300 via the communication module 140, or transmitted to the display unit 150 for display.

[0038] Referring to FIG. 9, the first error information of an error code format is substituted into second error information 156 in English, i.e., a language that the user can recognize, and displayed through a pop-up window 151 of the display unit. Here, the display unit 150 can display at least one of the second error information 156 and the self countermeasure information 154. Therefore, the user who could not find concrete error details through the first error information of an error code format can find the details of an error through the second error information 156 and take a simple countermeasure against the error through the self countermeasure information 154. The self countermeasure information 154 can be displayed through text rows (not shown) as described above, as well as through the pop-up window 151.

[0039] Meanwhile, the central controller 100 transmits the second error information to the service center 300 only when the first error information or second error information has an error level higher than a preset error level. As discussed above, it is not that all the second error information generated based on the first error information is transmitted to the service center 300, but only the first error information or second error information having an error level higher than a preset level is transmitted to the service center 300, thereby preventing the overload of the first error information transmitted to the service center 300 due to the occurrence of an error not requiring the repair of the air conditioner 200 or a temporary error.

[0040] Meanwhile, the communication module 310 of the service center receives the first error information or the second error information from the central controller 100, and sends return countermeasure information corresponding to the first error information or second error information back to the central controller 100. The error DB 132 of the central controller stores the return countermeasure information transmitted from the service center 300 therein, and displays it through the display unit 150. As described above, the return countermeasure

information can be displayed on the display unit 150 through a pop-up window or text rows. Here, the display unit 150 can display at least one of the second error information and the return countermeasure information, and the user can find the details of the error through the second error information, and can take concrete countermeasures against the error.

[0041] Although the present invention has been described with reference to the embodiments shown in the drawings, these are merely illustrative, and those skilled in the art will understand that various modifications and equivalent other embodiments of the present invention are possible.

Claims

1. An error management system of an air conditioner, comprising:
 - an air conditioner 200; and
 - a central controller 100 for detecting an error of the air conditioner based on a first error information among operational informations received from the air conditioner and transmitting the first error information to a service center 300, and receiving a return countermeasure information corresponding to the first error information from the service center.
2. The error management system of claim 1, wherein the central controller receives the return countermeasure information from the service center only when the first error information has an error level higher than a preset error level.
3. The error management system of claim 1, wherein the central controller comprises:
 - a main control unit 121 for monitoring the state of each air conditioner, and generating a control signal for operation control; and
 - an error control unit 122 for detecting an error through the first error information among the operational informations and transmitting the first error information to the service center.
4. The error management system of claim 3, wherein the error control unit further comprises an error notification module 122c for converting the first error information into an error message in email via the Internet or in a SMS format in order to transmit the first error information to the service center.
5. The error management system of claim 1, wherein the central controller comprises:
 - a database 130 for storing a self countermeas-

- ure information corresponding to the first error information; and
a display unit 150 for displaying at least one of the first error information and the self countermeasure information. 5
6. The error management system of claim 5, wherein at least one of the first error information and the self countermeasure information is displayed on the display unit through a pop-up window or text rows. 10
7. The error management system of claim 1, wherein the central controller comprises:
a database 130 for storing the return countermeasure information sent back from the service center; and
a display unit 150 for displaying the return countermeasure information stored in the database. 15
20
8. The error management system of claim 7, wherein the self countermeasure information is displayed on the display unit through a pop-up window or text rows. 25
9. The error management system of claim 1, wherein the service center comprises a service DB 340 for storing an inherent information of the user of the air conditioner, wherein the service center sends the return countermeasure information to the email of the user by using the inherent information of the user stored in the service DB or transmitting the same to the mobile communication terminal of the user in a SMS format. 30
35
10. The error management system of claim 1, wherein the return countermeasure information includes error details and an error recovery method that correspond to the first error information. 40
11. The error management system of claim 1, wherein the return countermeasure information includes a service information for making repairs on the air conditioner. 45
12. The error management system of claim 11, wherein the service information includes a repair schedule information of a service man 400.
13. The error management system of claim 1, wherein the service center includes a communication module 310 for receiving the first error information, the communication module transmitting the first error information in a SMS format to the mobile communication terminal of a service man 400 for making repairs on the air conditioner. 50
55

FIG. 1

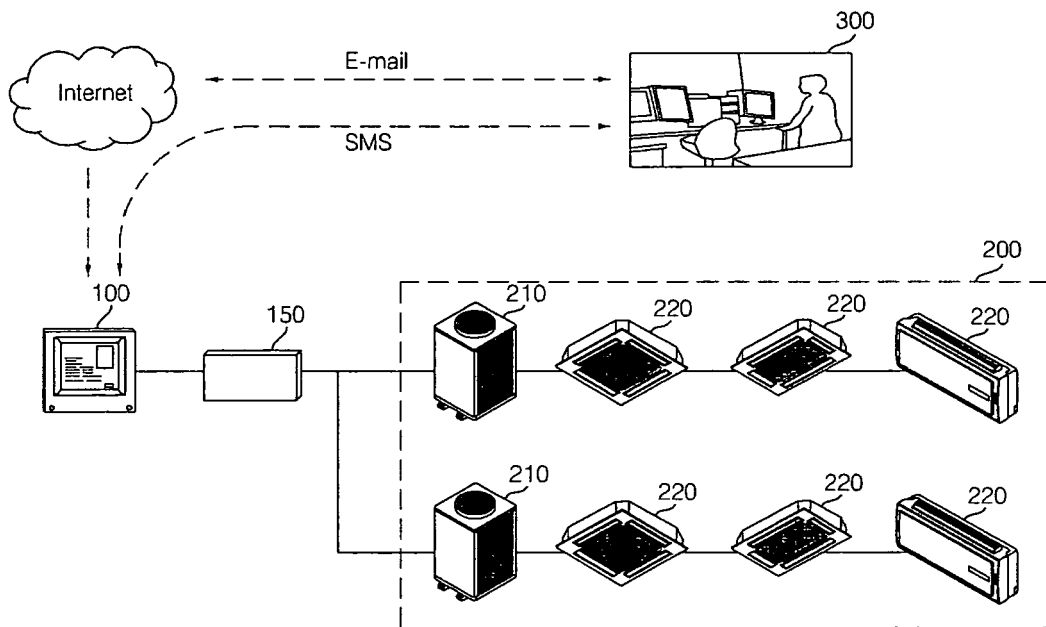

FIG. 2

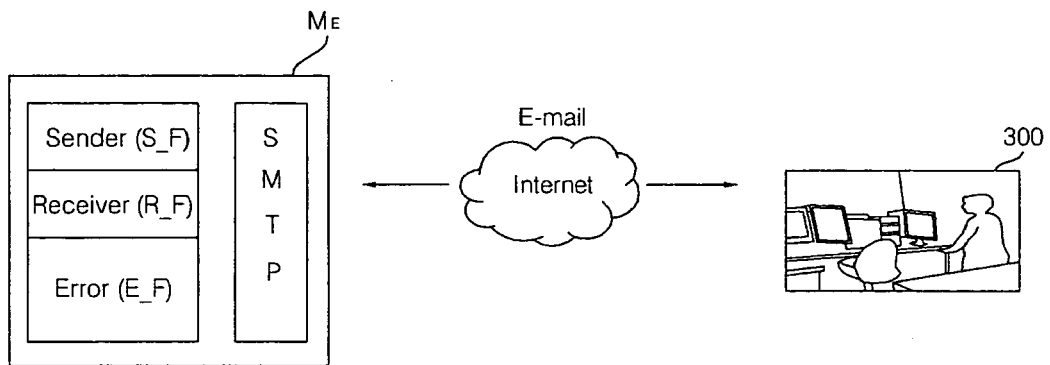

FIG. 3

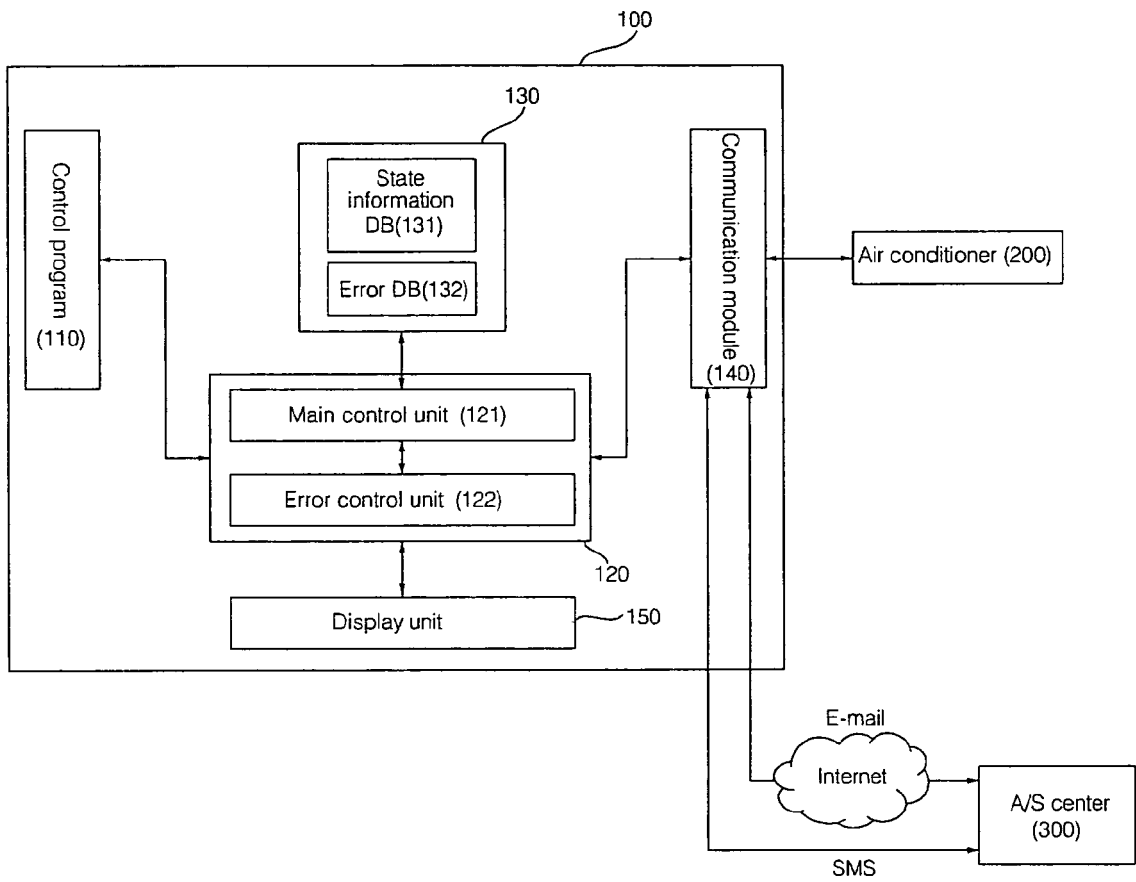

FIG. 4

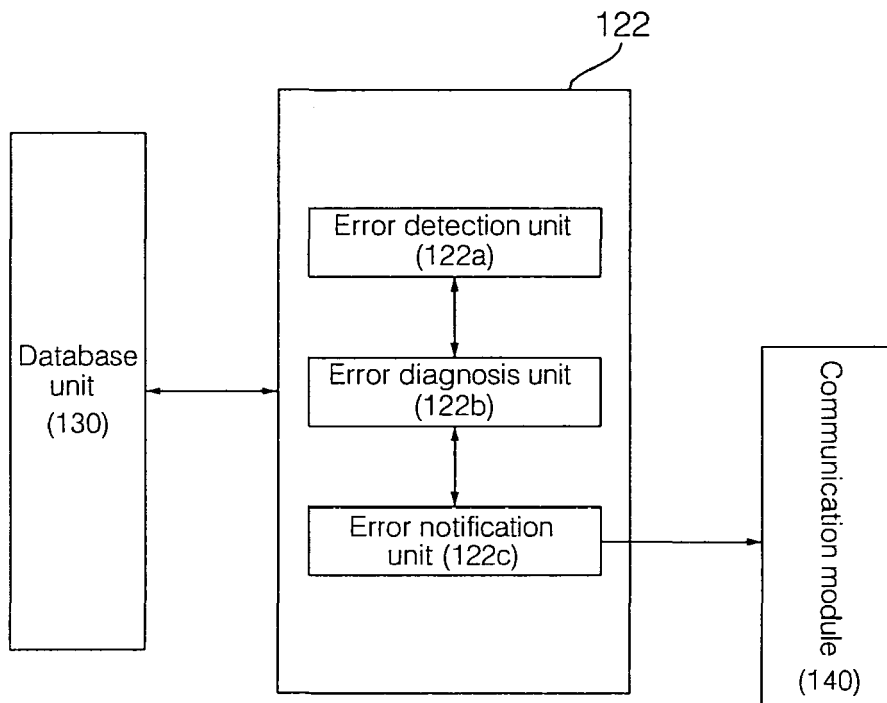

FIG. 5

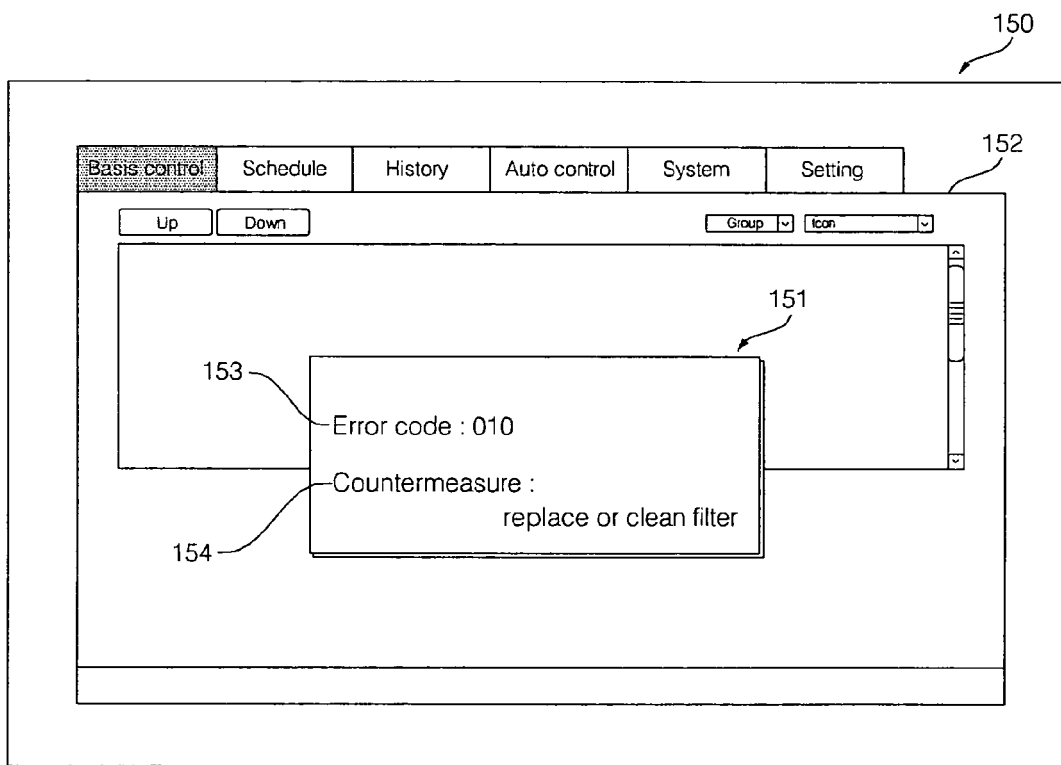

FIG. 6

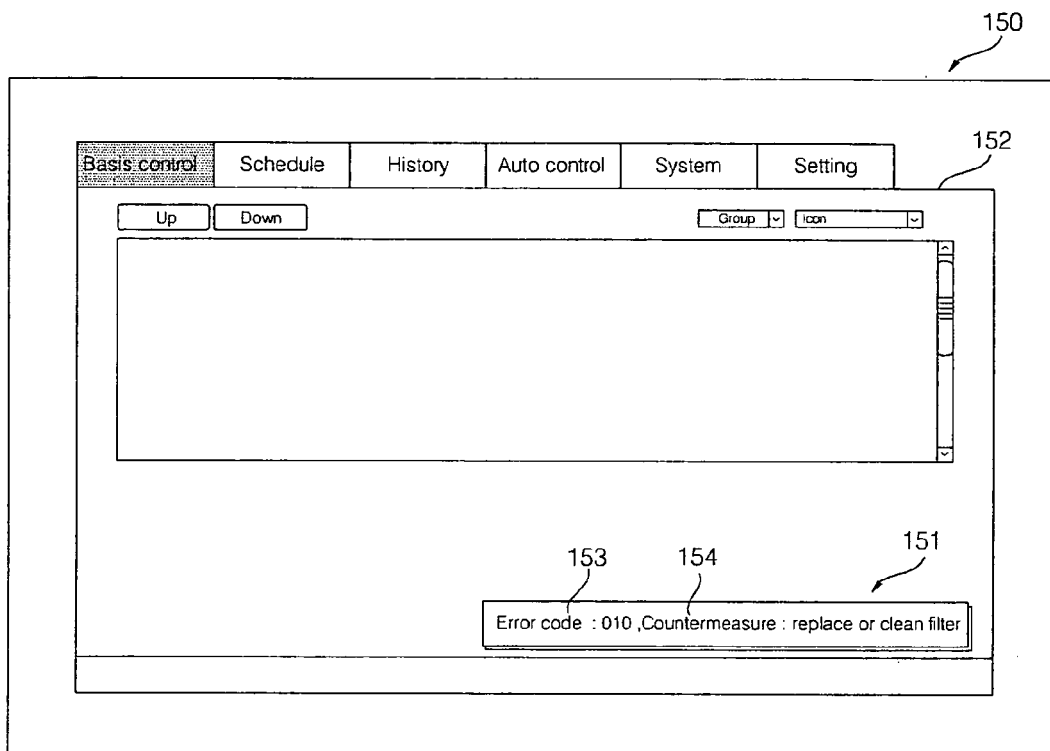

FIG. 7

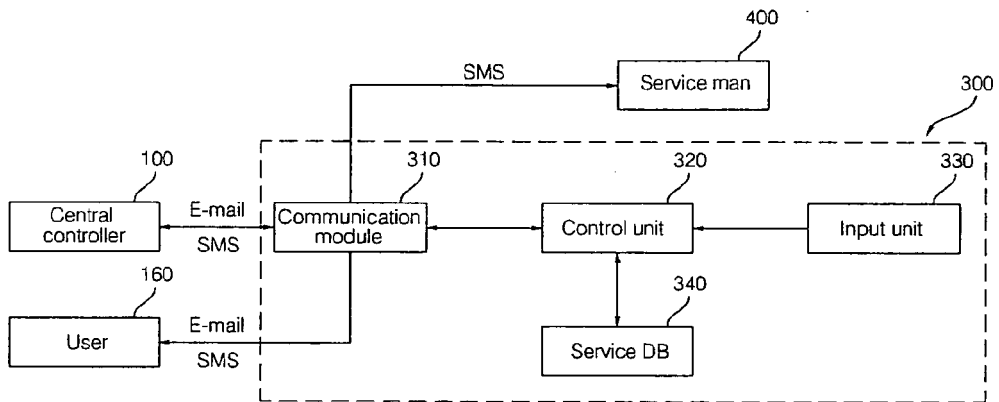

FIG. 8

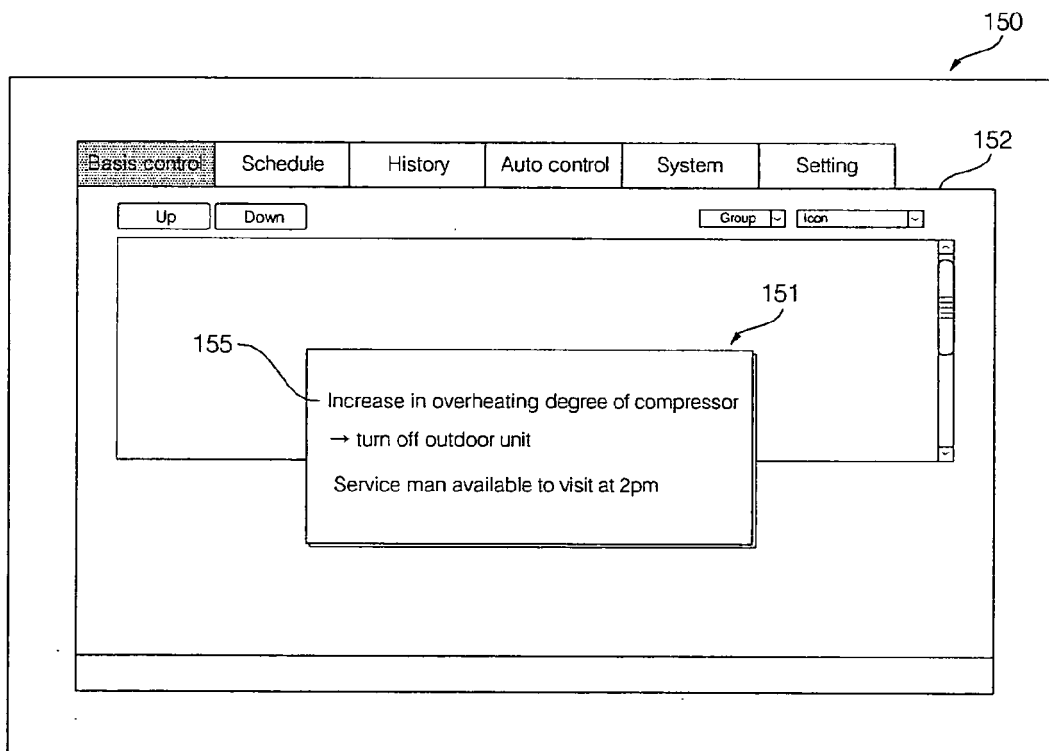
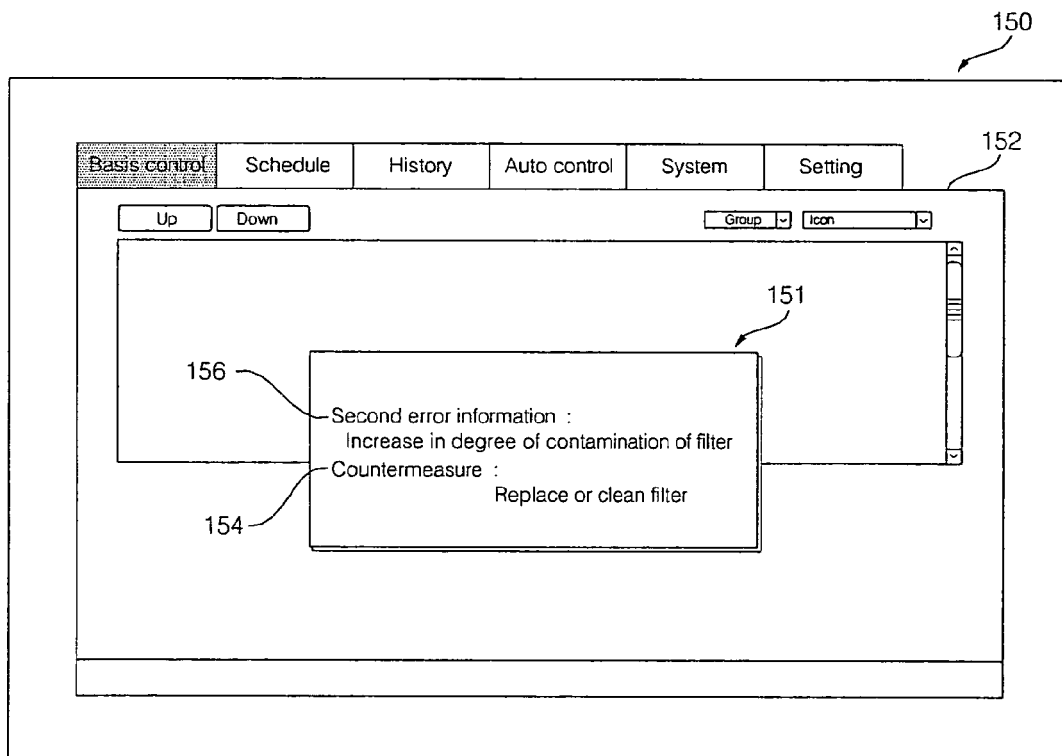

FIG. 9





EUROPEAN SEARCH REPORT

Application Number
EP 08 25 1876

| DOCUMENTS CONSIDERED TO BE RELEVANT | | | | |
|--------------------------------------------------------------------------------------------------------------------------------------------------------------------------------------------------------------------------------------------------------|---------------------------------------------------------------------------------------------------------|---------------------------------------------------------------------------------------------------------------------------------------------------------------------------------------------------------------------------------------------------------------------------------------|-----------------------------------------|---------------------------------|
| Category | Citation of document with indication, where appropriate, of relevant passages | Relevant to claim | CLASSIFICATION OF THE APPLICATION (IPC) | |
| X | US 6 643 611 B1 (ITO MAKOTO [JP] ET AL) 4 November 2003 (2003-11-04) * the whole document * | 1-13 | INV. F24F11/00 | |
| X | US 2002/154057 A1 (UEDA HIROYUKI [JP] ET AL) 24 October 2002 (2002-10-24) * the whole document * | 1-13 | | |
| X | US 2002/029096 A1 (TAKAI TADASHI [JP] ET AL) 7 March 2002 (2002-03-07) * the whole document * | 1-13 | | |
| X | US 6 385 510 B1 (HOOG KLAUS D [US] ET AL) 7 May 2002 (2002-05-07) * the whole document * | 1 | | |
| X | JP 11 344249 A (SANYO ELECTRIC CO) 14 December 1999 (1999-12-14) * abstract * | 1 | | |
| X | EP 1 335 166 A (MITSUBISHI ELECTRIC CORP [JP]) 13 August 2003 (2003-08-13) * the whole document * | 1-13 | | TECHNICAL FIELDS SEARCHED (IPC) |
| X | EP 1 426 703 A (LG ELECTRONICS INC [KR]) 9 June 2004 (2004-06-09) * abstract * | 1 | | F24F |
| X | EP 1 429 083 A (LG ELECTRONICS INC [KR]) 16 June 2004 (2004-06-16) * abstract * | 1 | | |
| X | EP 1 429 082 A (LG ELECTRONICS INC [KR]) 16 June 2004 (2004-06-16) * abstract * | 1 | | |
| E | EP 1 956 311 A (LG ELECTRONICS INC [KR]) 13 August 2008 (2008-08-13) * abstract * | 1 | | |
| The present search report has been drawn up for all claims | | | | |
| Place of search Munich | | Date of completion of the search 9 February 2009 | Examiner Valenza, Davide | |
| CATEGORY OF CITED DOCUMENTS X : particularly relevant if taken alone Y : particularly relevant if combined with another document of the same category A : technological background O : non-written disclosure P : intermediate document | | T : theory or principle underlying the invention E : earlier patent document, but published on, or after the filing date D : document cited in the application L : document cited for other reasons & : member of the same patent family, corresponding document | | |

2
EPO FORM 1503 03.02 (P/04C01)

ANNEX TO THE EUROPEAN SEARCH REPORT
ON EUROPEAN PATENT APPLICATION NO.

EP 08 25 1876

This annex lists the patent family members relating to the patent documents cited in the above-mentioned European search report. The members are as contained in the European Patent Office EDP file on
The European Patent Office is in no way liable for these particulars which are merely given for the purpose of information.

09-02-2009

| Patent document cited in search report | | Publication date | Patent family member(s) | Publication date |
|----------------------------------------|----|------------------|-------------------------|------------------|
| US 6643611 | B1 | 04-11-2003 | JP 3493547 B2 | 03-02-2004 |
| | | | JP 2001324200 A | 22-11-2001 |
| ----- | | | | |
| US 2002154057 | A1 | 24-10-2002 | JP 3590891 B2 | 17-11-2004 |
| | | | JP 2002317995 A | 31-10-2002 |
| | | | KR 20020082737 A | 31-10-2002 |
| | | | TW 500896 B | 01-09-2002 |
| ----- | | | | |
| US 2002029096 | A1 | 07-03-2002 | NONE | |
| ----- | | | | |
| US 6385510 | B1 | 07-05-2002 | NONE | |
| ----- | | | | |
| JP 11344249 | A | 14-12-1999 | JP 3789644 B2 | 28-06-2006 |
| ----- | | | | |
| EP 1335166 | A | 13-08-2003 | US 2006026972 A1 | 09-02-2006 |
| | | | US 2003140637 A1 | 31-07-2003 |
| ----- | | | | |
| EP 1426703 | A | 09-06-2004 | JP 2004184067 A | 02-07-2004 |
| | | | KR 20040048186 A | 07-06-2004 |
| | | | US 2004117069 A1 | 17-06-2004 |
| ----- | | | | |
| EP 1429083 | A | 16-06-2004 | CN 1506635 A | 23-06-2004 |
| | | | DE 60311400 T2 | 29-11-2007 |
| | | | JP 2004198102 A | 15-07-2004 |
| | | | US 2004204793 A1 | 14-10-2004 |
| ----- | | | | |
| EP 1429082 | A | 16-06-2004 | CN 1506634 A | 23-06-2004 |
| | | | JP 2004191037 A | 08-07-2004 |
| | | | US 2004107717 A1 | 10-06-2004 |
| ----- | | | | |
| EP 1956311 | A | 13-08-2008 | CN 101240936 A | 13-08-2008 |
| | | | KR 20080073574 A | 11-08-2008 |
| | | | US 2008186160 A1 | 07-08-2008 |
| ----- | | | | |