

F. SOLEY.
PADLOCK.

(Application filed Aug. 16, 1899.)

(No Model.)

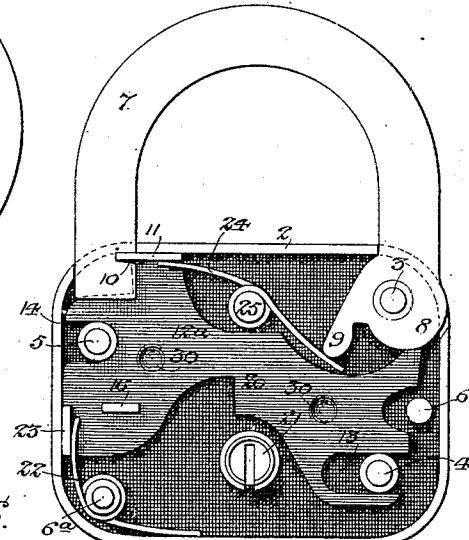
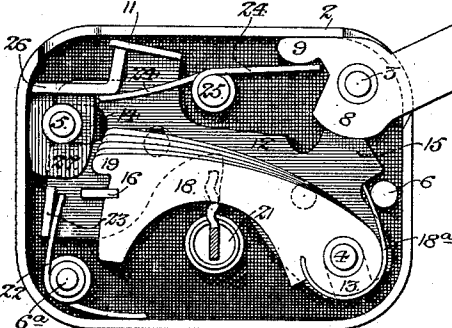
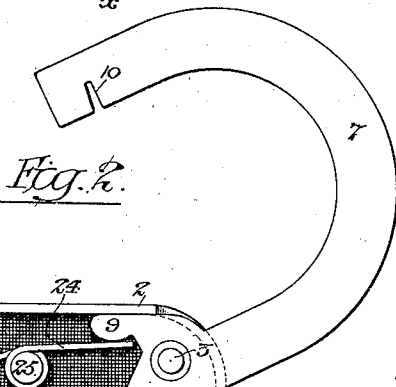
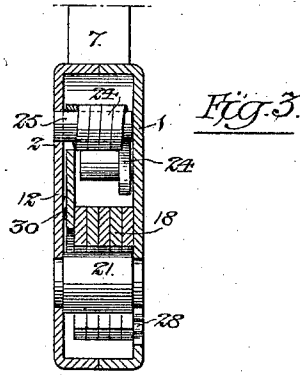
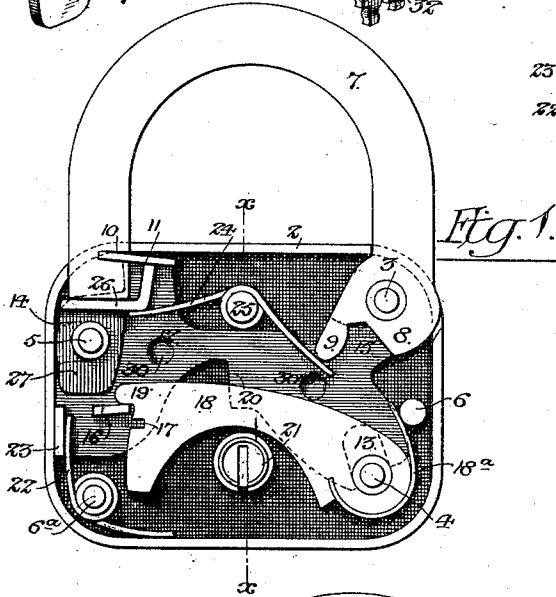
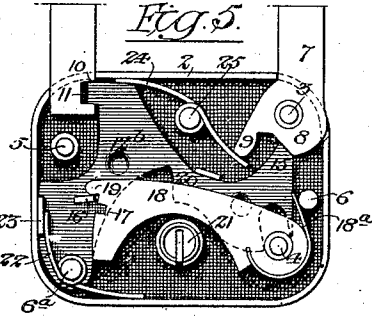
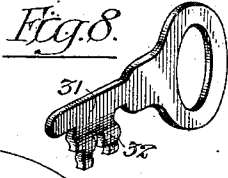
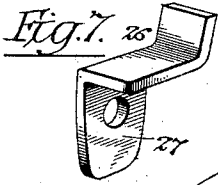

Witnesses:-
Charles W. Con.
A. W. H. Whitehead.

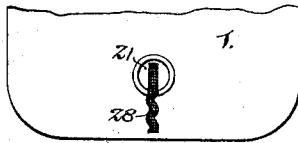

Inventor:-
Frank Soley.
By his Attorneys:
Howson & Howson

UNITED STATES PATENT OFFICE.

FRANK SOLEY, OF PHILADELPHIA, PENNSYLVANIA, ASSIGNOR TO THE MILLER LOCK COMPANY, OF PHILADELPHIA, PENNSYLVANIA, A CORPORATION OF PENNSYLVANIA.

PADLOCK.

SPECIFICATION forming part of Letters Patent No. 695,346, dated March 11, 1902.

Application filed August 16, 1899. Serial No. 727,397. (No model.)

To all whom it may concern:

Be it known that I, FRANK SOLEY, a citizen of the United States, residing in Philadelphia, Pennsylvania, have invented certain Improvements in Padlocks, of which the following is a specification.

The object of my invention is to construct a padlock possessing a high degree of security, together with extreme simplicity and cheapness of construction; and this object I attain in the manner hereinafter set forth, reference being had to the accompanying drawings, in which—

Figure 1 is a view of a padlock constructed in accordance with my invention, the face-plate of the lock being removed to show the internal construction and the parts being shown in the locked position. Fig. 2 is a view similar to Fig. 1, but showing the parts in the unlocked position. Fig. 3 is a transverse section on the line *x x*, Fig. 1. Figs. 4 and 5 are views illustrating slight modifications in the shackle-locking plate. Fig. 6 is an outside view of the lower portion of the lock. Fig. 7 is a perspective view of one of the elements of the lock, and Fig. 8 is a perspective view of the key. Figs. 5, 6, and 8 are on a smaller scale than the other figures of the drawings.

The casing of the lock is composed of front and back plates 1 and 2, preferably struck up from sheet metal and dished, as shown in Fig. 3, so as to form a casing for the reception of the working parts of the lock, the front and back plates of the lock being preferably secured together by riveting the ends of transverse studs or posts 3, 4, 5, and 6^a, which are suitably shouldered, so as to provide bearings for the opposite face-plates of the lock.

In the lock shown in Figs. 1, 2, and 3 the stud 3 serves as a pivot for the shackle 7, which has adjacent to said pivot a projecting heel 8 and a finger 9, the free end of the shackle having a notch or recess 10 for the reception of a bolt 11 upon a locking-plate 12, which has slots 13 and 14, whereby it is suitably guided upon the studs or posts 4 and 5 of the lock-casing, said locking-plate also having a tail 15, which engages with the heel 8 of the shackle, and a lug or stump 16 for en-

tering the notches 17 of the tumblers 18 when said notches have been brought into line. The tumblers are pivoted to the stud 4, each tumbler being acted upon by a spring 18^a, bearing upon the stud 6 and tending to depress the free end of the tumbler to an extent permitted by contact of the stop-lug 19 thereon with the stump 16.

The locking-plate 12 has a shoulder 20, adapted to be acted upon by a key inserted in the rotatable key-hub 21, so that the said plate can be moved in order to withdraw its bolt 11 from the notch of the shackle, the same movement causing the stump 16 to enter the notches 17 of the tumblers 18, which have been previously moved by the key, so as to bring their notches into line with said stump. A spring 22 is coiled around the stud 6^a, one end of this spring acting upon a lug or projection 23 on the locking-plate 12 in order to move the latter in a direction opposite to that in which it is moved by the key, the other end of said spring bearing upon the lock-casing. Another spring 24 is coiled around a stud 25, one end of this spring acting upon the finger 9 of the shackle, so as to cause said shackle to swing open as soon as it is released from the retaining influence of the bolt 11 and tail 15 of the locking-plate. (See Fig. 2.) The other end of the spring 24 bears upon an L-shaped stop-flange 26, which is formed upon a plate 27, mounted upon the stud 5, the form of this stop-flange being more clearly shown in Fig. 7. The flange extends across the interior of the lock from the casing 1 to the plate 12 and serves in connection with said plate and the lock-casing to completely inclose the space into which the notched end of the shackle is intended to project. Hence it prevents access of dirt or other foreign matters to the interior of the lock-casing and also any tampering with the tumblers of the lock when the shackle is open.

The guide-slot 13 of the locking-plate and that face of the tail 15 of said plate which engages with the heel 8 of the shackle are angularly disposed in respect to the locking-bolt 11, guide-slot 14, and stump 16 of the

locking-plate—that is to say, while the latter travel in substantially horizontal lines on the opening movement of the locking-plate the engaging face of the tail 15 and the slotted lower portion of the locking-plate travel rearwardly and downwardly. By reason of this construction the engaging face of the tail 15 of the locking-plate when in locking position is substantially at right angles to the line of movement which the heel 8 of the shackle must follow in the opening movement of said shackle. Consequently said tail 15 opposes an effective resistance to such opening movement and will serve to prevent the opening of the shackle even if the bolt 11 and notch 10 are not operative to effect such result.

When the lock is closed, the lug 23 of the locking-plate bears against the casing of the lock, as shown in Fig. 1, and hence precludes any attempt to open the lock by jarring the same, so as to cause the locking-plate to swing upon the stump 16 as a fulcrum, for such movement would necessitate an outward movement of the lug 23, and this is impossible because of the bearing of said lug upon the casing of the lock.

The combined sliding and swinging movement of the locking-plate 12 is always to be preferred, although it may be departed from without sacrificing the other valuable features of my invention—that is to say, the simplicity and economy of the lock when compared with the high degree of security afforded by it. These are due to the fact that the lock has but one part—namely, the locking-plate 12—in addition to the parts which are essential to any padlock of this character—that is to say, the casing, the shackle, the spring or springs, the tumblers, and the key-hub. Hence, owing to this simplicity in construction, I can without unduly increasing the expense of the lock use therein a considerable number of tumblers, and thus gain the security which such considerable number of tumblers affords.

As an instance of a lock embodying some of the features of my invention, but having a parallel moving locking-plate 12^a instead of a plate which has a combined sliding and swinging movement, I may refer to the modification shown in Fig. 4, the operation of which will be readily understood without detailed explanation.

In Fig. 5 I have shown a further modification, in which the locking-plate 12^b has a swinging movement only, being hung to the stud 6^a, but having the beveled and diagonally-moving locking-tail 15 for engaging with the heel 8 of the shackle when the lock is closed.

In Figs. 4 and 5 I have omitted to show the flange 26 and plate 27 in order to more clearly illustrate the locking-plate.

For additional security the keyhole 28, formed in the face-plate 1 of the lock-casing,

is corrugated, as shown in Fig. 6, and a similar form is given to the bitted portion of the key, as shown in Figs. 2 and 8, the key having a flat stem or shank 31 for engagement with the key-hub 21, and a side-bitted and longitudinally-corrugated portion 32, projecting laterally from said stem, as shown in Fig. 8.

In order to lessen the friction due to the sliding movement of the locking-plate, the latter has by preference struck up from it studs 30, which bear upon the back plate of the lock-casing and prevent contact of the locking-plate therewith.

Having thus described my invention, I claim and desire to secure by Letters Patent—

1. A padlock in which are combined a casing, a pivoted shackle having a projecting heel, a series of notched tumblers, and a guided locking-plate adapted to be actuated by the key and having a bolt for engaging with a notch in the shackle, a stump for engaging with the notches in the tumblers, a tail for engaging with the heel of the shackle, and a lug bearing against the casing of the lock when the locking-plate is in its retaining position, substantially as specified.

2. The combination, in a padlock, of the casing, a pivoted shackle having a projecting heel, a series of notched tumblers, and a locking-plate adapted to be actuated by the key, said locking-plate having slots for the reception of guide studs or posts in the lock, a bolt for engaging with the notch in the shackle, a stump for engaging with the notches of the tumblers, and a tail for engaging with the heel of the shackle, the engaging face of said tail and the rear guide-slot of the locking-plate being angularly disposed in respect to the locking-bolt, forward guide-slot and stump, whereby the movement of the locking-plate is a combined sliding and swinging movement, substantially as specified.

3. The combination, in a padlock, of the casing, the pivoted shackle having a projecting heel, a series of notched tumblers, and a locking-plate having slots for the reception of guide studs or posts in the lock, a locking-bolt for engaging a notch of the shackle, a stump for entering the notches of the tumblers, a tail for engaging with the heel of the shackle, and a lug bearing against the casing of the lock when the latter is closed, the rear guide-slot of the locking-plate and the engaging face of the tail of said plate being angularly disposed in respect to the locking-bolt, forward guide-slot and stump, substantially as specified.

4. The combination in a padlock, of the casing, the shackle, locking devices for the latter, and an angular flange for closing at the bottom and inner side the space within the lock into which the nose of the shackle enters, substantially as specified.

5. The combination in a padlock, of the cas-

ing, the shackle, locking devices for the latter,
and a plate mounted within the lock-casing
and having an angular flange for closing at the
bottom and inner side the space within the
5 lock into which the nose of the shackle enters,
substantially as specified.

In testimony whereof I have signed my

name to this specification in the presence of
two subscribing witnesses.

FRANK SOLEY.

Witnesses:

ALLAN J. CASSIDY,
CHARLES E. LEVER.