

[54] COMBINED DESK TOP AND MOVABLE CRT SUPPORT UNIT

[75] Inventors: William R. Worrell, Hopkins, Minn.; Robert N. Laroche, Montreal, Canada

[73] Assignee: All-Steel Canada Ltd., Quebec, Canada

[\*] Notice: The portion of the term of this patent subsequent to May 26, 2001 has been disclaimed.

[\*\*] Term: 14 Years

[21] Appl. No.: 741,173

[22] Filed: Jun. 4, 1985

Related U.S. Application Data

[63] Continuation-in-part of Ser. No. 670,036, Nov. 13, 1984.

[52] U.S. CL ..... D6/509; D6/422; D6/511

[58] Field of Search ..... D6/422-428, D6/480, 484, 491, 509, 511; 108/27

[56] References Cited

U.S. PATENT DOCUMENTS

- D. 281,299 11/1985 Esslinger ..... D6/491
D. 283,094 3/1986 Strand et al. .... D6/484 X
D. 284,532 7/1986 Vogt ..... D6/480 X
D. 289,954 5/1987 Worrell et al. .... D6/511

FOREIGN PATENT DOCUMENTS

3132015 10/1982 Fed. Rep. of Germany ..... 108/27

Primary Examiner—Bruce W. Dunkins

Attorney, Agent, or Firm—Mann, McWilliams, Zummer & Sweeney

[57] CLAIM

The ornamental design for a combined desk top and movable CRT support unit, substantially as shown and described.

DESCRIPTION

FIG. 1 is a diagrammatic perspective view, taken from the front side (the side where the worker sits) and left hand end of the desk top, and from above same, showing our new design, with the CRT support carriage in one specific position of adjustment laterally of the desk top;

FIG. 2 is a diagrammatic perspective view of same, taken from the front and right hand end of the desk top, and above same, showing our new design;

FIG. 3 is a diagrammatic perspective view of same taken from the rear or back side and right hand end of the desk top, showing the CRT support carriage in the same position relative to the desk top as shown in FIGS. 1 and 2;

FIG. 4 is a diagrammatic perspective view of same, and taken from the rear and left hand end of the desk top;

FIG. 5 is a bottom plan view of the same, with the CRT support carriage shown in the position of FIGS. 1-4;

FIG. 6 is a front elevational view of same;

FIG. 7 is a rear elevational view of same;

FIG. 8 is a top plan view of same with the CRT support carriage shown in the position of FIGS. 1-7.

FIG. 9 is a top plan view of same, with the CRT carriage shown in an alternate forwardly extended position; and

FIG. 10 is a top plan view of same, with the CRT carriage shown in an alternate position spaced longitudinally of the desk top, and to the left of the CRT support carriage position shown in FIG. 9, indicating another position of adjustment of the CRT support carriage.

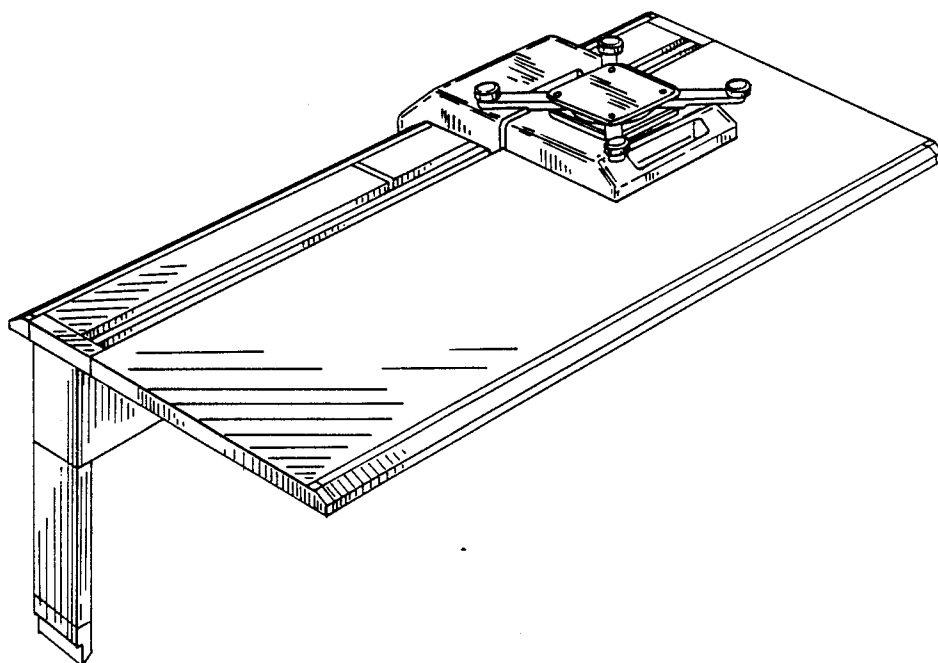

FIG. 1

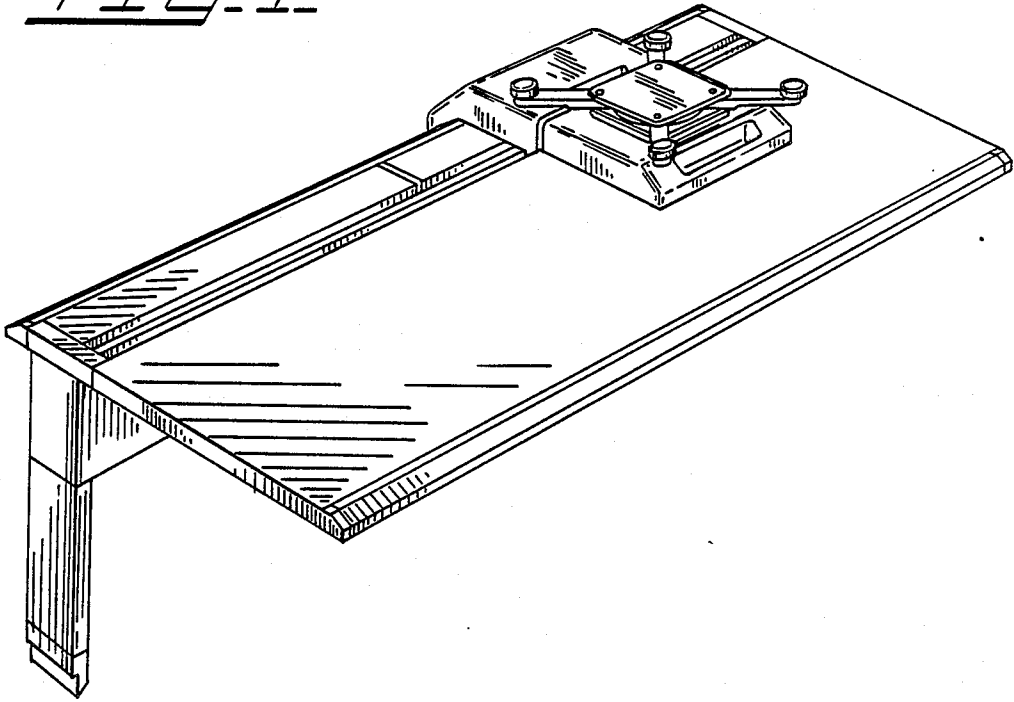

FIG. 2

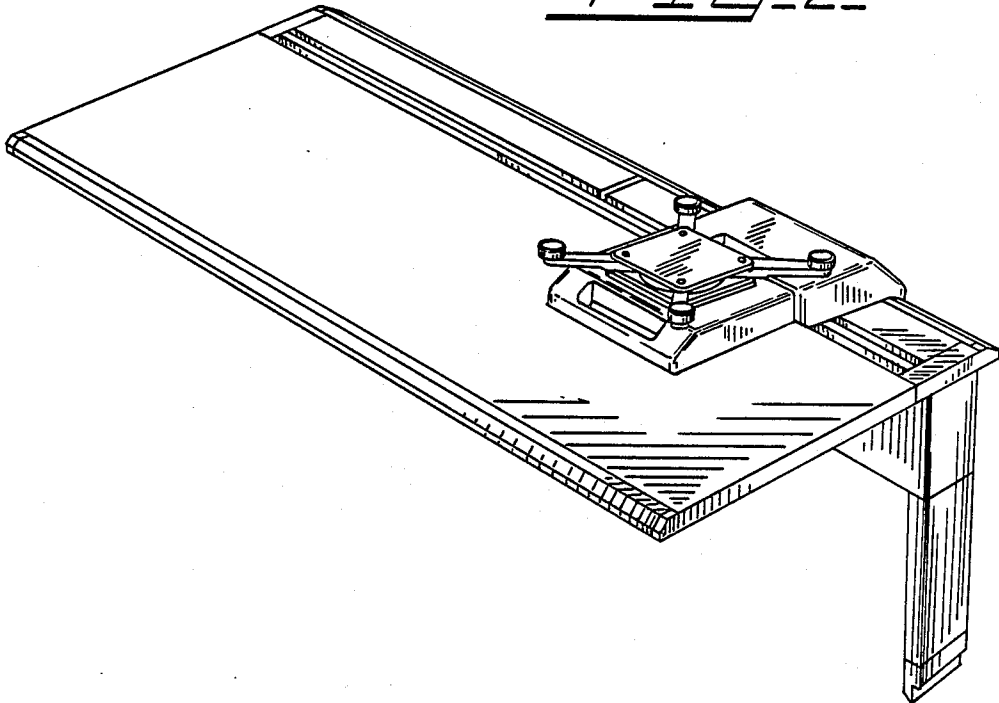

FIG. 3.

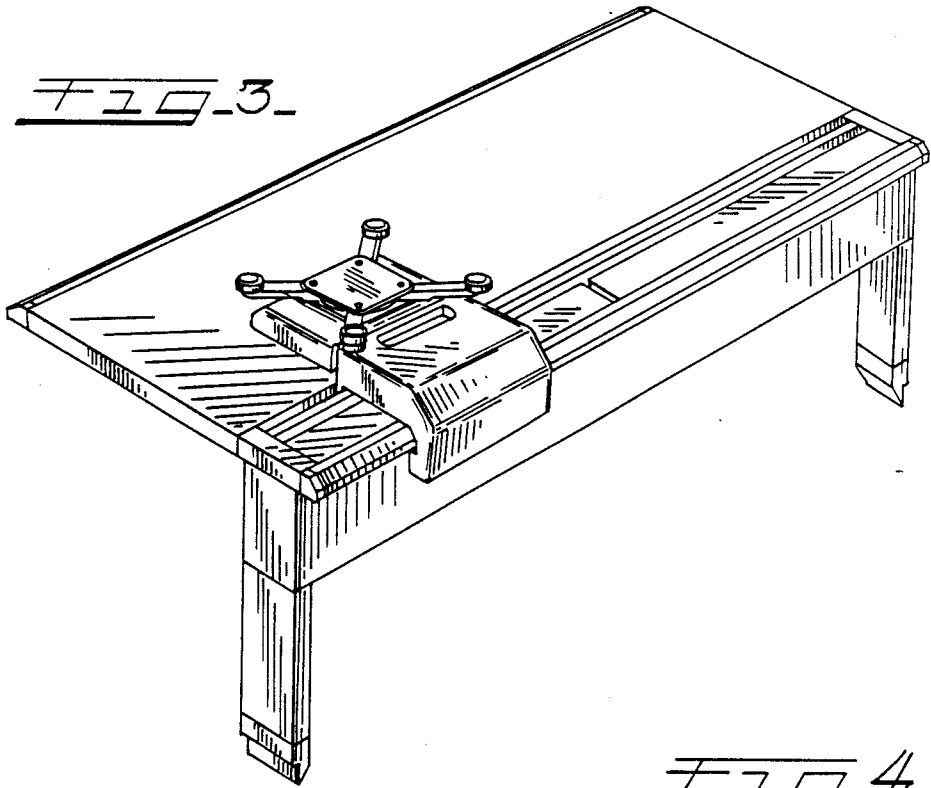

FIG. 4.

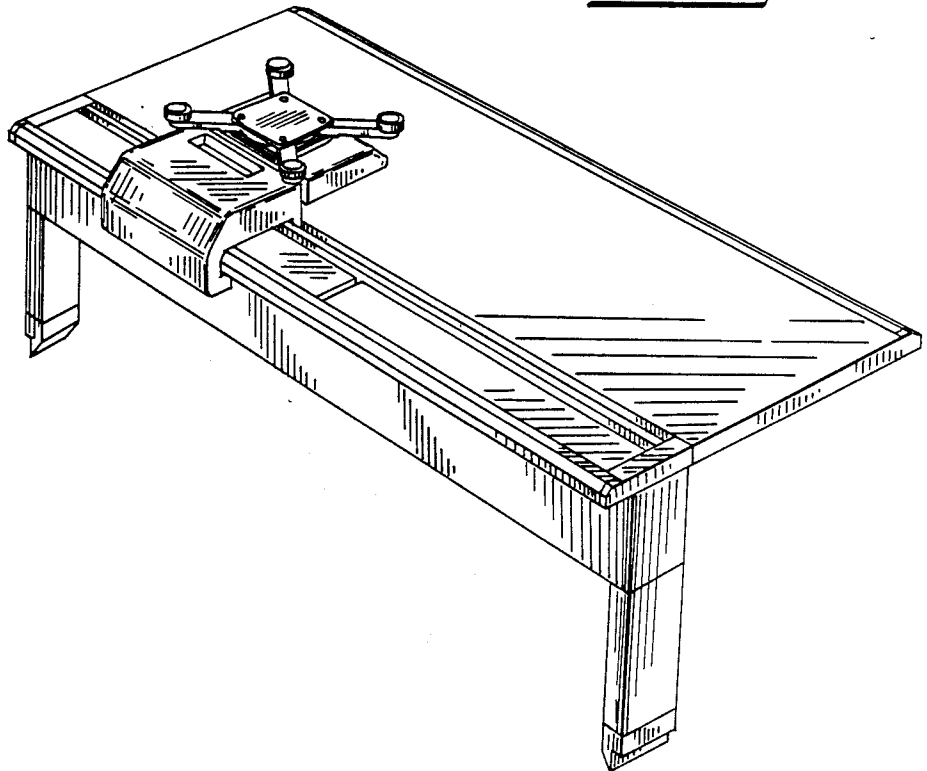

FIG. 5.

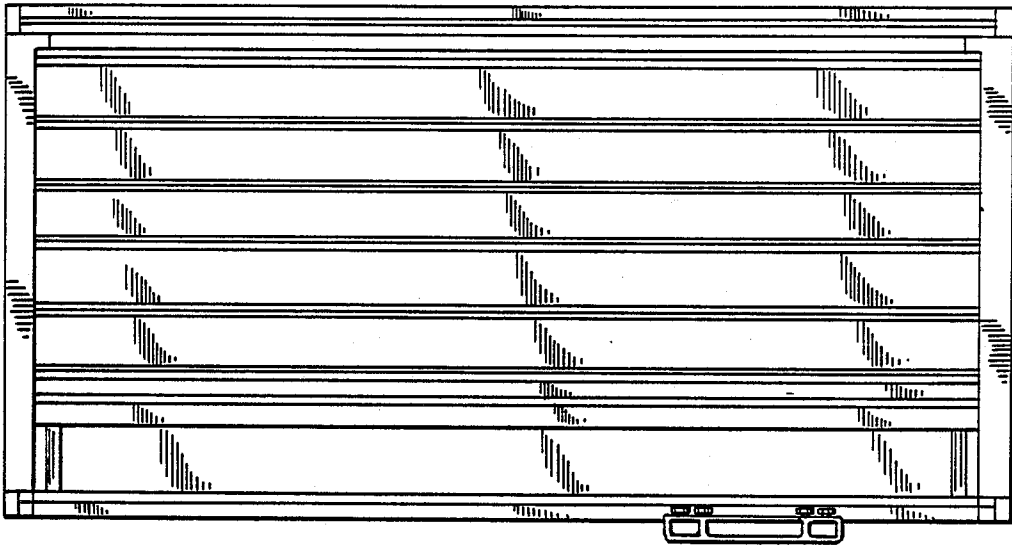

FIG. 6.

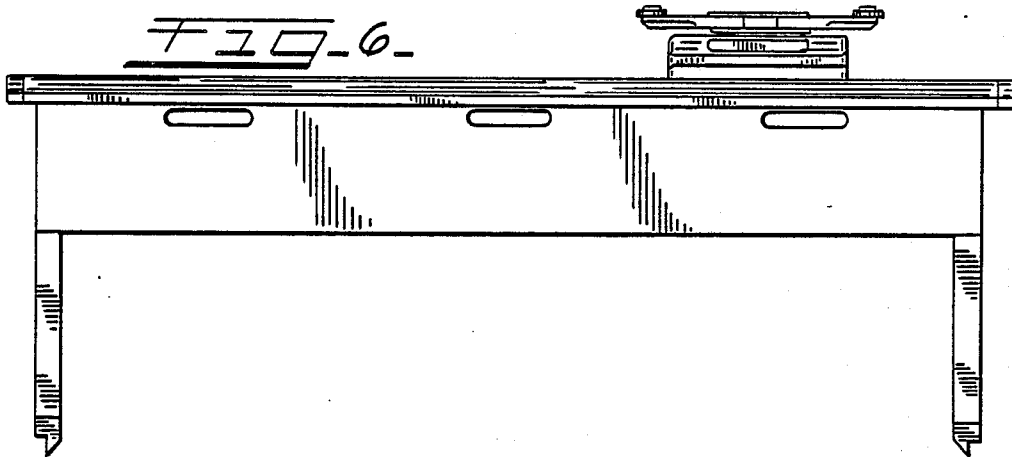
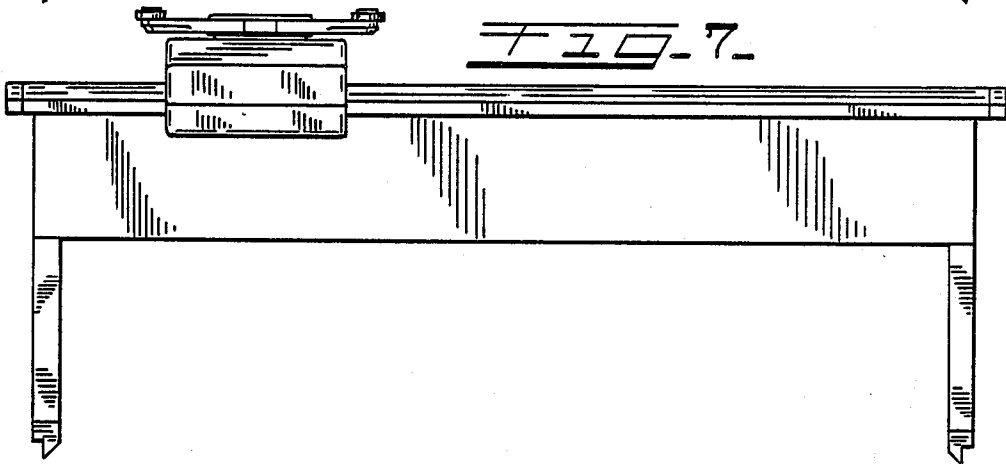

FIG. 7.



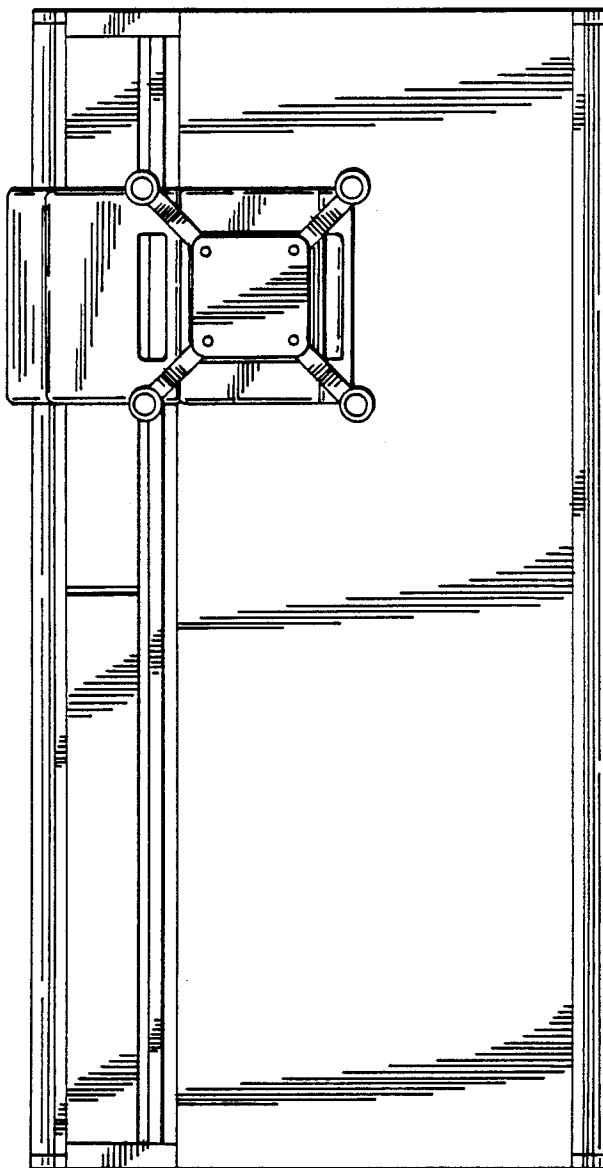

FIG-8-

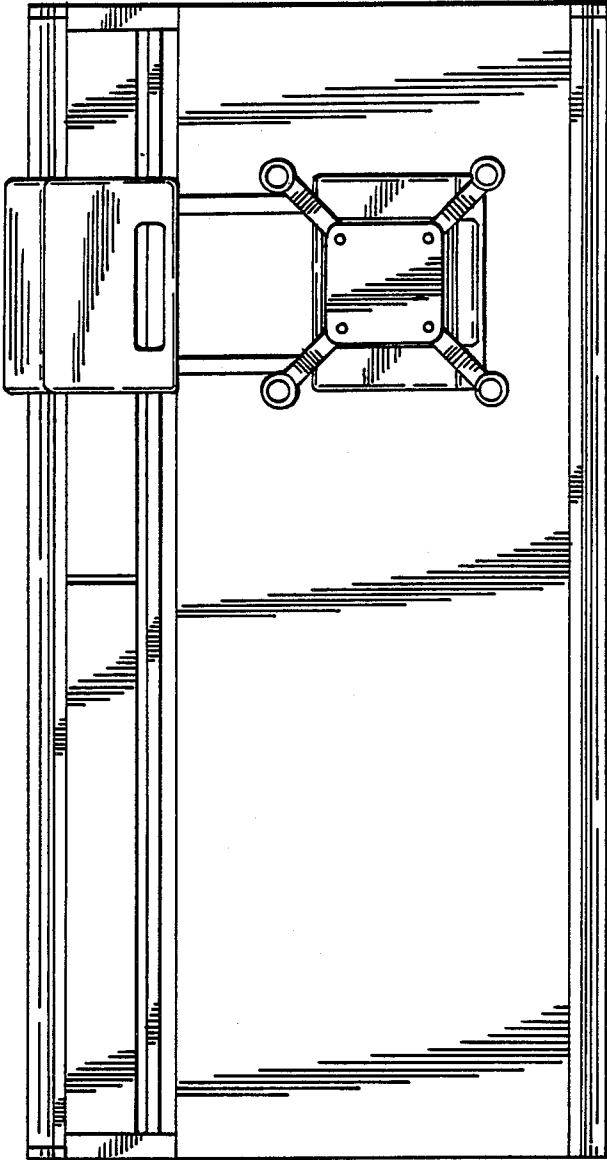

FIG. 9-

FIG. 10.

